



energy  
**[r]evolution**

A SUSTAINABLE WORLD ENERGY OUTLOOK 2015

100% RENEWABLE ENERGY FOR ALL



**GWEC**  
GLOBAL WIND ENERGY COUNCIL

 SolarPower  
Europe

**GREENPEACE**

# foreword

---



## authors & reviewers

Greenpeace International,  
Global Wind Energy Council  
SolarPowerEurope

Date September 2015  
ISBN

### Project manager and lead author

Dr. Sven Teske,  
Greenpeace International  
Global Wind Energy Council  
Steve Sawyer  
SolarPowerEurope  
Oliver Schäfer

### Research & co-authors

Overall Modelling: DLR, Institute of Engineering Thermodynamics, Systems Analysis and Technology Assessment, Stuttgart, Germany; Dr. Thomas Pregger, Dr. Sonja Simon, Dr. Tobias Naegler

**image** SOLON AG PHOTOVOLTAICS FACILITY IN ARNSTEIN OPERATES 1,500 HORIZONTAL AND VERTICAL SOLAR "MOVERS". IT IS THE LARGEST TRACKING SOLAR FACILITY IN THE WORLD, AND DELIVERS 12 MEGAWATT OF ENERGY. EACH "MOVER" CAN BE BOUGHT FROM S.A.G. SOLARSTROM AG AS A PRIVATE INVESTMENT.



© PAUL LAUER/ROCKHORN/PEACE

**Transport:** DLR, Institute of Vehicle Concepts, Stuttgart, Germany; Dr. Stephan Schmid, Dr. Doruk Özdemir, Johannes Pagenkopf, Florian Kleiner

**Employment:** Institute for Sustainable Futures, University of Technology, Sydney; Jay Rutovitz, Elsa Dominish, Jenni Downes (Chapter 6/7)

**Grid and rural electrification technology:** energynautics GmbH, Langen/Germany; Dr. Thomas Ackermann, Dr. Tom Brown (Chapter 10)

**Contributing authors:** Simon Boxer; GP New Zealand (Chapter 10), Dr. Ricardo Baitelo & Larissa A. Rodrigues Greenpeace Brazil (Chapter 6)

**Editor:** Craig Morris, Petite Planète  
[www.petiteplanete.org](http://www.petiteplanete.org)

**Design & Layout:** Tania Dunster, Jens Christiansen, onehemisphere, Sweden  
[www.onehemisphere.se](http://www.onehemisphere.se)

**Contact:** [info@greenpeace.de](mailto:info@greenpeace.de)  
[info@gwec.net](mailto:info@gwec.net)

This research has been co-financed by: Umweltstiftung / Greenpeace, Hongkong Strasse 10, 20457 Hamburg, Germany, Melanie Stöhr [umweltstiftung-greenpeace.de](http://umweltstiftung-greenpeace.de)

# foreword



The Energy [R]evolution project marks its first decade of ambitious (renewable) energy scenarios for countries and regions. The E[R] is now a well-known and respected projection for future renewable energy markets; it is widely seen as an alternative view to the IEA's World Energy Outlook.

REN21's Renewables Global Status Report has become over the past decade the most frequently referenced report on renewable energy market, industry and policy trends. Similarly, the Energy [R]evolution has provided regular projections for the current and future renewable energy markets. Each edition (five to date including this one) triggers important debates within the energy sector.

## contents at a glance

FOREWORD	2	<b>CHAPTER 2</b>	<b>CHAPTER 4</b>
INTRODUCTION	8	CLIMATE AND ENERGY POLICY	FINANCING THE ENERGY [R]EVOLUTION
EXECUTIVE SUMMARY	10	<b>CHAPTER 3</b>	
<b>CHAPTER 1</b>		THE ENERGY [R]EVOLUTION CONCEPT	
CLIMATE CHANGE AND NUCLEAR THREATS	17		<b>CHAPTER 5</b>
			SCENARIO FOR A FUTURE ENERGY SUPPLY
			48
			58

**image** NORTHBOUND AND SOUTHBOUND SHIPPING LANES OFF THE COAST OF CHINA'S SHANDONG PENINSULA. THE LANES FORM ONE OF THE MAIN ROUTES FROM THE YELLOW SEA INTO THE BOHAI SEA AND THE CHINESE PORTS OF DALIAN AND TIANJIN, TWO OF THE BUSIEST IN THE WORLD. THE VESSELS IN THIS IMAGE ARE MOST LIKELY CARGO SHIPS, THEIR PROPELLERS KICK UP LONG, BROWN SEDIMENT PLUMES.

Renewable energy continued to grow in 2014 in parallel with global energy consumption and falling oil prices. Despite rising energy use, for the first time in 40 years, global CO<sub>2</sub> emissions associated with energy consumption remained stable over the course of the year while the global economy grew. The landmark “decoupling” of economic and CO<sub>2</sub> growth is due in large measure to China’s increased use of renewable resources, and efforts by countries in the OECD to promote renewable energy and energy efficiency. This is particularly encouraging in view of COP21 later this year in Paris, where countries will announce and/or confirm actions to mitigate climate change, setting the stage for future investment in renewables and energy efficiency.

This decoupling clearly signals that renewables have become a mainstream energy resource. The penetration and use of both variable and non-variable renewables are increasing, thereby contributing to diversification of the energy mix. As of early 2015, 164 countries have renewable energy targets in place. Many of these countries have also engaged in an energy transition path towards renewable energy and energy efficiency.

However, even with these successes, growth in renewables capacity as well as improvements in energy efficiency are below the rates necessary to achieve the Sustainable Energy for All (SE4All) goals of: doubling the level of renewable energy; doubling the global rate of improvement in energy efficiency; and providing universal energy access by 2030.

We are still not on the pathway to 100% renewable energy globally; a lot remains to be done particularly to increase the use of renewables in the heating and transport sectors. This latest edition of the Energy [R]evolution provides insight of what needs to be done and where renewable energy markets need to go. REN21 welcomes the new Energy [R]evolution scenario as an important contribution to the global energy policy debate. It provides guidance on where investments need to reduce CO<sub>2</sub> emissions below the carbon budget climate scientist have identified to avoid runaway climate change.

The past decade has set the wheels in motion for a global energy transition with renewables; it is accelerating in many parts of the world. With the implementation of ambitious targets and innovative policies, renewables can continue to surpass expectations and create a clean, equitable energy future.

**Christine Lins**

EXECUTIVE SECRETARY, REN21

SEPTEMBER 2015

<b>CHAPTER 6</b>		<b>CHAPTER 8</b>		<b>CHAPTER 10</b>		<b>CHAPTER 12</b>	
SCENARIO RESULTS	82	THE SILENT ENERGY		ENERGY TECHNOLOGIES	226	TRANSPORT	286
		MARKET [R]EVOLUTION	204				
<b>CHAPTER 7</b>		<b>CHAPTER 9</b>		<b>CHAPTER 11</b>		<b>CHAPTER 13</b>	
EMPLOYMENT PROJECTIONS -		ENERGY RESOURCES AND		ENERGY EFFICIENCY –		GLOSSARY, REFERENCES	
METHODOLOGY AND		SECURITY OF SUPPLY	214	MORE WITH LESS	270	& APPENDIX	307
ASSUMPTIONS	194						

# TABLE OF CONTENTS

<b>FOREWORD</b>	<b>2</b>	<b>5.2 SCENARIO APPROACH AND BACKGROUND STUDIES</b>	<b>61</b>
<b>INTRODUCTION</b>	<b>8</b>	<b>5.3 SCENARIO REGIONS</b>	<b>62</b>
<b>EXECUTIVE SUMMARY</b>	<b>10</b>	<b>5.4 MAIN SCENARIO ASSUMPTIONS</b>	<b>64</b>
		5.4.1 POPULATION DEVELOPMENT	64
		5.4.2 ECONOMIC GROWTH	65
		5.4.3 OIL AND GAS PRICE PROJECTION	66
		5.4.4 COST PROJECTIONS FOR EFFICIENT FOSSIL FUEL GENERATION AND CARBON CAPTURE AND STORAGE (CCS) AND CO <sub>2</sub> EMISSIONS	67
		5.4.5 COST PROJECTIONS FOR RENEWABLE ENERGY TECHNOLOGIES	67
		5.4.6 COST PROJECTIONS FOR RENEWABLE HEATING TECHNOLOGIES	72
		5.4.7 ASSUMPTIONS FOR HYDROGEN AND SYN FUEL PRODUCTION FROM RENEWABLE ELECTRICITY	73
		5.4.8 ASSUMED GROWTH RATES IN SCENARIO DEVELOPMENT	74
		5.4.9 ASSUMPTIONS FOR FOSSIL FUEL PHASE OUT	75
		<b>5.5 REVIEW: GREENPEACE SCENARIO PROJECTIONS OF THE PAST</b>	<b>76</b>
		5.5.1 THE DEVELOPMENT OF THE GLOBAL WIND INDUSTRY	76
		5.5.2 THE DEVELOPMENT OF THE GLOBAL SOLAR PHOTOVOLTAIC INDUSTRY	79
		<b>5.6 HOW DOES THE ENERGY [R]EVOLUTION SCENARIO COMPARE TO OTHER SCENARIOS?</b>	<b>80</b>
<b>CHAPTER 1: CLIMATE CHANGE AND NUCLEAR THREATS</b>	<b>17</b>		
1.1 THE IMPACTS OF CLIMATE CHANGE	18		
1.2 CLIMATE CHANGE – THE SCIENCE	19		
1.2.1 OBSERVED CHANGES	19		
1.2.2 CAUSES OF CLIMATE CHANGE	20		
1.2.3 IMPACTS OF CLIMATE CHANGE	20		
1.2.4 EXTREME EVENTS	22		
1.3 NUCLEAR THREATS	22		
1.3.1 NO SOLUTION TO CLIMATE PROTECTION	23		
1.3.2 THE DANGERS OF NUCLEAR POWER	23		
<b>CHAPTER 2: CLIMATE AND ENERGY POLICY</b>	<b>25</b>		
2.1 INTERNATIONAL CLIMATE POLICY - THE UNFCCC AND THE KYOTO PROTOCOL	26		
2.1.1 INTERNATIONAL ENERGY POLICY - ENERGY POLICY AND MARKET REGULATION	27		
2.2 RENEWABLE ENERGY POLICIES	27		
2.2.1 STATUS OF RENEWABLE ENERGY POLICIES FOR ELECTRICITY	28		
2.2.2 STATUS OF RENEWABLE ENERGY POLICIES FOR HEATING AND COOLING	28		
2.2.3 RENEWABLE ENERGY TRANSPORT POLICIES	28		
2.2.4 CITY AND LOCAL GOVERNMENT RENEWABLE ENERGY POLICIES	28		
2.2.5 DISTRIBUTED RENEWABLE ENERGY IN DEVELOPING COUNTRIES	29		
2.2.6 ENERGY EFFICIENCY: RENEWABLE ENERGY'S TWIN PILLAR	29		
2.3 POLICY RECOMMENDATIONS	30		
<b>CHAPTER 3: THE ENERGY [R]EVOLUTION CONCEPT</b>	<b>35</b>		
3.1 STATUS QUO OF THE GLOBAL ENERGY SECTOR	36		
3.2 SETTING UP AN ENERGY [R]EVOLUTION SCENARIO	37		
3.3 THE ENERGY [R]EVOLUTION LOGIC	37		
3.4 THE "5 STEP IMPLEMENTATION"	39		
<b>CHAPTER 4: FINANCING THE ENERGY [R]EVOLUTION</b>	<b>48</b>		
4.1 RENEWABLE ENERGY PROJECT PLANNING BASICS	49		
4.2 THE IMPACTS OF CLIMATE CHANGE	50		
4.3 OVERCOMING BARRIERS TO FINANCE AND INVESTMENT FOR RENEWABLE ENERGY	52		
4.4 HOW TO OVERCOME INVESTMENT BARRIERS FOR RENEWABLE ENERGY	54		
4.5 THE FIRST DECADE OF RENEWABLE ENERGY FINANCING	54		
4.5.1 INVESTMENT BY ECONOMIC GROUP (REN21 – 2015)	55		
4.5.2 FINANCING MODELS	56		
4.5.3 INVESTMENT SOURCES AS OF 2014	57		
<b>CHAPTER 5: SCENARIO FOR A FUTURE ENERGY SUPPLY</b>	<b>58</b>		
5.1 SCENARIO STORYLINES AND MAIN PREMISES	59		
		<b>CHAPTER 6: SCENARIO RESULTS</b>	<b>82</b>
		6.1 GLOBAL SCENARIO RESULTS	83
		6.1.1 GLOBAL: PROJECTION OF ENERGY INTENSITY	83
		6.1.2 FINAL ENERGY DEMAND BY SECTOR	84
		6.1.2 ELECTRICITY GENERATION	86
		6.1.3 FUTURE COSTS OF ELECTRICITY GENERATION	87
		6.1.4 FUTURE INVESTMENTS IN THE POWER SECTOR	87
		6.1.5 ENERGY SUPPLY FOR HEATING	88
		6.1.6 FUTURE INVESTMENTS IN THE HEATING SECTOR	89
		6.1.7 FUTURE EMPLOYMENT IN THE ENERGY SECTOR	89
		6.1.8 TRANSPORT	91
		6.1.9 DEVELOPMENT OF CO <sub>2</sub> EMISSIONS	92
		6.1.10 PRIMARY ENERGY CONSUMPTION	92
		6.2 OECD NORTH AMERICA	94
		6.3 LATIN AMERICA	104
		6.4 OECD EUROPE	114
		6.5 AFRICA	124
		6.6 MIDDLE EAST	134
		6.7 EASTERN EUROPE/EURASIA	144
		6.8 INDIA	154
		6.9 OTHER ASIA	164
		6.10 CHINA	174
		6.11 OECD ASIA OCEANIA	184
		<b>CHAPTER 7: EMPLOYMENT PROJECTIONS - METHODOLOGY AND ASSUMPTIONS</b>	<b>194</b>
		7.1 EMPLOYMENT FACTORS	196
		7.2 REGIONAL ADJUSTMENTS	197
		7.2.1 REGIONAL JOB MULTIPLIERS	197
		7.2.2 LOCAL EMPLOYMENT FACTORS	197
		7.3 EMPLOYMENT RESULTS BY TECHNOLOGY	199
		7.3.1 EMPLOYMENT IN FOSSIL FUELS AND NUCLEAR TECHNOLOGY	199
		7.3.2 EMPLOYMENT IN WIND ENERGY AND BIOMASS	200
		7.3.3 EMPLOYMENT IN GEOTHERMAL AND WAVE POWER	201

## TABLE OF CONTENTS CONTINUED

7.3.4 EMPLOYMENT IN SOLAR PHOTOVOLTAICS AND SOLAR THERMAL POWER	202	10.5.3 HVAC	256
7.3.5 EMPLOYMENT IN THE RENEWABLE HEATING SECTOR	203	10.5.4 HVDC LCC	257
<b>CHAPTER 8: THE SILENT ENERGY MARKET [R]EVOLUTION</b>	<b>204</b>	10.5.5 HVDC VSC	257
<b>8.1 THE POWER PLANT MARKET 1970 TO 2011</b>	<b>205</b>	<b>10.6 RENEWABLE HEATING AND COOLING TECHNOLOGIES</b>	<b>259</b>
8.1.1 POWER PLANT MARKETS IN THE US, EUROPE AND CHINA	207	10.6.1 SOLAR THERMAL TECHNOLOGIES	259
<b>8.2 THE GLOBAL MARKET SHARES IN THE POWER PLANT MARKET: RENEWABLES GAINING GROUND</b>	<b>210</b>	10.6.2 GEOTHERMAL, HYDROTHERMAL AND AERO-THERMAL ENERGY	262
<b>8.3 THE FIRST DECADE: THE DEVELOPMENT OF THE RENEWABLE POWER PLANT MARKET</b>	<b>211</b>	10.6.3 HEAT PUMP TECHNOLOGY	264
8.3.1 THE RENEWABLE POWER SECTOR IN 2014 - REN21'S ANALYSIS	211	10.6.4 BIOMASS HEATING TECHNOLOGIES	266
<b>8.4 THE GLOBAL RENEWABLE ENERGY MARKET IN 2014</b>	<b>212</b>	10.6.5 BIOGAS	267
		10.6.6 STORAGE TECHNOLOGIES	267
<b>CHAPTER 9: ENERGY RESOURCES AND SECURITY OF SUPPLY</b>	<b>214</b>	<b>CHAPTER 11: ENERGY EFFICIENCY – MORE WITH LESS</b>	<b>270</b>
<b>9.1 THE ENERGY [R]EVOLUTION FOSSIL FUEL PATHWAY</b>	<b>216</b>	11.1 METHODOLOGY FOR THE ENERGY DEMAND PROJECTIONS	271
9.1.1 OIL	216	11.1.1 STEP 1: DEFINITION OF A REFERENCE DEMAND SCENARIO	271
9.1.2 GAS	217	11.1.2 STEP 2: DEVELOPMENT OF LOW ENERGY DEMAND SCENARIOS	271
9.1.3 SHALE GAS	218	<b>11.2 ENERGY CONSUMPTION IN THE YEAR 2012</b>	<b>272</b>
9.1.4 COAL	219	<b>11.3 REFERENCE DEMAND SCENARIO</b>	<b>274</b>
9.1.5 NUCLEAR	219	<b>11.4 EFFICIENCY MEASURES AND POTENTIALS</b>	<b>277</b>
<b>9.2 RENEWABLE ENERGY</b>	<b>220</b>	11.4.1 EFFICIENCY MEASURES IN INDUSTRY	277
<b>9.3 GREENPEACE PRINCIPLES AND CRITERIA FOR SUSTAINABLE BIOENERGY</b>	<b>223</b>	11.4.2 EFFICIENCY MEASURES IN BUILDINGS	280
9.3.1 POLICY RECOMMENDATIONS	224	<b>11.5 EFFICIENCY PATHWAYS OF THE ENERGY [R]EVOLUTION</b>	<b>282</b>
9.3.2 BIOENERGY AND CLIMATE	224	11.5.1 LOW DEMAND SCENARIO FOR INDUSTRY SECTOR	282
		11.5.2 LOW DEMAND SCENARIO FOR BUILDINGS AND OTHER SECTORS	283
<b>CHAPTER 10: ENERGY TECHNOLOGIES</b>	<b>226</b>	<b>11.6 DEVELOPMENT OF ENERGY INTENSITIES</b>	<b>284</b>
<b>10.1 FOSSIL FUEL TECHNOLOGIES</b>	<b>227</b>	<b>CHAPTER 12: TRANSPORT</b>	<b>286</b>
10.1.1 COAL COMBUSTION TECHNOLOGIES	227	<b>12.1 THE FUTURE OF THE TRANSPORT SECTOR IN THE REFERENCE SCENARIO</b>	<b>288</b>
10.1.2 GAS COMBUSTION TECHNOLOGIES	227	<b>12.2 TECHNICAL AND BEHAVIOURAL MEASURES TO REDUCE TRANSPORT ENERGY CONSUMPTION</b>	<b>289</b>
<b>10.2 CARBON REDUCTION TECHNOLOGIES AND CARBON CAPTURE AND STORAGE (CCS)</b>	<b>228</b>	12.2.1 BEHAVIOURAL MEASURES TO REDUCE TRANSPORT ENERGY DEMAND	289
10.2.1 CARBON DIOXIDE STORAGE	228	<b>12.3 PROJECTION OF THE FUTURE CAR MARKET</b>	<b>303</b>
10.2.2 CARBON STORAGE AND CLIMATE CHANGE TARGETS	229	12.3.1 PROJECTION OF THE FUTURE TECHNOLOGY MIX	303
<b>10.3 NUCLEAR TECHNOLOGIES</b>	<b>229</b>	12.3.2 PROJECTION OF THE FUTURE VEHICLE SEGMENT SPLIT	303
<b>10.4 RENEWABLE POWER TECHNOLOGIES AND HEATING TECHNOLOGIES</b>	<b>230</b>	12.3.3 PROJECTION OF THE FUTURE SWITCH TO ALTERNATIVE FUELS	304
10.4.1 SOLAR POWER (PHOTOVOLTAICS)	232	12.3.4 PROJECTION OF THE FUTURE KILOMETRES DRIVEN PER YEAR	304
10.4.2 PV CELLS AND MODULES	233	<b>12.4 CONCLUSION</b>	<b>306</b>
10.4.3 PV SYSTEMS	233	<b>CHAPTER 13: GLOSSARY, REFERENCES &amp; APPENDIX</b>	<b>307</b>
10.4.4 CONCENTRATING SOLAR POWER (CSP)	234	<b>13.1 REFERENCES</b>	<b>308</b>
10.4.5 CSP - THERMAL STORAGE	237	<b>13.2 GLOSSARY OF COMMONLY USED TERMS AND ABBREVIATIONS</b>	<b>311</b>
10.4.6 WIND POWER	238	<b>13.3 LIST OF FIGURES AND TABLES</b>	<b>312</b>
10.4.7 BIOMASS ENERGY	241	<b>13.4 RESULTS DATA</b>	<b>316</b>
10.4.8 BIOMASS TECHNOLOGY	241	<b>13.5 2005 – 2015 – ONE DECADE OF ENERGY [R]EVOLUTION SCENARIOS</b>	<b>360</b>
10.4.9 BIOENERGY AND GREENHOUSE GAS (GHG) EMISSION REDUCTION	244	<b>13.6 OVERVIEW OF THE ENERGY [R]EVOLUTION CAMPAIGN SINCE 2005</b>	<b>361</b>
10.4.10 GEOTHERMAL ENERGY	245		
10.4.11 ENHANCED GEOTHERMAL SYSTEMS (EGS)	246		
10.4.12 HYDROPOWER	247		
10.4.13 OCEAN ENERGY	249		
<b>10.5 POWER GRID TECHNOLOGIES – INFRASTRUCTURE FOR RENEWABLES</b>	<b>254</b>		
10.5.1 DEMAND SIDE MANAGEMENT	254		
10.5.2 “OVERLAY” OR “SUPER GRID” – THE INTERCONNECTION OF SMART GRIDS	255		

# INTRODUCTION



IMAGE GEMASOLAR, A 15 MW SOLAR POWER TOWER PLANT, SPAIN.

The good news first: the Energy [R]evolution is already happening! Since the first edition was published in 2005, costs for wind power and solar photovoltaics (PV) have dropped dramatically and markets have grown substantially. Between 2005 and the end of 2014 over 496,000 MW of new solar and wind power plants have been installed – equal to the total capacity of all coal and gas power plants in Europe! In addition 286,000 MW of hydro-, biomass-, concentrated solar- and geothermal power plants have been installed, totaling 783,000 MW of new renewable power generation connected to the grid in the past decade – enough to supply the current electricity demand of India and Africa combined.

Renewable power generation has become mainstream in recent years. Onshore wind is already the most economic power source for new capacity in a large and growing number of markets, while solar PV is likely to follow within the next 3 to 5 years. Utilities in Europe, North America and around the globe are feeling the pressure from renewables, and the old business models are starting to erode. In Germany, where the capacity of solar PV and wind power is equal to peak demand, utilities like RWE and E.on struggle. More and more customers generate their own power. The future business model for utilities will have to change from selling kilowatt-hours to selling energy services if they are to survive.

However, with all the good news from the renewable power sector, the overall transition away from fossil and nuclear fuels to renewables is far too slow to combat dangerous climate change. During the past decade almost as much capacity of new coal power plants has been installed as renewables: 750,000 MW. Over 80% of the new capacity has

been added in China, where not only wind and solar power lead their respective global markets, but also new coal.

But there are the first positive signs that the increase in coal use is coming to an end in China. The amount of coal being burned by China has fallen for the first time this century in 2014, according to an analysis of official statistics. China's booming coal in the last decade has been the major contributor to the fast-rising carbon emissions that drive climate change, making the first drop a significant moment.

## 100% RENEWABLES – A REVOLUTIONARY IDEA GETS MORE AND MORE SUPPORT

Phasing out nuclear and fossil fuels entirely is still a revolutionary idea and many energy experts are skeptical. However, more and more scientists, engineers and activists actively promote a 100% renewable energy vision. According to the IPCC's latest assessment report, we have already used almost 2/3 of our carbon budget, if we are to have a reasonable chance of limiting global mean temperature rise to 2 degrees C. At the current and projected rate of consumption, this entire budget will be used by 2040. So it is essential that we move rapidly towards a new form of energy supply – one that delivers 100% renewable energy by 2050.

Greenpeace and its renewable industry association partners have been researching and presenting Energy [R]evolution scenarios since 2005, and more recently has started collaborating with the scientific community. While our predictions on the potential and market growth of renewable energy may have seemed fanciful or unrealistic, they have



proved to be accurate.<sup>1</sup> The 2015 edition of the global Energy [R]evolution features: 1) a 100% renewable energy scenario for the first time; 2) a basic Energy [R]evolution case with a final energy share of 83% renewables which follows the pathway for the E[R] published in 2012; and 3) and the IEA's World Energy Outlook 2014 Current Policies scenario extrapolated out to 2050- which serves as a reference case.

### THE TRANSPORT [R]EVOLUTION HAS NOT REALLY STARTED YET

While the transition towards 100% renewables in the "traditional" power and heating sector seems well within our grasp, the phase-out of fossil fuels in the transport- and parts of the industry sector are still present major challenges, especially air travel and transport. Oil dominates the global transport system and a switch from combustion engines to electric drives is not possible for example for airplanes.. The "transport revolution" is not simply a technology change; it requires new mobility concepts and the auto industry need to change just like utilities, from selling a product – such as cars – to selling mobility services. Increased shares of e-mobility will increase the overall power demand significantly, adding more pressure on utilities to provide more electricity while phasing out coal and nuclear power plants. Electric mobility must go hand in hand with renewable energy expansion, as an electric car supplied by coal power plant would emit nearly as much if not more CO<sub>2</sub> than an efficient one with a combustion engine.

### NEW FOSSIL FUELS – A HIGH-RISK INVESTMENT

The Energy [R]evolution scenario provides a pathway to phase-out the use of oil roughly at the pace of the depletion rates of existing oil fields. However, while we grapple with meeting the climate challenge, companies and governments are spending billions to develop new oil production which we cannot use. The financial community is waking up to the risks associated with not only investments in new production which may become 'stranded assets', but the risks to the value of the existing reserves carried by fossil fuel companies (and governments, for that matter). The Bank of England<sup>2</sup> and others have started to assess the risk to the global economy from potentially wiping trillions of dollars' worth of 'unburnable carbon' assets off the balance sheets of fossil fuel companies. Viewed in this context, environmentally and economically risky projects to develop new oil and gas fields in the Arctic, or in deep waters off Brazil and in the Gulf of Mexico, are high stakes gambles risking not only our future but the stability of the global economy as well.

While road and rail transport for people will move step by step toward electric drives, heavy duty freight will replace oil with synfuels, hydrogen or bio mass. Aviation and shipping will have to rely on fuels for the foreseeable future – and these fuels need to come from renewable energies as well. Due to strict sustainability criteria for biomass, the Energy [R]evolution scenario only uses a very limited amount which needs to be used wisely. Thus bio mass will be used mainly for aviation,

shipping (in combination with fuel saving concepts like second generation wind drives) and to provide industrial process heat.

### EDUCATION – THE FUEL OF THE FUTURE

A 100% renewable energy supply requires changes in all sectors and it is not just a technology switch, but goes hand in hand with development of new business concepts and policies which support them. New, lighter and sustainable materials, and software development for better integrated "system thinking" requires continuous research and education. New electricity and energy market designs at both the wholesale and retail level will be required to send the right price signals. New jobs will be created while others will disappear. Investment in Universities and Schools pays off better than investments in fossil fuel projects.

### JUST TRANSITION – DON'T LEAVE THE WORKERS BEHIND

Currently there are almost 10 million workers in the global coal industry, and our calculations show that the solar photovoltaic industry could employ the same number of workers in only 15 years from now. The wind industry could grow by a factor of 10 from the current 700,000 employees to over 7 million by 2030 – twice as many as in the global oil- and gas industry today. However, this transition will have to be organized and training programs are needed to educate new workers and maintain social stability for energy workers as a whole. Even the 100% Energy [R]evolution scenario still requires 2 million coal workers in 2030 -there is still a generation to organize the shift so no-one is left behind. But the transition must start now.

### BARRIERS TOWARDS 100% RENEWABLES? THE LACK OF CONSISTENT CLIMATE AND ENERGY POLICIES!

A shift towards 100% renewables is possible within one generation. A baby born in 2015 can witness a fossil fuel free world by the age of 35 – but climate and energy policies globally need to pave the way away from climate chaos towards a sustainable energy supply for all.

The upcoming UNFCCC climate conference in Paris needs to deliver mandatory policies for all countries. This could establish the basis of a truly sustainable energy future.



**Steve Sawyer**  
SECRETARY GENERAL  
GLOBAL WIND ENERGY  
COUNCIL (GWEC)

**Oliver Schäfer**  
PRESIDENT  
SOLAR POWER EUROPE



**Sven Teske**  
PROJECT LEADER ENERGY [R]EVOLUTION  
/GREENPEACE INTERNATIONAL

#### REFERENCES

- 1 LINK TO REPORT: [HTTP://WWW.MC-GROUP.COM/THE-RENEWABLE-ENERGY-REVOLUTION/](http://www.mc-group.com/the-renewable-energy-revolution/)
- 2 SEE [HTTP://WWW.CARBONTRACKER.ORG/NEWS/BANK-OF-ENGLANDS-MOMENTOUS-MOVE-ON-CLIMATE-CHANGE/](http://www.carbontracker.org/news/bank-of-englands-momentous-move-on-climate-change/) AND [HTTP://WWW.BLOOMBERG.COM/NEWS/ARTICLES/2014-12-18/BANKERS-SEE-1-TRILLION-OF-INVESTMENTS-STRANDED-IN-THE-OIL-FIELDS](http://www.bloomberg.com/news/articles/2014-12-18/bankers-see-1-trillion-of-investments-stranded-in-the-oil-fields)

## EXECUTIVE SUMMARY



**IMAGE** ADELE ISLAND, OFF OF AUSTRALIA'S NORTH COAST. MADE UP OF A SERIES OF BEACH RIDGES BUILT BY SANDS WASHED UP FROM THE SURROUNDING SANDBANKS DURING STORMS. THE HIGHEST POINT IS LITTLE MORE THAN 4 METERS (13 FEET) ABOVE SEA LEVEL ON THIS GRASSY BUT TREELESS ISLAND. A SOLAR-POWERED LIGHTHOUSE APPEARS AS A TINY WHITE DOT AT THE NORTH TIP OF THE ISLAND. ADELE ISLAND HAS BEEN CLASSIFIED AS AN IMPORTANT BIRD AREA BECAUSE IT IS A BREEDING SITE OF WORLD IMPORTANCE FOR LESSER FRIGATEBIRDS AND THREE OTHER SPECIES.

Energy [R]evolution scenarios have become a well-known and respected energy analysis since first published in 2005. In the third version of the Energy [R]evolution published in June 2010 in Berlin, we reached out to the scientific community to a much larger extent. The IPCC's *Special Report Renewables* (SRREN) chose the Energy Revolution as one of the four benchmark scenarios for climate mitigation energy pathways, because it was the most ambitious scenario: combining an uptake of renewable energy and energy efficiency, it put forwards the highest renewable energy share by 2050. Following the publication of the SRREN in May 2011 in Abu Dhabi, the ER became a widely quoted energy scenario and is now part of many scientific debates and referenced in numerous scientific peer-reviewed publications.

In March 2015, the Energy [R]evolution received worldwide recognition when a widely circulated report from the US-based *Meister Consultants Group* concluded that the rapid market growth of renewable power generation has been largely underestimated and reported that “*just about no one saw it coming. The world's biggest energy agencies, financial institutions, and fossil fuel companies, for the most part, seriously underestimated just how fast the clean power sector could and would grow*”. Meister identifies one group that got the market scenario closest to right, however, and it

wasn't the International Energy Agency or Goldman Sachs or the US Department of Energy (DOE) – it was Greenpeace with the Energy [R]evolution project.

The basic principles and strategic approach of the development of the Energy [R]evolution concepts have not significantly changed since the beginning. They still serve as a basis for scenario modeling. However, the methodology and underlying scientific research about transport technologies and concepts, energy resource assessments, infrastructural requirements, technology developments, and the cost of renewables have been continuously updated and improved. The renewable energy targets have been increased from 50% to 80% and finally to 100% by 2050.

Since the first Energy [R]evolution was published a decade ago, the energy sector has changed significantly. Renewable energy technologies have become mainstream in most countries as a consequence of dramatically reduced costs. A future renewable energy supply is no longer science fiction, but work in progress.

However, the growth rates of renewables – especially in the heating sector and in transport – are far too slow to achieve the energy-related CO<sub>2</sub> reductions required to avoid dangerous climate change. A fundamental shift in the way we consume and generate energy must begin immediately and be well

underway before 2020 in order to avert the worst impacts of climate change.<sup>1</sup> We need to limit global warming to less than 2° Celsius, above which the impacts become devastating.

#### CLIMATE CHANGE IS NOT A PREDICTION ANYMORE – IT IS REALITY

The world's energy supply has bestowed great benefits on society, but it has also come with high price tag. The world's most rigorous scientific bodies are in agreement on climate change, which is occurring due to a build-up of greenhouse gases, especially carbon dioxide, in the atmosphere caused by human activity.

Globally, most fossil fuel is used to generate energy, either electricity, heat, or motor fuel. We have evidence that, if unchanged, the growth of fossil energy will lead to unmanageable impacts on the global population.

Climate change threatens all continents, living systems, coastal cities, food systems and natural systems. It will mean more natural disasters like fire and floods, disruption to food growing patterns and damage to property as sea levels rise.

If we remain dependent on fossil fuel in the pursuit of energy security, the result will be a potentially catastrophic spiral towards increasing greenhouse gas emissions and more extreme climate impacts. The need for more fuels is driving the industry towards unconventional sources, like shale oil and gas, and gigantic coal mines, which destroy ecosystems and put water supply in danger. Relying on a fuel that has a fluctuating cost on the global market is also harmful to economies. The use of nuclear energy is sometimes touted as a climate change solution, but it is simply not viable. Apart from being too dangerous and too slow to develop, it is also incredibly expensive if all economic costs over plant lifetime are taken into account.

Furthermore, by switching to unconventional sources, we extract more carbon from the ground. Yet, since the International Energy Agency coined the term “un-burnable carbon,” the consensus is that we must leave most (around two thirds) of our current carbon resources in the ground if the world is to stay within its carbon budget. The more unconventional fuels we add to our resources, the less likely staying within an increase of two degrees Celsius becomes. According to the IPCC identified the remaining carbon budget: humankind cannot emit more than 1,000 gigatonnes of CO<sub>2</sub> from now. Therefore it is essential to move rapidly towards a decarbonized energy system – in ideal case one that delivers 100% renewable energy by 2050.

#### THE ON-GOING ENERGY REVOLUTION IS STILL FAR TOO SLOW

The International Energy Agency published an evaluation of the current development of the energy sector in May 2015 (IEA – TCEP 2015),<sup>2</sup> which concluded that the implementation of renewables and energy efficiency is successful but too slow to meet the 2°C target. Here are some of the IEA's conclusions:

**Costs:** Increasingly, renewables are competitive with new fossil fuel plants, and the cost gap between renewable electricity and fossil power from new plants is closing worldwide. Nonetheless, markets still do not reflect the true environmental cost of power generation from fossil fuels.

**Policy:** Power markets must be redesigned to accommodate variable, distributed renewables. Obstacles still exist for the financing of renewable energy projects and grid connections, thereby slowing down the transition. But the worst policy mistakes are uncertainty and retroactive changes.

**Technology:** Cogeneration and renewable heat have both grown in absolute terms but are not increasing quickly enough as a share of energy supply. The share of cogeneration in power supply has even stagnated. Likewise, battery storage has mainly been developed for mobility up to now but is increasingly used for frequency regulation to integrate a greater share of variable renewables.

**Mobility:** Electric vehicles are catching on, with an increasing number of manufacturers now offering hybrid and electric options. Fuel efficiency standards have also made light vehicles more efficient. The standard should now be applied to larger trucks and buses.

**Buildings:** The technologies are available, and targets are in place in many regions. However, the rate and depth of energy-efficient renovations needs to increase for true progress to be made in this sector because the building stock has a service life counted in decades.

The *Renewable Policy Network for the 21st Century* (REN21) has undertaken a global renewable market analysis each year in June since 2004. The publication – “Renewables – Global Status Report” – is among the most comprehensive global and national surveys of the renewable industry sector. According to the latest edition, the global renewable energy market in 2014 was dominated by three power generation technologies: solar photovoltaics (PV), wind, and hydro. Combined, these technologies added 127 GW of new power generation capacity worldwide. By year's end, renewables made up an estimated 60% of net additions to the global power capacity. In several countries renewables represented a higher share of added capacity (REN21-2015).<sup>3</sup> The increase in market volume and strong global competition led to significant cost reductions, especially for solar PV and wind power. As a result, other renewable energy technologies were under pressure to lower costs, particularly in the heating sector due to the increased competitiveness of electricity-based heating systems. Cost-competitive solar PV in combination with electrical heat pumps have become economically viable, negatively impacting the solar thermal collector market.

#### REFERENCES

- 1 IPCC – SPECIAL REPORT RENEWABLES, CHAPTER 1, MAY 2011.
- 2 (IEA – TCEP 2015) TRACKING CLEAN -ENERGY PROGRESS 2015; ENERGY TECHNOLOGY PERSPECTIVES 2015 EXCERPT; IEA INPUT TO THE CLEAN ENERGY MINISTERIAL; INTERNATIONAL ENERGY AGENCY; 9 RUE DE LA FEDERATION; 75739 PARIS CEDEX 15, FRANCE; WWW.IEA.ORG.
- 3 (REN21-2015); RENEWABLES 2015 GLOBAL STATUS REPORT, PARIS: REN21 SECRETARIAT; WWW.REN21.NET; ISBN 978-3-9815934-6-4

While developments in the renewable energy, heating and cooling sector were slower than in the power sector, the markets for solar thermal collectors and geothermal heat pumps grew by 9%. Bio-heat production remained stable in 2014, increasing only 1% from 2013 levels. The lack of infrastructure for heating systems and an uncertain policy environment impeded the development of the renewable energy heating market (REN21-2015).

The number of electric vehicles worldwide doubled year over year to 665,000. E-mobility and recent developments in battery storage (including significant cost reductions) are likely to change the future role of renewable energy in the transport sector. Biofuels, however, are still the main renewable fuel source in the transport sector; they grew by 8.4% in 2014 compared the previous year (REN21-2015).

In conclusion, developments in the heating/cooling sector and the transport sector in particular are far too slow. Despite all the success in the renewable power sector, the extreme growth of coal power generation, especially in China, undercuts many successes with renewables. However, the first sign of a stagnation of coal demand in China – even a small decline for the first time in 2014 – provides reason to hope. The political framework of energy markets must adapt to the newly emerging, mostly distributed energy technologies in order to support the transition to 100% renewable energy supply.

Thus, Energy [R]evolution has begun, especially in the power sector, but heating and transport significantly lag behind. Overall, the transition from fossil and nuclear fuels to renewables is too slow, and energy demand is still growing too quickly.

#### LESS IS MORE

Using energy efficiently is cheaper than producing new energy from scratch and often has many other benefits. An efficient clothes washing machine or dishwasher, for example, uses less power and saves water, too. Efficiency in buildings doesn't mean going without – it should provide a higher level of comfort. For example, a well-insulated house will feel warmer in the winter, cooler in the summer and be healthier to live in. An efficient refrigerator is quieter, has no frost inside or condensation outside, and will probably last longer. Efficient lighting offers more light where you need it. Efficiency is thus really better described as 'more with less'.

#### THE TRANSPORT REVOLUTION MUST START IN MEGACITIES

Sustainable transport is needed just as much as a shift to renewable electricity and heat production in order to reduce the level of greenhouse gases in the atmosphere. Today, just over one fourth (27%) (IEA WEO SR 2015) of current energy use comes from the transport sector, including road and rail, aviation and sea transport. By the end of 2013, 92.7% of all transport energy need came from oil products, 2.5% from

biofuels and only 1% from electricity (IEA WEO SR 2015). A transition from fossil fuels to renewable electricity – either directly or via synthetic fuels – for the entire global transport sector is required in order to phase-out carbon emissions. This is one of the most difficult parts of the Energy [R]evolution and requires a true technical revolution. It is ambitious but nevertheless possible with currently available technologies for land-based and other transport.

14% of all fossil transport fuels are used for “bunker fuel,” meaning transport energy for international shipping and international air transport. In order to replace bunker fuels entirely with renewables, a combination of energy efficiency and renewable fuels is required. Both the marine and aviation sector can start this transition, but we need more research and development along the way towards a truly 100% renewable system. Biofuels and synfuels – produced with renewable electricity – are the only realistic renewable energy option for planes currently and for the next decade. For ships, new wind-based drives, such as new generation sails and Flettner rotors, are needed to replace some engine fuels.

The transport [R]evolution, however, must start in (mega)cities, where a modular shift from individual to efficient and convenient public transport systems powered by renewable electricity is possible in a short time frame and with currently available technologies. Political action is the main barrier in changing land-based transport systems.

#### THE GLOBAL ENERGY [R]EVOLUTION – KEY RESULTS

Renewable energy sources accounted for 12% the world's primary energy demand in 2012. The main sources of today are biomass and hydro, which are mostly used for heating and transport but increasingly in the power sector as well.

For electricity generation, renewables contribute about 21%, just as for heat supply (21%). While solar photovoltaic and wind revolutionize the power sector with increasing shares, hydropower remains the largest renewable source. Biomass is the number one source for renewable heating. However, geothermal heat pumps and solar thermal collectors increasingly contribute as well. About 81.2% of the primary energy supply today still comes from fossil fuels energy.

The two Energy [R]evolution scenarios describe development pathways to a sustainable energy supply, achieving the urgently needed CO<sub>2</sub> reduction target and a nuclear phase-out, without unconventional oil resources. The key results of the global Energy [R]evolution scenarios are the following:

- Use energy wisely: Combining the projections on population development, GDP growth and energy intensity results in future development pathways for the world's final energy demand. Under the Reference scenario, total final energy demand increases by 65% from the current 326,900 PJ/a to 539,000 PJ/a in 2050. In the basic Energy [R]evolution scenario, final energy demand decreases by 12% compared to current consumption and is expected to reach

289,000 PJ/a by 2050. The Advanced scenario will shift the energy demand trends; the peak will be reached in 2020 with a total consumption of 355,000 PJ/a – 7% below the Reference case - and remain at that level for about a decade. Due to a faster electrification of the transport sector including higher shares of public transport the overall final energy demand drops below current levels before 2040 and reaches 279,000 PJ/a by 2050 – 15% below the current global demand.

- **Electricity replaces fuels:** Under both Energy [R]evolution scenarios, due to economic growth, increasing living standards and electrification of the transport sector, overall electricity demand is expected to increase despite efficiency gains in all sectors. Total electricity demand will rise from about 18,860 TWh/a in 2012 to 37,000 TWh/a by 2050 in the basic Energy [R]evolution scenario. Compared to the Reference scenario, efficiency measures in the industry, residential and service sectors avoid the generation of about 16,700 TWh/a. This reduction can be achieved in particular by introducing highly efficient electronic devices using the best available technology in all demand sectors.

The transformation to a carbon free 100% renewable energy system in the Advanced Energy [R]evolution scenario will further increase the electricity demand in 2050 up to more than 40,000 TWh/a. Electricity will become the major renewable 'primary' energy, not only for direct use for various purposes but also for the generation of synthetic fuels for fossil fuels substitution. Around 8,100 TWh are used in 2050 for electric vehicles and rail transport, around 5,100 TWh for hydrogen and 3,600 TWh for synthetic liquid fuel generation for the transport sector (excluding bunkers).

- **Reducing global heat demand:** Efficiency gains in the heating sector are even larger than in the electricity sector. Under both Energy [R]evolution scenarios, consumption equivalent to about 76,000 PJ/a is avoided through efficiency gains by 2050 compared to the Reference scenario. As a result of energy-related renovation of the existing stock of residential buildings, the introduction of low energy standards and 'passive climatisation' for new buildings, as well as highly efficient air conditioning systems, enjoyment of even greater comfort and better energy services will be accompanied with much lower future energy demand.
- **Electricity Generation:** The development of the electricity supply sector is characterised by a dynamically growing renewable energy market and an increasing share of renewable electricity. This trend will more than compensate for the phasing out of nuclear power production in the Energy [R]evolution scenarios, continuously reducing the number of fossil fuel-fired power plants as well. By 2050, 92% of the electricity produced worldwide will come from renewable energy sources in the basic Energy [R]evolution scenario. 'New' renewables – mainly wind, PV, CSP and

geothermal energy – will contribute 68% to the total electricity generation. Already by 2020, the share of renewable electricity production will be 31% and 58% by 2030. The installed capacity of renewables will reach about 7,800 GW in 2030 and 17,000 GW by 2050.

A 100% electricity supply from renewable energy resources in the Advanced scenario leads to around 23,600 GW installed generation capacity in 2050. By 2020, wind and PV will become the main contributors to the growing market share. After 2020, the continuing growth of wind and PV will be complemented by electricity from solar thermal, geothermal and ocean energy. The Energy [R]evolution scenarios will lead to a high share of flexible power generation sources (PV, wind and ocean) of already 31% to 36% by 2030 and 53% to 55% by 2050. Therefore, smart grids, demand side management (DSM), energy storage capacities and other options need to be expanded in order to increase the flexibility of the power system for grid integration, load balancing and a secure supply of electricity.

- **Future Costs of Electricity Generation:** The introduction of renewable technologies under both Energy [R]evolution scenarios slightly increases the future costs of electricity generation compared to the Reference scenario by 2030. However, this difference in full cost of generation will be minor with around 0.2 US\$ cent/kWh in both the basic E[R] and the 100% renewables Advanced scenario, however, without taking into account potential integration costs for storage or other load-balancing measures. Due to increasing prices for conventional fuels, electricity generation costs will become economically favourable across all world regions starting in 2030 under the Energy [R]evolution scenarios. In some countries such as China and India, the Energy [R]evolution pathway – under the assumption of global fuel price paths – is economical from the very beginning and cheaper than conventional power supply after 2020 already. By 2050, the average global generation costs in the basic Energy [R]evolution will be 2.5 US\$ cent/kWh below the Reference case, while the Advanced scenario achieves lower cost savings due to higher capacity needs (1.7 US\$ cents/kWh below the Reference case).
- **The future electricity bill:** Under the Reference scenario, on the other hand, growth in demand and increasing fossil fuel prices result in total electricity supply costs rising from today's US\$ 2.06 trillion per year to more than US\$ 5.35 trillion in 2050, compared to 19% lower costs (US\$ 4.3 trillion) in the basic E[R] scenario due to increasing energy efficiency and shifting energy supply to renewables.

The Advanced scenario with 100% renewable power replaces more fossil fuels with electricity and therefore leads to higher overall generation costs of US\$ 6.2 trillion by 2050 but savings in fuel supply costs especially for the transport and industry sector due to a fossil fuel phase-out. Both Energy [R]evolution scenarios not only comply with

world's CO<sub>2</sub> reduction targets, but also help stabilise energy costs and relieve the economic pressure on society.

- World: future investments in the power sector: Around US\$ 48 trillion is required in investment for the Energy [R]evolution scenario to become reality (including investments for replacement after the economic lifetime of the plants) - approximately US\$ 1.23 trillion per year, about 50% more than in the Reference case (US\$ 24.5 trillion or 0.63 trillion per year). Investments for the Advanced scenario add up to US\$ 64.6 trillion by 2050, on average US\$ 1.66 trillion per year, including high investments in additional power plants for the production of synthetic fuels. Under the Reference scenario, the level of investment in conventional power plants adds up to almost 50%, while the other half would be invested in renewable energy and cogeneration by 2050.

Under both Energy [R]evolution scenarios, however, around 95% of the entire investment in the power sector would shift towards renewables and cogeneration. By 2030, the fossil fuel share of power sector investment would be focused mainly on gas power plants.

Because renewable energy has no fuel costs, the fuel cost savings in the basic Energy [R]evolution scenario reach a total of US\$ 39 trillion by 2050, approximately US\$ 1 trillion per year. The total fuel cost savings would therefore cover 170% of the total additional investments compared to the Reference scenario. Fuel cost savings in the Advanced scenario are even higher and add up to US\$ 42 trillion, or US\$ 1.1 trillion per year. Thus additional investment under the Advanced scenario would be covered entirely (107%) by fuel cost savings. Renewable energy sources would then go on to produce electricity without any further fuel costs beyond 2050, while costs for coal and gas would continue to be a burden on national economies.

- World: energy supply for heating: Today, renewables meet around 21% of the global energy demand for heating, the main contribution coming from the use of biomass. Dedicated support instruments are required to ensure a dynamic development in particular for renewable technologies for buildings and renewable process heat production. In Energy [R]evolution scenarios, renewables provide 42% (basic) and 43% (advanced) of global heat demand in 2030 and 86% / 94% in 2050 respectively.
  - Energy efficiency measures help to reduce the currently growing energy demand for heating by 33 % in 2050 (relative to the Reference scenario), in spite of improving living standards and economic growth.
  - In the industry sector solar collectors, geothermal energy (incl. heat pumps) as well as electricity and hydrogen from renewable sources are increasingly substituting for fossil fuel-fired systems.

- A shift from coal and oil to natural gas in the remaining conventional applications leads to a further reduction of CO<sub>2</sub> emissions.

Up to 2030, biomass remains the main contributor of the growing market share. After 2030, the continuing growth of solar collectors and a growing share of geothermal and environmental heat as well as heat from renewable hydrogen will further reduce the dependence on fossil fuels. The Advanced scenario results in a complete substitution of the remaining gas consumption by hydrogen generated from renewable electricity.

- World: future investments in the heating sector: In the heating sector, the Energy [R]evolution scenarios also require a major revision of current investment strategies in heating technologies. In particular, far more solar thermal, geothermal and heat pump technologies need to be installed if these potentials are to be tapped for the heating sector. The use of biomass for heating purposes - often traditional biomass today - will be substantially reduced in the Energy [R]evolution scenarios and replaced by more efficient and sustainable renewable heating technologies.

Renewable heating technologies are extremely variable, from low tech biomass stoves and unglazed solar collectors to very sophisticated enhanced geothermal and solar arrays. Thus, it can only be roughly estimated that the Energy [R]evolution scenario in total requires around US\$ 16.3 trillion to be invested in renewable heating technologies up to 2050 (including investments for replacement after the economic lifetime of the plants) - approximately US\$ 420 billion per year. The Advanced scenario assumes an even more ambitious expansion of renewable technologies resulting in an average investment of around US\$ 429 billion per year, while the main strategy in the scenario is the substitution of the remaining natural gas amounts with hydrogen or other synthetic fuels.

- World: future employment in the energy sector – Reference versus Advanced scenario: The Advanced Energy [R]evolution scenario results in more energy sector jobs globally at every stage of the projection.
  - There are 35.5 million energy sector jobs in the Advanced Energy [R]evolution in 2020, and 29.6 million in the Reference scenario.
  - In 2025, there are 45.2 million jobs in the Advanced Energy [R]evolution scenario, and 29.1 million in the Reference scenario.
  - In 2030, there are 46.1 million jobs in the Advanced Energy [R]evolution scenario and 27.3 million in the Reference scenario.

Jobs in the coal sector decline in both the Reference scenario and the Advanced scenario, as a result of productivity improvements in the industry, coupled with a move away from coal in the Advanced Energy [R]evolution scenario.

In the Reference scenario jobs increase slightly to 2020, after which energy sector jobs decline. This is mainly driven by losses in the coal sector. At 2030, jobs are 4% (2.3 million) below 2015 levels. In the Energy [R]evolution scenario, strong growth in the renewable sector leads to an increase of 25% in total energy sector jobs by 2020, and job numbers are nearly 60% above 2015 levels in 2025. Job numbers continue to rise after 2025, to reach 48 million jobs by 2030.

Renewable energy accounts for 87% of energy jobs by 2030. Solar photovoltaics will provide 9.7 million jobs, equal to the amount of coal jobs today. Employment in the wind sector will increase by a factor of 10 from 0.7 million today to over 7.8 million in 2030, twice as many jobs as the current oil and gas industry.

- World: transport: A key target is to introduce incentives for people to drive smaller cars and use new, more efficient vehicle concepts. In addition, it is vital to shift transport use to efficient modes like rail, light rail and buses, especially in the expanding large metropolitan areas. Along with rising prices for fossil fuels, these changes reduce the further growth in car sales projected under the Reference scenario. Due to population increase, GDP growth and higher living standards, energy demand from the transport sector is expected to increase in the Reference scenario by around 65% from 90,000 PJ/a in 2012 to 148,000 PJ/a in 2050. In the basic Energy [R]evolution scenario, efficiency measures and modal shifts will save 53% (78,700 PJ/a) in 2050 compared to the Reference scenario.

Additional modal shifts and technology switches lead to even higher energy savings in the Advanced scenario of 62% (92,000 PJ/a) in 2050 compared to the Reference scenario. Highly efficient propulsion technology with hybrid, plug-in hybrid and battery-electric power trains will bring about large efficiency gains. By 2030, electricity will provide 9% of the transport sector's total energy demand in the Energy [R]evolution, while in 2050 the share will be 39% in the basic and 52% in the Advanced scenario. Hydrogen and other synthetic fuels generated using renewable electricity are complementary options to further increase the renewable share in the transport sector. In 2050, up to 14,000 PJ/a of hydrogen is used in the transport sector for the Advanced Energy [R]evolution scenario.

- World: development of CO<sub>2</sub> emissions: While the world's emissions of CO<sub>2</sub> will increase by 56% between 2012 and 2050 under the Reference scenario, under the basic Energy [R]evolution scenario they will decrease from 30,470 million tonnes in 2012 to 4,360 million tonnes in 2050. Annual per capita emissions will drop from 4.3 tonne to 0.5 tonne. In spite of the abstinence of nuclear power production and increasing power demand, CO<sub>2</sub> emissions will decrease in the electricity sector. In the long run, efficiency gains and the increased use of renewable electricity in vehicles strongly reduce emissions in the transport sector as well.

With a 31% share of CO<sub>2</sub>, the industry sector will be the largest source of emissions in 2050 in the basic E[R] scenario. By 2050, global CO<sub>2</sub> emissions are around 80% below 1990 levels in the basic Energy [R]evolution scenario.

CO<sub>2</sub> emission peak by 2020: The 100% renewable energy Advanced Energy [R]evolution scenario will decarbonize the entire energy system by 2050. Under that pathway the combination of energy efficiency and renewable energy technologies will lead to a stabilization of global CO<sub>2</sub> emissions by 2020 and a constant reduction towards near zero emissions in 2050.

By 2030, global CO<sub>2</sub> emissions would be back to 1990 levels. Only a decade later, a further 60% reduction is achieved. The total carbon emission between 2012 and 2050 would add up to 667 Gt CO<sub>2</sub> in the Advanced Energy [R]evolution scenario and 744 Gt CO<sub>2</sub> in the basic E[R]. In comparison, the Reference would lead to 1,400 Gt CO<sub>2</sub> between 2012 and 2050 – more than twice as much as under the Advanced scenario bringing the world to a +4°C pathway with disastrous consequences for the global flora and fauna and life-threatening impacts for the humanity. Switching to 100% renewable is therefore a matter of survival.

- World: primary energy consumption: Under the basic E[R] scenario, primary energy demand will decrease by 19% from today's 534,870 PJ/a to around 433,000 PJ/a. Compared to the Reference scenario, overall primary energy demand will be reduced by 50% in 2050 under the E[R] scenario (REF: around 860,000 PJ in 2050). The Advanced scenario results in a slightly primary energy consumption of around 450,000 PJ in 2050 due to additional conversion losses for the production of synthetic-fuels.

The Energy [R]evolution scenario aims to phase out coal and oil as fast as technically and economically possible by expanding renewable energy and quickly rolling out very efficient vehicle concepts in the transport sector to replace oil-powered combustion engines. This leads to an overall renewable final energy share of 42% in 2030 and 72% in 2040 in the Advanced E[R]. By 2050, 100% of all global energy demand is covered with renewables. The only remaining fossil fuels are assumed for non-energy uses, such as petrochemical and steel products.

#### FURTHER RESEARCH IS NEEDED

Further research and development of innovative technologies is a precondition of the Energy [R]evolution and the required fundamental transformation of the energy systems. Thus, the scenarios assume further improvements of performance and costs of plants for electricity and heat generation from renewables, new vehicle concepts and in an implicit way also for other infrastructures such as electricity and heating grids, charging infrastructure, synthetic fuel generation plants or

storages and other load balancing options. The spatial resolution of the scenarios and their development pathways is very coarse distinguishing ten different world regions. Energy systems and aspects such as the refinancing of investment in new capacities are largely determined by specific local and regional conditions. Therefore, the Energy [R]evolution needs more in-depth systems analysis and assessment of alternative pathways and concepts under different framework conditions such as potentials and cost-effectiveness of renewable energy use. Infrastructural needs, economic and societal aspects need to be considered at least country-wise and by more sophisticated methods as it was possible for this study. Such analyses are already done or underway in several countries and regions. Other countries and regions still need more scientific analysis of feasible ways deploying their potentials for efficiency measures and renewable energies and for implementing new technologies in a cost-effective way. To fully understand the Energy [R]evolution requires the use and further development of existing sophisticated modelling approaches such as system dynamics, agent-based modelling of actor's behaviour or dynamic modelling of capacity expansion and operation with high spatial and temporal resolution.

#### **POLICIES REQUIRED FOR A TRANSITION TO 100% ENERGY [R]EVOLUTION:**

To make the Energy [R]evolution a reality, immediate political action is required. There are no economic or technical barriers to move to 100% renewable energy in the long-term. Governments regulate energy markets, both for supply and demand; they can educate everyone from consumers to industrialists and stimulate the markets for renewable energy and energy efficiency by implementing a wide range of economic mechanisms. They can also build on the successful policies already adopted by other countries. To get started, governments need to agree on further binding emission reduction commitments under the UNFCCC process.

Meanwhile, the global emissions landscape is changing rapidly. As a result of declining coal consumption in China, global energy-related CO<sub>2</sub> emissions remained stable in 2014 for the first time in 40 years, despite continued economic growth. If global mitigation endeavours are strengthened, this trend will continue. This new landscape provides a greater chance that the coal, oil and nuclear industries – which continue to fight to maintain their dominance by propagating the outdated notion that citizens need their unsustainable energy – will face dramatic changes in both energy markets and support from governments.

**An effective climate** agreement should include strong short-term action and set out a clear long-term pathway. Key elements include the following:

**A strong long-term goal: Phase-out of fossil fuels and nuclear power by 2050 through a just transition towards 100% renewable energy, as well as the protection and restoration of forests.** A clear signal to decision-makers and investors at all levels that the world is moving towards phasing out carbon emissions entirely and accelerating the transition to 100% renewable energy is needed. Countries' short-term emission reduction commitments must align with this long-term goal and support transformational change, ensuring both fairness and solidarity.

**A 5-year cycle process for country commitments starting in 2020.** All countries' commitments should follow a 5-year commitment period starting in 2020, which would form the first period of the Paris Protocol. Moving forward, each period would further deepen the commitments, allowing no back-sliding. 5-year commitment periods incentivize early action, allow for dynamic political responses and prevent the lock-in of low ambition. They allow for a timely adaptation to the technological advances of renewable energies and energy efficiency.

**Legally binding:** A legally binding protocol - including common accounting rules for mitigation and finance - will compel leaders to act boldly; legally binding obligations are a real expression of political will, ensuring durability in the face of political changes and increased ambition over time.

**Shifting subsidies away from fossil fuels:** All countries should commit to phase-out all subsidies - both for production and consumption - for fossil fuels by 2020.

**Strong commitment for adaptation, finance and loss and damage:** The Paris Protocol should acknowledge that less mitigation action means a greater need for adaptation, especially finance. Consequently, an adaptation goal should be established to ensure that the level of support meets vulnerable countries' needs under the actual warming anticipated. A roadmap must be adopted in Paris to meet the US\$ 100 billion commitment for climate financing by 2020.

**Bring down emissions before 2020.** The gap between the agreed upon goal of keeping warming below 2°C/1.5°C and what countries actually intend to do by 2020 is widely acknowledged. The pledges at the time of this writing (mid-2015) would lead us into a world of 3 or more degrees warming, with all its devastating consequences for humans and ecosystems. While a process on how to bring the emissions down was established at COP17 in 2011, countries are still – four years later – failing to agree upon sufficient action to mitigate greenhouse gases. In Paris at the latest, governments and corporate leaders need to provide innovative solutions for breaking the stalemate and laying the groundwork for bold actions before 2020.



# CLIMATE CHANGE AND NUCLEAR THREATS

THE IMPACTS  
OF CLIMATE CHANGE

CLIMATE CHANGE  
- THE SCIENCE

NUCLEAR THREATS

NO SOLUTION  
TO CLIMATE PROTECTION

THE DANGERS  
OF NUCLEAR POWER



“  
bridging  
the carbon  
gap”

**IMAGE** THE REGION OF BOHAI SEA, YELLOW SEA, AND EAST CHINA IS ONE OF THE MOST TURBID AND DYNAMIC OCEAN AREAS IN THE WORLD. THE BROWN AREA ALONG CHINA'S SUBEI SHOAL IS TURBID WATER COMMONLY SEEN IN COASTAL REGIONS. SHALLOW WATER DEPTHS, TIDAL CURRENTS, AND STRONG WINTER WINDS LIKELY CONTRIBUTED TO THE MIXING OF SEDIMENT THROUGH THE WATER.

© NASA IMAGES BY NORMAN KUBING

The world's power supply has bestowed great benefits on society, but it has also come with high price tag. The world's most rigorous scientific bodies are in agreement on climate change, which is occurring due to a build of greenhouse gases, especially carbon dioxide, in the atmosphere caused by human activity.

Globally, most fossil fuel is used to generate energy, either electricity, heat, or motor fuel. We have evidence that, if unchanged, the growth of fossil energy will lead to unmanageable impacts on the global population.

Climate change threatens all continents, living systems, coastal cities, food systems and natural systems. It will mean more natural disasters like fire and flood, disruption to food growing patterns and damage to property as sea levels rise.

If we remain dependent on fossil fuel in the pursuit of energy security, the result will be a potentially catastrophic spiral towards increasing greenhouse gas emissions and more extreme climate impacts. The need for more fuels is driving the industry towards unconventional sources, like shale oil and gas, and gigantic coal mines, which destroy ecosystems and put water supply in danger. Relying on a fuel that has a fluctuating cost on the global market is also harmful to economies.

Furthermore, by switching to unconventional sources, we extract more carbon from the ground. Yet, since the International Energy Agency coined the term "un-burnable carbon," the consensus is that we must leave most (around two thirds) of our current carbon resources in the ground if the world is to stay within its carbon budget. The more unconventional fuels we add to our resources, the less likely staying within an increase of two degrees Celsius becomes.

The use of nuclear energy as a climate change solution is sometimes touted as a solution, but it is simply not viable. Apart from being too dangerous and too slow to develop, it is also incredibly expensive.

## 1.1 THE IMPACTS OF CLIMATE CHANGE

Every day, we damage our climate by using fossil fuels (oil, coal and gas) for energy and transport. The resulting changes are likely to destroy the livelihoods of millions of people, especially in the developing world, as well as ecosystems and species, over the coming decades. Significantly reducing our greenhouse gas emissions makes both environmental and economic sense.

### BOX 1.1 | WHAT IS THE GREENHOUSE EFFECT?

The greenhouse effect is a natural process, in which the atmosphere traps some of the sun's energy, warming the earth and moderating our climate. Increase in 'greenhouse gases' from human activity has enhanced this effect, artificially raising global temperatures and disrupting our climate. The main greenhouse gas is carbon dioxide - produced by burning fossil fuels and through deforestation. Others include methane from agriculture, animals and landfill sites; nitrous oxide from agricultural production; and a variety of industrial chemicals.

According to the Intergovernmental Panel on Climate Change, the United Nations forum for established scientific opinion, the world's temperature is expected to increase over the next hundred years by up to 4.8° Celsius if no action is taken to reduce greenhouse gas emissions – much faster than anything experienced so far in human history. At more than a 2°C rise, damage to ecosystems and disruption of the climate system increase dramatically. An average global warming of more than 2°C threatens millions of people with an increased risk of hunger, disease, flooding and water shortages.

A certain amount of climate change is now "locked in", based on the amount of carbon dioxide and other greenhouse gases already emitted into the atmosphere since industrialisation. No one knows exactly how much warming is "safe" for life on the planet. However, we know is that the effects of climate change are already impacting populations and ecosystems. We can already see melting glaciers, disintegrating polar ice, thawing permafrost, dying coral reefs, rising sea levels, changing ecosystems, record droughts, and fatal heat waves made more severe by a changed climate.

## 1.2 CLIMATE CHANGE – THE SCIENCE

En November 2014, the 5th Assessment Report of the International Panel on climate change (IPCC) was published. Over 5 years, several hundred climate scientists analysed the latest scientific literature to pull together a comprehensive overview about the latest finds of climate research. This subchapter summarizes the key findings based on the Summary for Policy Makers (SPM).

1.2.1 OBSERVED CHANGES

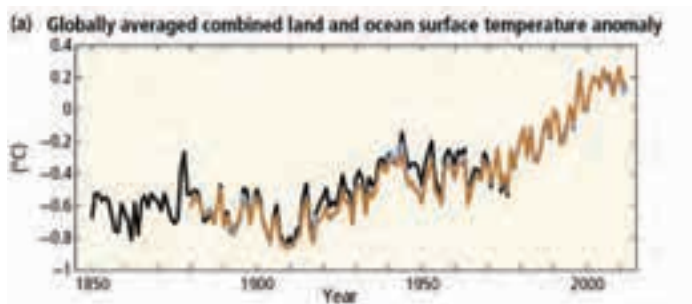
First, the IPCC sees a clear human component in climate change, with anthropogenic greenhouse gas emissions having reached an unprecedented level. The result will be considerable detrimental impacts on “human and natural systems” (IPCC-AR 5 SPM).<sup>1</sup>

There is no question that global warming is happening; indeed, “since the 1950s, many of the observed changes are unprecedented over decades to millennia. The atmosphere and ocean have warmed, the amounts of snow and ice have diminished, and sea level has risen.” (IPCC-AR 5 SPM). The global average temperature per decade at the earth’s surface continues to increase, with 1983 to 2012 likely being “the warmest 30-year period of the last 1400 years in the Northern Hemisphere.” From 1880 to 2012, the planet has warmed up by 0.85 degrees Celsius. (IPCC-AR5-SPM)

Global warming affects the planetary water cycle. Areas with little precipitation have waters of higher salinity because more water is lost through evaporation than precipitation. Globally, these areas are indeed becoming more saline, whereas waters have become fresher in areas of greater precipitation since the 1950s – a clear sign that dry areas are becoming drier while wet areas are getting wetter.

Likewise, the oceans have absorbed more CO<sub>2</sub> since the beginning of industrialization. As a result, ocean surface water has become 26 percent more acidic, with the pH having decreased by 0.1 (IPCC-AR5-SPM).

FIGURE 1.1 | GLOBALLY AVERAGED COMBINED LAND AND OCEAN SURFACE TEMPERATURE ANOMALY

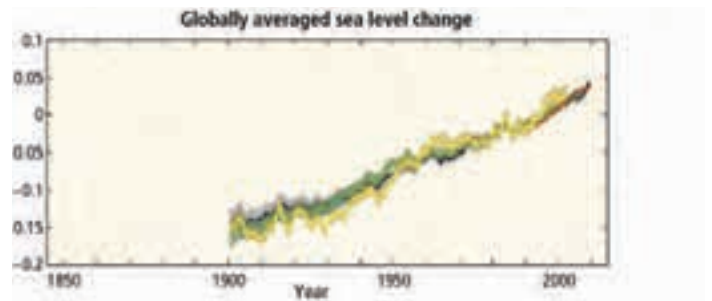


source IPCC-AR5-SPM.

REFERENCES

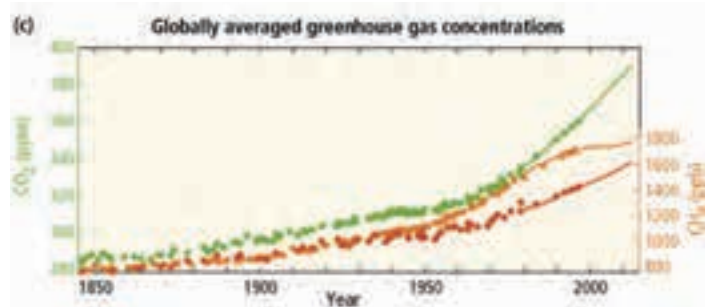
<sup>1</sup> (IPCC-AR5-SPM) INTERNATIONAL PANEL ON CLIMATE CHANGE – 5TH ASSESSMENT REPORT; CLIMATE CHANGE 2014. SUMMARY FOR POLICY MAKERS; [HTTP://IPCC.CH/PDF/ASSESSMENT-REPORT/AR5/SYR/AR5\\_SYR\\_FINAL\\_SPM.PDF](http://ipcc.ch/pdf/assessment-report/ar5/syr/ar5_syr_final_spm.pdf)

FIGURE 1.2 | GLOBALLY AVERAGED SEA LEVEL CHANGE



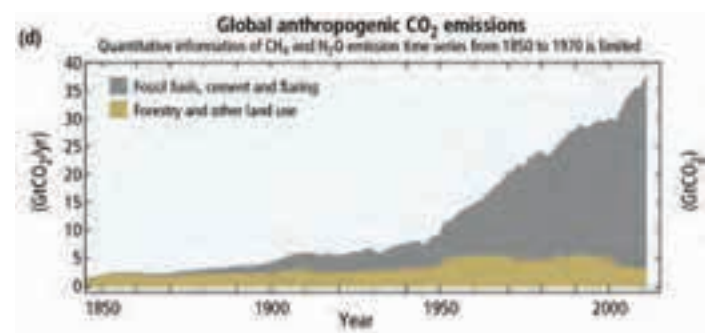
source IPCC-AR5-SPM.

FIGURE 1.3 | GLOBALLY AVERAGED GREENHOUSE GAS CONCENTRATIONS



source IPCC-AR5-SPM.

FIGURE 1.4 | GLOBALLY ANTHROPOGENIC CO<sub>2</sub> EMISSIONS



source IPCC-AR5-SPM.

From 1992 to 2011, the world's largest ice sheets – in Greenland and the Antarctic – also shrank dramatically, and glaciers are melting almost everywhere. Scientists are also highly confident that temperatures in most permafrost regions have increased since the early 1980s, partly due to changing snow cover (IPCC-AR5-SPM). Likewise, Arctic sea ice shrank by 3.5 to 4.1 percent per decade from 1979 to 2012. In contrast, the extent of Antarctic sea ice increased by 1.2 to 1.8 percent per decade from 1979 to 2012 as more ice slipped from the continent into the water (IPCC-AR5-SPM).

As more ice melts, sea level rises. According to the IPCC, “Over the period 1901 to 2010, global mean sea level rose by 0.19 m on average,” faster than at any time in the past 2000 years (IPCC-AR5-SPM).

### 1.2.2 CAUSES OF CLIMATE CHANGE

The atmosphere lets light pass through to the surface, where objects absorb this energy, giving off heat radiation in the process. The atmosphere then partially traps this heat. Since the beginning of industrialization, anthropogenic greenhouse gases (GHGs) have significantly increased concentrations of carbon dioxide (CO<sub>2</sub>), methane (CH<sub>4</sub>) and nitrous oxide (N<sub>2</sub>O), to name the three most potent GHGs (IPCC-AR5-SPM). As a result, Earth's atmosphere is more effective at trapping heat.

Population growth is a major factor in carbon emissions from fossil fuel consumption, but the impact of this growth remained stable from 2000 to 2010 relative to the three previous decades. In contrast, the impact of economic growth has skyrocketed. In particular, greater coal consumption has begun to make the global carbon intensity of energy consumption higher once again after a brief period of progress (IPCC-AR5-SPM).

Since the IPCC's Fourth Assessment Report, scientists have collected even more evidence of man-made climate change. In fact, scientists now estimate that anthropomorphic impacts make up “more than half of the observed increase in global average surface temperature from 1951 to 2010” (IPCC-AR5-SPM). All continents except Antarctica are affected. Since 1960, anthropomorphic effects are likely to have affected the global water cycle, including the melting of glaciers and, since 1993, surface melting of the Greenland ice sheet. Likewise, civilization's emissions are very likely contributors to Arctic sea ice loss since 1979 and the global mean sea level rise observed since the 1970s.

### 1.2.3 IMPACTS OF CLIMATE CHANGE

Natural and human systems are sensitive to climate change, and impacts have been observed on all continents and in oceans (IPCC-AR5-SPM). Along with melting snow and ice, changes in precipitation are affecting both the quantity and quality of water resources. On land and in both fresh and saltwater, numerous species – plant and animal – have seen the location of their habitats shift, as have migration patterns.

Seasonal activities are also changing, and species are interacting differently in response to climate change. Ocean acidification also affects marine life.

You don't need to be a scientist to measure the changes. Humans are also witnessing the effects directly, with numerous studies showing that a wide range of crops in a large number of regions now produce smaller harvests (IPCC-AR5-SPM). The Inuit can feel the permafrost soften under their feet, leading built structures to collapse. Pacific Islanders have seen their freshwater supplies contaminated with saltwater and coastlines inundated as sea level rises. Numerous countries around the world increasingly experience extreme floods and droughts. The IPCC itself admits that “not all regional effects of climate change are known,” but all of these trends were predicted. If current predictions for the future hold true, as is likely, the future looks bleak.

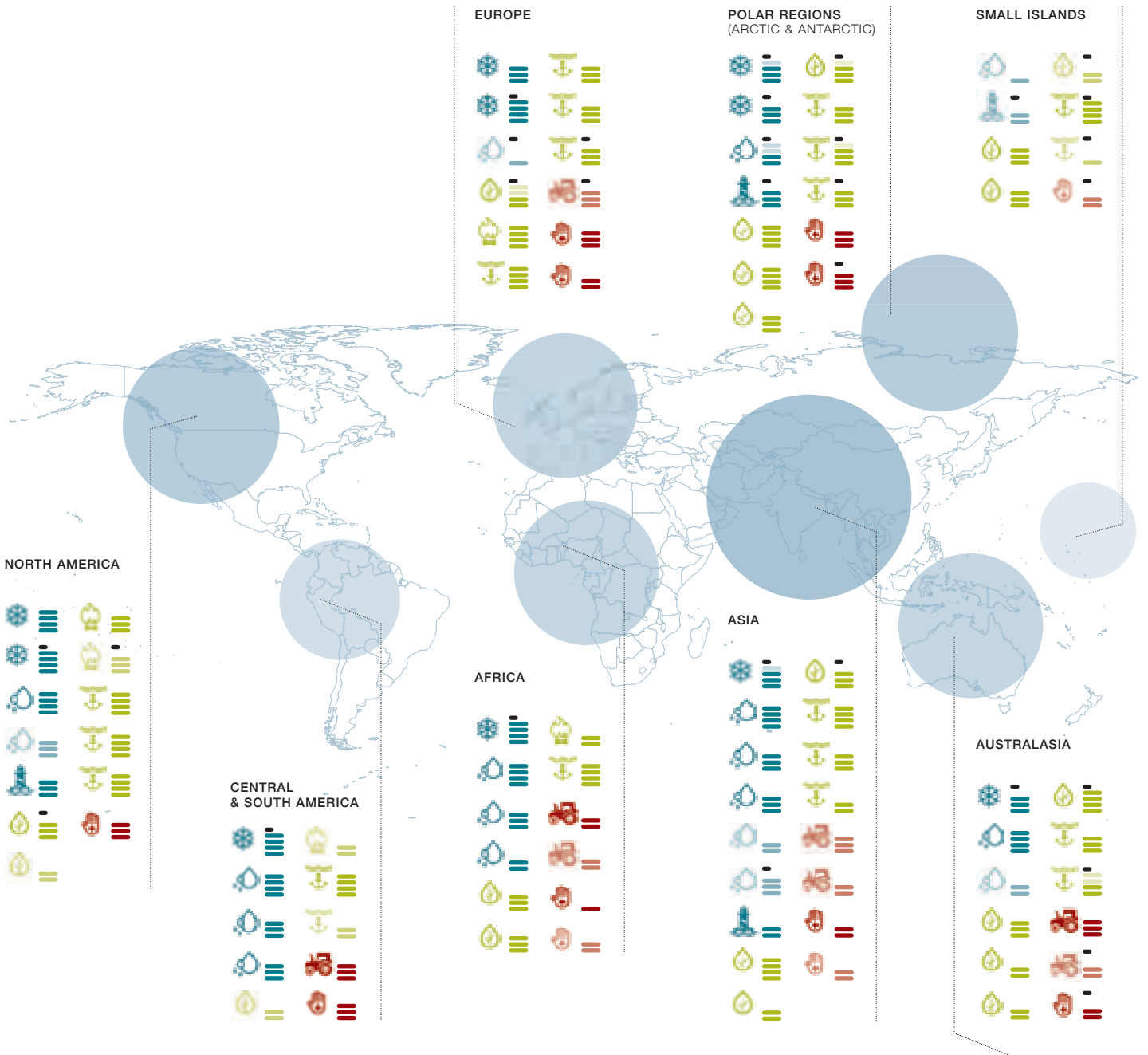
Sea level will continue to rise as glaciers melt, bringing landlocked ice into the oceans. In addition, the oceans themselves will thermally expand as the global temperature rises.

There will also be positive feedback – changes that amplify the trend. For instance, melting permafrost will release massive amounts of greenhouse gases. Less snow and ice cover will mean that more heat is absorbed by darker surfaces. Furthermore, numerous natural systems – coral reefs, mangroves, Arctic and Alpine ecosystems, boreal and tropical forests, prairie wetlands, and grasslands – will struggle to survive as the climate changes; if these natural systems shrink, they will not be able to trap as much carbon dioxide. Another result will be a greater risk of species extinction and lower biodiversity.

In Europe, rivers will increasingly flood, and the risk of floods, erosion, and wetland loss will increase in coastal areas everywhere. Industrialized countries have emitted the most GHGs, but developing countries – the ones least able to adapt to climate change – will be impacted the most. The areas hit the hardest include large parts of Africa, Asia, and the Pacific rim.

The long-term effects of global warming will be catastrophic. The Greenland ice sheet could melt completely, thereby eventually raising sea level up to seven meters. There is also new evidence that Antarctic ice is now at the risk of melting based on increased rates of ice discharge. As this freshwater enters the ocean, the Gulf Stream in the Atlantic could slow down or stop completely. The result would be a much different climate for Europe, which depends on the Gulf Stream to bring up warm air from the South. Furthermore, the Gulf Stream is part of a global system of ocean currents, which could also be disrupted, leading to unexpected shifts in climates around the globe. As the IPCC puts it, “Never before has humanity been forced to grapple with such an immense environmental crisis.”

**FIGURE 1.5 | WIDESPREAD IMPACTS ATTRIBUTED TO CLIMATE CHANGE BASED ON THE AVAILABLE SCIENTIFIC LITERATURE SINCE THE AR4**



**CONFIDENCE IN ATTRIBUTION TO CLIMATE CHANGE**  
 INDICATES CONFIDENCE RANGE  
 — VERY LOW    = LOW    = MED    = HIGH    = VERY HIGH

**PHYSICAL SYSTEMS**  
 ❄️ GLACIERS, SNOW, ICE AND/OR PERMAFROST  
 🌊 RIVERS, LAKES, FLOODS AND/OR DROUGHT  
 🏖️ COASTAL EROSION AND/OR SEA LEVEL EFFECTS

**BIOLOGICAL SYSTEMS**  
 🌿 TERRESTRIAL ECOSYSTEMS  
 🔥 WILDFIRE  
 🐟 MARINE ECOSYSTEMS

**HUMAN AND MANAGED SYSTEMS**  
 🏠 FOOD PRODUCTION  
 👤 LIVELIHOODS, HEALTH AND/OR ECONOMICS  
 — IMPACTS IDENTIFIED BASED ON AVAILABILITY OF STUDIES ACROSS A REGION

**note** The latest scientific research finds “substantially more impacts in recent decades now attributed to climate change.” Note that the chart above shows only those impacts for which causality has been demonstrated for climate change. Other impacts may be linked to global warming in the future, so the list could grow. **source** IPCC-AR5-SPM.

### 1.2.4 EXTREME EVENTS

Since 1950, some of the changes in extreme weather and climate events have been linked to human influences. Extremely cold temperatures have decreased, while extremely high temperatures have become more frequent. There is also been a noted increase in heavy precipitation in various regions. Heat waves have become more common in Europe, Asia, and Australia. The impacts of heat waves, droughts, floods, cyclones, and wildfires have revealed the “significant vulnerability and exposure of some ecosystems and many human systems to current climate variability” (IPCC-AR5-SPM).

If civilization continues to emit greenhouse gases, further warming is highly likely, with long-term, irreversible, and severe impacts on the entire climate. To prevent this calamity, greenhouse gas emissions need to be substantially reduced. Even then, significant resources will need to be devoted to future climate adaptation from current emissions (IPCC-AR5-SPM).



IMAGE SATELLITE IMAGE OF JAPAN'S DAI ICHI POWER PLANT SHOWING DAMAGE AFTER THE EARTHQUAKE AND TSUNAMI OF 2011.

### 1.3 NUCLEAR THREATS

Nuclear energy is a relatively minor industry with major problems. Currently covering just 2.3 per cent of the world's final energy consumption, nuclear's share is set to decline over the coming decades.

The amount of nuclear capacity added during last 15 years (2000-2014: 20,000 MW) (WNISR 2015)<sup>2</sup> was 17 times less than the new wind capacity built in the same period (356,000 MW) (REN21-2015).<sup>3</sup> Those new wind generators have a potential annual generation of 900 TWh – equal to 120 nuclear reactors with a capacity of 1000MW each.

Despite the rhetoric of a ‘nuclear renaissance’ – a term the nuclear industry has used since around 2001, the industry is struggling with massive cost increases, construction delays and safety and security problems. Japan's major nuclear accident at Fukushima following a tsunami came 25 years after the disastrous explosion in the Chernobyl nuclear power plant in the former Soviet Union, showing that nuclear energy is an inherently unsafe source of power. As a result, Siemens declared its exit from the nuclear power sector in 2011 and now only focuses on the delivery of spare parts for the existing reactors along with operation and maintenance service.

Following the Fukushima accident, the German Parliament resolved to shut all nuclear power plants by 2022,<sup>4</sup> including immediate the immediate closure of nearly half of them. That same year, Germany also passed a set of laws to further boost renewable energy and energy efficiency technologies. In the wake of the Fukushima accident, 95% of Italians also voted in a plebiscite to reject nuclear energy. At the start of 2012, over 90% of the Japan's reactors were offline. There have been no significant problems with the electricity supply with only 3 of 54 in operation.

#### REFERENCES

- 2 (WNISR 2015) WORLD NUCLEAR INDUSTRY STATUS REPORT 2015, MYCLE SCHNEIDER, ANTONY FROGGATT ET. AL.; PARIS / LONDON 2015.
- 3 (REN 21-2015); GLOBAL STATUS REPORT RENEWABLES 2015, REN 21; PARIS.
- 4 ATOMAUSSTIEGSGESSETZ – 30 JUNE 2011.

### 1.3.1 NO SOLUTION TO CLIMATE PROTECTION

The nuclear industry promises that nuclear energy can contribute to both climate protection and energy security; however, their claims need to be reality-checked.

The most recent World Energy Outlook 2015 and the Special Energy and Climate Report published by the International Energy Agency,<sup>5</sup> includes a Bridge scenario for a future energy mix to keep global carbon concentration below 450ppm. While renewables and energy efficiency play the largest role to achieve this target, a large expansion of nuclear power up to 2030 is still included. The technical assumption is that the installed capacity will be increased from 392 GW in 2013 up to 552 GW in 2030 – an additional 150 GW. To reach this goal, 10 GW – 7 to 10 nuclear reactors – need to come on line every year, an extremely unlikely given the “performance” of the nuclear industry. This pathway would be very expensive and hazardous, while hardly helping to reduce the emission of greenhouse gases. A more realistic analysis shows:

- The IEA scenario assumes investment costs of US\$ 4,800/kWe installed, in line with what the industry has been promising. The reality indicates costs of new plant are three to four times higher (see box).
- Massive expansion of nuclear energy comes with an increase in related hazards: the risk of serious reactor accidents like in Fukushima, Japan; the growing stockpiles of deadly high level radioactive waste which will need to be safeguarded for hundreds of thousands of years; and potential proliferation of both nuclear technologies and materials through diversion to military or terrorist use.
- Climate science says that we need to reach a peak of global greenhouse gas emissions before 2020. Even if the world's governments decided on strong nuclear expansion now, not a single new reactor would start generating electricity before 2020 because it typically takes at least ten years from decision to commissioning. Any significant contribution from nuclear power towards reducing emissions would come too late to help save the climate.

### 1.3.2 THE DANGERS OF NUCLEAR POWER

Electricity from nuclear power does produce less carbon dioxide than fossil fuels, but nuclear power poses multiple threats to people and the environment during operation. The main risks are for safety of the reaction, nuclear waste disposal and nuclear proliferation. These three risks are detailed below and are the reasons nuclear power has been discounted as a future technology in the Energy [R]evolution Scenario.

#### Safety risks

Several hundred accidents have occurred in the nuclear energy industry since it began, including Windscale (1957), Three Mile Island (1979), Chernobyl (1986), Tokaimura (1999) and Fukushima (2011). Despite the nuclear industry's assurances that a nuclear accident of the Chernobyl scale could never happen again, an earthquake and subsequent tsunami in Japan caused leaks and explosions in four reactors at the Daiichi nuclear power plant. Large areas around the plant have been seriously contaminated with radioactivity from the plant. Areas up to 50 km from the facility have been evacuated, and food and water restrictions apply at distances exceeding 100 km. The impacts on the lives of hundreds of thousands of people and on the Japanese economy will be felt for decades to come. The Fukushima disaster proves the inherent safety problems with nuclear energy.

- All existing nuclear reactors need continuous power to cool the reactors and the spent nuclear fuel, even after the reactor has shut down. In 2006, the emergency power systems failed at the Swedish Forsmark plant for 20 minutes during a power outage, and four of Sweden's ten nuclear power stations had to be shut down. If power had not been restored, there could have been a major incident within hours.
- A nuclear chain reaction must be kept under control, and harmful radiation must, as far as possible, be contained within the reactor, with radioactive products isolated from humans and carefully managed. Nuclear reactions generate high temperatures, and fluids used for cooling are often kept under pressure. Together with the intense radioactivity, these high temperatures and pressures make operating a reactor difficult and complex.
- The risks from operating reactors are increasing, and the likelihood of an accident is now higher than ever. Most of the world's reactors are more than 25 years old and therefore more prone to age-related failures. Many utilities are attempting to extend the life of their reactors, which were designed to last only 30 years, up to 60 years, which poses new risks.

#### REFERENCES

<sup>5</sup> (IEA-WEO-SR-2015) INTERNATIONAL ENERGY AGENCY; WORLD ENERGY OUTLOOK 2015 – SPECIAL REPORT ENERGY AND CLIMATE; JUNE 2015; PARIS/FRANCE.

- A series of institutional failures set the stage for the Fukushima Daiichi disaster including a system of industry-led self-regulation, the industry's overconfidence, its inherently dismissive attitude towards nuclear risks, and its neglect of scientific evidence. Institutional failures are the main cause of all past nuclear accidents, but the nuclear industry's risk assessments fail to take those into account.
- Nuclear utilities are reducing safety-related investments and have limited staff numbers, but they are increasing reactor pressure and operational temperature and the burn-up of the fuel. This accelerates ageing and decreases safety margins.

### Nuclear waste

Despite 50 years radioactive waste, there is no solution for the long-term storage and safeguarding of these dangerous materials. Disposal sites of low-level radioactive waste have already started leaking after only decades, even though highly radioactive waste needs to be safely contained for hundreds of thousands of years. The nuclear industry claims it can 'dispose' of its nuclear waste by burying it deep underground, but this approach will not isolate the radioactive material from the environment forever. A deep dump only slows down the release of radioactivity into the environment. Power plant developers try to predict how fast a dump will leak so that it can claim that radiation doses to the public living nearby in the future will be "acceptably low". But scientific understanding is not sufficiently advanced to make such predictions with any certainty.

As part of a campaign to build new nuclear stations around the world, the industry claims that public acceptability, not technical obstacles, is the main problem that burying radioactive waste faces. It cites nuclear dumping proposals in Finland and Sweden but without scientific backing for its claims of safe disposal.

The most hazardous waste is the spent fuel removed from nuclear reactors, which stays radioactive for hundreds of thousands of years. In some countries, the situation is exacerbated by 'reprocessing' this spent fuel, which involves dissolving it in nitric acid to separate out weapons-usable plutonium. This process leaves behind a highly radioactive liquid waste. There are about 270,000 tonnes of spent nuclear waste fuel in storage, much of it at reactor sites. Spent fuel is accumulating at around 12,000 tonnes per year, with around a quarter of that used for reprocessing.<sup>6</sup>

The least damaging option for waste already in existence is to store it above ground, in dry storage at the site of origin. However, this option also presents major challenges and threats, as was seen in the Fukushima accident where there was major disruption to the cooling of the spent nuclear fuel. The only real solution is to stop producing the waste.

### Nuclear proliferation

Manufacturing a nuclear bomb requires fissile material - either uranium-235 or plutonium-239. Most nuclear reactors use uranium as a fuel and produce plutonium during operation. It is impossible to adequately prevent the diversion of plutonium to nuclear weapons. A small-scale plutonium separation plant can be built in four to six months, so any country with an ordinary reactor can produce nuclear weapons relatively quickly.

As a result, nuclear power and nuclear weapons have grown up like Siamese twins. Since international controls on nuclear proliferation began, Israel, India, Pakistan and North Korea have all obtained nuclear weapons; aside from Israel and North Korea, all of these countries also have nuclear power plants. The tasks of International Atomic Energy Agency (IAEA) and the Nuclear Non-proliferation Treaty (NPT) are inherently contradictory: to promote the development of 'peaceful' nuclear power whilst at the same time trying to stop the spread of nuclear weapons.

Israel, India and Pakistan all used their civil nuclear operations to develop weapons capability, operating outside international safeguards. North Korea developed a nuclear weapon even as a signatory of the NPT. A major challenge to nuclear proliferation controls has been the spread of uranium enrichment technology to Iran, Libya and North Korea. The former Director General of the International Atomic Energy Agency, Mohamed ElBaradei, has said that "should a state with a fully developed fuel-cycle capability decide, for whatever reason, to break away from its non-proliferation commitments, most experts believe it could produce a nuclear weapon within a matter of months".<sup>7</sup>

The United Nations Intergovernmental Panel on Climate Change has also warned that the security threat of trying to tackle climate change with a global fast-breeder programme (using plutonium fuel) "would be colossal".<sup>8</sup> All of the reactor designs currently being promoted around the world could be fuelled partly with MOX (mixed oxide fuel), from which plutonium can be easily separated.

Restricting the production of fissile material to a few 'trusted' countries will not work. Instead, it would create greater security threats through inequity and resentment. A new UN agency is needed to tackle the twin threats of climate change and nuclear proliferation by phasing out nuclear power and promoting sustainable energy, which would promote world peace rather than threaten it.

### REFERENCES

- <sup>6</sup> 'WASTE MANAGEMENT IN THE NUCLEAR FUEL CYCLE', WORLD NUCLEAR ASSOCIATION, INFORMATION AND ISSUE BRIEF, FEBRUARY 2006 (WWW.WORLD-NUCLEAR.ORG/INFO/INF04.HTM).
- <sup>7</sup> MOHAMED ELBARADEI, 'TOWARDS A SAFER WORLD', ECONOMIST, 18 OCTOBER 2003.
- <sup>8</sup> IPCC WORKING GROUP II, 'IMPACTS, ADAPTATIONS AND MITIGATION OF CLIMATE CHANGE: SCIENTIFIC-TECHNICAL ANALYSES', 1995.



# CLIMATE AND ENERGY POLICY

INTERNATIONAL CLIMATE POLICY -  
THE UNFCCC AND THE KYOTO  
PROTOCOL

RENEWABLE ENERGY POLICIES

POLICY RECOMMENDATIONS



“  
win-win-strategy:  
reducing carbon  
emissions with  
renewables”

**IMAGE** NINE MILLION CADMIUM TELLURIDE SOLAR MODULES NOW COVER PART OF CARRIZO PLAIN IN SOUTHERN CALIFORNIA. THE MODULES ARE PART OF TOPAZ SOLAR FARM, ONE OF THE LARGEST PHOTOVOLTAIC POWER PLANTS IN THE WORLD. AT 9.5 SQUARE MILES (25.6 SQUARE KILOMETERS), THE FACILITY IS ABOUT ONE-THIRD THE SIZE OF MANHATTAN ISLAND, OR THE EQUIVALENT OF 4,600 FOOTBALL FIELDS. WHEN OPERATING AT FULL CAPACITY, THE 550-MEGAWATT PLANT PRODUCES ENOUGH ELECTRICITY TO POWER ABOUT 180,000 HOMES. THAT IS ENOUGH TO DISPLACE ABOUT 407,000 METRIC TONNES OF CARBON DIOXIDE PER YEAR, THE EQUIVALENT OF TAKING 77,000 CARS OFF THE ROAD.

© NASA LANDSAT

To make the Energy [R]evolution a reality, immediate political action is required. There are no economic or technical barriers to move to 100% renewable energy. Governments regulate energy markets, both for supply and demand; they can educate everyone from consumers to industrialists and stimulate the market for renewable energy and energy efficiency by implementing a wide range of economic mechanisms. They can also build on the successful policies already adopted by other countries. To get started, governments need to agree on further binding emission reduction commitments under the UNFCCC process.

## 2.1 INTERNATIONAL CLIMATE POLICY - THE UNFCCC AND THE KYOTO PROTOCOL

Recognising the global threats of climate change, the signatories to the 1992 UN Framework Convention on Climate Change (UNFCCC) followed up with the Kyoto Protocol in 1997. It entered into force in early 2005, and its 193 members meet continuously to negotiate further refinement and development of the agreement. Only one major industrialised nation, the United States, has not ratified the protocol. In 2011, Canada announced its intention to withdraw from the Protocol.

In Copenhagen in 2009, the 195 members of the UNFCCC were supposed to deliver a new climate change agreement towards ambitious and fair emission reductions. Unfortunately, they failed at this conference.

At the 2012 Conference of the Parties in Durban, there was agreement to reach a new agreement by 2015 and adopt a second commitment period at the end of 2012.

During the 2014 conference in Lima, the US and other developed countries emphasised the need to be “realistic” and “nationally determined” with future emission cuts, and resisted stronger action on finance and adaptation, in particular for the most vulnerable countries. India and China, on the other hand, allied with oil-producing states in an effort to protect themselves from taking on tougher and more binding emissions cuts in the future. The result was a messy compromise that sets no common time frame for future pollution cuts. While the Lima decision does require countries to submit basic information about the climate actions they plan to include in the next conference agreement (Paris - COP21 in 2015), it also downgrades the proposed assessment of the fairness and adequacy of countries’ contributions partly as a result of pressure from China and India. Instead, the secretariat is to compile a mere technical paper assessing the aggregate effect of the targets.

The outcome in Lima established no clear requirement for rich countries to include climate finance in their reported actions before Paris, nor does it establish a clear road-map for scaling up finance towards the 100 billion dollars a year promised by 2020. However, over time it does put adaptation on a more equal footing with emission reductions.

In December 2015, the global community will meet in Paris for the 21st UN Conference of the Parties (COP21) to negotiate and sign a new global agreement to address dangerous global warming. The success of the Paris COP hinges upon countries agreeing to support a vision for 100% clean renewable energy by 2050 and increased forest protection. The formal negotiating text was released in March 2015 and further negotiated in Bonn from 1-11 June 2015.

Meanwhile, the global emissions landscape is changing rapidly. As a result of declining coal consumption in China, global energy-related CO<sub>2</sub> emissions remained stable in 2014 for the first time in 40 years, despite continued economic growth. If global mitigation endeavours are strengthened, this trend is set to continue. This new landscape provides a greater chance that the coal, oil and nuclear industries – which continue to fight to maintain their dominance by propagating the outdated notion that citizens need their dirty energy – will face dramatic changes in both energy markets and support from governments.

**Countries’ commitments** Countries’ national commitments (also known as *intended nationally determined contributions - INDCs*) are key components of the Paris agreement as they are the tools for immediate and drastic emissions cuts. Parties were asked to submit their proposed mitigation commitments well in advance of the Paris conference. Thus far, several major emitters, including China, have already presented their plans. It is crucial that the remaining countries submit as soon as possible.

**International climate policy - looking ahead** Countries should not only present their short-term commitments, based on 5-year periods, but also outline long-term plans for a just transition to an economy built on 100% clean renewable energy. Countries should include other policy commitments in their INDCs, such as renewable energy and energy efficiency targets along with commitments to stop fossil fuel subsidies. Rich countries and other countries in a position to do so should also address the question of climate finance in their commitments to ensure predictability and adequacy for vulnerable countries.

**An effective climate** agreement should include strong short-term action and set out a clear long-term pathway. Key elements include the following:

- A strong long-term goal: Phase-out of fossil fuels and nuclear power by 2050 through a just transition towards 100% renewable energy, as well as the protection and restoration of forests. A clear signal to decision-makers and investors at all levels that the world is moving towards phasing out carbon emissions entirely and accelerating the transition to 100% renewable energy is needed. Countries’ short-term emission reduction commitments must align with this long-term goal and support transformational change, ensuring both fairness and solidarity.

- **A 5-year cycle process for country commitments starting 2020**  
All countries' commitments should follow a **5-year commitment period** starting in 2020, which would form the first period of the Paris Protocol. Moving forward, each period would further deepen the commitments, allowing no back-sliding. 5-year commitment periods incentivize early action, allow for dynamic political responses and avoid locking in low levels of ambition. They allow for a timely adaptation to the technological advances of renewable energies and energy efficiency.
- **Legally binding:** A legally binding protocol - including common accounting rules for mitigation and finance - will compel leaders to act in a strong way; legally binding obligations are the real expressions of political will, ensuring durability in the face of political changes and increased ambition over time.
- **Shifting subsidies away from fossil fuels.** All countries should commit to phase-out all subsidies- both production and consumption - for fossil fuels until 2020 subsidies.
- **Strong commitment for adaptation, finance and loss and damage:** The Paris Protocol should acknowledge that less mitigation action means a greater need for adaptation, especially finance. Consequently, an adaptation goal should be established to ensure that the level of support meets vulnerable countries' needs under the actual warming anticipated. A roadmap must be decided in Paris for how to meet the 100bn USD commitment for climate financing by 2020.
- **Bring down emissions before 2020.** The gap between the agreed upon goal of keeping warming below 2°C/1.5°C and what countries actually intend to do by 2020 is widely acknowledged. The pledges during time of writing of this report (mid-2015) would lead us into a world of 3 or more degrees warming, with all its devastating consequences for humans and ecosystems. While a process on how to bring the emissions down was established at COP17 in 2011, countries are still – four years later – failing to agree upon sufficient action to mitigate greenhouse gases. In Paris at the latest, governments and corporate leaders need to provide innovative solutions for breaking the stalemate and laying the groundwork for bold actions before 2020.

### 2.1.1 INTERNATIONAL ENERGY POLICY - ENERGY POLICY AND MARKET REGULATION

On many energy markets, renewable energy generators currently compete with old nuclear and fossil fuel power stations on an uneven playing field. Consumers and taxpayers have already paid the interest and depreciation on the original investments, so the generators are running at a marginal cost. Political action is needed to overcome market distortions so renewable energy technologies can compete on their own merits.

While governments around the world are liberalising their electricity markets, the increasing competitiveness of renewable energy should lead to higher demand. Without political support, however, renewable energy remains at a disadvantage, marginalised after decades of massive financial, political and structural support for conventional technologies. Developing renewables will therefore require strong political and economic efforts, for example through laws that guarantee stable payment for up to 20 years. Renewable energy will also contribute to sustainable economic growth, high quality jobs, technology development, global competitiveness, and industrial and research leadership.

### 2.2 RENEWABLE ENERGY POLICIES

In 2014, the global market trended towards increased levels of renewable energy, with variable generation from wind and solar leading the way. More electricity was used as a result, replacing fuels both for heating and transport and changing energy markets significantly, particularly in developed countries.

Global subsidies for fossil fuels and nuclear power remain high despite reform efforts. Creating a level playing field can lead to a more efficient allocation of financial resources, helping to strengthen initiatives for the development and implementation of energy efficiency and renewable energy technologies. Removing fossil-fuel and nuclear subsidies globally would more accurately reflect the true cost of energy generation.

Cost competitiveness per unit no longer remains a barrier; however, grid-connected renewable energy power plants and the secure transport and delivery of electricity represent an increased investment risk because it leads to uncertainty for overall electricity sales from RE plants. In 2014, there was a growing trend to link several policies together (such as renewable energy targets, feed-in tariffs or tendering, and grid access). The movement towards 100% renewable energy targets for regions, islands, large cities and whole countries continued to grow over the course of 2014. The following section about the status of renewable energy policies by the end of 2014 is based on an analysis published by the Renewable Energy Network for the 21st Century (REN21) (REN21 – 2015).<sup>1</sup>

#### REFERENCES

<sup>1</sup> REN21 – RENEWABLES 2015 – GLOBAL STATUS REPORT; JUNE 2015, PARIS / FRANCE.

### 2.2.1 STATUS OF RENEWABLE ENERGY POLICIES FOR ELECTRICITY

Targets and supporting policy tools to promote renewable energy for power generation continued to receive the majority of attention from policymakers, outpacing those set for the heating, cooling, and transportation sectors.

- **Targets** have been identified in 164 countries as of early 2015 and were added or revised in 11 countries in 2014.
- **Feed-in tariffs (FITs)** have now been enacted in 108 jurisdictions at the national or state/provincial level. Egypt was the only country adding a new national FIT in 2014, but a number of existing policies were amended with changes varying by region, continuing the trend in recent years. Countries including Bulgaria, Germany, Greece, Italy, Japan, Russia, Switzerland, and the Philippines reduced rates, while rates were increased and/or eligibility was expanded in Algeria, Denmark, Malaysia, Poland, and Vietnam. China enacted a slate of revisions, simultaneously opening FITs to new technologies and reducing rates for some previously covered technologies.
- **Tendering** both technology-neutral and technology-specific tendering continues to be adopted by a growing number of countries, with 60 countries having utilized renewable energy tenders as of early 2015. The European Commission issued guidelines to begin a continent-wide shift away from FITs towards tenders. Poland indicated its intention to phase out its green certificate scheme in favor of tenders.
- **New net-metering policies** were added in three countries, all in Latin America.
- **Renewable Portfolio Standards (RPS)** policies continue to face opposition in a number of US States. In 2014, Ohio became the first state to freeze its RPS, and in 2015 West Virginia became the first state to remove its (voluntary) RPS entirely. An estimated 126 countries had adopted some form of financial support policy to promote renewable energy technologies by early 2015.
- **Barriers to renewable energy:** Charges or fees on renewable energy have been introduced in an increasing number of countries. In Europe, Germany, Austria and Italy enacted new charges on self-consumed solar PV, joining fellow EU member states including the Czech Republic, Greece, and Spain with fees and/or taxes on renewable energy output.

### 2.2.2 STATUS OF RENEWABLE ENERGY POLICIES FOR HEATING AND COOLING

Policies for renewable heating and cooling are slowly gaining more attention from national policymakers. An estimated 45 countries worldwide had targets for renewable heating or cooling in place by early 2015. In Europe, the majority of targets in EU and Energy Community Member States have been introduced through each country's National Renewable

Energy Action Plan (NREAP), while other countries have adopted technology specific targets focused on specified capacity or new installations of renewable heating systems.

- **Solar-specific renewable heat mandates** were in place in 12 countries at the national or state/provincial level, and technology-neutral mandates were in place in an additional 9 countries by early 2015. South Africa was the only country to institute a new mandate during 2014.
- **Financial incentives** continued to be the most widely enacted form of policy support for renewable heating and cooling systems in 2014. Algeria, Chile, Romania, and Slovenia all re-introduced incentive schemes that had expired in previous years, the Czech Republic, India, and Kenya strengthened existing schemes, and the US states of Minnesota and New York established new rebate programs in 2014.

### 2.2.3 RENEWABLE ENERGY TRANSPORT POLICIES

The majority of transport-related policies continued to focus on developments in the biofuel sector and road transport; however, other modes of transportation are attracting attention as well. Policies promoting the linkage between electric vehicles and renewable energy have received little attention to date.

The debate over the sustainability of first-generation biofuels continued worldwide in 2014, with European energy ministers agreeing to a 7% cap on the contribution of first-generation biofuel to meet the EU-wide 10% renewable transport fuel target. Italy became the first country in Europe to enact a mandate promoting a specific share (0.6% by 2018) of second-generation biofuels.

Biofuel blend mandates are now in place in 34 countries, with 32 national mandates and 26 state/provincial mandates. Within these policy frameworks, 45 jurisdictions now mandate specified shares of bioethanol, and 27 mandate biodiesel blends, with many countries enacting both. Argentina, Brazil, Malaysia, Panama, Vietnam, and the US state of Minnesota all strengthened existing blend mandates in 2014.

### 2.2.4 CITY AND LOCAL GOVERNMENT RENEWABLE ENERGY POLICIES

Cities continue to set and reach ambitious targets for renewable energy use which are also influenced by regions and countries with 100% renewable energy targets. Joining a growing global movement of cities, new 100% targets were set in Fukushima (Japan) and Maui County, Hawaii (USA). Burlington, Vermont (USA), reached its 100% renewable electricity goal in 2014.

Municipal policymakers in countries including Brazil, China, India, and the United Arab Emirates continued a growing trend of utilizing municipal oversight of build code regulations

to mandate the deployment of renewable power generation and renewable heat technologies.

Public-private partnerships and community power systems are increasingly being utilized to increase renewable energy at the local level. In the United States, over 2,000 communities have already created community power systems. An additional 800 have created electricity co-operatives to increase local control over power generation, while the CO-POWER project was inaugurated in Europe to support community power development across 12 European countries.

District heating and cooling systems have emerged as an important measure, helping to facilitate the scale-up of renewable energy, with Dubai (UAE) and Paris (France) leading in 2014. In Europe, primarily in northern countries such as Denmark, large-scale solar thermal heating plants are increasingly being developed for connections to district heat networks.

Municipal policymakers continued to use their purchasing authority to support renewable energy in their cities. Cities such as Paris (France) and San Francisco (USA) purchased electric and biofuel vehicles for city fleets, including buses used in public transportation systems.

### 2.2.5 DISTRIBUTED RENEWABLE ENERGY IN DEVELOPING COUNTRIES

More than one billion people or 15% of the global population still lack access to a power grid. With a total installed capacity of roughly 147 GW, all of Africa has less power generation capacity than Germany. Moreover, approximately 2.9 billion people lack access to cleaner forms of cooking.

Energy companies invested about USD 63.9 billion in off-grid solar PV in 2014. Bank of America (USA) pledged USD 1 billion to help finance distributed renewable energy projects that normally would not pass risk assessments. It also agreed to seed a Catalytic Finance Initiative to stimulate at least USD 10 billion of new investment in high-impact clean energy projects. The aim is for such initiatives to help develop innovative financing mechanisms, reduce investment risk and attract a broader range of institutional investors to the sector.

There were new initiatives related to clean cooking during 2014. In July, Ecuador started executing a plan to introduce 3 million solar induction cooktops by 2016. Guatemala established a Cluster of Improved Cook Stoves and Clean Fuels, representing individuals and organizations who work in these two areas. Bangladesh announced a Country Action Plan for Clean Cook Stoves. India launched the Unnat Chulha Abhiyan Programme to develop and deploy 2.75 million clean stoves by 2017. Several African countries, including Nigeria and Senegal, also have programs to distribute millions of clean cook stoves.

Some 30 transnational programs and 20 global networks support national distributed renewable energy programs. The

Sustainable Energy for All Initiative (SE4ALL), Power Africa program, the Energizing Development Program, the Global Alliance for Clean Cook Stoves, and the Global Lighting and Energy Access Partnership are playing a key role in further distribution of distributed renewable energy, especially in least developed countries.

In addition to existing, well established technologies such as solar home systems and micro hydro dams, 2014 witnessed the evolution of new types of equipment, configurations, and applications. Thermoelectric generator (TEG) stoves utilize their own heat to produce power that operates the blower or fan, eliminating the need for an external source of electricity and increasing the efficiency of combustion. Flexi-biogas systems use balloon (or tube) digesters made from a polyethylene or plastic bag, making them mobile and extremely lightweight. Pico-wind turbines offer a very low-cost technology for powering remote telecommunications. Solar-powered irrigation kits enable farmers to grow high-value fruits and vegetables.

Ancillary services and monitoring are making use of digitization, and the “internet of things” facilitates improved after-sales, better customer service, and lower costs, enabling companies to reach more customers. Solar direct current (DC) micro-grids offer superior compatibility with certain electric appliances and can eliminate the need for an inverter. Bundling of products and services together into hybridized or integrated packaged systems— especially bundles that promote electricity and appliance usage, telecommunications, and/or cooking—are a high-impact innovation.

### 2.2.6 ENERGY EFFICIENCY: RENEWABLE ENERGY'S TWIN PILLAR

**Success stories for energy efficiency standards** Efficiency standards proved very successful in 2014. Building standards and the construction of passive houses were implemented, as were standards for electrical appliances in several developing and emerging economies. The focus has been on efficiency improvements in road transport, including fuel economy improvements in private vehicles, increased penetration of electric (EV) and hybrid (HEV) vehicles, and shifts to more sustainable modes of travel.

In 2013, more than 150 cities around the world had implemented some kind of building efficiency standard. By 2014, 81 countries had introduced energy standards and labeling programs, as well as mandatory energy performance standards covering 55 product types, with refrigerators, room air conditioners, lighting, and televisions being the most commonly regulated.

By the end of 2013, standards for electric motors used in industrial applications had been introduced in 44 countries, including Brazil, China, South Korea, and the United States. As of late 2014, vehicle fuel economy standards covered 70% of the world's light-duty vehicle market.

### 2.3 POLICY RECOMMENDATIONS

Countries around the world are at varying levels of development with RE. While some are just starting to deploy modern RE - beyond traditional biomass and hydro – others have already reached high penetration levels, particular for solar and wind in the electricity sector. Globally, policies have largely driven the expansion of renewable energy. The number of countries promoting renewables through direct policy support continued to grow in 2014, albeit at varying rates and in response to diverse drivers. As circumstances change and level of RE increases, the policy mechanisms required will change as well. While grid integration issues due to ever increasing shares of wind and solar PV are most pressing in developed countries, access to technology and financial resources is the highest priority in developing countries.

Policy frameworks must be stable and predictable in order to underpin the sustained deployment of renewable energy. The industry needs predictable policy frameworks in order to be ready to invest, build up production capacities, develop new technologies and expand skilled employees. Moreover, there is a close correlation between supporting policies and the cost of renewable energy technology.

Price support mechanisms for renewable energy are a practical way to correct market failures in the electricity sector. They aim to support market penetration of those renewable energy technologies, such as wind and solar thermal, that currently suffer from unfair competition due to direct and indirect support to fossil fuel use and nuclear energy, and to provide incentives for technology improvements and cost reductions so that technologies such as PV, wave and tidal can compete with conventional sources in the future.

Overall, there are two types of incentive to promote the deployment of renewable energy. These are Fixed Price Systems and Renewable Quota Systems (referred to in the US as Renewable Portfolio Standards). In the former, the government sets the price (or premium) paid to the power producer and lets the market determine the quantity; in the latter, the government sets the quantity of renewable electricity and leaves it to the market to determine the price. Both systems create a protected market against a background of subsidised, depreciated conventional generators whose external environmental costs are not accounted for. These policies provide incentives for technology improvements and cost reductions, leading to cheaper renewables that will be able to compete with conventional sources in the future.

The main difference between quota-based and price-based systems is that the former tends to promote the renewable energy source that is the cheapest, which is generally

onshore wind power. In doing so, this policy thus gives the most support to the energy source that needs the least. In contrast, price-based policies spread support across numerous renewable energy sources more equally, including those that are currently more expensive and need greater support. In doing so, they ramp up fledgling industries to bring costs down.

However, competition between technology manufacturers is the most crucial factor in bringing down electricity production costs. Only if large volumes of equipment can be manufactured, cost reduction potential can be fully exploited. So the goal of fighter policy should be large-scale deployment towards bringing about economies of scale among manufacturers.

A bankable support scheme for renewable energy projects provide long-term stability and lead to lower “soft costs” (less red tape). In any case, renewable power generation requires priority access and dispatch on the power grid so renewables are not curtailed in favour of more polluting power sources.

The substantial cost reductions of renewables are largely the result of policy support, which has attracted significant investments leading to economies of scale. However, abrupt policy change of policies, such as a sudden reversal of feed-in tariffs, can have major negative impacts for the industry as a whole. Therefore, any transition towards a new policy system requires sufficient time, both in the lead-up to implementation and in duration of the new policy itself so that industry can adapt its business model.

Today, the penetration of renewables is no longer a question of technology or economics but one of developing more flexible markets, smarter energy systems and – especially for developing countries – access to finance. This policy shift must be underpinned by the appropriate regulations, business, and finance models.

#### **100% renewables: aiming high to drive the transition**

High targets for renewable energy – across all sectors – trigger innovation. A complete transition towards renewable energy requires the development of new policies to support business models in an ever changing energy market design. Setting ambitious long-term renewable energy targets will help to organize the energy transition across all three sectors. Thus new policies are needed to restructure the electric power and heating markets, and to develop regulations to provide a fair and efficient basis for blending centralized and distributed generation with demand-flexibility measures. Our thinking about future energy systems needs to focus on how existing infrastructure must be adapted and enhanced to accommodate the ongoing integration of large shares of renewable energy.

### **Harnessing local action to ensure global renewable energy uptake**

Today, local governments are leaders in the advancement of renewable energy, particularly in combination with energy efficiency improvements. They regularly exceed efforts made by state, provincial, and national governments. Motivated to create local jobs, reduce energy costs, address pollution issues, and advance their sustainability goals, hundreds of local governments worldwide have set renewable energy targets and enacted fiscal incentives or other policies to foster the deployment of renewables. Governments at the community, city, regional, island, and even country levels have begun to forge their own transition pathways towards a 100% renewable energy future. A better linking of local renewable energy developments with those at the national level will be key to driving the energy transition.

### **Creating a level playing field for the entire energy sector**

Global subsidies for fossil fuels and nuclear power remain high despite reform efforts. The exact level of subsidies is unknown; estimates range from USD 544 billion (World Bank) to USD 1.9 trillion per year (International Monetary Fund), depending on how “subsidy” is defined. Whichever number is chosen, subsidies for fossil fuels and nuclear power are significantly higher than financial support for renewables. Electricity price subsidies for consumers in developing countries should be shifted towards Distributed Renewable Energy (DRE). Creating a level playing field can lead to a more efficient allocation of financial resources, helping to strengthen initiatives for the development and implementation of energy efficiency and renewable energy technologies. Removing fossil-fuel and nuclear subsidies globally would reflect more accurately the true cost of energy generation.

### **Improving energy data to monitor advancements in achieving a renewable energy transition**

Reliable, timely, and regularly updated data on renewable energy are essential for establishing energy plans, defining targets, designing and continuously evaluating policy measures, and attracting investment. The data situation for renewable energy – especially in the power sector - has improved significantly in recent years. Better record-keeping, accessibility, and advances in communication and collection methods have contributed greatly to this development. Nonetheless, the availability, accessibility, and quality of data for distributed renewable energy and bioenergy is still poor.

To overcome some of these existing data gaps, it is essential to develop innovative and collaborative approaches to data collection, processing, and validation. Until recently, “acceptable data” have been limited to official statistics (formal data). For an accurate and timely understanding of the status of the renewable energy sector, official renewable energy data need to be supplemented with informal data.

The addition of informal data can improve coverage of sectors and regions and help resolve the lack of data; however, previously uninvolved players from varying sectors would then need to be involved. Many of these individual and institutional actors typically have already engaged in some form of data collection but are unaware of the importance of their data or lack the means of sharing them. Additionally, cross-sector methods and approaches for data collection must be considered. By utilizing links between energy and other sectors, such as health and agriculture, data gaps can be filled and data quality improved. There is a critical need to broaden the definition of renewable energy data, to collect data in a regular and more systematic manner, and to increase transparency.

### **Renewable power: (energy) system thinking required in developed countries**

With increased shares of variable solar and wind power generation, a variety of technologies need to be integrated in one resilient power supply system. Thus, policy developments should shift away from single-technology support schemes towards ones that support a combination of diverse technologies. Policies need to transform power grids to become more flexible, increase demand-side integration, and integrate power systems with transport, buildings, industry, and heating and cooling sectors.

Utilities and grid operators will also play an important role in managing demand and generation in renewable energy-dominated energy systems. Demand-side management of industries, transport systems and households and the operation of distributed generation fleets require different energy policies to enable new business models. Achieving a renewable energy technology mix which can be used for dispatching - also across the power, heating/cooling and transport sector - is important.

Heating systems, such as heat pumps or district heating networks can be used to better integrate solar and wind power. The German “Energiewende” (German for “energy transition”) has inspired many countries, helping to build new momentum around renewable energy. Experiences with system integration in industrialized countries such as Spain, Germany, Denmark and the US can help develop future concepts for developing countries to help establish trust that energy supply can fundamentally build on RE.

### **The renewable heating and cooling sector lacks progress**

To achieve the transition towards renewable energy, more attention needs to be paid to the heating and cooling sectors, as well as to integrated approaches that facilitate the use of renewables in this sector. Globally, heating and cooling accounts for almost half of total global energy demand. However, this sector continues to lag far behind the

renewable power sector when it comes to policies that support technology development and deployment. Policies should make sure that specific targets and appropriate measures to support renewable heating and cooling are part of any national renewable energy strategy. They should include financial incentives; awareness-raising campaigns; training for installers, architects and heating engineers; and demonstration projects.

For new buildings and those undergoing major renovation, a minimum share of heat consumption from renewable energy should be required, as is already implemented in some countries. At the same time, increased R&D efforts should be undertaken, particularly in the fields of heat storage and renewable cooling. Mandatory regulations in the building sector can also help increase the penetration of renewable technologies. Improving the accuracy of national data collection on heating and cooling supply and demand is also important. The distributed nature of heat supply and local demand make it difficult to know what sources are available and what is needed; this information is crucial for good policy development. The expansion of district heating networks supports both the development of renewable energy heating and benefits the integration of variable power generation. Heating networks can be utilized for demand side management, relieving pressure on power grids. A smart combination of heating and power grids can also reduce the need for grid expansion, decreasing costs further.

#### **Getting the policy mix right in developing countries**

In developing countries, access to financial resources, technology, and information is key. Many developing countries also have a steep energy demand, particularly in the industrial sector. Ensuring the energy supply for heavy industries and for small and medium enterprises is crucial for the economic development of these countries. With renewable energy – modular and highly standardized power technologies – expanding energy supply for all consumer groups is not a technological, but a political challenge. Access to expertise and financial resources requires stable, long-term energy policies.

There is also an urgent need to address the lack of access to energy services and inefficiencies in the provision of energy services to the urban poor and rural communities. Improved energy access is crucial towards advancing the quality of life and socio-economic status of these populations, in turn contributing to political stability on national, regional and international levels and helping to improve economic growth and environmental sustainability. Renewables have a key role to play in increasing access through distributed solutions.

Stand-alone cooking and electricity systems based on renewables are often the most cost-effective options available for providing energy services to households and businesses in remote areas. Supporting the development of distributed renewable energy-based systems to expand energy access is essential. Combined with information and communication technology (ICT) applications for power management and end-user services, recent technical advances that enable the integration of renewables in mini-grid systems allow for rapid growth in the use of mini-grids powered with renewables.

There is growing awareness that off-grid, low-income customers can provide fast-growing markets for goods and services. The emergence of new business and financing models to serve them means that these energy markets are increasingly recognized as offering potential business opportunities. Despite some progress on expanding energy access in different parts of the world, some 1.3 billion people still lack access to electricity, and more than 2.6 billion people rely on traditional biomass for cooking and heating, with the related negative health impacts. In order to support the expansion of energy markets to reach full energy access – as promoted by SE4ALL – the public and private sector need to actively work together to ensure the financing of distributed renewable energy by developing and implementing support policies, establishing broader legal frameworks, and ensuring political stability.

#### **Efficiency: Set stringent efficiency and emissions standards for appliances, buildings, power plants and vehicles**

Policies and measures to promote energy efficiency exist in many countries. Energy and information labels, mandatory minimum energy performance standards and voluntary efficiency agreements are the most popular measures. Effective government policies usually contain two elements – those that use standards to push the market and those that use incentives to pull. Both are an effective, low cost way to transition to greater energy efficiency.

The Japanese front-runner programme, for example, is a regulatory scheme with mandatory targets which gives incentives to manufacturers and importers of energy-consuming equipment to continuously improve the efficiency of their products. It operates by allowing today's best models on the market to set the level for future standards.



### Support innovation in energy efficiency, low carbon transport systems and renewable energy production

Innovation will play an important role in the Energy [R]evolution, and it is needed for ever-improving efficiency and emissions standards. Programmes supporting renewable energy and energy efficiency are a traditional focus of energy and environmental policies because energy innovations face barriers all along the energy supply chain (from R&D to demonstration projects and widespread deployment). Direct government support through a variety of fiscal instruments, such as tax incentives, is vital to hasten deployment of radically new technologies that face a lack of industry investment. There is thus a role for the public sector towards increasing investments directly and in correcting market and regulatory obstacles that inhibit investment in new technology.

Governments need to invest in research and development for more efficient appliances and building techniques, new forms of insulation, new types of renewable energy production (such as tidal and wave power), and a low-carbon transport future, such as the development of better batteries for plug-in electric cars and renewable fuels for aviation. Governments need to engage in innovation themselves, both through publicly funded research and by supporting private research and development.

There are numerous ways to support innovation. The most important policies are those that reduce the cost of research and development, such as tax incentives, staff subsidies and project grants. Financial support for research and development on 'dead end' energy solutions such as nuclear fusion should be diverted to supporting renewable energy, energy efficiency and distributed energy solutions.

### Transport

- **Emissions standards:** Governments should regulate the efficiency of private cars and other transport vehicles in order to push manufacturers to reduce emissions through downsizing, design and technology improvement. Improvements in efficiency will reduce CO<sub>2</sub> emissions irrespective of the fuel used. Afterwards, further reductions could be achieved with low-emission fuels. Emissions standards should provide for a mandatory average reduction of 5g CO<sub>2</sub>/km/year in industrialised countries. To dissuade car makers from overpowering high-end cars, a maximum CO<sub>2</sub> emissions limit for individual car models should be introduced.

- **Electric vehicles:** Governments should develop incentives to promote the further development of electric cars and other efficient and sustainable low-carbon transport technologies. Linking electric cars to a renewable energy grid is the best possible option to reduce emissions from the transport sector.
- **Transport demand management:** : Governments should invest in developing, improving and promoting low emission transport options, such as public and non-motorised transport, freight transport management programmes, teleworking and more efficient land use planning in order to limit journeys.

### The key requirements for effective (renewable) energy policies are:

- **Long-term security for the investment:** Investors need to know if energy policy will remain stable over the entire investment period (until the generator is paid off). Investors want a good return on investment, and while there is no universal definition of a "good return," it depends to a large extent on the inflation rate of the country. Germany, for example, has an average inflation rate of 2% per year and a minimum return of investment expected by the financial sector is 6% to 7%. Achieving 10% to 15% returns is seen as extremely good and everything above 20% is seen as suspicious.
- **Long-term security for market conditions:** Investor need to know if the electricity or heat from the power plant can be sold to the market for a price that guarantees a good return on investment (ROI). If the ROI is high, the financial sector will invest, it is low compared to other investments, and financial institutions will not invest.
- **Transparent Planning Process:** A transparent planning process is key for project developers, so they can sell the planned project to investors or utilities. The entire licensing process must be clear and transparent.
- **Access to the grid:** Fair access to the grid is essential for renewable power plants. If no grid connection is available or if the costs to access the grid are too high, the project will not be built. In order to operate a power plant, investors must know if the asset can reliably deliver and sell electricity to the grid. If a specific power plant (such as a wind farm) does not have priority access to the grid, the operator might have to switch the plant off when there is an oversupply from other power plants or a bottleneck in the grid. This arrangement can add high risk to the project financing, which might then not be financed or only with a "risk-premium" that lowers the ROI.

### Bankable renewable energy support schemes

Since the early development of renewable energies within the power sector, there has been an on-going debate about the best and most effective type of support scheme. The European Commission published a survey in December 2005, which concluded that feed-in tariffs are by far the most efficient and successful mechanism. A more recent update of this report, presented in March 2010 at the IEA Renewable Energy Workshop by the Fraunhofer Institute underscores the same conclusion. The Stern Review on the Economics of Climate Change also concluded that feed-in tariffs “achieve larger deployment at lower costs”. Globally more than 40 countries have adopted some version of the system.

Although the organisational form of these tariffs differs from country to country, some criteria have emerged as essential for successful renewable energy policy. At the heart of these is a reliable, bankable support scheme for renewable projects to provide long-term stability and certainty. Bankable support schemes result in lower-cost projects because they lower the risk for both investors and equipment suppliers. The cost of wind power in Germany is up to 40% cheaper than in the United Kingdom, for example, partly because the support system is more secure and reliable.

For developing countries, feed-in laws would be an ideal mechanism to boost the development of new renewable energy. The extra costs to consumers’ electricity bills are an obstacle for countries with low average incomes. However, countries that build wind and solar projects today do not face the high costs that Germany, for instance, did only a few years ago, so the cost impact on countries that start now will be much lower. In order to enable technology transfer from Annex 1 countries under the Kyoto Protocol to developing countries, a mix of a feed-in laws, international finance, and emissions trading could establish a locally based renewable energy infrastructure and industry with help from wealthier countries.

Finance for renewable energy projects is one of the main obstacles in developing countries. While large-scale projects have fewer funding problems, there are difficulties for small, community-based projects, even though they have a high degree of public support. The experience from micro credits for small hydro projects in Bangladesh, for example, and wind farms in Denmark and Germany shows how economic benefits can flow to local communities. With careful project planning based on good local knowledge and understanding, projects can achieve local involvement and acceptance. When the community identifies with the project (as opposed to the project being forced on the community), the result is generally faster bottom-up growth of the renewable energy sector.

The four main elements for successful renewable energy support schemes are therefore:

- A clear, bankable pricing system.
- Priority access to the grid with clear identification of who is responsible for the connection, and how it is incentivised.
- Clear, simple administrative and planning permission procedures.
- Public acceptance/support.

The first is fundamental, but it is insufficient without the other three elements.

### Greenpeace and the renewable industry: required changes in the energy sector:

Greenpeace and the renewable energy industry share a clear agenda for the policy changes which need to be made to encourage a shift to renewable sources.

The main demands are:

1. Phase out all subsidies for fossil fuels and nuclear energy.
2. Internalise external (social and environmental) costs through carbon taxation and/or ‘cap and trade’ emissions trading.
3. Mandate strict efficiency standards for all energy consuming appliances, buildings and vehicles.
4. Establish legally binding targets for renewable energy and combined heat and power generation.
5. Set ambitious and mandatory targets for the short, mid and long term along with supportive policies for their implementation;
6. Reform electricity markets by guaranteeing priority access to the grid for renewable power generators.
7. Establish cross-sectorial RE support schemes to exploit synergies between the power, heating/cooling and transport sectors.
8. Provide defined and stable returns for investors, for example through feed-in tariff payments.
9. If changing circumstances, such as plummeting costs, require a transition to new policy mechanisms, interruption must be avoided and predictability needs to remain for investors;
10. Increase research and development budgets for renewable energy and energy efficiency.

# THE ENERGY [R]EVOLUTION CONCEPT

STATUS QUO OF THE  
GLOBAL ENERGY SECTOR

SETTING UP AN ENERGY  
[R]EVOLUTION SCENARIO

THE ENERGY [R]EVOLUTION LOGIC

THE "5 STEP IMPLEMENTATION"

3



“

100%  
renewables  
requires  
system-thinking”

IMAGE TYPHOON MAYSAK, AN UNUSUALLY EARLY STORM FOR THE NORTHWEST PACIFIC, STRENGTHENED ABRUPTLY ON THE LAST DAY OF MARCH 2015 AND GREW INTO A CATEGORY 5 SUPER TYPHOON.

Since the first Energy [R]evolution was published a decade ago, the energy sector has changed significantly. Renewable energy technologies have become mainstream in most countries as a consequence of dramatically reduced costs. A future renewable energy supply is no longer science fiction, but work in progress.

However, growth rates of renewables – especially in the heating/cooling sector and in transport – are far too slow to achieve energy-related CO<sub>2</sub> reductions required to avoid dangerous climate change. A fundamental shift in the way we consume and generate energy must begin immediately and be well underway before 2020 in order to avert the worst impacts of climate change.<sup>1</sup> We need to limit global warming to less than 2° Celsius, above which the impacts become devastating.

### 3.1 STATUS QUO OF THE GLOBAL ENERGY SECTOR

Every day, The International Energy Agency published an evaluation of the current development of the Energy Sector in May 2015 (IEA – TCEP 2015),<sup>2</sup> which concluded that the implementation of renewables and energy efficiency is successful but too slow to meet the 2°C target. Here are some of the IEA's conclusions:

**Costs:** Increasingly, renewables are competitive with new fossil fuel plants, and the cost gap between renewable electricity and fossil power from new plants is closing worldwide. Nonetheless, markets still do not reflect the true environmental cost of power generation from fossil fuels.

**Policy:** Power markets must be redesigned to accommodate variable, distributed renewables. Obstacles still exist for the financing of renewable energy projects and grid connections, thereby slowing down the transition. But the worst policy mistakes are uncertainty and retroactive changes.

**Technology:** Cogeneration and renewable heat have both grown in absolute terms, but are not increasing quickly enough as a share of energy supply. The share of cogeneration in power supply has even stagnated. Likewise, battery storage has mainly been developed for mobility up to now but is increasingly used for frequency regulation to integrate a greater share of variable renewables.

**Mobility:** Electric vehicles are catching on, with an increasing number of manufacturers now offering hybrid and electric options. Fuel efficiency standards have also made light vehicles more efficient. The standard should now be applied to larger trucks and buses.

**Buildings:** The technologies are available, and targets are in place in many regions. However, the rate and depth of energy-efficient renovations needs to increase for true progress to be made in this sector because the building stock has a service life counted in decades.

The *Renewable Policy Network for the 21<sup>st</sup> Century* (REN21) has undertaken a global renewable market analysis each year

in June since 2004. The publication – “Renewables – Global Status Report” – is among the most comprehensive global and national surveys of the renewable industry sector. According to their latest edition, the global renewable energy market in 2014 was dominated by three power generation technologies: Solar photovoltaics (PV), wind, and hydro. Combined, these technologies added 127 GW of new power generation capacity worldwide. By year's end, renewables made up an estimated 60% of net additions to the global power capacity. In several countries renewables represented a higher share of added capacity (REN21-2015).<sup>3</sup> The increase in market volume and strong global competition led to significant cost reductions, especially for solar PV and wind power. As a result, other renewable energy technologies were under pressure to lower costs, particularly in the heating and cooling sector due to the increased competitiveness of electricity-based heating systems. Cost competitive solar PV in combination with electrical heat pumps became economically viable, negatively impacting the solar thermal collector market.

While developments in the renewable energy, heating and cooling sector were slower than in the power sector, the markets for solar thermal collectors and geothermal heat pumps grew by 9%. Bio-heat production remained stable in 2014, increasing only 1% from 2013 levels. The lack of infrastructure for heating systems and an uncertain policy environment impeded the development of the renewable energy renewable energy heating market (REN21-2015).

The number of electric vehicles worldwide doubled year over year to 665,000. E-mobility and recent developments in battery storage (including significant cost reductions) are likely to change the future role of renewable energy in the transport sector. Biofuels, however, are still the main renewable fuel source used in the transport sector and grew 8.4% in 2014 compared the previous year (REN21-2015).

In conclusion, developments in the heating/cooling sector and the transport sector in particular are far too slow. Despite all the success in the renewable power sector, the extreme growth of coal power generation, especially in China, undercuts many successes with renewables. However, the first sign of a stagnation of coal demand in China – even a small decline for the first time in 2014 – provides reason to hope. The political framework of energy markets must adapt to the new emerging, mostly distributed energy technologies in order to support the transition to 100% renewable energy supply.

Thus, Energy [R]evolution has begun, especially in the power sector, but heating and transport significantly lag behind. Overall, the transition from fossil and nuclear fuels to renewables is too slow, and energy demand is still growing too quickly.

#### REFERENCES

- 1 IPCC – SPECIAL REPORT RENEWABLES, CHAPTER 1, MAY 2011.
- 2 (IEA – TCEP 2015) TRACKING CLEAN -ENERGY PROGRESS 2015; ENERGY TECHNOLOGY PERSPECTIVES 2015 EXCERPT; IEA INPUT TO THE CLEAN ENERGY MINISTERIAL; INTERNATIONAL ENERGY AGENCY; 9 RUE DE LA FÉDÉRATION; 75739 PARIS CEDEX 15, FRANCE; WWW.IEA.ORG.
- 3 (REN21-2015); RENEWABLES 2015 GLOBAL STATUS REPORT, PARIS; REN21 SECRETARIAT; WWW.REN21.NET; ISBN 978-3-9815934-6-4

### 3.2 SETTING UP AN ENERGY [R]EVOLUTION SCENARIO

This section explains the basic principles and strategic approach of the development of the Energy [R]evolution concepts, which have served as a basis for the scenario modelling since the very first Energy [R]evolution scenario published in 2005. The Energy [R]evolution scenario series follows a “seven-step logic,” which stretches from the evaluation of natural resource limits to key drivers for energy demand and energy efficiency potentials, an analysis of available technologies and their market development potential, and specific policy measures required to implement a theoretical concept on real markets. This concept, however, has been constantly improved as technologies develop and new technical and economical possibilities emerge.

The seven steps are:

1. Define natural limits for the climate and fuel resources.
2. Define renewable energy resource limits.
3. Identify drivers for demand.
4. Define efficiency potentials by sector.
5. Establish time lines for implementation.
6. Identify required infrastructure.
7. Identify required policies.

One of the major changes we have made in the Energy [R]evolution concept over the past years is to give solar photovoltaics a significantly increasing role in the energy sector and electric mobility a more important role due to better battery technology. Both solar PV and storage technologies are potentially disruptive; they could turn the energy sector on its head a relatively quickly.

### 3.3 THE ENERGY [R]EVOLUTION LOGIC

#### 1. Define natural limits:

**The phase-out cascade for fossil fuels:** Geological resources of coal could provide several hundred years of fuel, but we cannot burn them and keep within safe climate change limits. Thus, lignite – as the most carbon intensive coal – must be phased-out first, followed by hard coal. The use of oil will be phased-out in the pace of production depletion of existing oil wells (see chapter 5), and no new deep sea and Arctic / Antarctic oil wells will be opened.

Gas production follows the same logic as oil and will be phased out as the last fossil fuel.

#### Reduce energy-related carbon dioxide to zero by mid-century:

There is only so much carbon that the atmosphere can absorb. Each year we emit almost 30 billion tonnes of carbon equivalents. The Energy [R]evolution scenario has a target to phase-out energy-related CO<sub>2</sub> emissions by 2050. In addition, the regional transition towards carbon-free energy supply aims to achieve energy equity – shifting towards a fairer worldwide distribution of efficiently-used supply – as soon as technically possible. By 2040, the average per capita emission should be between 0.5 and 1 tonne of CO<sub>2</sub>.

#### 2. Define renewable energy resource limits:

##### Renewable Energy Resource – mapping the future energy mix:

The 5 renewable energy resources (solar, wind, hydro, geothermal and ocean) are available in different quantities – both by region and by season. Specific renewable energy potential maps are available from a number of scientific research institutions for each country around the world. The German Aerospace Centre takes part in the global mapping project of the International Renewable Energy Agency (IRENA), which provides detailed data for all renewable energy resources (IRENA-Global Atlas 2015).<sup>4</sup> The various regional renewable energy resources influence the projected energy mix in Energy [R]evolution scenarios.

##### Bioenergy – an important resource with limited sustainable potential:

Bioenergy is needed for fossil fuel replacement where no other technical alternative is available. Energy [R]evolution scenarios use bioenergy especially for industrial process heat, aviation, shipping and heavy machinery. Greenpeace identified the sustainable bioenergy potential globally in a scientific survey in 2008 at around 80 to maximum 100 EJ per year (DBFZ 2008).<sup>5</sup> The overall sustainable bioenergy potential is, however, subject to change due to technical and scientific development and / or change of usage. An increased use of biomass for plastics, for example, would reduce the resources available for energy conversion.

#### REFERENCES

- 4 (IRENA-GLOBAL ATLAS 2015) GLOBAL ATLAS FOR RENEWABLE ENERGY; INTERNATIONAL RENEWABLE ENERGY AGENCY (IRENA); ABU DHABI /UAE; BONN/GERMANY; [HTTP://IRENA.MASDAR.AC.AE/#](http://irena.masdar.ac.ae/#); JULY 2015.
- 5 (DBFZ 2008); GLOBAL BIOMASS POTENTIALS – INVESTIGATION AND ASSESSMENT OF DATA – REMOTE SENSING IN BIOMASS POTENTIAL RESEARCH – COUNTRY SPECIFIC ENERGY CROP POTENTIAL; SEIDENBERGER ET. AL.; DEUTSCHES BIOMASSEFORSCHUNGSZENTRUM; LEIPZIG/GERMANY, JUNE 2008.

### 3. Identify drivers for demand:

**Equity and fair access to energy for all:** The global and regional population development pathways are taken from United Nations projections (UN 2014).<sup>6</sup> Greenpeace does neither undertake any of its own population projections, nor is family planning part of the Energy [R]evolution energy scenario efficiency concept. However, a focus for future energy demand projections lies on a fair distribution of benefits and costs within societies, between nations, and between present and future generations. At one extreme, a third of the world's population has no access to electricity, whilst the most industrialised countries consume much more than their fair share. The Energy [R]evolution concept aims to supply energy for an equal living standard for every person by 2050 if required economic development is believed to take place. (For further information, see chapter 5.)

**Decouple growth from fossil fuel use:** The projections for economic growth are based on the International Energy Agencies (IEA) World Energy Outlook projections (for further information, see chapter 5). Starting in the developed countries, economic growth must be fully decoupled from fossil fuel usage. It is a fallacy to suggest that economic growth must be predicated on increased fossil fuel combustion.

### 4. Define efficiency potentials by sector:

**Energy not used is the cheapest; smart use of energy needed:** Electrical appliances, industrial process, heating and cooling of buildings, and all forms of transport technologies still have significant efficiency potential. The latest available technologies in all sectors are implemented within the range of normal replacement rates. Energy [R]evolution scenarios focus on efficiency rather than sufficiency in the power and heating/cooling sector. The transport sector requires sufficiency especially in regard to usage of individual cars and aviation. A modular shift from road to rail and from air to rail where ever possible as an example of sufficiency.

### 5. Establish time lines for implementation:

**There is no renewable energy shortage as such:** The sun sends more energy to the earth surface per day than we consume each year. However, renewable energy technologies need to be engineered, installed, and operated, which requires skilled labour, financial resources and adapted energy policies. The transition from a fossil to a largely renewable energy supply system will take time. Energy [R]evolution scenarios take past experiences into account in determining how fast renewable energy technologies can scale up. In particular, the experience of Denmark, Germany and China during the last decade showed that a certain time is needed to train workers and set up required industries and infrastructure. An overheated renewable industry with low-quality products does more damage than good to a long-term transition. Thus, Energy [R]evolution scenarios are ambitious but not unrealistic. The first decade of our RE development pathways are based on industries projections such as from the Global Wind Energy Council (GWEC 2015)<sup>7</sup> and Solar Power Europe (SPE 2015).<sup>8</sup>

### 6. Identify required infrastructure:

**Smart grids are key, as is solar and wind power integration:** Increased shares of distributed solar photovoltaic and onshore wind in distribution and medium voltage grids and offshore wind and concentrated solar power generation connected to transmission grids require the development of infrastructure, both for the physical setup and for management (Brown et. al. 2014).<sup>9</sup> Also, the distribution of generation capacities across different voltage levels has a significant influence on required grid expansion and/or dispatch capacities (Teske 2015).<sup>10</sup> Existing gas pipelines and storage facilities might be available for the transport and storage of renewable hydrogen and/or methane. Existing gas power plants can therefore be used as dispatch plants to avoid stranded investments.

**Storage – the next big thing:** The development of electric vehicles has triggered more research in storage technologies, especially batteries. Increased shares of wind and solar caused another wave of research and market development for storage technologies, such as hydrogen, renewable methane and pumped hydro power plants. Storage technologies have thus improved significantly. Energy [R]evolution scenarios, however, aim to minimize storage needs for the next decade as costs are expected to remain high for that time frame. In the medium to long term, storage technologies are needed especially to replace fossil fuels with electricity in the transport sector.

### 7. Identify required policies:

**New energy markets need new energy policies:** Climate and energy policy need to go hand in hand. The UNFCCC process (see chapter 1) is key to protect the global climate, just as national energy policies are key to implement the required emission reduction with renewables and energy efficiency. The Energy [R]evolution scenarios are based on the experience documented in policy analysis, such as from REN 21 (REN21),<sup>11</sup> IRENA (IRENA 2015)<sup>12</sup> and the IEA (IEA 2015 A). Specific policy recommendations are documented in chapter 2 of this report.

#### REFERENCES

- 6 (UN 2014) ADD EXACT REFERENCE FOR POPULATION PROJECTION.
- 7 (GWEC 2015) GLOBAL WIND REPORT: ANNUAL MARKET UPDATE; MARKET PROJECTION 2015 – 2019; BRUSSELS / BELGIUM; MAY 2015.
- 8 (SPE 2015) GLOBAL MARKET OUTLOOK FOR SOLAR POWER 2015 – 2019; SOLAR POWER EUROPE; BRUSSELS / BELGIUM; MAY 2015.
- 9 (BROWN ET. AL. 2014) OPTIMISING THE EUROPEAN TRANSMISSION SYSTEM FOR 77% RENEWABLES BY 2030; TOM BROWN, PETER-PHILIPP SCHIERHORN, ECKEHARD TRÖSTER, THOMAS ACKERMANN; ENERGYNAUTICS GMBH, ROBERT-BOSCH-STRASSE 7, 64293 DARMSTADT, GERMANY.
- 10 (TESKE 2015); BRIDGING THE GAP BETWEEN ENERGY- AND GRID MODELS - DEVELOPING AN INTEGRATED INFRASTRUCTURAL PLANNING MODEL FOR 100% RENEWABLE ENERGY SYSTEMS IN ORDER TO OPTIMIZE THE INTERACTION OF FLEXIBLE POWER GENERATION, SMART GRIDS AND STORAGE TECHNOLOGIES; DISSERTATION; EUROPA UNIVERSITÄT FLENSBURG/GERMANY, SVEN TESKE DR. RER. POL.; DIPL.-ING.; JUNE 2015.
- 11 (REN21-2015); RENEWABLES 2015 GLOBAL STATUS REPORT, PARIS: CH. 4; REN21 SECRETARIAT; WWW.REN21.NET; ISBN 978-3-9815934-6-4.
- 12 (IRENA 2015 A) RENEWABLE ENERGY TARGET SETTING, INTERNATIONAL RENEWABLE ENERGY AGENCY; JUNE 2015, [HTTP://WWW.IRENA.ORG/DOCUMENTDOWNLOADS/PUBLICATIONS/IRENA\\_RE\\_TARGET\\_SETTING\\_2015.PDF](http://www.irena.org/documentdownloads/publications/irena_re_target_setting_2015.pdf)

### 3.4 THE “5 STEP IMPLEMENTATION”

In 2013, renewable energy sources accounted for 19% of the world’s final energy demand. Modern renewables, such as solar, wind and geothermal energy, accounted for 10%, while traditional biomass contributed 9%. The latter often causes environmental damage and thus need to be replaced with new renewables as well. The share of renewable energy in electricity generation was 22.8% in 2013, a 5% increase over the past 4 years. About 78% of primary energy supply today still comes from fossil fuels<sup>13</sup> - a decrease of 3 % over the past 4 years.

Now is the time to make substantial structural changes in the energy and power sector within the next decade. Many power plants in industrialised countries, such as the USA, Japan and the European Union, are nearing retirement; more than half of all operating power plants are over 20 years old. At the same time developing countries, such as China, India, South Africa and Brazil, are looking to satisfy the growing energy demand created by their expanding economies.

Worldwide, there is good news: PV and wind are growing strongly. In 2015, roughly 50 GW of solar is expected to be installed, up from 30 GW annually at the beginning of this decade. This year, the global PV market also crossed the 200 GW threshold. By the end of the decade, nearly half that much could be installed annually. Likewise, after years of roughly 30-40 GW of annual additions, the wind market grew in 2014 by over 50 GW and will cross the 400 GW threshold this year. This market as well could grow to around 90 GW annually by the end of this decade. Because the capacity factors of wind

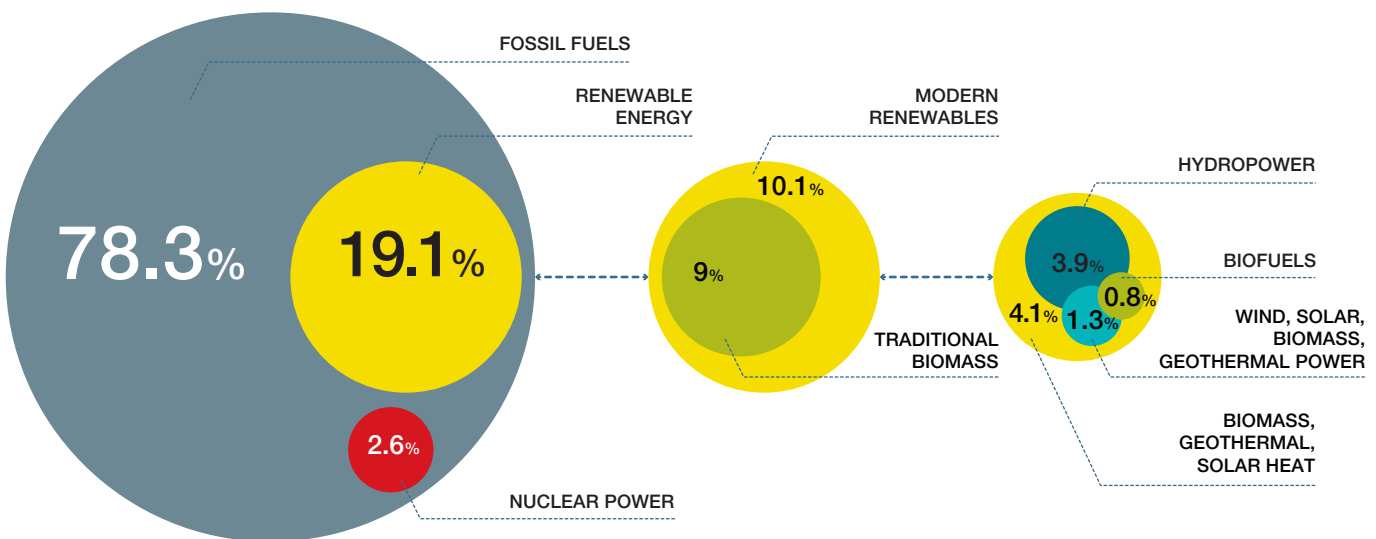
turbines are generally double that of PV, twice as much wind power would be generated from these additions.

Within this decade, the power sector will decide how new electricity demand will be met, either by fossil and nuclear fuels or by the efficient use of renewable energy. The Energy [R]evolution scenario puts forwards a policy and technical model for renewable energy and cogeneration combined with energy efficiency to meet the world’s needs.

Renewable energy and cogeneration – both as central-station power plants and distributed units – have to grow faster than overall global energy demand. Both approaches must replace old generating technologies and deliver the additional energy required in the developing world.

A transitional phase is required to build up the necessary infrastructure because it is not possible to switch directly from a large-scale fossil and nuclear energy system to a fully renewable energy supply. Whilst remaining firmly committed to the promotion of renewable sources of energy, we appreciate that conventional natural gas, used in appropriately scaled cogeneration plants, is valuable as a transition fuel, and can also drive cost-effective decentralisation of the energy infrastructure. With warmer summers, tri-generation – which incorporates heat-fired absorption chillers to deliver cooling capacity in addition to heat and power – will become a valuable means of achieving emissions reductions. The Energy [R]evolution envisages a development pathway away from the present energy supply structure and towards a sustainable system. There are three main stages to this.

FIGURE 3.1 | ESTIMATED RENEWABLE ENERGY SHARE OF GLOBAL FINAL ENERGY CONSUMPTION 2013



source REN21-2015.

#### REFERENCES

13 IEA WORLD ENERGY OUTLOOK 2014, PARIS NOVEMBER 2014.

### 3 STEP 1: ENERGY EFFICIENCY AND EQUITY

The Energy [R]evolution requires an ambitious exploitation of energy efficiency. The focus is on current best practices and products, along with probable future technologies, assuming continuous innovation. The energy savings are fairly equally distributed over the three sectors – industry, transport and domestic/business. Intelligent use, not abstinence, is the basic philosophy.

The most important energy saving options are improved heat insulation and building design, super-efficient electrical machines and drives, replacement of old style electrical heating systems by renewable heat production (such as solar collectors) and a reduction in energy consumption by vehicles used for goods and passenger traffic.

By the end of this decade, new buildings in Europe will have to be “nearly zero-carbon,” which is an excellent step forwards, though it comes a bit late – Passive House architecture was proven two decades ago. This energy-efficient architecture can be used worldwide in almost all climates, both to reduce heating demand (such as in southern Canadian cities) as well as cooling demand (from Las Vegas to Dubai). However, the greatest gains are to be made not in new buildings, but in renovations. Here, governments must speed up the renovation rate of existing building stock, and all renovations must be ambitious in light of long building service lives. Moreover, the comfort gains from such architecture make these buildings a pleasure to live and work in; here, intelligent energy use is clearly about better living, not abstinence.

Industrialised countries currently use energy most inefficiently. They can reduce their consumption drastically without losing either housing comfort or gadgets. The Energy [R]evolution scenario depends on OECD countries to save energy as developing countries increase theirs. The ultimate goal is stable global energy consumption within the next two decades. Another aim is to ‘energy equity’.

A dramatic reduction in primary energy demand compared to the Reference scenario – but with the same GDP and population development - is a crucial prerequisite for achieving a significant share of renewable energy sources in the overall energy supply, compensating for the phasing out of nuclear energy and reduction in fossil fuel consumption.

### STEP 2: THE RENEWABLE ENERGY REVOLUTION

#### Decentralised energy and large scale renewables

Decentralised energy is connected to a local distribution network system, to which homes, offices, and small businesses are generally connected. Energy [R]evolution scenarios make extensive use of Distributed Energy (DE): energy generated at or near the point of use. We define distributed power generation as applications connected to low-and medium-voltage power lines with an average transport distance from several hundred meters up to around 100 kilometres. Several different distributed power plant technologies are available: solar photovoltaics, onshore wind turbines, run-of-river hydro power plants, bioenergy and geothermal power plants, and potentially near-shore ocean energy plants.



The dominant renewable electricity source is now wind power, but photovoltaics will catch up in the future. Significant cost reduction of solar photovoltaic roof-top systems is leading to “grid parity” in almost all industrialized countries. Households and small businesses can then produce their own solar power for the same or a lower cost than rates for grid electricity; on-site power generation - a term usually used for industry - now makes economic sense for the private sector.

Distributed energy also includes stand-alone systems for heating / cooling either connected to district heating networks or for a single building supply, such as solar thermal collectors, bio energy heat systems and (geothermal) heat pumps. A hybrid between renewables and energy efficiency, heat pumps convert one unit of electricity into up to 4 units of heat.

All these decentralized technologies can be commercialised for domestic users to provide sustainable, low-carbon energy. Increased shares of distributed generation technologies require adapted energy policies for “prosumers” – consumers who produce own energy.

This option opens up a whole new market for solar photovoltaics and turns the business model for utilities on its head (see **New Business Models**). Those who were once captive utility customers will become utility competitors. Energy [R]evolution scenarios assume that private consumer and small and medium enterprises (SME) will meet most of

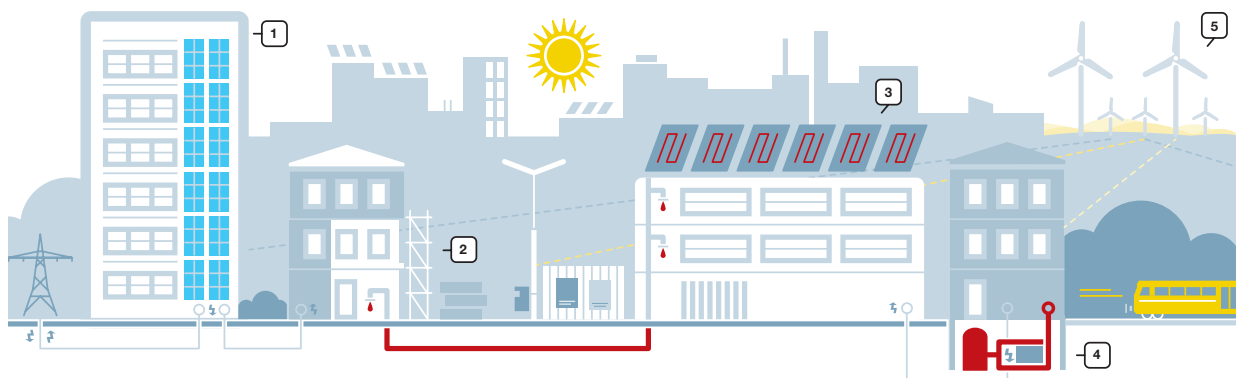
their electricity needs with solar photovoltaic and storage if space to set up the system is accessible. Therefore, utilities will lose most of their customers connected to the distribution grid until 2030 for electricity sales from centralized power plants. Therefore, utilities will have to move from selling energy to selling energy services by managing the operation and dispatch of decentralized generation capacity.

Industry and business can use cogeneration power plants and co-generation batteries for on-site power generation to cover their own power needs. Surplus power will be sold to the grid, while excess heat can be piped to nearby buildings, a system known as combined heat and power. For a fuel like (bio-) gas, almost all the input energy is used, not just a fraction as with traditional central-station fossil fuel electricity plants.

While a large proportion of global energy in 2050 will be produced by decentralised energy sources, large-scale renewable energy will still be needed for an energy revolution. Large offshore wind farms and concentrating solar power (CSP) plants in the Sunbelt regions of the world will therefore have an important but broader role to play. Offshore wind turbines produce electricity more hours of the day, thereby reducing the need for backup generators, and CSP with storage is dispatchable. Centralized renewable energy will also be needed to provide process heat for industry and desalination (in the case of CSP), to supply increase power demand for the heating and transport sector, and to produce synthetic fuels for the transport sector.

### FIGURE 3.2 | A DECENTRALISED ENERGY FUTURE

EXISTING TECHNOLOGIES, APPLIED IN A DECENTRALISED WAY AND COMBINED WITH EFFICIENCY MEASURES AND ZERO EMISSION DEVELOPMENTS, CAN DELIVER LOW CARBON COMMUNITIES AS ILLUSTRATED HERE. POWER IS GENERATED USING EFFICIENT COGENERATION TECHNOLOGIES PRODUCING BOTH HEAT (AND SOMETIMES COOLING) PLUS ELECTRICITY, DISTRIBUTED VIA LOCAL NETWORKS. THIS SUPPLEMENTS THE ENERGY PRODUCED FROM BUILDING INTEGRATED GENERATION. ENERGY SOLUTIONS COME FROM LOCAL OPPORTUNITIES AT BOTH A SMALL AND COMMUNITY SCALE. THE TOWN SHOWN HERE MAKES USE OF – AMONG OTHERS – WIND, BIOMASS AND HYDRO RESOURCES. NATURAL GAS, WHERE NEEDED, CAN BE DEPLOYED IN A HIGHLY EFFICIENT MANNER.



- 1. PHOTOVOLTAIC, SOLAR FAÇADES** WILL BE A DECORATIVE ELEMENT ON OFFICE AND APARTMENT BUILDINGS. PHOTOVOLTAIC SYSTEMS WILL BECOME MORE COMPETITIVE AND IMPROVED DESIGN WILL ENABLE ARCHITECTS TO USE THEM MORE WIDELY.
- 2. RENOVATION CAN CUT ENERGY CONSUMPTION OF OLD BUILDINGS** BY AS MUCH AS 80% - WITH IMPROVED HEAT INSULATION, INSULATED WINDOWS AND MODERN VENTILATION SYSTEMS.
- 3. SOLAR THERMAL COLLECTORS** PRODUCE HOT WATER FOR BOTH THEIR OWN AND NEIGHBOURING BUILDINGS.
- 4. EFFICIENT THERMAL POWER (CHP) STATIONS** WILL COME IN A VARIETY OF SIZES - FITTING THE CELLAR OF A DETACHED HOUSE OR SUPPLYING WHOLE BUILDING COMPLEXES OR APARTMENT BLOCKS WITH POWER AND WARMTH WITHOUT LOSSES IN TRANSMISSION.
- 5. CLEAN ELECTRICITY** FOR THE CITIES WILL ALSO COME FROM FARTHER AFIELD. OFFSHORE WIND PARKS AND SOLAR POWER STATIONS IN DESERTS HAVE ENORMOUS POTENTIAL.

### 3 STEP 3: THE TRANSPORT REVOLUTION

#### Moving around with different technologies and less energy

Switching to 100% renewables is most challenging in the transport sector. Today 92% of the transport energy comes from oil and only 1% from electricity (IEA 2015 B).<sup>14</sup> A simple “fuel switch” from oil to bio energy and electricity is neither technically possible nor sustainable. While there is an urgent need to expand electric mobility – public and individual transport technologies such as trains, busses, cars, and trucks – we also need to re-think our current mobility concept as such. The design of (mega-) cities has a huge influence whether people have to commute long distances or if they can walk or bike to work (WFC 2014).<sup>15</sup> On the other hand, increasing urban populations offer an opportunity to increase the usage of environmentally friendly mass transit systems. The transport of freight needs to move from road to rail and – if possible – from aviation to ships, which requires better logistics and new, more efficiency transport technologies (see chapter 12).

Cars evolve in Energy [R]evolution scenarios. All potentials to make cars lighter and the combustion engine more efficient are exploited first. By around 2025, the car market moves via hybrid drives towards fully electric drives. The e-vehicle market is still nascent in 2015, and technical uncertainties remain, especially in regard to the storage technologies. We

therefore do not expect a real turnaround with significant oil reduction effect before 2025. However the technical evolution must start now in order to be ready by then.

The use of biofuels is limited by the availability of sustainably grown biomass. It will primarily be committed to heavy machinery, aviation and shipping, where electricity does not seem to be an option for the next few decades. Outside the transport sector, biomass is needed for specific industries to supply process heat and carbon – not to mention as a raw material outside the energy sector. Unlike previous Energy [R]evolution scenarios, this one no longer includes biofuels for private cars.<sup>16</sup> Electric vehicles will therefore play an even more important role in improving energy efficiency in transport and substituting for fossil fuels after 2025.

Overall, achieving an economically attractive growth of renewable energy sources requires a balanced and timely mobilisation of all technologies. Such a mobilisation depends on resource availability, cost reduction potential and technological maturity. And alongside technology driven solutions, lifestyle changes - like simply driving less and using more public transport – have a huge potential to reduce greenhouse gas emissions. Fortunately, these new behaviour patterns will be perceived as improvements, not compromises; young people around the world already increasingly prefer to spend time on their smart phones and buses and trains rather than drive.

#### REFERENCES

- <sup>14</sup> (IEA 2015 B) ENERGY AND CLIMATE CHANGE – WORLD ENERGY OUTLOOK SPECIAL REPORT; INTERNATIONAL RENEWABLE ENERGY AGENCY; MAY 2015.
- <sup>15</sup> (WFC 2014); REGENERATIVE CITIES – COMMISSION ON CITIES AND CLIMATE CHANGE; HAFEN CITY UNIVERSITY, WORLD FTURE COUNCIL; SEPTEMBER 2014.
- <sup>16</sup> SEE CHAPTER 12.

**STEP 4: SMART INFRASTRUCTURE TO SECURE RENEWABLES 24/7**

Because renewable energy relies mostly on natural resources, which are not available at all times, some critics say this makes it unsuitable for large portions of energy demand. Yet, Denmark got around 40 percent of its electricity from wind power alone in 2014; Spain and Portugal, around a quarter. A complete transformation of the energy system will be necessary to accommodate the significantly higher shares of renewable energy expected under the Energy [R]evolution scenario. The grid network of cables and substations that brings electricity to our homes and factories was designed for large, centralised generators running at huge loads, providing ‘base load’ power. Until now, renewable energy has been seen as an additional slice of the energy mix and had had to adapt to the grid’s operating conditions. If the Energy Revolution scenario is to be realised, this situation will have to change.

Renewable energy supply 24/7 is technically and economically possible; it just needs the right policy and the commercial investment to get things moving and ‘keep the lights on’ (GP-EN 2014).<sup>17</sup> The task of integrating renewable energy technologies into existing power systems is similar in all power systems around the world, whether they are large, centralized systems or island systems.

Thorough planning is needed to ensure that the available production can match demand at all times. In addition to balancing supply and demand, the power system must also be able to:

- Fulfil defined power quality standards – voltage/frequency – which may require additional technical equipment in the power system and support from different ancillary services (See Appendix 1 for definitions of terms); and

- Survive extreme situations such as sudden interruptions of supply (such as a fault at a generation unit) or interruption of the transmission system.

**Base load and system balancing**

Power balance aims at keeping frequency in the system consistent. The mains frequency describes the frequency at which AC electricity is delivered from the generator to the end user, and it is measured in hertz (Hz). Frequency varies in a system as the load (demand) changes. In a power grid operating close to its peak capacity, there can be rapid fluctuations in frequency, and dramatic fluctuations can occur just before a major power outage. Typically, power systems were designed around large power stations providing base-load capacity operating almost constantly at full output. These centralized units, typically nuclear or coal power plants, are inflexible generation resources – they don’t “follow load” – change their output to match changing demand – as well as flexible gas turbines and hydropower units, for instance.

Power systems with large amounts of inflexible generation resources, such as nuclear power stations, also require a significant amount of flexible generation resources.

**Priority dispatch for renewables ends “base-generation”**

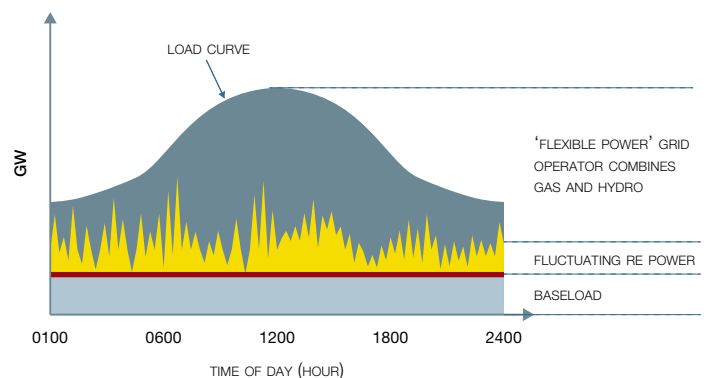
Renewable energy integrated into a smart grid changes the need for base load power. An energy switch based on renewables redefines the need for “base load” power generation. Instead, traditional base load power plants such as coal are replaced by a mix of flexible energy providers that can follow the load during the day and night (such as solar plus gas, geothermal, wind and demand management), without blackouts. The base load is therefore provided by a cascade of flexible power plants – instead of just baseload generation.

**FIGURE 3.3 | THE EVOLVING APPROACH TO GRIDS.****CURRENT SUPPLY SYSTEM:**

- LOW SHARES OF FLUCTUATING RENEWABLE ENERGY
- THE ‘BASE LOAD’ POWER IS A SOLID BAR AT THE BOTTOM OF THE GRAPH.
- RENEWABLE ENERGY FORMS A ‘VARIABLE’ LAYER BECAUSE SUN AND WIND LEVELS CHANGES THROUGHOUT THE DAY.
- GAS AND HYDRO POWER CAN BE SWITCHED ON AND OFF IN RESPONSE TO DEMAND. THIS COMBINATION IS SUSTAINABLE USING WEATHER FORECASTING AND CLEVER GRID MANAGEMENT.
- WITH THIS ARRANGEMENT THERE IS ROOM FOR ABOUT 25 PERCENT VARIABLE RENEWABLE ENERGY.

**TO COMBAT CLIMATE CHANGE MUCH MORE THAN 25 PERCENT RENEWABLE ELECTRICITY IS NEEDED.**

source GREENPEACE ENERGY [R]EVOLUTION 2012.

**REFERENCES**

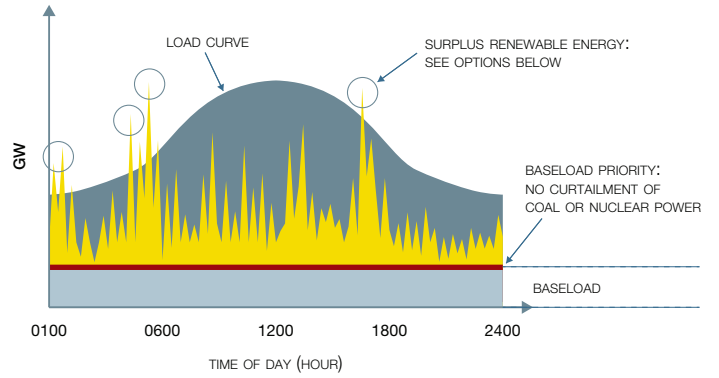
<sup>17</sup> (GP-EN 2014) POWE[R] 2030 -. A EUROPEAN GRID FOR 3/4 RENEWABLE ELECTRICITY BY 2030; GREENPEACE INTERNATIONAL / ENERGINAUTICS; MARCH 2014.

**FIGURE 3.5 | THE EVOLVING APPROACH TO GRIDS.** continued.

**SUPPLY SYSTEM WITH MORE THAN 25 PERCENT FLUCTUATING RENEWABLE ENERGY > BASE LOAD PRIORITY:**

- THIS APPROACH ADDS RENEWABLE ENERGY BUT GIVES PRIORITY TO BASE LOAD
- AS RENEWABLE ENERGY SUPPLIES GROW THEY WILL EXCEED THE DEMAND AT SOME TIMES OF THE DAY, CREATING SURPLUS POWER.
- TO A POINT, THIS CAN BE OVERCOME BY STORING POWER, MOVING POWER BETWEEN AREAS, SHIFTING DEMAND DURING THE DAY OR SHUTTING DOWN THE RENEWABLE GENERATORS AT PEAK TIMES.

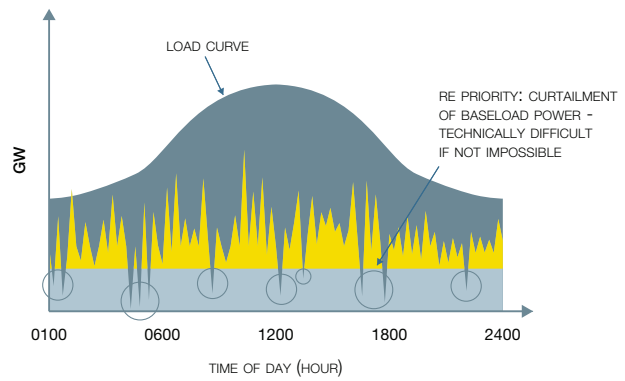
**THIS APPROACH DOES NOT WORK WHEN RENEWABLES EXCEED 50 PERCENT OF THE MIX, AND CANNOT PROVIDE RENEWABLE ENERGY AS 90- 100% OF THE MIX.**



**SUPPLY SYSTEM WITH MORE THAN 25 PERCENT FLUCTUATING RENEWABLE ENERGY – RENEWABLE ENERGY PRIORITY**

- THIS APPROACH ADDS RENEWABLES BUT GIVES PRIORITY TO CLEAN ENERGY.
- IF RENEWABLE ENERGY IS GIVEN PRIORITY TO THE GRID, IT “CUTS INTO” THE BASE LOAD POWER.
- THEORETICALLY, NUCLEAR AND COAL NEED TO RUN AT REDUCED CAPACITY OR BE ENTIRELY TURNED OFF IN PEAK SUPPLY TIMES (VERY SUNNY OR WINDY).
- THERE ARE TECHNICAL AND SAFETY LIMITATIONS TO THE SPEED, SCALE AND FREQUENCY OF CHANGES IN POWER OUTPUT FOR NUCLEAR AND CCS COAL PLANTS.

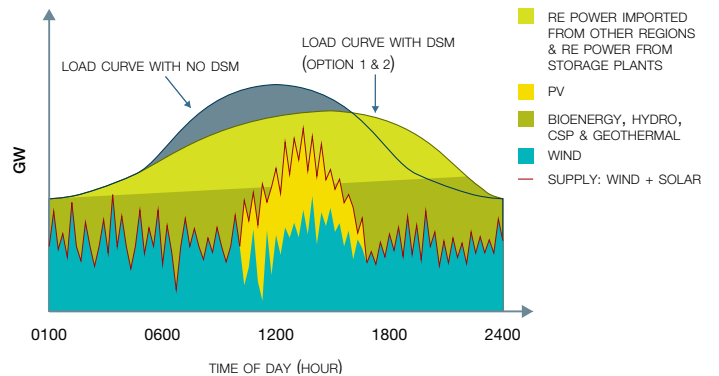
**TECHNICALLY DIFFICULT, NOT A SOLUTION.**



**THE SOLUTION: AN OPTIMISED SYSTEM WITH OVER 90% RENEWABLE ENERGY SUPPLY**

- A FULLY OPTIMISED GRID, WHERE 100 PERCENT RENEWABLES OPERATE WITH STORAGE, TRANSMISSION OF ELECTRICITY TO OTHER REGIONS, DEMAND MANAGEMENT AND CURTAILMENT ONLY WHEN REQUIRED.
- DEMAND MANAGEMENT EFFECTIVELY MOVES THE HIGHEST PEAK AND ‘FLATTENS OUT’ THE CURVE OF ELECTRICITY USE OVER A DAY.

**WORKS!**



source DR. SVEN TESKE / GREENPEACE - 2015.

**The smart-grid vision for the Energy [R]evolution**

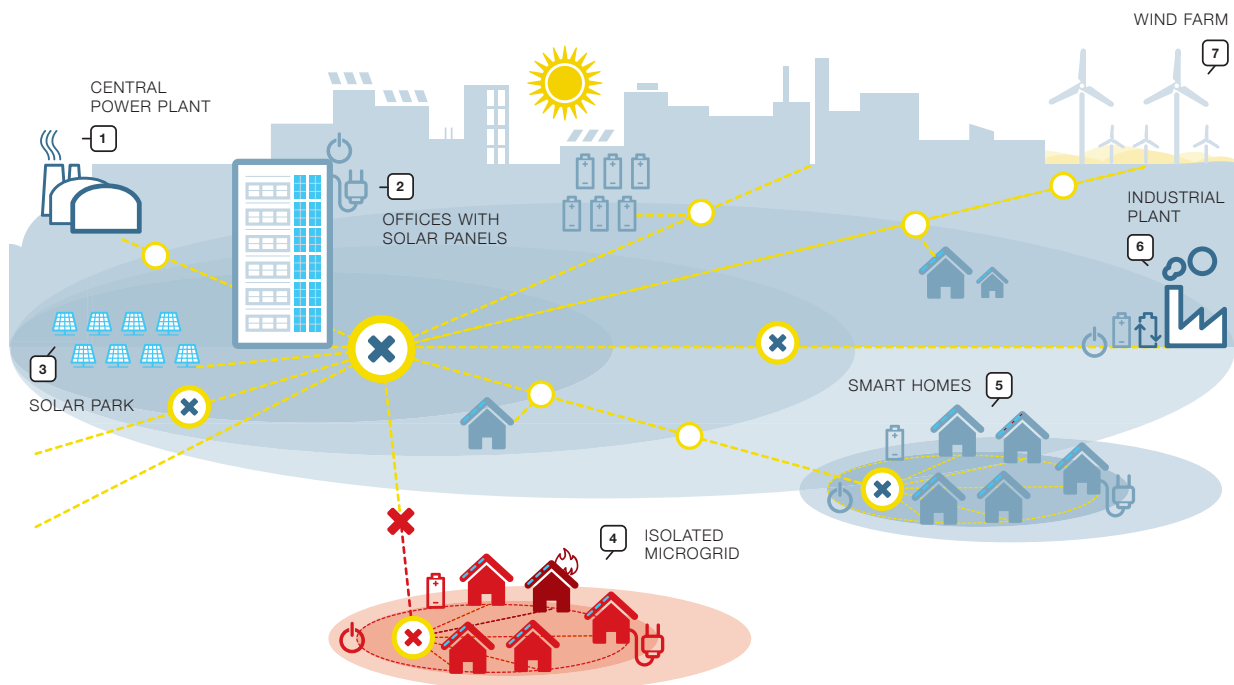
Developing a power system based almost entirely on renewable energy sources will require a new overall power system architecture – including Smart-Grid Technology, which will need substantial amounts of work to emerge (ECOGRID).<sup>18</sup> Figure 3.6 shows a very basic graphic representation of the key elements of future, renewable-based power systems using Smart Grid technology (GP-EN 2009).<sup>19</sup>

**STEP 5: NEW POLICIES TO ENABLE NEW BUSINESS MODELS**

The Energy Revolution scenario will also result in a dramatic change in the business model of energy companies, utilities, fuel suppliers and manufacturers of energy technologies. Decentralised energy generation for self-supply along with utility-scale solar, onshore and offshore wind farms in remote areas will have a profound impact on the way utilities operate by 2020. For instance, these energy sources require no fuel, which will challenge vertically integrated utilities.

**FIGURE 3.4 | THE SMART-GRID VISION FOR THE ENERGY [R]EVOLUTION**

A VISION FOR THE FUTURE – A NETWORK OF INTEGRATED MICROGRIDS THAT CAN MONITOR AND HEAL ITSELF



<p><b>PROCESSORS</b></p> <ul style="list-style-type: none"> <li>EXECUTE SPECIAL PROTECTION SCHEMES IN MICROSECONDS</li> </ul>	<p><b>SENSORS ('ACTIVATED')</b></p> <ul style="list-style-type: none"> <li>DETECT FLUCTUATIONS AND DISTURBANCES, AND CAN SIGNAL FOR AREAS TO BE ISOLATED</li> </ul>	<p><b>SMART APPLIANCES</b></p> <ul style="list-style-type: none"> <li>CAN SHUT OFF IN RESPONSE TO FREQUENCY FLUCTUATIONS</li> </ul>	<p><b>GENERATORS</b></p> <ul style="list-style-type: none"> <li>ENERGY FROM SMALL GENERATORS AND SOLAR PANELS CAN REDUCE OVERALL DEMAND ON THE GRID</li> </ul>
<p><b>SENSORS (ON 'STANDBY')</b></p> <ul style="list-style-type: none"> <li>DETECT FLUCTUATIONS AND DISTURBANCES, AND CAN SIGNAL FOR AREAS TO BE ISOLATED</li> </ul>	<p><b>DISTURBANCE</b></p> <ul style="list-style-type: none"> <li>IN THE GRID</li> </ul>	<p><b>DEMAND MANAGEMENT</b></p> <ul style="list-style-type: none"> <li>USE CAN BE SHIFTED TO OFF PEAK TIMES TO SAVE MONEY</li> </ul>	<p><b>STORAGE ENERGY</b></p> <ul style="list-style-type: none"> <li>GENERATED AT OFF-PEAK TIMES COULD BE STORED IN BATTERIES FOR LATER USE</li> </ul>

source GREENPEACE ENERGY [R]EVOLUTION 2012.

**REFERENCES**

- 18 SEE ALSO ECOGRID PHASE 1 SUMMARY REPORT, AVAILABLE AT: [HTTP://WWW.ENERGINET.DK/NR/RDONLYRES/8B1A4A06-CBA3-41DA-9402-B56C2C28FB0/0/ECOGRIIDK\\_PHASE1\\_SUMMARYREPORT.PDF](http://www.energinet.dk/nr/rdonlyres/8B1A4A06-CBA3-41DA-9402-B56C2C28FB0/0/ECOGRIIDK_PHASE1_SUMMARYREPORT.PDF)
- 19 (GP-EN 2009) EUROPEAN RENEWABLE ENERGY COUNCIL/GREENPEACE REPORT, "[R]ENEWABLES 24/7: INFRASTRUCTURE NEEDED TO SAVE THE CLIMATE", NOVEMBER 2009.

The current model is a relatively small number of large power plants owned and operated by utilities or their subsidiaries, generating electricity for the population. Under the Energy Revolution scenario, around 60 to 70% of electricity will be made by small but numerous distributed power plants. Ownership will shift away from centralised utilities towards more private investors, manufacturers of renewable energy technologies and EPC companies (engineering, procurement and construction). In turn, the value chain for power companies will shift towards project development, equipment manufacturing and operation and maintenance (Figure 4).

Simply selling electricity to customers will play a smaller role; power companies of the future will deliver a total power plant and the required IT services to customers, not just electricity. They will therefore move towards becoming service providers for customers. The majority of power plants will also not require any fuel supply, so fuel production companies will lose their strategic importance.

Today's power supply value chain is broken down into clearly defined players, but a global renewable power supply will inevitably change this division of roles and responsibilities. The following table provides an overview of how the value chain would change in a revolutionised energy mix.

The future pattern under the Energy [R]evolution will see more and more renewable energy companies, such as wind turbine manufacturers becoming involved in project development, installation, and operation and maintenance, whilst utilities will lose their status. Traditional energy supply companies that do not move towards renewable project development will either lose market share or drop out of the market completely.

**Policy defines ownership and investment flows**

In order to organize the transition towards a 100% renewable energy market, specific policies are required to provide planning and investment security for small and medium-size enterprises (SME). Those policies must first and foremost secure access to infrastructure – power lines, gas pipelines and district heating systems – so that electricity, hydrogen, renewable methane and/or renewable heat can be transported to customers. Priority dispatch in all networks is key for project developers and investors as well because the projected amount of renewable energy produced each year is a fundamental cornerstone for financial planning.

**FIGURE 3.5 | CHANGING VALUE CHAIN FOR PLANNING, CONSTRUCTION AND OPERATION OF NEW POWER PLANTS**



source DR. SVEN TESKE / GREENPEACE.

### Future customer groups

The capacity demand of power and/or heat for different customer groups defines the voltage level they are connected to and whether they are connected to the distribution or transmission level of gas pipelines. The interface between customer and infrastructure opens a variety of technology and hence business options for energy service companies.

For households with access to a roof space, for example, the installation of solar photovoltaics is now very often a least-cost option. The cost of photovoltaic electricity has decreased dramatically over the past few years. Parity with retail electricity and oil-based fuels has been reached in many countries and market segments and wholesale parity is approaching in some markets (Beyer 2015).<sup>20</sup>

Figure 3.8 provides a rough overview of technology options for different customer groups with regard to their infrastructural needs.

This section only covers a small share of business model possibilities for utilities. However, it seems relatively clear that not changing the current conventional business model is not an option for utilities either.

German utilities are a good example of future challenges. In 2014, RWE – one of Germany's two biggest utilities along with Eon – posted a 45 percent drop in profits. Power prices are down, and the share of conventional electricity is also falling, so these firms sell less power at lower prices. At RWE, power sales fell by 7.5 percent in 2014 year over year, for instance. The result was 29 percent lower operating profits from conventional power generation. The outlook is also dismal, with year-ahead prices dropping to the lowest level in a decade.

RWE has responded partly by forming a partnership with EPC (Conergy) for significant investments in rooftop solar in Germany. Likewise, Eon is breaking up into two companies: one doing business with conventional energy, and the other with renewables and energy services. This plan is clear evidence that top utility experts understand the incompatibility of conventional energy with renewables. (PV-M 3-2015).<sup>21</sup>

### REFERENCES

<sup>20</sup> (BEYER 2015) PV LCOE IN EUROPE 2014-30; FINAL REPORT, JULY 2015; UNIVERSITY LAPPEENRANTA / FINLAND, DR. CHRISTIAN BREYER; PV TECHNOLOGY PLATFORM; WWW.EUPVPLATFORM.ORG

<sup>21</sup> (PV-M 3-2015); PV MAGAZINE, RWE PROFITS SLUMP AMID CRISIS IN CONVENTIONAL ENERGY; 10TH MARCH 2015; IAN CLOVER; [HTTP://WWW.PV-MAGAZINE.COM/NEWS/DETAILS/BEITRAG/RWE-PROFITS-SLUMP-AMID-CRISIS-IN-CONVENTIONAL-ENERGY\\_100018539](http://www.pv-magazine.com/news/details/beitrag/rwe-profits-slump-amid-crisis-in-conventional-energy_100018539).

# FINANCING THE ENERGY [R]EVOLUTION

RENEWABLE ENERGY  
PROJECT PLANNING BASICS

OVERCOMING BARRIERS TO  
FINANCE AND INVESTMENT  
FOR RENEWABLE ENERGY

HOW TO OVERCOME  
INVESTMENT BARRIERS FOR  
RENEWABLE ENERGY

THE FIRST DECADE OF RENEWABLE  
ENERGY FINANCING

4

RENEWABLE ENERGY  
FINANCING BASICS



“secure, predictable policies are key to financing the energy revolution”

**IMAGE** RIO MAMORÉ, BRAZIL, 2014. THE RIVER FLOWS TOWARD THE NORTH (LEFT IN THESE IMAGES) AND RECEIVES A LARGE AMOUNT OF SEDIMENT AT THE CONFLUENCE WITH THE RIO GRANDE. THE EXTRA SEDIMENT ENHANCES THE GROWTH OF POINT BARS—THE LIGHTER-COLORED, VEGETATION-FREE AREAS ALONG THE INSIDE BENDS OF THE RIVERBANK. NATURAL HABITATS THAT EXIST WITHIN FLOODPLAINS DEPEND ON RIVER MIGRATION TO BOTH RENEW HABITAT AND MAINTAIN THE NATURAL FUNCTIONING OF EXISTING HABITAT.

© NASA EARTH OBSERVATORY IMAGES BY JESSE ALLEN



#### 4.1 RENEWABLE ENERGY PROJECT PLANNING BASICS

The renewable energy market works significantly different than coal, gas and nuclear power markets. The table below provides an overview of the ten steps from “field to an operating power plant” for renewable energy projects in the current market situation. Those steps are similar same for

each renewable energy technology; however, steps 3 and 4 are especially important for wind and solar projects. In developing countries, the government and mostly state-owned utilities might directly or indirectly act as project developers. The project developer might also be work as a subdivision of a state owned utility.

**TABLE 4.1 | HOW DOES THE CURRENT RENEWABLE ENERGY MARKET WORK IN PRACTICE?**

STEP	WHAT WILL BE DONE?	WHO?	NEEDED INFORMATION / POLICY AND/OR INVESTMENT FRAMEWORK
<b>Step 1:</b> SITE IDENTIFICATION	Identify the best locations for generators (e.g. wind turbines) and pay special attention to technical and commercial data, conservation issues and any concerns that local communities may have.	P	Resource analysis to identify possible sites  Policy stability in order to make sure that the policy is still in place once Step 10 has been reached.  Without a certainty that the renewable electricity produced can be fed entirely into the grid to a reliable tariff, the entire process will not start.
<b>Step 2:</b> SECURING LAND UNDER CIVIL LAW	Secure suitable locations through purchase and lease agreements with land owners.	P	Transparent planning, efficient authorisation and permitting.
<b>Step 3:</b> DETERMINING SITE SPECIFIC POTENTIAL	Site specific resource analysis (e.g. wind measurement on hub height) from independent experts. This will NOT be done by the project developer as (wind) data from independent experts is a requirement for risk assessments by investors.	P + M	See above.
<b>Step 4:</b> TECHNICAL PLANNING/ MICROSITING	Specialists develop the optimum configuration or sites for the technology, taking a wide range of parameters into consideration in order to achieve the best performance.	P	See above.
<b>Step 5:</b> PERMIT PROCESS	Organise all necessary surveys, put together the required documentation and follow the whole permit process.	P	Transparent planning, efficient authorisation and permitting.
<b>Step 6:</b> GRID CONNECTION PLANNING	Electrical engineers work with grid operators to develop the optimum grid connection concept.	P + U	Priority access to the grid.  Certainty that the entire amount of electricity produced can be feed into the grid.
<b>Step 7:</b> FINANCING	Once the entire project design is ready and the estimated annual output (in kWh/a) has been calculated, all permits are processed and the total finance concept (incl. total investment and profit estimation) has been developed, the project developer will contact financial institutions to either apply for a loan and/or sell the entire project.	P + I	Long term power purchase contract.  Prior and mandatory access to the grid.  Site specific analysis (possible annual output).
<b>Step 8:</b> CONSTRUCTION	Civil engineers organise the entire construction phase. This can be done by the project developer or another.  EPC (Engineering, procurement & construction) company – with the financial support from the investor.	P + I	Signed contracts with grid operator.  Signed contract with investors.
<b>Step 9:</b> START OF OPERATION	Electrical engineers make sure that the power plant will be connected to the power grid.	P + U	Prior access to the grid (to avoid curtailment).
<b>Step 10:</b> BUSINESS AND OPERATIONS MANAGEMENT	Optimum technical and commercial operation of power plants/farms throughout their entire operating life – for the owner (e.g. a bank).	P + U + I	Good technology & knowledge (A cost-saving approach and “copy + paste engineering” will be more expensive in the long-term).

P PROJECT DEVELOPER. M METEOROLOGICAL EXPERTS. I INVESTOR. U UTILITY.

source SWISS RE 2011.

## 4.2 THE IMPACTS OF CLIMATE CHANGE

The Swiss RE Private Equity Partners have provided an introduction to renewable energy infrastructure investing (Swiss RE – 2011)<sup>1</sup> describing what makes renewable energy projects different from fossil-fuel based energy assets from a finance perspective:

- Renewable energy projects have short construction period compared to conventional energy generation and other infrastructure assets. Renewable projects have limited ramp-up periods, and construction periods of one to three years, compared to 10 years to build while large conventional power plants.
- In several countries, renewable energy producers have been granted priority dispatch. Where in place, grid operators are usually obliged to connect renewable power plants to their grid, and retailers or other authorised entities must purchase all renewable electricity produced.
- Renewable projects present relatively low operational complexity compared to other energy generation assets and other infrastructure asset classes. Onshore wind and solar PV projects in particular have well established operational track records. This is obviously less the case for biomass and offshore wind plants.
- Renewable projects typically have non-recourse financing, through a mix of debt and equity. In contrast to traditional corporate lending, project finance relies on future cash flows for interest and debt repayment, rather than the asset value or the historical financial performance of a company. Project

finance debt typically covers 70–90% of the cost of a project, is non-recourse to the investors, and ideally matches the duration of the underlying contractual agreements.

- Renewable power typically has predictable cash flows and is not subject to fuel price volatility because the primary energy resource is generally free (except for biomass). Contractually guaranteed tariffs along with the moderate cost of building, operating and maintaining renewable generation facilities allow for secure profit margins and predictable cash flows.
- Renewable electricity remuneration mechanisms often include some kind of inflation indexation, although incentive schemes may vary on a case-by-case basis. For example, several tariffs in the EU are indexed to consumer price indices and adjusted on an annual basis (such as in Spain and Italy). In projects where specific inflation protection is not provided (such as in Germany), the regulatory framework allows selling power on the spot market, should the power price be higher than the guaranteed tariff.
- Renewable power plants have expected long useful lives (over 20 years). Transmission lines usually have economic lives of over 40 years. Renewable assets are typically underpinned by long-term contracts with utilities and benefit from governmental support and manufacturer warranties.
- Renewable energy projects deliver attractive and stable sources of income, only loosely linked to the economic cycle. Project owners do not have to manage fuel cost volatility, and projects generate high operating margins with relatively secure revenues and generally limited market risk.

FIGURE 4.1 | RETURN CHARACTERISTICS OF RENEWABLE ENERGIES



source SWISS RE 2011.

### REFERENCES

<sup>1</sup> (SWISS RE 2011), AN INTRODUCTION TO RENEWABLE ENERGY INFRASTRUCTURE INVESTING; CONTACT: ROBERT NEF; CO-HEAD INVESTOR SOLUTIONS; ROBERT\_NEF@SWISSRE.COM; +41 43 285 2121; RENEWABLE ENERGY INFRASTRUCTURE INVESTING - SWISS RE PRIVATE EQUITY PARTNERS; SEPTEMBER 2011;

- The widespread development of renewable power generation will require significant investments in the electricity grid. Future grid (smart grids) will have to integrate an ever-increasing, decentralised, fluctuating supply of renewable energy. Furthermore, suppliers and/or distribution companies will be expected to deliver a sophisticated range of services by embedding digital grid devices into power networks.

Risk assessment and allocation is at the centre of project finance. Accordingly, project structuring and expected return are directly related to the risk profile of the project. The four main risk factors to consider when investing in renewable energy assets are:

**FIGURE 4.2 | OVERVIEW RISK FACTORS FOR RENEWABLE ENERGY PROJECTS**



source SWISS RE 2011.

- *Regulatory risks* refer to adverse changes in laws and regulations, unfavourable tariff setting and changes in and breaches of contracts. However policy security is crucial for all forms of energies and a long-term energy policy stability is the basic fundament for all investments. However, a diversified investment across regulatory jurisdictions, geographies, and technologies can help mitigate those risks.
- *Construction risks* relate to the delayed or costly delivery of an asset, the default of a contracting party, or an engineering/design failure. Construction risks are less prevalent for renewable energy projects because they have relatively simple designs; however, construction risks can be further mitigated by selecting high-quality and experienced turnkey partners, using proven technologies and established equipment suppliers, and agreeing on retentions and construction guarantees
- *Financing risks* refer to the inadequate use of debt in the financial structure of an asset. Examples include the abusive use of leverage, exposure to interest rate volatility, and the need to refinance at less favourable terms.
- *Operational risks* include equipment failure, counterparty default, and reduced availability of the primary energy source (such as wind, heat, and insolation). For renewable assets, lower than forecast resource availability will result in lower revenues and profitability, so this risk can detrimentally impact the business case.

**FIGURE 4.3 | INVESTMENT STAGES OF RENEWABLE ENERGY PROJECTS**



source SWISS RE 2011.

### 4.3 OVERCOMING BARRIERS TO FINANCE AND INVESTMENT FOR RENEWABLE ENERGY

4 Despite the relatively strong growth in renewable energies in an increase number of countries, many barriers still hinder the rapid uptake of renewable energy needed to achieve the

scale of development required. The key barriers to renewable energy investment identified by Greenpeace in a literature review<sup>2</sup> and interviews with renewable energy sector financiers and developers are shown in Figure 4.4.

**TABLE 4.2 | CATEGORISATION OF BARRIERS TO RENEWABLE ENERGY INVESTMENT**

CATEGORY	SUB-CATEGORY	EXAMPLE BARRIERS
BARRIERS TO FINANCE	COST BARRIERS.	COSTS OF RENEWABLE ENERGY TO GENERATE. MARKET FAILURES (NO CARBON PRICE, ETC.). ENERGY PRICES. TECHNICAL BARRIERS. COMPETING TECHNOLOGIES (GAS, NUCLEAR, CCS AND COAL).
	INSUFFICIENT INFORMATION AND EXPERIENCE.	OVERRATED RISKS. LACK OF EXPERIENCED INVESTORS. LACK OF EXPERIENCED PROJECT DEVELOPERS. WEAK FINANCE SECTORS IN SOME COUNTRIES.
	FINANCIAL STRUCTURE.	UP-FRONT INVESTMENT COST. COSTS OF DEBT AND EQUITY. LEVERAGE. RISK LEVELS AND FINANCE HORIZON. EQUITY/CREDIT/BOND OPTIONS. SECURITY FOR INVESTMENT.
	PROJECT AND INDUSTRY SCALE.	RELATIVE SMALL INDUSTRY SCALE. SMALLER PROJECT SCALE.
	INVESTOR CONFIDENCE.	CONFIDENCE IN LONG-TERM POLICY. CONFIDENCE IN SHORT-TERM POLICY. CONFIDENCE IN THE RENEWABLE ENERGY MARKET
OTHER INVESTMENT BARRIERS	GOVERNMENT RE POLICY AND LAW.	FEED-IN TARIFFS. RENEWABLE ENERGY TARGETS. FRAMEWORK LAW STABILITY. LOCAL CONTENT RULES.
	SYSTEM INTEGRATION AND INFRASTRUCTURE.	ACCESS TO GRID. ENERGY INFRASTRUCTURE. OVERALL NATIONAL INFRASTRUCTURE QUALITY. ENERGY MARKET. CONTRACTS BETWEEN GENERATORS AND USERS.
	LOCK IN OF EXISTING TECHNOLOGIES.	SUBSIDIES TO OTHER TECHNOLOGIES. GRID LOCK-IN. SKILLS LOCK-IN. LOBBYING POWER.
	PERMITTING AND PLANNING REGULATION.	FAVOURABILITY. TRANSPARENCY. PUBLIC SUPPORT.
	GOVERNMENT ECONOMIC POSITION AND POLICY.	MONETARY POLICY, SUCH AS INTEREST RATES. FISCAL POLICY, SUCH AS STIMULUS AND AUSTERITY. CURRENCY RISKS. TARIFFS IN INTERNATIONAL TRADE.
	SKILLED HUMAN RESOURCES.	LACK OF TRAINING COURSES.
	NATIONAL GOVERNANCE AND LEGAL SYSTEM.	POLITICAL STABILITY. CORRUPTION. ROBUSTNESS OF LEGAL SYSTEM. LITIGATION RISKS. INTELLECTUAL PROPERTY RIGHTS. INSTITUTIONAL AWARENESS.

source GREENPEACE; OWN RESEARCH 2010-2014.

#### REFERENCES

- 2 SOURCES INCLUDE: INTERGOVERNMENTAL PANEL ON CLIMATE CHANGE (IPCC) (2011) SPECIAL REPORT ON RENEWABLE ENERGY SOURCES AND CLIMATE CHANGE MITIGATION (SRREN), 15TH JUNE 2011.  
UNITED NATIONS ENVIRONMENT PROGRAMME (UNEP), BLOOMBERG NEW ENERGY FINANCE (BNEF) (2015), GLOBAL TRENDS IN RENEWABLE ENERGY INVESTMENT 2015, MARCH 2015.  
RENEWABLE ENERGY POLICY NETWORK FOR THE 21ST CENTURY (REN21) (2015), RENEWABLES 2015, GLOBAL STATUS REPORT, JUNE 2015.  
ECOFYS, FRAUNHOFER ISI, TU VIENNA EEG, ERNST & YOUNG (2011), FINANCING RENEWABLE ENERGY IN THE EUROPEAN ENERGY MARKET BY ORDER OF EUROPEAN COMMISSION, DG ENERGY, 2ND OF JANUARY, 2011.

Broad categories of common barriers to renewable energy development are present in many countries; however, the nature of the barriers differs significantly. At the local level, political and policy support, grid infrastructure, electricity markets and planning regulations have to be negotiated for new projects.

In some regions, policy uncertainty holds back investment more than any absence of policy support mechanisms. In the short term, investors aren't confident rules will remain unaltered or that renewable energy goals will be met in the longer term, let alone increased.

Investor caution about these risks drives up investment costs, and the difficulty in accessing finance is a barrier for renewable energy project developers. The contributing factors include a lack of information and experience among investors and project developers, involvement of smaller companies and projects, and a high proportion of up-front costs.

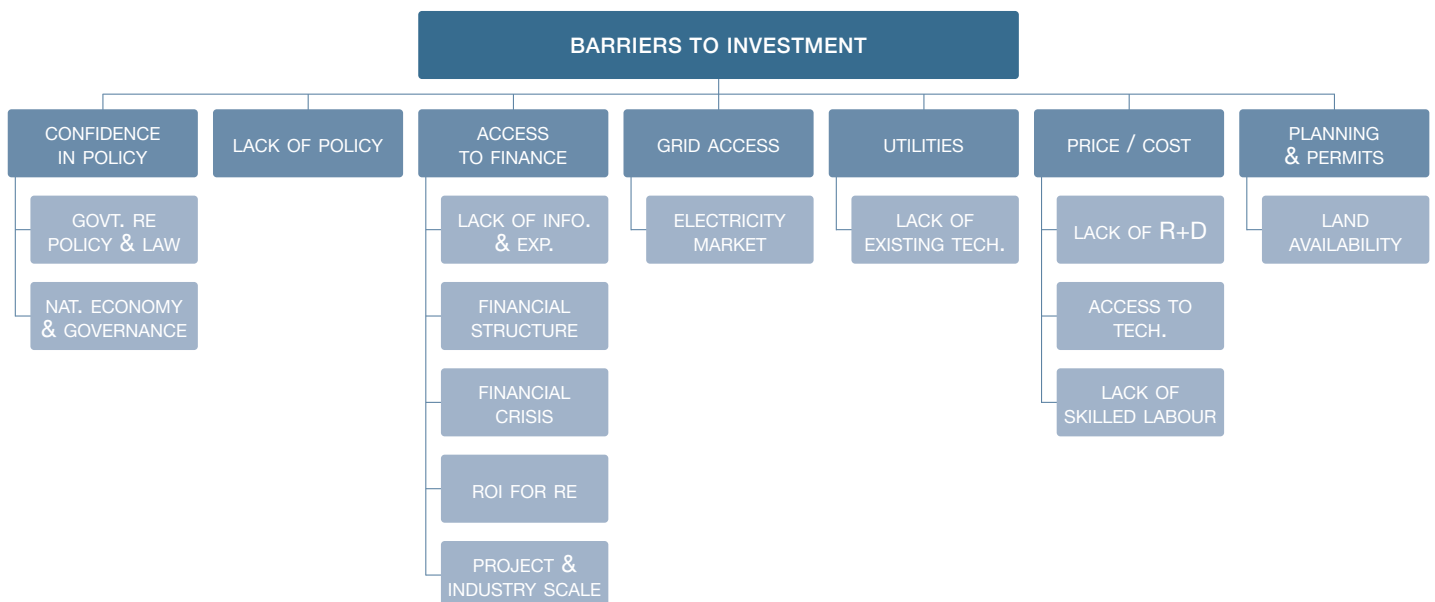
Grid access and grid infrastructure is also a major barrier for developers who, during project development, are not certain they will be able to sell all the electricity they generate in many countries.

In many regions, both state-owned and private utilities block renewable energy with their market and political power, specifically by maintaining the 'status quo' in the grid, protecting electricity markets for centralised coal and nuclear power, and lobbying against pro-renewable and climate protection laws.

The sometimes higher cost of renewable relative to competitors is still a barrier, though many are confident that it will be overcome in the coming decades. The Special Report on Renewable Energy Sources and Climate Change Mitigation (SRREN) identifies cost as the most significant barrier to investment;<sup>3</sup> renewable energy will rely on policy intervention by governments in order to be competitive for some time, which creates additional risks for investors. It is important to note though that in some regions of the world specific renewable technologies are broadly competitive with current market energy prices (such as onshore wind in Europe and solar hot water heaters in China).

Concerns over planning and permit issues are significant, though they vary significantly in their strength and nature depending on the jurisdiction.

FIGURE 4.4 | KEY BARRIERS TO RE INVESTMENT



source SWISS RE 2011.

REFERENCES

3 INTERGOVERNMENTAL PANEL ON CLIMATE CHANGE (IPCC) (2011) SPECIAL REPORT ON RENEWABLE ENERGY SOURCES AND CLIMATE CHANGE MITIGATION (SRREN). 15TH JUNE 2011. CHP. 11, P.24.

#### 4.4 HOW TO OVERCOME INVESTMENT BARRIERS FOR RENEWABLE ENERGY

4 The Energy [R]evolution will require a mix of policy measures, finance, grid, and development. These are dealt with throughout this report, the policy measures in particular in Chapter 13. In summary:

- Additional and improved policy support mechanisms for renewable energy are needed in all countries and regions.
- Building confidence in the existing policy mechanisms may be just as important as making them stronger, particularly in the short term.
- Improved policy mechanisms can also lower the cost of finance, particularly by providing longer durations of revenue support and increasing revenue certainty.<sup>4</sup>
- Access to finance can be increased by greater involvement of governments and development banks in programs like loan guarantees and green bonds as well as more active private investors.
- Grid access and infrastructure needs to be improved through investment in smart, decentralised grids.
- Lowering the cost of renewable energy technologies directly will require industry development and boosted research and development.
- A smoother pathway for renewable energy needs to be established through planning and permit issues at the local level.

#### 4.5 THE FIRST DECADE OF RENEWABLE ENERGY FINANCING

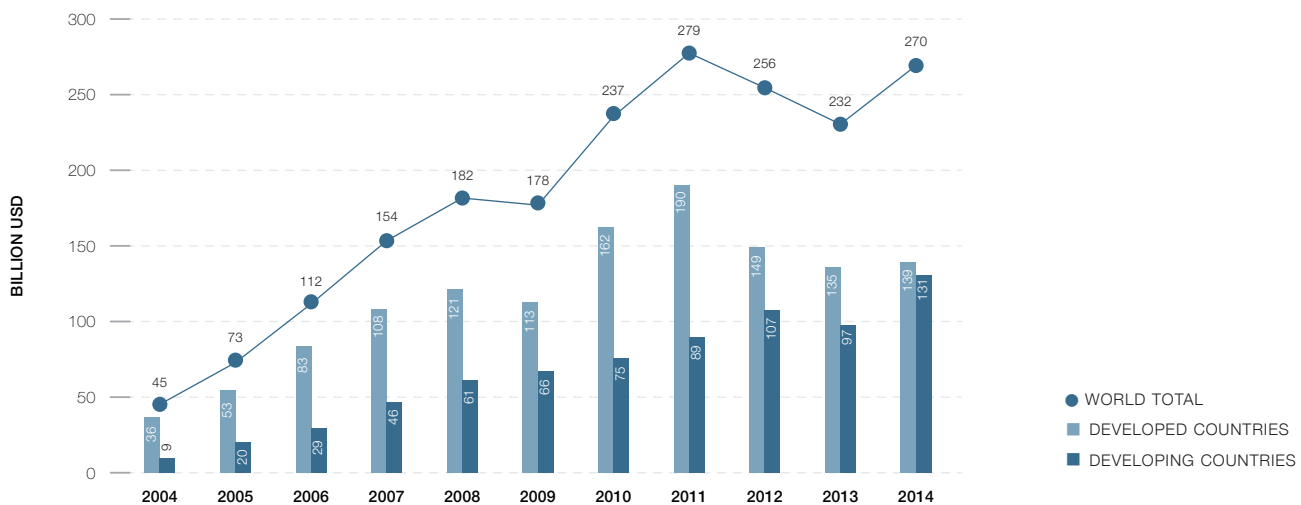
Worldwide, investments in renewable electricity and fuels rose from USD 45 billion in 2004 to USD 270 billion in 2014. But the growth was not constant. The peak was USD 280 billion in 2011. But in 2012, this figure dropped slightly to USD 256 billion and to USD 232 billion in 2013. One reason was policy uncertainty in Europe and the United States along with retroactive changes. This decrease did not, however, reflect far lower global growth; rather, the cost of solar in particular was plummeting. Indeed, though the cost of PV continued to drop, the total investment volume in renewables grew by nearly a fifth in 2014.

For instance, investments in PV dropped by more than a fifth in 2013 compared to the previous year even though new capacity installations grew by nearly a third. In 2014, four more countries – especially in the developing world – began building renewables in light of the falling costs.

The low risk involved in wind and solar power in particular – which have no fuel costs – is increasingly attracting not only commercial banks to the sector, but also pension funds, insurance firms, and corporations outside the energy sector. All of them are looking for stable, long-term returns.

Nonetheless, conventional financing models need to be revised for renewables, which have a relatively high upfront price tag compared to fossil and nuclear power generators. Investment firms are coming up with new tools for this purpose; they go by such names as sustainable yield bonds

FIGURE 4.5 | GLOBAL NEW INVESTMENT IN RENEWABLE POWER AND FUELS, DEVELOPED AND DEVELOPING COUNTRIES, 2004–2014



source REN21 – 2015.

#### REFERENCES

- 4 CLIMATE POLICY INITIATIVE (2011): THE IMPACTS OF POLICY ON THE FINANCING OF RENEWABLE PROJECTS: A CASE STUDY ANALYSIS, 3 OCTOBER 2011.

and green bonds in the US and renewable financing company bonds in the UK. Unconventional funding is also becoming common, such as crowdfunding and community energy co-ops (REN21-2014-B).<sup>5</sup>

4.5.1 INVESTMENT BY ECONOMIC GROUP (REN21 – 2015)<sup>6</sup>

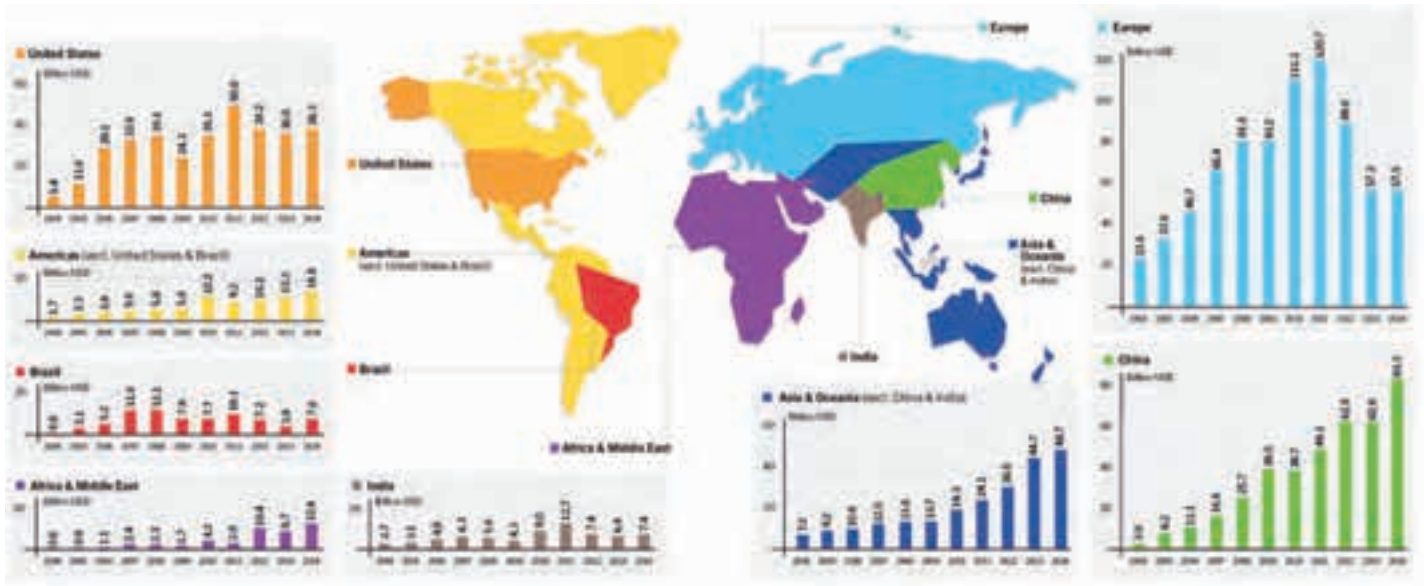
Investments in renewables made in developing countries rose only slightly year-over-year in 2014 by three percent, whereas the growth in developing and emerging countries reached 36 percent, driven largely by China, Brazil, and India. The share of the developing and emerging world and global renewable energy investments therefore reached a new all-time high of 49 percent in 2014, with China making up 63 percent of that share, up only slightly from the previous year. But India's investments grew strongly by 14 percent in 2014. Likewise, other countries in Asia/Oceania continue to post increasing investments, up by nearly 9 percent in 2014 (REN21 2015).

In contrast, investments in Europe were flat that year and only grew in the United States by seven percent. 2011 remains the bumper year for renewable energy investments in these regions. Outside of Brazil and the United States, the Americas posted 21 percent greater investments. The fastest growth, however, came from the Middle East and Africa, where 44 percent more was invested in 2014.

The top 10 list of countries by investment volume was fairly balanced that year, consisting of four BRICS countries and six developed countries. China made up a third of total investments in first place, followed by the United States, Japan, the United Kingdom, Germany, Canada, Brazil, India, the Netherlands, and South Africa.

In tenth place worldwide, South Africa was the leader in Africa. It devoted roughly a third of its investments to wind power in 2014, with just over two thirds going to photovoltaics and CSP. The next largest renewable energy investors in Africa were Kenya, Algeria, Egypt, Nigeria, and Tanzania (REN21 – 2015).

FIGURE 4.6 | GLOBAL NEW INVESTMENT IN RENEWABLE POWER AND FUELS, BY REGION 2001-2014



source REN21 – 2015.

REFERENCES

- 5 (REN21-2014-B); THE FIRST DECADE 2004 – 2014; 10 YEARS OF RENEWABLE ENERGY PROGRESS; REN21; C/O UNEP; 15, RUE DE MILAN, F-75441 PARIS CEDEX 09, FRANCE; OCTOBER 2014; WWW.REN21.NET.
- 6 (REN21 – 2015); RENEWABLES 2015 - GLOBAL STATUS REPORT; ANNUAL REPORTING ON RENEWABLES: TEN YEARS OF EXCELLENCE; REN21; C/O UNEP; 15, RUE DE MILAN, F-75441 PARIS CEDEX 09, FRANCE; JUNE 2015; WWW.REN21.NET

#### 4.5.2 FINANCING MODELS

In 2015, UNEP and Bloomberg New Energy Finance produced an overview of the various methods of collecting funds for renewable energy projects (UNEP-Bloomberg NEF 2015). They include the following:

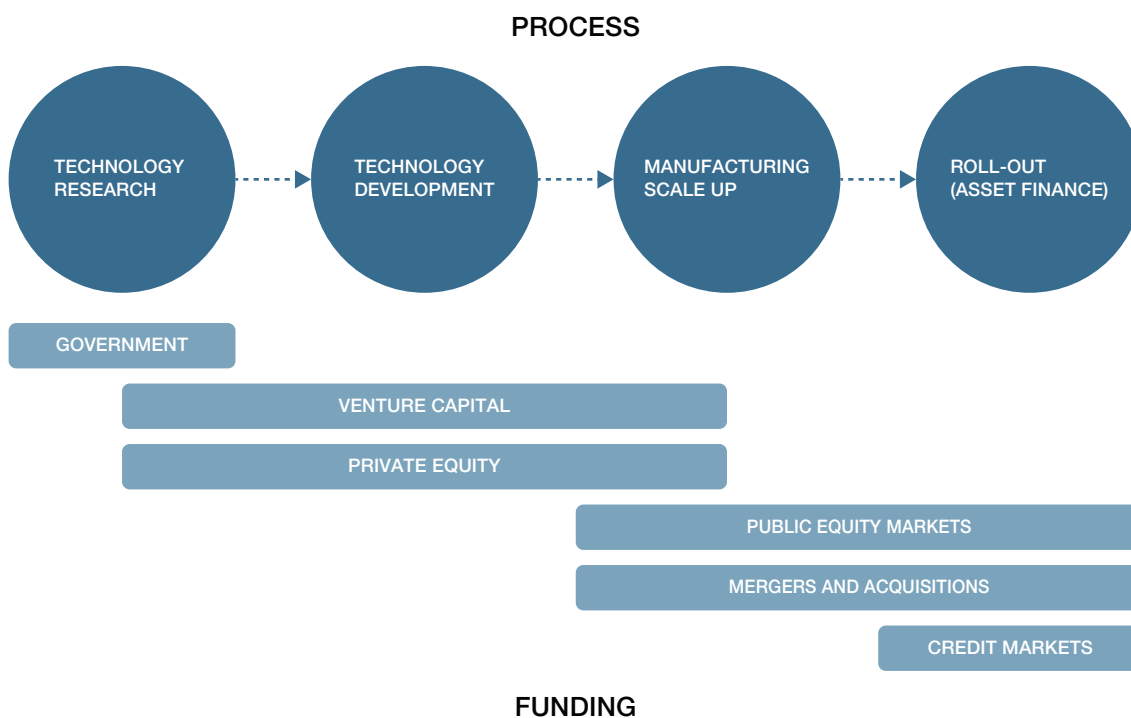
- **Venture capital and private equity (VC/PE):** Venture capital and private equity investments in grew by more than a quarter and 2014 but still remained below the third of the record set in 2008. The United States is still the leader in VC renewable energy investments, whereas equity-raising sector in Europe shrink significantly in 2014 (REN21-2015).
- **Publicly quoted companies:** This sector grew by 42 percent in 2014, making it four times larger than it was in 2012 (REN21-2015). After years of little activity, public markets became interested in small-scale hydropower and ocean energy in 2014. In return, interest in biofuels and biomass dropped and disappeared almost entirely for geothermal, where investments were privatized (REN21-2015).
- **Asset finance,** which includes funds from equity, loans, and corporate balance sheets (but excludes refinancings). Asset financing of utility-scale projects made up 62 percent of total investments in renewable energy in 2014, an increase of 10 percent.

- **Mergers and acquisitions,** where new corporate buyers take over the existing equity and debt of companies developing and/or operating renewable energy projects. These investments shrank by five percent in 2014 as the consolidation phase drew towards an end, both in the wind and solar sectors.

Funding devoted to research and development (R&D) remained relatively flat in 2014, rising by only two percent. This figure includes both governmental and corporate budgets. For the fourth year in a row, more money was invested in solar R&D than all other renewable energy sectors combined. R&D investments in the wind sector fell last year, while they rose slightly for solar at two percent. More funding was devoted, however, to R&D for biofuels, biomass, and ocean energy (REN21-2015). Europe remains a hotspot for renewable energy R&D with more than a third of total investments here – nearly as much as the United States and China combined.

Small-scale distributed renewable energy projects continue to make up a bigger share of the total, however, rising by a third to 27 percent of total investments in 2014. Most of these projects are rooftop photovoltaics (REN21-2015).

FIGURE 4.7 | INVESTMENT CATEGORIES – DEFINITION BY BLOOMBERG NEW ENERGY FINANCE 2015



source UNEP-Bloomberg NEF 2015.



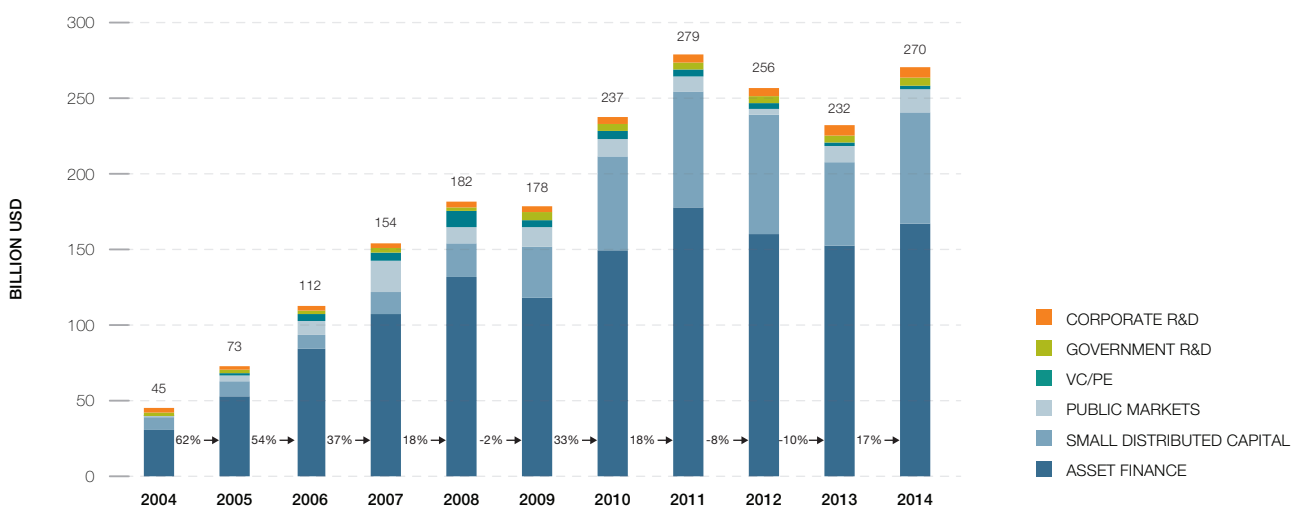
#### 4.5.3 INVESTMENT SOURCES AS OF 2014

Clean energy funds and crowdfunding are the new kids on the financing block. Issues of green bonds hit a record level last year, especially due to a doubling of the volume among development banks, such as the World Bank and national government agencies. For instance, Brazil's BNDES was the leader in utility-scale asset financing, pushing the European Investment Bank into second place. Likewise, corporate green energy bonds grew fivefold.

In 2014, two new South-South development banks were also created: the New Development Bank and the Asian Infrastructure Investment Bank. The five BRICS countries each contributed USD 10 billion to the former, which will go into business in 2016 with a focus on infrastructure and sustainable development. The latter brought together 23 Asian countries (not including Japan and South Korea). It is expected to go into business in late 2015 with an initial budget of USD 50 billion, most of which came from China.

Up to now, it has been commonly assumed that markets would eventually drive renewable energy growth without specific policy support when the cost of renewables is competitive with conventional energy. Now that that point of intersection is being reached, it is becoming clear that policymakers will continue to play a role. As this chapter illustrates, policy will still be needed to facilitate investments. The electrification of the transport sector will also require infrastructure decisions that governments can help make. Likewise, renewable heating and cooling – where the public will make investments as much as energy experts will – requires both awareness-raising and incentives. Finally, as the share of renewable energy increases in power supply, the focus will turn from the cost of a kilowatt-hour from a generator towards overall system costs. Here, policymakers will be needed to ensure that incumbents do not overly protect their stranded investments.

FIGURE 4.8 | GLOBAL NEW INVESTMENT IN RENEWABLE ENERGY BY ASSET CLASS, 2004–14<sup>7</sup>



source UNEP-Bloomberg NEF 2015

#### REFERENCES

<sup>7</sup> (UNEP-BLOOMBERG NEF 2015); GLOBAL TRENDS IN RENEWABLE ENERGY INVESTMENT; 2015; FRANKFURT SCHOOL-UNEP CENTRE/BNEF. 2015. GLOBAL TRENDS IN RENEWABLE ENERGY INVESTMENT 2015, [HTTP://WWW.FS-UNEP-CENTRE.ORG](http://www.fs-unesp-centre.org) (FRANKFURT AM MAIN).

# SCENARIO FOR A FUTURE ENERGY SUPPLY

SCENARIO STORYLINES AND  
MAIN PREMISES

SCENARIO APPROACH AND  
BACKGROUND STUDIES

SCENARIO REGIONS

MAIN SCENARIO ASSUMPTIONS

REVIEW: GREENPEACE SCENARIO  
PROJECTIONS OF THE PAST

5



“

only the most aggressive growth projections such as the greenpeace scenarios has been close to accurate”

© NASA EARTH OBSERVATORY IMAGES BY JESSE ALLEN

**IMAGE** HUNDREDS OF MILLIONS OF TONNES OF SAND AND DUST PARTICLES ARE LIFTED FROM NORTH AFRICAN DESERTS EACH YEAR AND CARRIED ACROSS THE ATLANTIC OCEAN. DUST PICKED UP FROM THE BODÉLÉ DEPRESSION IN CHAD—FARTHER INLAND THAN IN THE STORM SHOWN ABOVE—HAS ROCK MINERALS LOADED WITH PHOSPHORUS, AN ESSENTIAL NUTRIENT FOR PLANT PROTEINS AND GROWTH. THE AMAZON RAINFOREST DEPENDS ON THIS DUST TO FLOURISH BECAUSE SOIL NUTRIENTS ARE IN SHORT SUPPLY IN AMAZONIAN SOILS.

Moving from principles to action for energy supply that mitigates against climate change requires a long-term perspective. Energy infrastructure takes time to build up; new energy technologies take time to develop. Policy shifts often also need many years to take effect. In most world regions the transformation from fossil to renewable energy will require additional investment and higher supply costs over about twenty years. However, there will be tremendous economic benefits in the long term, due to much lower consumption of increasingly expensive, rare or imported fuels. Any analysis that seeks to tackle energy and environmental issues therefore needs to look ahead at least until mid-century.

Scenarios are necessary to describe possible development paths, to give decision-makers a broad overview and indicate how far they can shape the future energy system. Three scenarios are used here to show the wide range of possible pathways in each world region for a future energy supply system:

- a **Reference scenario**, reflecting a continuation of current trends and policies
- the **Energy [R]evolution scenario**, designed to achieve a set of environmental policy targets resulting in an optimistic but still feasible pathway towards a widely decarbonised energy system by 2050 in close relation to basic framework assumptions of the Reference scenario
- the **Advanced Energy [R]evolution scenario**, representing an ambitious pathway towards a fully decarbonised energy system already by 2050 with significant additional efforts compared to the “basic” Energy [R]evolution scenario

## 5.1 SCENARIO STORYLINES AND MAIN PREMISES

The **Reference scenario (REF)** is based on the Current Policies scenarios published by the International Energy Agency (IEA) in *World Energy Outlook 2014 (WEO 2014)*.<sup>1</sup> It only takes into account existing international energy and environmental policies. Its assumptions include, for example, continuing progress in electricity and gas market reforms, the liberalisation of cross-border energy trade and recent policies designed to combat environmental pollution. The Reference scenario does not include additional policies to reduce greenhouse gas emissions. As the IEA's projections only extend to 2040, they are extended by extrapolating their key macroeconomic and energy indicators forward to 2050. This provides a baseline for comparison with the Energy [R]evolution scenarios. Unlike the previous Reference scenario of the Energy [R]evolution study published in 2012, it includes an increase in population and new market trends for renewable technologies.

The **Energy [R]evolution scenario (E[R])** is an update of the Energy [R]evolution scenario published in 2012, which followed the key target to reduce worldwide carbon dioxide emissions from energy use down to a level of around 4 gigatonnes per year by 2050 in order to hold the increase in global temperature under +2°C. A second objective is the global phasing out of nuclear energy. The new Energy [R]evolution scenario takes into account developments between the former base year 2009 and the new base year 2012 as well as changes in the new Reference scenario based on WEO 2014, which serves as the baseline for additional measures assumed in the Energy [R]evolution. In addition, pathways for the deployment of renewable energy and efficiency measures are revised, reflecting technology trends of the last few years and new estimations of worldwide potentials and investment costs leading to partly different technology mixes. Furthermore, the possibilities to implement new technologies by 2020 are now more limited than in 2012 due to the required development time of new power plants and other infrastructures. Following the basic assumptions of the Reference scenario, these changes lead to higher peaks in energy demand and fossil energy supply compared to the Energy [R]evolution of 2012. In consequence, there is a lower decarbonisation pathway if we keep at the previous scenario approach of the Energy [R]evolution. Nevertheless the scenario still includes significant efforts to fully exploit the large potential for energy efficiency, using currently available best-practice technology. At the same time, various proven renewable energy sources are integrated to a large extent for heat and electricity generation as well as the production of biofuels and hydrogen. The general framework parameters for population and GDP growth remain unchanged from the Reference scenario.

The new **Advanced Energy [R]evolution scenario (ADV E[R])** needs much stronger efforts to transform the energy systems of all world regions towards a 100% renewable energy supply. The consumption pathways remain basically the same as in the E[R]; however, a much faster introduction of new technologies leads to a complete decarbonisation of the power, heat and especially the transportation sector. The latter requires a strong role of hydrogen and other synthetic fuels complementary to battery electric vehicle concepts and (limited) biofuels. Due to higher efficiencies of new vehicle concepts and the assumption of much higher modal split changes compared to the basic E[R] resulting final energy demand for transportation is lower. However, this scenario requires more fundamental changes of mobility patterns, behaviour, and infrastructural needs to compensate for the high energy losses associated to the production of synthetic fuels based on renewable electricity. Also in the heating sector, electricity and hydrogen play a larger role substituting remaining fossil fuels. In the power sector, natural gas is replaced by hydrogen as well. Therefore, electricity generation increases significantly in this scenario, assuming power from renewable energy sources to be the main “primary energy” of the future.

## REFERENCES

<sup>1</sup> INTERNATIONAL ENERGY AGENCY, 'WORLD ENERGY OUTLOOK 2014', 2014.

The scenario building follows for both Energy [R]evolution scenarios a framework of targets and main premises that strongly influences the development of individual technological and structural pathways for each region and each sector. The main premises considered for this scenario building process are described in the following.

- Strong efficiency improvements and the dynamic expansion of renewable energy in all sectors are the main strategies to meet the overall target of CO<sub>2</sub> emission reductions. CCS technologies are not implemented, and nuclear power and lignite power plants are phased out quickly, followed by hard coal power plants. In developing countries in particular, a shorter operational lifetime for coal power plants (20 instead of 35 years) is assumed in order to allow a faster uptake of renewable energy. Based on current knowledge about potentials, costs and recent trends in renewable energy deployment (see next section on ‘Scenario approach and background studies’), a dynamic further growth of capacities for renewable heat and power generation is assumed.
- The global quantities of biomass power generators and large hydro power remain limited in the Energy [R]evolution scenarios, for reasons of ecological sustainability. Wind power and solar power (both photovoltaics and concentrating solar power (CSP)) are expected to be the main pillars of future power supply, complemented by smaller contributions from geothermal (hydrothermal and Enhanced Geothermal Systems (EGS)), ocean energy and the further expansion of small and medium sized hydro power. The scenarios follow the strategy to limit the share of fluctuating power generation and to maintain a sufficient share of dispatchable, secured capacity. Therefore, power generation from biomass and CSP but also a sufficient share of gas-fired back-up capacities and storage are important factors for the security of supply in future energy systems.
- Global sustainable biomass potentials are assumed to be limited to less than 100 EJ according to background studies. Traditional biomass use is largely replaced by state-of-the-art technologies, primarily highly efficient cogeneration plants. In developing regions with a high share of traditional biomass use an implementation of improved cooking stoves is assumed. No biomass trade is considered between world regions for the scenarios. However, the large-scale import of electricity from CSP is a promising option for some world regions, especially for OECD Europe, where a net import of up to 400 to 600 TWh per year from North Africa and the Middle East is assumed in the scenarios. CSP implementation after 2030 is assumed for all regions with a solar multiple of 3 and thermal energy storage able to provide energy for 12 h per day of full-load operation of the turbine.
- Efficiency savings in the transport sector are a result of fleet penetration with new highly efficient vehicle concepts, such as electric vehicles but also assumed changes in mobility patterns and the implementation of efficiency measures for combustion engines. Mobility demand is expected to increase strongly in developing countries. The scenarios assume a limited use of biofuels for transportation following the latest scientific reports indicating that biofuels might have a higher greenhouse gas emission footprint than fossil fuels. There are no global sustainability standards for biofuels yet, which would be needed to avoid deforestation and competition with food crops.
- Efficiency in use of electricity and fuels in ‘industry’ and ‘other sectors’ has been re-evaluated based on technical efficiency potentials and energy intensities (see also next section ‘Scenario approach and background studies’). A consistent approach is used to layout feasible, rather conservative pathways and result in converging specific consumptions in all world regions. In consequence, specific energy use for all applications and in all regions is assumed to decrease significantly.
- Hydrogen generated by electrolysis using renewable electricity is introduced as a third renewable fuel in the transportation sector complementary to biofuels and the direct use of renewable electricity. Hydrogen generation can have high energy losses; however, the limited potentials of biofuels and probably also battery electric mobility makes it necessary to have a third renewable option. Alternatively, this renewable hydrogen could be converted into synthetic methane and liquid fuels depending on economic benefits (storage costs vs. additional losses) as well as technology and market development in the transport sector (combustion engines vs. fuel cells). The Advanced Energy [R]evolution scenario takes this strategy one step further, increasing the share of electric and fuel cell vehicles. Additionally, renewable hydrogen is converted into synthetic hydrocarbons, which replace the remaining fossil fuels, especially for heavy duty vehicles and air transportation, albeit with low overall efficiency of the synfuel system.
- The Energy [R]evolution scenarios also foresee a shift in the heat sector towards an increasing direct use of electricity, thanks to the enormous and diverse potential for renewable power and the limited availability of renewable fuels for high temperature process heat in industry. In addition, a fast expansion of the use of district heating and geothermal heat pumps is assumed, leading to an increase in electricity demand, which partly offsets the efficiency savings in these sectors. A faster expansion of solar and geothermal heating systems is also assumed. In the Advanced Energy [R]evolution scenario hydrogen replaces 30-40% of the remaining gas consumption in 2040 and 100% in 2050 – not only for industry, but also for power production in cogeneration and gas power stations, providing back up capacities for variable power production as from wind and PV.

- The increasing shares of fluctuating renewable power generation above all by wind farms and photovoltaics require implicitly the implementation of smart grids and a fast expansion of transmission grids, storage, and other load balancing capacities. Other infrastructural needs result, for instance, from an increasing role of district heating, electric and hydrogen mobility and the generation and distribution of synthetic fuels. In both Energy [R]evolution scenarios, it is therefore implicitly assumed that such infrastructural projects will be implemented in all regions without serious societal, economic and political barriers.
- The scenarios only consider regional demand and supply excluding bunker fuels for international marine shipping and international air transportation. Today, 14% of all fossil transport fuels are used for bunkers. In order to replace bunker fuels entirely with renewables, a combination of energy efficiency and renewable fuels is required. Large-scale biomass use for an additional biofuel generation is possible within the limit of the assumed sustainable biomass potential. However, it's obvious, that - depending on demand development – an additional large-scale generation of synthetic liquid hydrocarbons is necessary for a complete decarbonisation of bunker fuels. We estimate this additional demand in the range of 7,000 to 9,000 PJ of biofuels and synfuels, respectively. The latter would require an additional generation of renewable electricity of about 5,000 to 6,000 TWh per year.

The Energy [R]evolution scenarios by no means claim to predict the future; they simply describe and compare three potential development pathways out of the broad range of possible 'futures'. The Energy [R]evolution scenarios are designed to indicate the efforts and actions required to achieve their ambitious targets and to illustrate the options we have at hand to change our energy supply system into one that is truly sustainable. They may serve as a consistent basis for further analyses of possible ways and concepts to implement the energy transition.

## 5.2 SCENARIO APPROACH AND BACKGROUND STUDIES

The Energy [R]evolution scenarios are target-oriented scenarios. Therefore, they must not be interpreted as a "forecast" of the future development of the energy systems.

### REFERENCES

2. 'ENERGY [R]EVOLUTION: A SUSTAINABLE WORLD ENERGY OUTLOOK', GREENPEACE INTERNATIONAL, 2007, 2008, 2010 AND 2012.
3. ENERGY [R]EVOLUTION: A SUSTAINABLE WORLD ENERGY OUTLOOK', GREENPEACE INTERNATIONAL, 2012.
4. GRAUS, KERMEI 2012: PROJECT REPORT - ENERGY DEMAND PROJECTIONS FOR ENERGY [R]EVOLUTION 2012. UTRECHT UNIVERSITY, MARCH 2012.
5. GLOBAL BIOMASS POTENTIALS - RESOURCES, DRIVERS AND SCENARIO RESULTS, THRÁN, D., SEIDENBERGER, T. ET AL., DBFZ 2010.
6. E.G. REN21 2015: RENEWABLES 2015 - GLOBAL STATUS REPORT; EWEA 2015: THE EUROPEAN OFFSHORE WIND INDUSTRY - KEY TRENDS AND STATISTICS 2014, AND OTHER REGIONAL STATISTICS AND DATA SOURCES.
7. E.G. PIETZCKER, STETTER ET AL. 2014: USING THE SUN TO DECARBONIZE THE POWER SECTOR: THE ECONOMIC POTENTIAL OF PHOTOVOLTAICS AND CONCENTRATING SOLAR POWER, APPLIED ENERGY, VOLUME 135, 15 DECEMBER 2014, PAGES 704–720; DENG ET AL. 2015: QUANTIFYING A REALISTIC, WORLDWIDE WIND AND SOLAR ELECTRICITY SUPPLY, GLOBAL ENVIRONMENTAL CHANGE 31 (2015) 239-252; DLR 2015: REMIX ENDAT MODELLING RESULTS PROVIDED BY THE GERMAN AEROSPACE CENTER, INSTITUTE OF ENGINEERING THERMODYNAMICS.
8. E.G. EPIA 2014: GLOBAL MARKET OUTLOOK FOR SOLAR POWER / 2015-2019.; GWEC 2014: GLOBAL WIND REPORT 2014; WEC 2015: WORLD ENERGY RESOURCES - CHARTING THE UPSURGE IN HYDROPOWER DEVELOPMENT 2015, AND AVAILABLE REGIONAL MARKET DEVELOPMENT PROJECTIONS.

The scenarios are developed using a primarily "bottom-up" approach (technology-driven). Assumed growth rates for population, GDP, specific energy demand and the deployment of renewable energy technology are important drivers. Quantified targets for transforming the energy systems set the framework for their design. The supply scenarios were calculated using the Mesap/PlaNet simulation model adopted in the previous Energy [R]evolution studies.<sup>2</sup> This model does not use a cost optimization approach for the calculation of energy technology expansion rather it requires a consistent exogenous definition of feasible developments in order to meet the targets. Using assumptions and background information about technical and structural options for the transformation of the energy system, and taking into account – as far as possible – possible barriers and limits, consistent development paths are defined and integrated into the model database. The model as accounting framework then calculates the energy balances of the future for all sectors as well as related investments and costs in the power sector.

The scenarios in this report were commissioned by Greenpeace from the Systems Analysis group of the Institute of Engineering Thermodynamics, part of the German Aerospace Center (DLR). The Energy [R]evolution scenarios are based on a series of studies developed for previous Energy [R]evolution versions that are – unless otherwise noted – described in detail in the Energy [R]evolution study of 2012.<sup>3</sup>

Structure and initial parametrization of the energy system for each world region are extracted from the extended energy balances published in 2014 by International Energy Agency (IEA) ('Energy balances of non-OECD countries' and 'Energy balances of OECD countries'). The Reference scenario and related specific data – such as efficiencies, load factors and demand intensities – are based on the Current Policies scenario published by the IEA in World Energy Outlook 2014.

The energy demand projections for the Energy [R]evolution scenarios are also based on a study from the University of Utrecht, Netherlands, analysing the future potential for energy efficiency measures for the Energy [R]evolution 2012 (Graus 2012).<sup>4</sup> New insights on energy demand in developing countries, for instance for Africa from the WEO 2014, and new assumptions about living standards, energy savings and possible rebound effects are included as well.

The biomass potential calculated for previous editions, judged according to Greenpeace sustainability criteria, has been developed by the German Biomass Research Centre in 2009<sup>5</sup> and has been further reduced for precautionary principles. The dynamic expansion of renewable energy defined in the scenarios is based on recent technology trends,<sup>6</sup> current knowledge about regional renewable energy potentials and costs for their deployment<sup>7</sup> and market development projections of the renewable energy industry.<sup>8</sup>

The future development pathway for cars and other transportation technologies is based on a special report produced in 2012 by the Institute of Vehicle Concepts, DLR for Greenpeace International (DLR 2012).<sup>9</sup> The aim was to produce a demanding but feasible scenario to lower global CO<sub>2</sub> emissions from transport in keeping with the overall targets. The approach takes into account a vast range of technical measures to reduce the energy consumption of vehicles, but also considers the dramatic increase in vehicle ownership and annual mileage taking place in developing countries. The major parameters are vehicle technology, alternative fuels, changes in sales of different vehicle sizes of light duty vehicles (called the segment split) and changes in tonne-kilometres and vehicle-kilometres travelled (described as modal split). The Institute carried out new technical research for Greenpeace in early 2015, focusing on the latest developments of land-based transport systems, especially for megacities (DLR 2015).<sup>10</sup>

Assumptions for fossil fuel resources and planned and ongoing investments in coal, gas and oil on a global and regional basis

are based on a study by the Ludwig Bölkow System Technik Institute, commissioned by Greenpeace for the Energy [R]evolution study of 2012. Technology and cost projections for the heating sector are adopted from a background study commissioned by EREC from DLR about the current renewable heating technology markets, market forecasts, cost projections and state of the technology development. Details can be found as well in the Energy [R]evolution study of 2012.

### 5.3 SCENARIO REGIONS

To develop a global energy scenario requires a model that reflects the significant structural differences between different countries' energy supply systems. The International Energy Agency breakdown of ten world regions, as used in the ongoing series of World Energy Outlook reports, has been chosen because the IEA also provides the most comprehensive global energy statistic<sup>11</sup>. This scenario edition maintains the ten regions approach. The countries in each of the world regions are listed in Table 5.1.

TABLE 5.1 | WORLD REGIONS USED IN THE SCENARIOS

REGION	COUNTRIES
OECD EUROPE	Austria, Belgium, Czech Republic, Denmark, Estonia, Finland, France, Germany, Greece, Hungary, Iceland, Ireland, Italy, Israel, <sup>12</sup> Luxembourg, the Netherlands, Norway, Poland, Portugal, Slovak Republic, Slovenia, Spain, Sweden, Switzerland, Turkey, United Kingdom
OECD NORTH AMERICA <sup>13</sup>	Canada, Mexico, United States of America
OECD ASIA OCEANIA	Australia, Japan, Korea (South), New Zealand
EASTERN EUROPE/ EURASIA	Albania, Armenia, Azerbaijan, Belarus, Bosnia-Herzegovina, Bulgaria, Croatia, former Yugoslav Republic of Macedonia, Georgia, Kazakhstan, Kosovo, Kyrgyz Republic, Latvia, Lithuania, Montenegro, Romania, Russia, Serbia, Tajikistan, Turkmenistan, Ukraine, Uzbekistan, Cyprus, Gibraltar and Malta <sup>14</sup>
CHINA	People's Republic of China, including Hong Kong
INDIA	India
OTHER ASIA	Afghanistan, Bangladesh, Bhutan, Brunei Darussalam, Cambodia, Chinese Taipei, Cook Islands, East Timor, Fiji, French Polynesia, Indonesia, Kiribati, Democratic People's Republic of Korea, Laos, Macao, Malaysia, Maldives, Mongolia, Myanmar, Nepal, New Caledonia, Pakistan, Papua New Guinea, Philippines, Samoa, Singapore, Solomon Islands, Sri Lanka, Thailand, Tonga, Vanuatu, Vietnam
LATIN AMERICA <sup>15</sup>	Antigua and Barbuda, Argentina, Aruba, Bahamas, Barbados, Belize, Bermuda, Bolivia, Brazil, British Virgin Islands, Cayman Islands, Chile, Colombia, Costa Rica, Cuba, Dominica, Dominican Republic, Ecuador, El Salvador, Falkland Islands, French Guyana, Grenada, Guadeloupe, Guatemala, Guyana, Haiti, Honduras, Jamaica, Martinique, Montserrat, Netherlands Antilles, Nicaragua, Panama, Paraguay, Peru, St. Kitts and Nevis, Saint Lucia, St. Pierre et Miquelon, St. Vincent and Grenadines, Suriname, Trinidad and Tobago, Turks and Caicos Islands, Uruguay, Venezuela
AFRICA	Algeria, Angola, Benin, Botswana, Burkina Faso, Burundi, Cameroon, Cape Verde, Central African Republic, Chad, Comoros, Congo, Democratic Republic of Congo, Cote d'Ivoire, Djibouti, Egypt, Equatorial Guinea, Eritrea, Ethiopia, Gabon, Gambia, Ghana, Guinea, Guinea-Bissau, Kenya, Lesotho, Liberia, Libya, Madagascar, Malawi, Mali, Mauritania, Mauritius, Morocco, Mozambique, Namibia, Niger, Nigeria, , Rwanda, Sao Tome and Principe, Senegal, Seychelles, Sierra Leone, Somalia, South Africa, South Sudan, Sudan, Swaziland, United Republic of Tanzania, Togo, Tunisia, Uganda, Western Sahara, Zambia, Zimbabwe
MIDDLE EAST	Bahrain, Iran, Iraq, Jordan, Kuwait, Lebanon, Oman, Qatar, Saudi Arabia, Syria, United Arab Emirates, Yemen

#### REFERENCES

9 DLR 2012: PROJECT REPORT - TRANSPORT SCENARIO BUILDING IN THE EJR 2012. PAGENKOPF, J., SCHMID, S., FRIESKE, B., GERMAN AEROSPACE CENTER (DLR), INSTITUTE OF VEHICLE CONCEPTS; STUTTGART, GERMANY.  
10 DLR 2015: PROJECT REPORT - ALTERNATIVE TRANSPORT TECHNOLOGIES FOR MEGACITIES; GERMAN AEROSPACE CENTER (DLR), INSTITUTE OF VEHICLE CONCEPTS; STUTTGART, GERMANY.  
11 'ENERGY BALANCES OF NON-OECD COUNTRIES' AND 'ENERGY BALANCES OF OECD COUNTRIES', IEA, 2014.

12 FOR STATISTICAL REASONS, ISRAEL IS INCLUDED IN OECD EUROPE.  
13 WEO 2014 DEFINES THE REGION „OECD AMERICAS“ AS USA, CANADA, MEXICO, AND CHILE. IN CONTRAST TO THAT THE ENERGY [R]EVOLUTION SCENARIOS CALCULATE CHILE WITH LATIN AMERICA TO MAINTAIN REGIONAL INTEGRITY.  
14 CYPRUS, GIBRALTAR AND MALTA ARE ALLOCATED TO EASTERN EUROPE/EURASIA FOR STATISTICAL REASONS.  
15 LATIN AMERICA INCLUDES CHILE, IN CONTRAST TO WEO 2014.

Regional specifics play an important role for the layout of the scenario pathways.

The **OECD Europe** region includes countries with quite different energy supply systems, potentials of renewable energy sources, as well as power and heat demand patterns. High solar potentials and low heat demand for buildings are characteristic for the south. The northern and western parts of Europe have high wind potentials, especially wind offshore. In northern and central Europe we find high potentials for hydro power and a high energy demand for space heating (as in eastern Europe). Biomass potentials exist predominantly in the north and east and are limited above all in the southern regions. Industrial demand for electricity and process heat is quite different in highly industrialized countries such as Scandinavian countries, Germany or France compared to some eastern and southern countries. In most European countries we already have policies and market mechanisms for the implementation of renewable energy, above all in the EU member countries. The European Network of Transmission System Operators (entso-e) can serve as a well-established basis for the further development of an interconnected European grid, which would be able to implement large-scale and long-range transmission of renewable power to demand centres. This may lead as well to important interconnections to the Middle East/North Africa region and Eastern Europe/Eurasia.

The energy system in **OECD North America** – US, Canada, and Mexico – is dominated by developments in the US, where more than 80% of the region's demand occurs. In the highly developed countries of the US and Canada, reduction of specific energy demand through higher efficiency plays a crucial role for the decarbonisation of OECD North America's energy system. In Mexico, in contrast, increasing living standards and increasing population will result in increasing demand, despite ambitious increases in efficiency. The high potentials for concentrating solar power (CSP) in Mexico and the US will allow for the large-scale use of CSP plants for grid balancing and grid stabilization, reducing the demand for power storages, demand side management and other balancing options compared to other world regions. In the large metropolitan areas in these countries, electromobility and hydrogen cars will penetrate into the market earlier and at a faster pace than in most other world regions.

**OECD Asia Oceania** consists of two islands – Japan and New Zealand – the peninsula South Korea and the continent of Australia. This world region is dominated by the high energy demand in Japan, which has rather limited renewable energy resources. The lack of physical grid connections prevents power transmission between these countries. Thus it is a huge effort to supply the large Japanese nation with renewable energy, and stabilize the fluctuating wind power, without tapping the large solar potential in other countries such as Australia. Hydrogen and synfuels here not only serve for long-term storage of

renewable power, but also as an option for balancing renewable energy supply across borders. An early market introduction of fuel cell cars in Japan may support such a strategy.

The region **Eastern Europe/Eurasia** includes some EU member countries of the East that are not part of the OECD, some other countries of the former Yugoslav Republic and several countries of the former Soviet Union. However, it is dominated by the economy and energy system of Russia. The main energy carrier of today is natural gas followed by oil. The region has large energy resources regarding biomass and wind power but also geothermal energy and photovoltaics. Eastern Europe/Eurasia is the only world region that may face a significant population decrease due to the expected demographic development above all in Russia.

**Latin America** is dominated by the energy system of Brazil, which accounts for around half of the energy demand. Latin America has the highest urbanization rate of all non-OECD regions, providing opportunities for a large-scale electrification of heat and transport sectors based on renewable resources. Biomass potentials in Latin America are high and available for biofuel production. Particularly Brazil already has a long history of biofuel cars on the market. Latin America has also high potentials for photovoltaics and concentrating solar power plants (CSP). According to the WEO 2014 Electricity database,<sup>16</sup> Latin America has a national electrification rate of 95% and an average of 82% in rural areas (year 2012). The WEO 2014 Biomass database<sup>17</sup> shows that a population of 68 million still relied on traditional use of biomass for cooking.

The **Middle East** consists of a series of oil dependent countries, that all share a tremendous solar potential. Transport demand in the Middle East is very high. One reason is the lack of regional rail transportation. There is a high rate of electricity access in urban areas, where currently almost 70% of the fast growing population lives (WEO 2014). Thus, electrification of transport is a main target in the Energy [R]evolution scenarios. For many of the Middle East countries, water scarcity is a problem. Here opportunities arise to combine large concentrating solar power plants with water desalination, reducing pressure on the water supply systems.

**Africa** is a very heterogeneous region, united only by a very fast population growth. It combines arid northern Africa, underdeveloped Sub-Saharan Africa, and the emerging energy market of South Africa. Northern Africa features a high electrification rate, high CSP potential and water scarcity. Sub-Saharan Africa is characterized by a low urbanization and a lack of access to electricity for two-thirds of its people (WEO 2014). The dependency on traditional biomass use is strong, with over 700 million people relying on fuel wood or charcoal for cooking in inefficient cooking stoves or open fires, with an efficiency of 10-20%. An introduction of efficient technologies will scarcely reduce absolute energy demand but will increase living standards. The picture is somewhat different in South Africa, featuring a coal-based energy system and a comparatively stable and well connected electricity grid, with access to electricity for already more than 85% of its population in 2012 (WEO 2014).

#### REFERENCES

- <sup>16</sup> WORLD ENERGY OUTLOOK 2014 – ELECTRICITY ACCESS DATABASE,  
[HTTP://WWW.WORLDENERGYOUTLOOK.ORG/RESOURCES/ENERGYDEVELOPMENT/ENERGYACCESSDATABASE/](http://www.worldenergyoutlook.org/resources/energydevelopment/energyaccessdatabase/)  
<sup>17</sup> WORLD ENERGY OUTLOOK 2014 – TRADITIONAL USE OF SOLID BIOMASS FOR COOKING,  
[HTTP://WWW.WORLDENERGYOUTLOOK.ORG/RESOURCES/ENERGYDEVELOPMENT/ENERGYACCESSDATABASE/](http://www.worldenergyoutlook.org/resources/energydevelopment/energyaccessdatabase/)

India has a fast-growing population of over 1.2 billion people and is the seventh-largest country by area. However, population density is already 2.7 times higher than in China. Due to its climate, India has a rather limited CSP potential. Wind power potential is expected to be limited due to land use constraints; however, a large technical potential can be estimated from available meteorological data. According to the WEO 2014 database, electricity access is on average 75%, with 94% in urban areas and 67% in rural areas. In India, about 815 million people still relied on the traditional use of biomass for cooking in 2012. Due to population and GDP growth, increasing living standards, and mobility, it is expected that final energy demand in India will further increase significantly, although large potentials for efficiency savings exist.

China has large potentials for renewable energy resources, especially for solar thermal power generation in the west, wind onshore in the north and wind offshore in the east and southeast. Photovoltaic power generation could play an important role throughout all regions. Expansion of hydropower generation is currently also seen a major strategy; however, potentials for small hydro are rather low. China will face further large increases in energy demand in all sectors of the energy system. Chinese economic prosperity has been underpinned mainly by coal, which provides over two-thirds of China's primary energy supply today (IEA WEO 2014). The increase in electricity use due to higher electrification rates will be a major factor for the successful expansion of renewable energy in the industry, buildings and transportation sectors. In China, nearly all households are connected to the electricity grid. But according to WEO 2014, about 450 million Chinese still relied on the traditional use of biomass for cooking in 2012. China has pledged to curtail CO<sub>2</sub> emissions before 2030 and has already some ambitious political targets for renewable energy deployment.

The **Other Asia** region includes all developing countries of Asia except China and India. This group covers a large spectrum in terms of size, economy, stability, development status and a large spread geographically from the Arabian Sea into the Pacific. Electricity access is quite different in these countries as well according to WEO 2014. In southeast Asia, we find an average access of 77 %, with only one third of population in Myanmar and Cambodia and nearly 100% access in Singapore, Thailand and Vietnam. In Indonesia, we find 76% (92% in urban areas), in Bangladesh 60% (90%), and in Pakistan 69% (88%). In southeast Asia, 46% of the population still relies on traditional biomass use with the highest shares in Myanmar (93%) and Cambodia (89%). In Indonesia, 42%, in Bangladesh 89% and in Pakistan 62% still used biomass for cooking in 2012. The lowest values can be found in Singapore (0%), Malaysia (0%) and Thailand (24%). The scenarios thus cover the whole band width of renewable sources and technological development, even though the outlook for each country might deviate largely from the average.

## 5.4 MAIN SCENARIO ASSUMPTIONS

### 5.4.1 POPULATION DEVELOPMENT

Future population development is an important factor in energy scenario building because population size affects the size and composition of energy demand, directly and through its impact on economic growth and development. The IEA World Energy Outlook 2014 uses the United Nations Development Programme (UNDP) projections for population development. For this study the same population projections from UNDP up to 2050 are applied.<sup>18</sup>

Table 5.2 shows that, based on UNEP World Population Prospect 2012 (medium fertility variant), the world's population is expected to grow by 0.8 % per year on average over the period 2015 to 2050, from 7.3 billion people in 2009 to nearly 9.5 billion by 2050. The rate of population growth will slow over the projection period, from 1.1% per year during 2012-2020 to 0.6% per year during 2040-2050. The updated projections show an increase in population estimates by 2050 of around 250 million compared to the UNDP 2010 edition, which was used for the Energy [R]evolution 2012. From a regional perspective, the population of the developing regions will continue to grow most rapidly. The region Eastern Europe/Eurasia will face a continuous decline (7% in total between 2012 and 2050), followed after a short while by the OECD Asia Oceania countries and also China. The population in OECD Europe and OECD North America are expected to increase through 2050. The share of the population living in today's non-OECD countries will increase from the current 82% to 85% in 2050. China's contribution to world population will drop from 20% today to 15% in 2050. Africa will remain the region with the highest growth rate, leading to a share of 25% of world population in 2050.

Satisfying the energy needs of a growing population in the developing regions of the world in an environmentally friendly manner is the fundamental challenge to achieve a global sustainable energy supply.

#### REFERENCES

<sup>18</sup> WORLD POPULATION PROSPECTS: THE 2012 REVISION (MEDIUM VARIANT)', UNITED NATIONS, POPULATION DIVISION, DEPARTMENT OF ECONOMIC AND SOCIAL AFFAIRS (UNDP), 2013.



**TABLE 5.2 | POPULATION DEVELOPMENT PROJECTIONS**

MILLION PEOPLE

	2012	2020	2025	2030	2040	2050
WORLD	7,080	7,717	8,083	8,425	9,039	9,551
OECD EUROPE	564	580	588	594	602	604
OECD NORTH AMERICA	477	512	532	551	582	606
OECD ASIA OCEANIA	204	206	207	206	203	199
EASTERN EUROPE/EURASIA	341	341	339	335	326	316
INDIA	1,237	1,353	1,419	1,476	1,566	1,620
CHINA	1,384	1,440	1,457	1,461	1,444	1,393
OTHER ASIA	1,086	1,193	1,254	1,308	1,395	1,449
LATIN AMERICA	485	526	549	569	601	622
AFRICA	1,084	1,312	1,468	1,634	1,999	2,393
MIDDLE EAST	218	253	272	289	322	349

source UN World Population Prospects - 2012 Revision, medium variant.

**TABLE 5.3 | GDP DEVELOPMENT PROJECTIONS - AVERAGE ANNUAL GROWTH RATES**

	2012-2025	2025-2040	2040-2050	2012-2050
WORLD	3.4%	3.4%	2.2%	3.1%
OECD EUROPE	1.9%	1.6%	1.0%	1.5%
OECD NORTH AMERICA	2.2%	2.3%	1.2%	2.0%
OECD ASIA OCEANIA	1.8%	1.5%	0.5%	1.3%
EASTERN EUROPE/EURASIA	3.5%	2.6%	1.9%	2.7%
INDIA	6.6%	5.5%	3.1%	5.2%
CHINA	5.3%	4.7%	2.7%	4.4%
OTHER ASIA	4.5%	4.5%	3.0%	4.0%
LATIN AMERICA	3.5%	3.0%	2.2%	2.9%
AFRICA	4.8%	4.7%	4.2%	4.6%
MIDDLE EAST	3.9%	3.4%	3.2%	3.5%

source GEA 2012-2040: IEA (2011a) and 2040-2050: DLR, own calculation (2015).

#### 5.4.2 ECONOMIC GROWTH

Economic growth is a key driver for energy demand. Since 1971, each 1% increase in global Gross Domestic Product (GDP) has been accompanied by a 0.6% increase in primary energy consumption. The decoupling of energy demand and GDP growth is therefore a prerequisite for an Energy [R]evolution. Most global energy/economic/environmental models constructed in the past have relied on market exchange rates to place countries in a common currency for estimation and calibration. This approach has been the subject of considerable discussion in recent years, and an alternative has been proposed in the form of purchasing power parity (PPP) exchange rates. Purchasing power parities compare the costs in different currencies of a fixed basket of traded and non-traded goods and services and yield a widely-based measure of the standard of living. This is important in analysing the main drivers of energy demand or for comparing energy intensities among countries.

Although PPP assessments are still relatively imprecise compared to statistics based on national income and product trade and national price indexes, they are considered to provide a better basis for global scenario development.<sup>19</sup> Thus all data on economic development in WEO 2014 refers to purchasing power adjusted GDP. However, as WEO 2014 only covers the time period up to 2040 projections for 2040-2050 for the Energy [R]evolution scenarios are based on our own estimates.

Prospects for GDP growth have decreased considerably since the previous study, due to the financial crisis at the beginning of 2009, although underlying growth trends continue much the same. GDP growth in all regions is expected to slow gradually over the coming decades. World GDP is assumed to grow on average by 3.4% per year over the period 2012-2040. China and India are expected to grow faster than other regions, followed by the Middle East, Africa, other non-OECD Asia, and Eastern Europe/Eurasia. The growth of the Chinese economy will slow as it becomes more mature, but it will nonetheless become the largest in the world in PPP terms by 2030. GDP in OECD Europe and OECD Asia Oceania is assumed to grow by around 1.5% and 1.3% per year over the projection period, while economic growth in OECD North America is expected to be slightly higher. The OECD share of global PPP-adjusted GDP will decrease from 53% in 2012 to 32% in 2050.

#### REFERENCES

<sup>19</sup> NORDHAUS, W., "ALTERNATIVE MEASURES OF OUTPUT IN GLOBAL ECONOMIC-ENVIRONMENTAL MODELS: PURCHASING POWER PARITY OR MARKET EXCHANGE RATES?"; REPORT PREPARED FOR IPCC EXPERT MEETING ON EMISSION SCENARIOS, US-EPA WASHINGTON DC, JANUARY 12-14, 2005.

### 5.4.3 OIL AND GAS PRICE PROJECTIONS

The recent dramatic fluctuations in global oil prices have been significant and with influence on price projections. Under the 2004 'high oil and gas price' scenario from the European Commission, for example, an oil price of just \$34 per barrel was assumed in 2030. More recent projections of oil prices by 2040 in the IEA's WEO 2014 range from \$<sub>2013</sub>100/bbl in the 450 ppm scenario up to \$<sub>2013</sub>155/bbl in the Current Policies scenario.

Since the first Energy [R]evolution study was published in 2007, the actual price of oil has moved over \$100/bbl for the first time, and in July 2008 reached a record high of more than \$140/bbl. Oil prices then fell back to \$100/bbl in September 2008 and around \$80/bbl in April 2010, but

afterwards again increased to more than \$110/bbl in early 2012. Beginning in 2014, oil prices plummeted to values between 40 and 60 \$/bbl in 2015 due to the global economic situation and market reasons. Taking into account expected growth in global energy demand in mid-term and long-term projections, the 2015 revision of the Energy [R]evolution scenarios assumed fossil fuel price projections according to the World Energy Outlook 2014. In contrast to the previous Energy [R]evolution editions, the result is different assumptions for the Reference scenario compared to the Energy [R]evolution scenarios.

As the supply of natural gas is limited by the availability of pipeline infrastructure, there is no world market price for gas. In most regions of the world the gas price is directly tied to the price of oil.

**TABLE 5.4 | DEVELOPMENT PROJECTIONS FOR FOSSIL FUEL AND BIOMASS PRICES IN \$2010**

	UNIT	2000	2005	2007	2008	2010	2012/ 2013	2020	2025	2030	2035	2040	2050
<b>CRUDE OIL IMPORTS</b>													
HISTORIC PRICES (FROM WEO)	\$2013/BARREL	37,1	54,1	81,2	105,2	83,6	106,0						
REFERENCE SCENARIO ACCORDING TO WEO 2014, CURRENT POLICIES SCENARIO	\$2013/BARREL						106,0	116,0	127,5	139,0	147,0	155,0	155,0
ENERGY [R]EVOLUTION SCENARIOS ACCORDING TO WEO 2014, 450 PPM SCENARIO	\$2013/BARREL						106,0	105,0	103,5	102,0	101,0	100,0	98,0
<b>NATURAL GAS IMPORTS</b>													
HISTORIC PRICES (FROM WEO)													
UNITED STATES	\$2013/GJ	5,4	2,5	3,5	9,4	5,0	3,9						
EUROPE	\$2013/GJ	4,0	4,9	6,8	11,8	8,5	11,2						
JAPAN LNG	\$2013/GJ	6,6	4,9	6,9	14,4	12,4	17,1						
REFERENCE SCENARIO ACCORDING TO WEO 2014, CURRENT POLICIES SCENARIO													
UNITED STATES							3,9	5,8	6,5	7,2	8,1	9,0	10,8
EUROPE	\$2013/GJ						11,2	12,1	13,0	13,9	14,3	14,8	15,6
JAPAN LNG	\$2013/GJ						17,1	15,8	16,5	17,2	17,7	18,3	19,3
ENERGY [R]EVOLUTION SCENARIOS ACCORDING TO WEO 2014, 450 PPM SCENARIO													
UNITED STATES	\$2013/GJ						3,9	5,4	5,8	6,2	6,3	6,4	6,6
EUROPE	\$2013/GJ						11,2	11,1	10,8	10,6	10,1	9,7	8,9
JAPAN LNG	\$2013/GJ						17,1	14,3	13,8	13,3	13,0	12,7	12,0
<b>OECD STEAM COAL IMPORTS</b>													
HISTORIC PRICES (FROM WEO)	\$2013/GJ	1,9	2,3	3,3	5,7	4,6	3,7						
REFERENCE SCENARIO ACCORDING TO WEO 2014, CURRENT POLICIES SCENARIO	\$2013/GJ						3,7	4,6	4,9	5,1	5,2	5,4	5,7
ENERGY [R]EVOLUTION SCENARIOS ACCORDING TO WEO 2014, 450 PPM SCENARIO	\$2013/GJ						3,7	3,8	3,6	3,4	3,4	3,3	3,3
<b>SOLID BIOMASS</b>													
REFERENCE AND ENERGY [R]EVOLUTION SCENARIOS	\$2013/GJ						4,2	4,6	4,9	5,2	5,4	5,7	6,3
<b>NUCLEAR FUEL</b>													
REFERENCE AND ENERGY [R]EVOLUTION SCENARIOS	\$2013/GJ						1,0	1,3	1,4	1,6	1,7	1,9	2,3

source IEA WEO 2014 and own assumptions.

#### 5.4.4 COST PROJECTIONS FOR EFFICIENT FOSSIL FUEL GENERATION AND CARBON CAPTURE AND STORAGE (CCS) AND CO<sub>2</sub> EMISSIONS

Specific investment and operation costs of coal, gas, lignite and oil power plants are assumed according to WEO 2014 Special report on investments.<sup>20</sup> Because they are at an advanced stage of technology and market development, the potential for cost reductions is limited.

There is much speculation about the potential for carbon capture and storage (CCS) to mitigate the effect of fossil fuel consumption on climate change, even though the technology is still under development. Assumptions about costs, effectiveness and environmental effects of CCS are highly speculative, therefore CCS power plants are not included in the Energy [R]evolution analysis. More details can be found in the previous Energy [R]evolution edition of 2012.

Prospects for establishing an effective global carbon emissions trading system across all world regions are currently at best unclear. In contrast to the previous Energy [R]evolution scenario, the 2015 revision sets aside CO<sub>2</sub> pricing altogether. Cost comparisons between the scenarios thus only rely on investment, operation & maintenance and fuel costs.

Table 5.5 summarises our assumptions on the technical and economic parameters of future fossil-fuelled power plant technologies. Based on estimates from WEO 2014, we assume that further technical innovation will not prevent an increase of future investment costs because raw material costs and technical complexity will continue to increase. Also, improvements in power plant efficiency are outweighed by the expected increase in fossil fuel prices, in which would make electricity generation costs increase significantly.

#### 5.4.5 COST PROJECTIONS FOR RENEWABLE ENERGY TECHNOLOGIES

The different renewable energy technologies available today all have different technical maturity, costs and development potential. Whereas hydro power has been widely used for decades, other technologies, such as the gasification of biomass or ocean energy, have yet to find their way to market maturity. Some renewable sources by their very nature, including wind and solar power, provide a variable supply, requiring a revised coordination with the grid network. But although in many cases renewable energy technologies are 'distributed' - their output being generated and delivered locally to the consumer - in the future we can also have large-scale applications like offshore wind parks, photovoltaic power plants or concentrating solar power stations.

**TABLE 5.5 | DEVELOPMENT OF EFFICIENCY AND INVESTMENT COSTS FOR SELECTED NEW POWER PLANT TECHNOLOGIES; EXEMPLARY DATA FOR OECD EUROPE**

	2010	2020	2030	2040	2050
<b>COAL FIRED CONDENSING POWER PLANT</b>					
EFFICIENCY (%)	43	44	45	47	49
INVESTMENT COSTS (\$2012/kW)	2,000	2,000	2,000	2,000	2,000
<b>LIGNITE FIRED CONDENSING POWER PLANT</b>					
EFFICIENCY (%)	41	43	44	45	45
INVESTMENT COSTS (\$2012/kW)	2,200	2,200	2,200	2,200	2,200
<b>GAS TURBINE</b>					
EFFICIENCY (%)	39	40	40	41	42
INVESTMENT COSTS (\$2012/kW)	500	500	500	500	500
<b>GAS FIRED COMBINED CYCLE POWER PLANT</b>					
EFFICIENCY (%)	60	61	62	63	64
INVESTMENT COSTS (\$2012/kW)	1,000	1,000	1,000	1,000	1,000
<b>GAS FIRED COMBINED CYCLE CHP PLANT</b>					
EFFICIENCY (%)	83	84	85	86	88
INVESTMENT COSTS (\$2012/kW)	1,300	1,300	1,300	1,300	1,300

source Based on WEO 2014 and own assumptions.

note CO<sub>2</sub> emissions refer to power station outputs only; life-cycle emissions are not considered.

#### REFERENCES

<sup>20</sup> IEA 2014: POWER GENERATION IN THE NEW POLICIES AND 450 SCENARIOS - ASSUMED INVESTMENT COSTS, OPERATION AND MAINTENANCE COSTS AND EFFICIENCIES IN THE IEA WORLD ENERGY INVESTMENT OUTLOOK 2014, DATA FILE  
DOWNLOAD: [HTTP://WWW.WORLDENERGYOUTLOOK.ORG/INVESTMENT/](http://www.worldenergyoutlook.org/investment/)

It is possible to develop a wide spectrum of options to market maturity, using the individual advantages of the different technologies, linking them with each other, and integrating them step by step into the existing supply structures. This approach will provide a complementary portfolio of environmentally friendly technologies for heat and power supply and the provision of transport fuels.

Many of the renewable technologies employed today are at a relatively early stage of market development. As a result, the costs of electricity, heat and fuel production are generally higher than those of competing conventional systems - a reminder that the environmental and social costs of conventional power production are not reflected in market prices. It is expected, however that large cost reductions can come from technical advances, manufacturing improvements and large-scale production, unlike conventional technologies. The dynamic trend of cost developments over time plays a crucial role in identifying economically sensible expansion strategies for scenarios spanning several decades.

To identify long-term cost developments, learning curves have been applied to the model calculations to reflect the how cost of a particular technology change in relation to the cumulative production volumes. For many technologies, the learning factor (or progress ratio) is between 0.75 for less mature systems to 0.95 and higher for well-established technologies. A learning factor of 0.9 means that costs are expected to fall by 10% every time the cumulative output from the technology doubles. Empirical data shows, for example, that the learning factor for PV solar modules has been fairly constant at 0.8 over 30 years whilst that for wind energy varies from 0.75 in the UK to 0.94 in the German market.

Assumptions on future costs for renewable electricity technologies in the Energy [R]evolution scenario of 2012 were derived from a review of learning curve studies, for example by Lena Neij,<sup>21</sup> from the analysis of technology foresight and road mapping studies, including the European Commission funded NEEDS project (New Energy Externalities Developments for Sustainability)<sup>22</sup> or the IEA Energy Technology Perspectives 2008, projections by the European Renewable Energy Council published in April 2010 ("Re-Thinking 2050") and discussions with experts from different sectors of the renewable energy industry. For the new Energy [R]evolution, cost decreases due to recent market developments are taken into account, leading to changes in own cost assumptions above all for photovoltaics and solar thermal power plants (including heat storages). However, for the reason of consistency, region-specific cost assumptions from WEO 2014 are adopted for biomass power plants, hydro, wind power and ocean energy. The following tables exemplarily show data used for the region OECD Europe.

## Photovoltaics

The worldwide photovoltaics (PV) market has been growing at 25% per annum in recent years, reaching 40 GW of new installed capacity in 2014<sup>23</sup> and is starting to make a significant contribution to electricity generation. Photovoltaics are important because of its decentralised/centralised character, its flexibility for use in an urban environment and huge potential for cost reduction. The PV industry has been increasingly exploiting this potential during the last few years, with installation prices more than halving in the last few years. Current development is focused on improving existing modules and system components by increasing their energy efficiency and reducing material usage. Technologies like PV thin film (using alternative semiconductor materials) or dye sensitive solar cells are developing quickly and present a huge potential for cost reduction. The mature technology crystalline silicon, with a proven lifetime of 30 years, is continually increasing its cell and module efficiency (by 0.5% annually), whereas the cell thickness is rapidly decreasing (from 230 to 180 microns over the last five years). Commercial module efficiency varies from 14 to 21%, depending on silicon quality and fabrication process.

The learning factor for PV modules has been fairly constant over the last 30 years with costs reducing by 20% each time the installed capacity doubles, indicating a high rate of technical learning. Assuming a globally installed capacity of 5,000 to 7,000 GW between 2040 and 2050 in the Energy [R]evolution scenario, and with an electricity output of 7,000 to 10,000 TWh/a, we can expect that generation costs of around 4-7 cents/kWh (depending on the region) will be achieved. PV has already become competitive with retail electricity prices in some parts of the world, and will become competitive with fossil fuel costs soon.

TABLE 5.6 | PHOTOVOLTAICS (PV) COST ASSUMPTIONS

	UNIT	2012	2020	2030	2040	2050
<b>PV POWER PLANT</b>						
INVESTMENT COSTS	\$/kWp	2,350	1,550	1,160	920	680
O & M COSTS	\$/kW · a)	24	16	12	9	7

## REFERENCES

<sup>21</sup> NEIJ, L. 'COST DEVELOPMENT OF FUTURE TECHNOLOGIES FOR POWER GENERATION - A STUDY BASED ON EXPERIENCE CURVES AND COMPLEMENTARY BOTTOM-UP ASSESSMENTS', ENERGY POLICY 36 (2008), 2200-2211.

<sup>22</sup> WWW.NEEDS-PROJECT.ORG

<sup>23</sup> EPIA 2014: GLOBAL MARKET OUTLOOK FOR SOLAR POWER / 2015 - 2019.

### Concentrating Solar Power (CSP)

'Concentrating' solar thermal power stations can only use direct sunlight and therefore depend on very sunny locations. North Africa, for example, has a technical potential for this technology which far exceeds local demand. The various solar thermal technologies (detailed in Chapter 10) have good prospects for further development and cost reductions. Because of their more simple design, 'Fresnel' collectors are considered as an option for additional cost trimming. The efficiency of central receiver systems can be increased by producing compressed air at a temperature of up to 1,000 C°, which is then used to run a combined gas and steam turbine.

Thermal storage systems are a way for CSP electricity generators to reduce costs and to provide flexible and dispatchable capacity. The Spanish Andasol 1 plant, for example, is equipped with molten salt storage with a capacity of 7.5 hours. A higher level of full load operation can be realised by using a thermal storage system and a larger collector field. Although this leads to higher investment costs, it reduces the cost of electricity generation.

Depending on the level of irradiation and mode of operation, it is expected that long term future electricity generation costs of 7-10 cents/kWh can be achieved. This presupposes rapid market introduction in the next few years.

### Wind power

Within a short period of time, the dynamic development of wind power has resulted in the establishment of a flourishing global market of over 50 GW in 2014.<sup>24</sup> In Europe, favourable policy incentives were the early drivers for the global wind market. However, since 2009 more than three quarters of the annual capacity installed was outside Europe and this trend is

likely to continue. The boom in demand for wind power technology has nonetheless led to supply constraints and stagnating markets. As a consequence, the cost of new systems has increased. The industry is continuously expanding production capacity, however, so it is already resolving the bottlenecks in the supply chain and in 2014 market development again gained speed and increased by 6-10 GW compared to the years before. Taking into account market development projections, learning curve analysis and industry expectations, investment costs for wind turbines are reduced in the scenario by 13% for onshore and 47% for offshore installations up to 2050.

### Biomass

The crucial factor for the economics of using biomass for energy is the cost of the feedstock, which today ranges from a negative for waste wood (based on credit for waste disposal costs avoided) through inexpensive residual materials to the more expensive energy crops. The resulting spectrum of energy generation costs is correspondingly broad. One of the most economic options is the use of waste wood in steam turbine combined heat and power (CHP) plants. Gasification of solid biomass, on the other hand, which has a wide range of applications, is still relatively expensive. In the long term it is expected that using wood gas both in micro CHP units (engines and fuel cells) and in gas-and-steam power plants will have the most favourable electricity production costs. Converting crops into ethanol and 'bio diesel' made from rapeseed methyl ester (RME) has become increasingly important in recent years, for example in Brazil, the USA and Europe – although its climate benefit is disputed. Processes for obtaining synthetic fuels from biogenic synthesis gases will also play a larger role.

TABLE 5.7 | CSP COST ASSUMPTIONS

	UNIT	2012	2020	2030	2040	2050
<b>SOLAR THERMAL POWER PLANT</b>						
INVESTMENT COSTS	\$/kWp	7,250	5,880	5,430	5,070	4,940
O & M COSTS	\$(/kW · a)	290	235	217	203	198

note Including costs for an increasing solar multiple up to 3 and thermal energy storage suitable for up to 12 h per day full load operation of the turbine.

TABLE 5.8 | WIND COST ASSUMPTIONS

	UNIT	2012	2020	2030	2040	2050
<b>WIND TURBINE ONSHORE</b>						
INVESTMENT COSTS	\$/kWp	1,790	1,700	1,650	1,610	1,570
O & M COSTS	\$(/kW · a)	46	43	42	41	40
<b>WIND TURBINE OFFSHORE</b>						
INVESTMENT COSTS	\$/kWp	5,180	4,000	3,540	3,100	2,750
O & M COSTS	\$(/kW · a)	181	140	124	108	96

### REFERENCES

A large potential for exploiting modern technologies exists in Latin and North America, Europe and Eastern Europe/Eurasia, either in stationary appliances or the transport sector. In the long term, Europe and Eastern Europe/Eurasia could realise 20-50% of the potential for biomass from energy crops, whilst biomass use in all the other regions will have to rely on forest residues, industrial wood waste and straw. In Latin America, North America and Africa in particular an increasing residue potential will be available.

In other regions, such as the Middle East and all Asian regions, increased use of biomass is restricted, either due to a generally low availability or already high traditional use. For the latter, using modern, more efficient technologies will improve the sustainability of current usage and have positive side effects, such as reducing indoor pollution and the heavy workloads currently associated with traditional biomass use.

### Geothermal

Geothermal energy has long been used worldwide for supplying heat, and since the beginning of the last century for electricity generation. Geothermally generated electricity was previously limited to sites with specific geological conditions, but further intensive research and development work widened potential sites. In particular the creation of large underground heat exchange surfaces - Enhanced Geothermal Systems (EGS) - and the improvement of low temperature power conversion, for example with the Organic Rankine Cycle, could make it possible to produce geothermal electricity anywhere. Advanced heat and power cogeneration plants will also improve the economics of geothermal electricity.

A large part of the costs for a geothermal power plant come from deep underground drilling, so further development of innovative drilling technology is expected. Assuming a global average market growth for geothermal power capacity increasing to 30% per year after 2020, adjusting to 14%

TABLE 5.9 | BIOMASS COST ASSUMPTIONS

	UNIT	2012	2020	2030	2040	2050
BIOMASS POWER PLANT INVESTMENT COSTS	\$/kWp	2,380	2,290	2,210	2,130	2,070
O & M COSTS	\$(/kW · a)	83	80	77	74	72
BIOMASS CHP PLANT INVESTMENT COSTS	\$/kWp	4,040	3,890	3,770	3,590	3,380
O & M COSTS	\$(/kW · a)	152	146	142	135	127

beyond 2030, the result would be a cost reduction potential of more than 60% by 2050:

- for conventional geothermal power, from 15 cents/kWh to about 9 cents/kWh;
- for EGS, despite the presently high figures (about 20 cents/kWh), electricity production costs - depending on the payments for heat supply - are expected to come down to around 8 cents/kWh in the long term.

Because of its non-fluctuating supply and flexibility of operation, geothermal energy could be a key element in a future supply structure based on renewable sources. Up to now we have only used a marginal part of the potential. Shallow geothermal drilling, for example, can deliver of heating at any time anywhere, and can be used for thermal energy storage.

### Ocean energy

Ocean energy, particularly offshore wave energy, is a significant resource, and has the potential to satisfy an important percentage of electricity supply worldwide. Globally, the potential of ocean energy has been estimated at around 90,000 TWh/year. The most significant advantages are the vast availability and high predictability of the resource and a technology with very low visual impact and no CO<sub>2</sub> emissions. Many different concepts and devices have been developed, including taking energy from the tides, waves, currents and both thermal and saline gradient resources. Many of these are in an advanced phase of research & development, large scale prototypes have been deployed in real sea conditions and some have reached pre-market deployment. There are a few grid connected, fully operational commercial wave and tidal generating plants.

The cost of energy from initial tidal and wave energy farms has been estimated to be in the range of 20-80 €cents/kWh,<sup>25</sup>

TABLE 5.10 | GEOTHERMAL POWER COST ASSUMPTIONS

	UNIT	2012	2020	2030	2040	2050
GEOTHERMAL PLANT INVESTMENT COSTS	\$/kWp	13,560	9,330	6,380	5,310	4,560
O & M COSTS	\$(/kW · a)	273	188	129	107	92

TABLE 5.11 | OCEAN ENERGY COST ASSUMPTIONS

	UNIT	2012	2020	2030	2040	2050
OCEAN ENERGY INVESTMENT COSTS	\$/kWp	7,090	6,150	4,480	2,870	1,690
O & M COSTS	\$(/kW · a)	204	177	129	83	49

and for initial tidal stream farms in the range of 11-22 €cents/kWh with significant learning prospects. Key areas for development will include concept design, optimisation of the device configuration, reduction of capital costs by exploring the use of alternative structural materials, economies of scale and learning from operation. According to the latest research findings, the learning factor is estimated to be 10-15% for offshore wave and 5-10% for tidal stream. In the long term, ocean energy has the potential to become one of the most competitive and cost effective forms of generation. In the next few years a dynamic market penetration is expected, following a similar curve to wind energy.

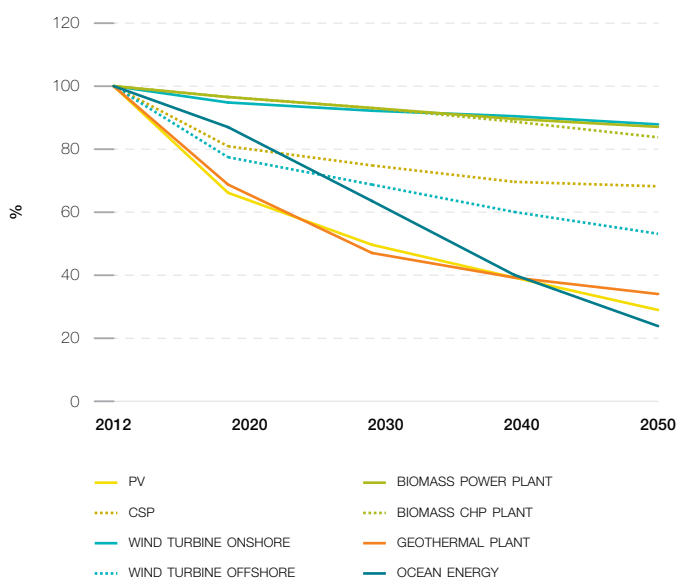
Because of the early development stage any future cost estimates for ocean energy systems are uncertain.

### Hydropower

Hydropower is a mature technology with a significant part of its global resource already exploited. There is still, however, some potential left both for new schemes (especially small scale run-of-river projects with little or no reservoir impoundment) and for repowering of existing sites. There is likely to be some more potential for hydropower with the increasing need for flood control and the maintenance of water supply during dry periods. Sustainable hydropower makes an effort to integrate plants with river ecosystems while reconciling ecology with economically attractive power generation.

**FIGURE 5.1 | FUTURE DEVELOPMENT OF INVESTMENT COSTS FOR RENEWABLE ENERGY TECHNOLOGIES**

NORMALIZED TO 2012 COST LEVELS



note \$ ct/kWh, converted using an exchange rate €2012 to \$2012 of 1,236; biomass CHP costs without heat credits.

### REFERENCES

25 G.J. DALTON, T. LEWIS (2011): PERFORMANCE AND ECONOMIC FEASIBILITY ANALYSIS OF 5 WAVE ENERGY DEVICES OFF THE WEST COAST OF IRELAND; EWTEC 2011.

**TABLE 5.12 | HYDRO POWER COST ASSUMPTIONS**

	UNIT	2012	2020	2030	2040	2050
<b>HYDRO POWER PLANT</b>						
INVESTMENT COSTS	\$/kWp	3,160	3,270	3,400	3,520	3,620
O & M COSTS	\$(kW · a)	74	76	79	82	84

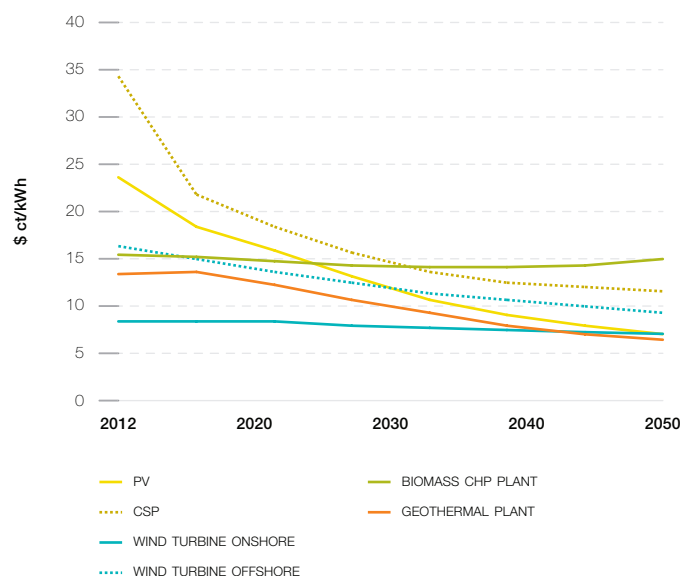
### Summary of renewable energy cost development

Figure 5.1 summarises the cost trends for renewable power technologies derived from the assumptions discussed above. It is important to note that the expected cost reduction is not a function of time, but of cumulative capacity (production of units), so dynamic market development is required.

Reduced investment costs for renewable energy technologies lead directly to lower heat and electricity generation costs, as shown in Figure 5.2. In the long term, full costs are expected to converge at around 5 to 9 €cents/kWh (6-12 \$cents/kWh), except for biomass with about 12 €cents/kWh (15 \$cents/kWh, calculated without heat credits for CHP). These estimates depend on site-specific conditions such as the local wind regime or solar irradiation, the availability of biomass at reasonable prices or the credit granted for heat supply in the case of combined heat and power generation.

**FIGURE 5.2 | EXPECTED DEVELOPMENT OF ELECTRICITY GENERATION COSTS FROM RENEWABLE POWER GENERATION IN THE ENERGY [R]EVOLUTION SCENARIOS**

DEPENDING ON THE ASSUMED DEVELOPMENT OF FULL LOAD HOURS PER YEAR, EXAMPLE FOR OECD EUROPE



#### 5.4.6 COST PROJECTIONS FOR RENEWABLE HEATING TECHNOLOGIES

Renewable heating has the longest tradition of all renewable technologies. For the previous Energy [R]evolution report 2012 EREC and DLR carried out a joint survey on costs of renewable heating technologies in Europe. The report analysed installation costs of renewable heating technologies, ranging from direct solar collector systems to geothermal and ambient heat applications and biomass technologies. Some technologies are already mature and compete on the market – especially simple heating systems in the domestic sector. However, more sophisticated technologies, which can provide higher shares of heat demand from renewable sources, are still under development and rather expensive. Market barriers slow down the further implementation and cost reduction of renewable heating systems, especially for heating networks. Nevertheless, significant learning rates can be expected if renewable heating is increasingly implemented as projected in the Energy [R]evolution scenario.

##### Solar thermal technologies

Solar collectors depend on direct solar irradiation, so the yield strongly depends on the location. In very sunny regions, simple thermosiphon systems can provide total hot water demand in households at around 400 €/m<sup>2</sup> installation costs. In regions with less sun, where additional space heating is needed, installation cost for pumped systems are twice as high. In these areas, economies of scales can decrease solar heating costs significantly. Large scale solar collector system are known from 250-600 €/m<sup>2</sup>, depending on the share of solar energy in the whole heating system and the level of storage required.

##### Deep geothermal applications

(Deep) geothermal heat from aquifers or reservoirs can be used directly in hydrothermal heating plants to supply heat demand close to the plant or in a district heating network for several different types of heat (see Chapter 10). Due to the high drilling costs deep geothermal energy is mostly feasibly for large applications in combination with heat networks. It is already economic feasible and in use for a long time, where aquifers can be found near the surface, e.g. in the Pacific Island or along the Pacific Ring of Fire. Also in Europe deep geothermal applications are being developed for heating purposes at investment costs from 500€/kW<sub>th</sub> (shallow) to 3000 €/kW<sub>th</sub> (deep), with the costs strongly dependent on the drilling depth.

##### Heat pumps

Heat pumps typically provide hot water or space heat for heating systems with relatively low supply temperature or can serve as a supplement to other heating technologies. They have become increasingly popular for underfloor heating in buildings. Economies of scale are less important than for deep geothermal, so there is focus on small household applications with investment costs from 500-1,600 €/kW for ground water systems and higher costs from 1,200-3,000 €/kW for ground source or aérothermal systems.

##### Biomass applications

There is broad portfolio of modern technologies for heat production from biomass, ranging from small scale single room stoves to heating or CHP-plants in MW scale. Investment costs show a similar variety: simple log wood stoves can be obtained from 100 €/kW, more sophisticated automated heating systems that cover the whole heat demand of a building are significantly more expensive. Log wood or pellet boilers range from 400-1,200 €/kW, with large applications being cheaper than small systems.

Economy of scales apply to heating plants above 500 kW, with investment cost between 400-700 €/kW. Heating plants can deliver process heat or provide whole neighbourhoods with heat. Even if heat networks demand additional investment, there is great potential to use solid biomass for heat generation in both small and large heating centres linked to local heating networks.

Heat from cogeneration (CHP) is another option with a broad range of technologies at hand. It is a very varied energy technology – applying to co-firing in large coal-fired cogeneration plants; biomass gasification combined with CHP or biogas from wet residues. But the costs for heat are often mainly dependent on the power production.

Main biomass input into renewable heating today is solid biomass – wood in various specifications from waste wood and residues to pellets from short rotation forestry. Biomass costs are as versatile: In Europe biomass costs ranged from 1-6 €/GJ for sawmill products, over 2-7 €/GJ for log wood to 6-18 €/GJ for wood pellets.<sup>26</sup>

Cost reductions expected vary strongly within each technology sector, depending on the maturity of a specific technology. E.g. small wood stoves will not see significant cost reductions, while there is still learning potential for automated pellet heating systems. Cost for simple solar collectors for swimming pools might be already optimized, whereas integration in large systems is neither technological nor economical mature. Table 5.13 shows average development pathways for a variety of heat technology options.

#### REFERENCES

<sup>26</sup> OLSON, O. ET AL. (2010): WP3-WOOD FUEL PRICE STATISTICS IN EUROPE - D.31. SOLUTIONS FOR BIOMASS FUEL MARKET BARRIERS AND RAW MATERIAL AVAILABILITY. EUBIONET3. UPPSALA, SWEDEN, SWEDISH UNIVERSITY OF AGRICULTURAL SCIENCES.



**TABLE 5.13 | OVERVIEW OF EXPECTED INVESTMENT AND OPERATION & MAINTENANCE COSTS PATHWAYS FOR HEATING TECHNOLOGIES IN EUROPE**

	UNIT	2012	2020	2030	2040	2050
GEOHERMAL DISTRICT HEATING*	\$/kW	2,650	2,520	2,250	2,000	1,760
HEAT PUMPS	\$/kW	1,990	1,930	1,810	1,710	1,600
LOW TECH SOLAR COLLECTORS	\$/kW	140	140	140	140	140
SMALL SOLAR COLLECTOR SYSTEMS	\$/kW	1,170	1,120	1,010	890	750
LARGE SOLAR COLLECTOR SYSTEMS	\$/kW	950	910	810	720	610
SOLAR DISTRICT HEATING*	\$/kW	1,080	1,030	920	820	690
LOW TECH BIOMASS STOVES	\$/kW	130	130	130	130	130
BIOMASS HEATING SYSTEMS	\$/kW	930	900	850	800	750
BIOMASS DISTRICT HEATING*	\$/kW	660	640	600	570	530

\* Without network

#### 5.4.7 ASSUMPTIONS FOR HYDROGEN AND SYNFUEL PRODUCTION FROM RENEWABLE ELECTRICITY

In the Energy [R]evolution scenarios hydrogen is introduced as a substitute for natural gas with significant shares after 2030. Hydrogen is assumed to be produced via electrolysis, resulting in an additional electricity demand fully supplied by extra renewable power production capacities mainly from wind, PV and CSP.

Renewable hydrogen is essential in the Energy [R]evolution scenarios for a variety of sectors:

In the power sector hydrogen replaces natural gas in gas power plants with increasing shares after 2030, totally replacing natural gas in the Advanced Energy [R]evolution scenario by 2050. It thus serves as backup for fluctuating electricity production from wind and PV, securing electricity supply at all times.

For the industry sector, hydrogen serves as an additional renewable fuel option for high-temperature applications, supplementing biomass in industrial processes, whenever direct use of renewable electricity is not applicable. In the Advanced Energy [R]evolution scenario, hydrogen totally replaces the remaining gas demand by 2050.

The transport sector also increasingly relies on hydrogen as a renewable fuel, where battery supported electric vehicles reach their limitations and where limited biomass potentials restrict the extension of biofuel use. However, future application of hydrogen might not suffice to replace all fossil fuel demand, especially in aviation, heavy duty vehicles and navigation. Thus the new Energy [R]evolution study introduces synthetic hydrocarbons from renewable hydrogen, electricity and biogenic/atmospheric CO<sub>2</sub>. These synfuels are introduced after 2030 in the Advanced Energy [R]evolution scenario. They provide for the remaining fossil fuel demand that cannot be supplied by biofuels due to limited potentials.

**TABLE 5.14 | ASSUMPTIONS FOR HYDROGEN AND SYNFUEL PRODUCTION<sup>27</sup>**

	UNIT	2012	2020	2030	2040	2050
<b>HYDROGEN PRODUCTION</b>						
EFFICIENCY	%	65	68	71	73	75
<b>INVESTMENT COSTS</b>						
	\$/2012/kW	1,530	1,339	956	720	630
<b>SYNTHETIC HYDROCARBON PRODUCTION</b>						
EFFICIENCY	%	36	37	40	41	42

#### REFERENCES

<sup>27</sup> OWN ASSUMPTIONS, BASED ON DATA FROM THE HELMHOLTZ ALLIANCE PROJECT "SYNTHETIC LIQUID HYDROCARBONS" (SYNKWS), DLR, 2015.

### 5.4.8 ASSUMED GROWTH RATES IN SCENARIO DEVELOPMENT

Table 5.15 shows annual market volumes and growth rates resulting from the scenarios which are used to cross-check dynamics of deployment pathways.

**TABLE 5.15 | ASSUMED AVERAGE GROWTH RATES AND ANNUAL MARKET VOLUMES BY RENEWABLE TECHNOLOGY**

	GENERATION [TWh/A]			INSTALLED CAPACITY [GW]			ANNUAL MARKET VOLUME [GW/A]			ANNUAL GROWTH RATE BASED ON GENERATION [%/A]			ELECTRICITY SHARE		
	REF	E[R]	ADV E[R]	REF	E[R]	ADV E[R]	REF	E[R]	ADV E[R]	REF	E[R]	ADV E[R]	REF	E[R]	ADV E[R]
2012	22,604	22,604	22,604	5,680	5,680	5,680									
2020	28,492	27,292	27,586	7,343	7,492	7,645									
2030	36,256	33,631	36,867	9,130	11,521	13,146									
2050	50,110	49,852	67,535	12,033	19,469	25,835									
<b>PV</b>															
2012	97	97	97	97	97	97	39	39	39						
2020	408	942	1,090	332	732	844	29	79	93	23%	38%	41%	1.4%	3.5%	4.0%
2030	630	3,844	5,067	494	2,839	3,725	16	211	288	5%	17%	19%	1.7%	11.4%	13.7%
2050	1,096	9,914	13,613	803	6,745	9,295	15	195	279	3%	5%	5%	2.2%	19.9%	20.2%
<b>CSP</b>															
2012	5	5	5	3	3	3	1	1	1						
2020	34	97	131	11	31	42	1	4	5	33%	54%	61%	0.1%	0.4%	0.5%
2030	85	1,601	2,552	26	405	635	1	37	59	11%	37%	39%	0.2%	4.8%	6.9%
2050	303	8,138	14,035	74	1,473	2,555	2	53	96	7%	9%	9%	0.6%	16.3%	20.8%
<b>WIND ON+OFFSHORE</b>															
2012	521	521	521	277	277	277	52	52	52						
2020	1,254	1,932	2,158	554	820	904	35	68	78	13%	21%	23%	4.4%	7.1%	7.8%
2030	1,962	6,278	7,737	807	2,510	3,064	25	169	216	5%	14%	15%	5.4%	18.7%	21.0%
2050	3,202	14,938	21,673	1,217	5,575	8,040	21	153	249	3%	5%	6%	6.4%	30.0%	32.1%
<b>GEO THERMAL FOR POWER GENERATION</b>															
2012	70	70	70	11	11	11	1	1	1						
2020	113	190	210	17	28	31	1	2	3	7%	15%	17%	0.4%	0.7%	0.8%
2030	188	916	1,149	28	137	171	1	11	14	6%	19%	21%	0.5%	2.7%	3.1%
2050	425	3,286	4,547	62	485	708	2	17	27	4%	7%	8%	0.8%	6.6%	6.7%
<b>BIOENERGY FOR POWER GENERATION</b>															
2012	379	379	379	87	87	87	8	8	8						
2020	740	937	979	150	194	200	8	13	14	10%	14%	15%	2.6%	3.4%	3.5%
2030	1,039	1,915	1,993	199	392	405	5	20	21	4%	8%	8%	2.9%	5.7%	5.4%
2050	1,577	3,039	3,193	293	746	742	5	18	17	2%	2%	3%	3.1%	6.1%	4.7%
<b>OCEAN</b>															
2012	1	1	1	0	0	0	0	0	0						
2020	3	31	32	1	11	11	0	1	1	29%	80%	81%	0.0%	0.1%	0.1%
2030	13	251	363	4	95	131	0	8	12	15%	26%	31%	0.0%	0.7%	1.0%
2050	76	1,482	2,010	28	552	738	1	23	30	11%	10%	9%	0.2%	3.0%	3.0%
<b>HYDRO</b>															
2012	3,672	3,672	3,672	1,099	1,099	1,099	37	37	37						
2020	4,458	4,349	4,349	1,331	1,316	1,316	29	27	27	3%	2%	2%	15.6%	15.9%	15.8%
2030	5,207	4,613	4,621	1,544	1,397	1,402	21	8	9	2%	1%	1%	14.4%	13.7%	12.5%
2050	6,431	4,937	4,966	1,878	1,503	1,536	17	5	7	1%	0%	0%	12.8%	9.9%	7.4%

### 5.4.9 ASSUMPTIONS FOR FOSSIL FUEL PHASE OUT

More than 80% of the current energy supply is based on fossil fuels. Oil dominates the entire transport sector; oil and gas make up the heating sector and coal is the most-used fuel for power. Each sector has different renewable energy and energy efficiency technologies combinations which depend on the locally available resources, infrastructure and to some extent, lifestyle.

In line with the overall targets, the Energy [R]evolution scenarios need to map out a clear pathway to phase-out oil in the short-term, coal in the mid-term and gas in the long-term. Such a pathway was described in a study from the German Institute “Ludwig Bolkow System Technik” (LBST) for the Energy [R]evolution 2012 edition. The institute did a detailed analysis of the global conventional oil resources, current infrastructure of those industries, the estimated production capacities of existing oil wells and the investment plans known by end 2011. Greenpeace asked LBST to evaluate the remaining fossil fuel resources between 2012 and 2050 with no new deep sea and arctic oil exploration, no oil shale and tar sand mining because of two reasons:

- First and foremost, to limit the carbon emission to save the climate.

- Secondly, to outline a production scenario in which all financial resources flow from 2012 onwards only in the development of new and larger markets for renewable energy technologies and energy efficiency to avoid “locking-in” new fossil fuel infrastructure.

The following graphs show how fossil fuel resources can phase out according to this analysis. This parameter, along with the climate targets, is fundamental to the Energy [R]evolution scenarios.

#### Oil – production decline assumptions

Figure 5.3 shows the remaining production capacities and the additional production capacities assuming all new projects planned for 2012 till 2020 will go ahead. Even with new projects, the amount of remaining conventional oil is very limited and therefore a transition towards a low oil demand pattern is essential.

#### Coal – production decline assumptions

While there is an urgent need for a transition away from oil and gas to avoid “locking-in” investments in new production wells, the climate is the clearly limiting factor for the coal resource, not its availability( see Figure 5.4). All existing coal mines – even without any new expansion of mines – could produce far more coal, but its burning puts the world on a catastrophic climate change pathway.

FIGURE 5.3 | GLOBAL OIL PRODUCTION 1950 – 2011 AND PROJECTIONS UNTIL 2050

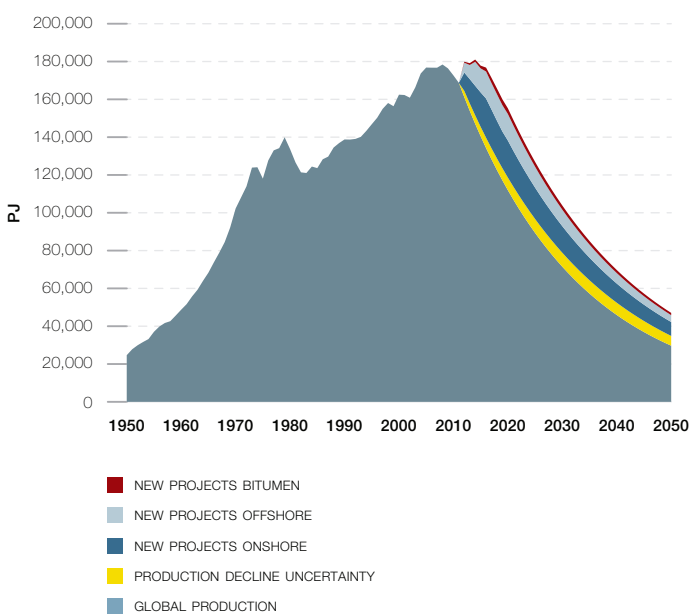
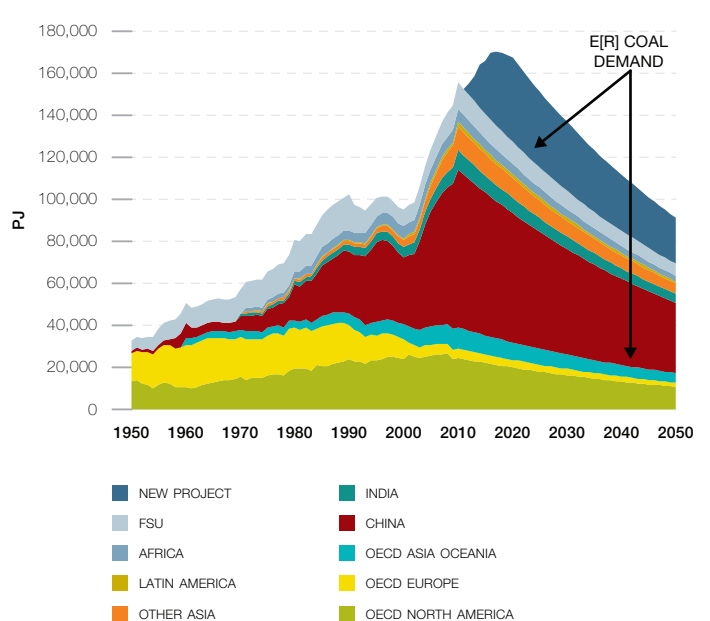


FIGURE 5.4 | COAL SCENARIO: BASE DECLINE OF 2% PER YEAR AND NEW PROJECTS FSU: FORMER SOVIET UNION



## 5.5 REVIEW: GREENPEACE SCENARIO PROJECTIONS OF THE PAST

Greenpeace has published numerous projections in cooperation with Renewable Industry Associations and scientific institutions in the past decade. This section provides an overview of the projections between 2000 and 2014 and compares them with real market developments and projections of the IEA World Energy Outlook – the basis for our reference scenario.

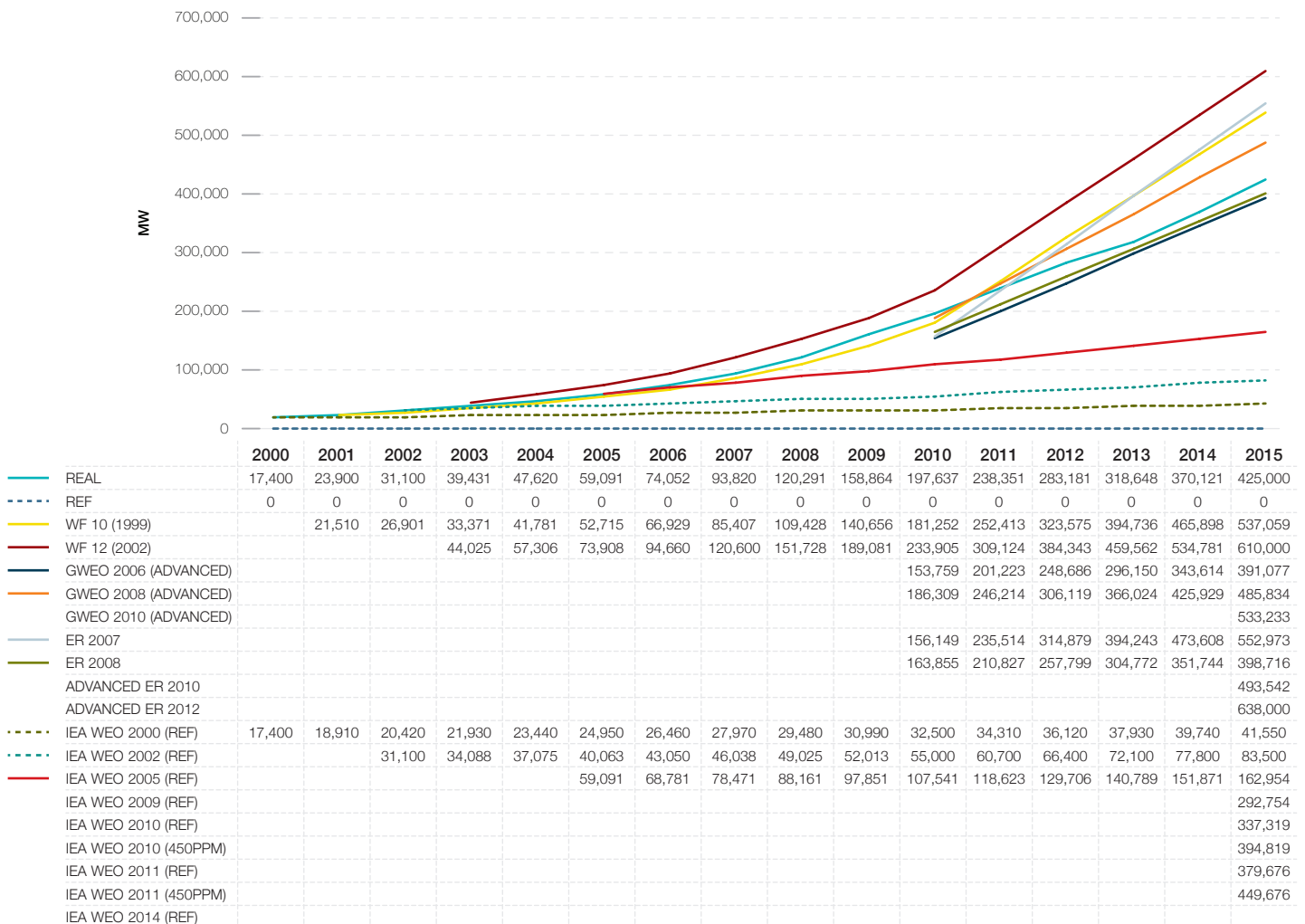
### 5.5.1 THE DEVELOPMENT OF THE GLOBAL WIND INDUSTRY

Greenpeace and the European Wind Energy Association published “Windforce 10” for the first time in 1999 – a global

market projection for wind turbines until 2030. Since then, an updated prognosis has been published every second year. Since 2006 the report has been renamed into “Global Wind Energy Outlook” with a new partner – the Global Wind Energy Council (GWEC) – a new umbrella organisation of all regional wind industry associations. Figure 5.5 shows the projections made each year between 2000 and 2012 compared to the real market data. The graph also includes the first three Energy [R]evolution (ER) editions (published in 2007, 2008 and 2010) against the IEA’s wind projections published in World Energy Outlook (WEO) 2000, 2002, 2005, 2008 and 2010.

The projections from the “Wind force 10” and “Windforce 12” were calculated by BTM consultants, Denmark.

FIGURE 5.5 | WIND POWER – SHORT TERM PROGNOSIS VS REAL DEVELOPMENT – GLOBAL CUMULATIVE CAPACITY



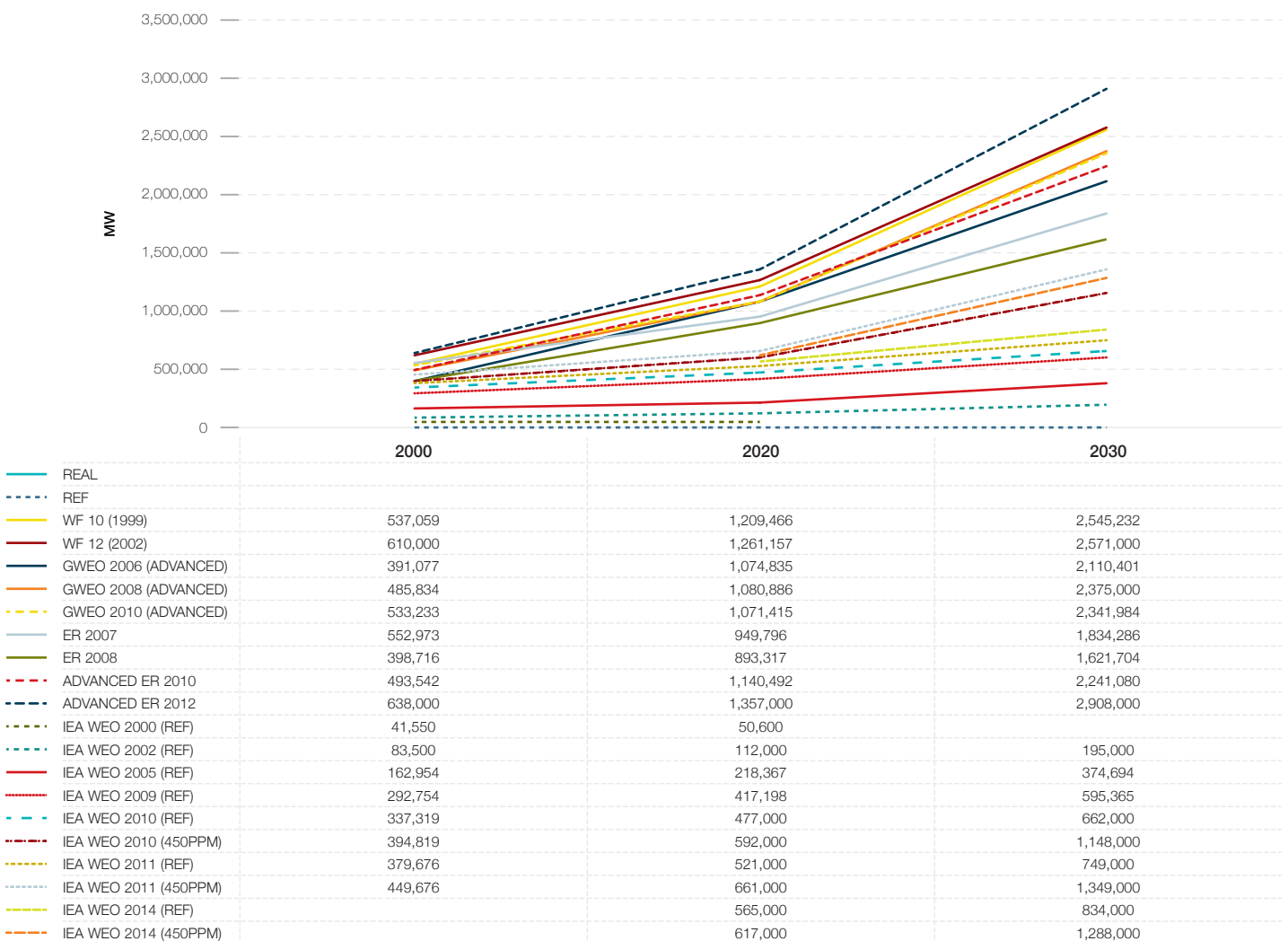
“Windforce 10” (2001 - 2011) exact projection for the global wind market published during this time, at 10% below the actual market development; also all following editions were around 10% above or below the real market. From 2006 onwards, the new “Global Wind Energy Outlook” had two different scenarios, a moderate and an advanced wind power market projection calculated by GWEC and Greenpeace International. The figures here show only the advanced projections, as the moderate were too low. However, these projections were the most criticised at the time, being called “over ambitious” or even “impossible”.

In contrast, the IEA “Current Policies” projections seriously underestimated the wind industry’s ability to increase

manufacturing capacity and reduce costs. In 2000, the IEA WEO published projections of global installed capacity for wind turbines of 32,500 MW for 2010. This capacity had been connected to the grid by early 2003, only two-and-a-half years later. In 2014, the annual global wind market was at 39,000 MW increasing the total cumulative capacity to around 370,000 MW; around ten times more than the IEA’s assumption a decade earlier.

Only time will tell if the GPI/DLR/GWEC longer-term projections for the global wind industry will remain close to the real market. However the IEA WEO projections over the past decade have been constantly increased and keep coming close to our progressive growth rates.

FIGURE 5.6 | WIND POWER – LONG TERM MARKET PROJECTIONS UNTIL 2030



**BOX 5.1 | ARTICLE FROM MEISTER CONSULTANTS GROUP**  
“RENEWABLE ENERGY REVOLUTION” PUBLISHED MARCH 16, 2015<sup>28</sup>

**The energy world is undergoing massive transformation.**

**Installations of renewable energy have skyrocketed around the world, exceeding most predictions from less than a decade ago.**

A record-breaking amount of wind and solar power was installed globally in 2014, in what the US Department of Energy has characterized as an “energy revolution.” But how strong is this momentum? How much have renewable technologies like solar PV and wind actually grown in recent years?

**Solar and wind: outpacing (most) expert projections.**

Over the past 15 years, a number of predictions – by the International Energy Agency, the US Energy Information Administration, and others – have been made about the future of renewable energy growth. Almost every one of these predictions has underestimated the scale of actual growth experienced by the wind and solar markets.

Only the most aggressive growth projections, such as Greenpeace’s Energy [R]evolution scenarios, have been close to accurate.

Greenpeace’s projections have been predicated upon drastic structural, policy, and business changes. The recent moves seen by E.ON, China, and across countless other local and global institutions suggest that these changes are already underway.

**What lies ahead?**

No one knows what the future electricity mix will look like, and that uncertainty is mirrored more broadly in projections for the energy system as a whole. Approximately 13% of global primary energy demand is derived from renewable sources, and it is almost a certainty that renewables will continue to expand. The question is: by how much? Projections and scenarios range from 15% to 82% of global primary energy demand by 2050.

To win in the future global marketplace, business leaders and policymakers will need to manage change effectively. The next phase in the renewable transformation will likely involve substantial changes to the structure of the global energy system. This means new policies, new business models, new grid management systems and the potential for massive disruption – all of which raise a number of questions:

- How can policymakers, businesses, and community leaders work together to effectively manage the transformation?
- How can leaders align stakeholder interests to implement the right policies and regulations across regions?
- What new business models need to be deployed to deliver greater levels of cost effective renewable and energy efficiency projects?
- How can investors mobilize to finance major energy infrastructure?

Strategic questions such as these are at the forefront of energy discussions around the world. At the same time, they presume that energy stakeholders will have some degree of control over the changes that are coming. As has been seen in the past, however, renewable energy market growth has consistently surprised (on the upside) the analysts, planners, and policymakers who have attempted to predict the future.

**REFERENCES**

<sup>28</sup> (MCG 2015); RENEWABLE ENERGY REVOLUTION” – PUBLISHED MARCH 16, 2015 (MCG 2015) [HTTP://WWW.MC-GROUP.COM/WP-CONTENT/UPLOADS/2015/03/MCG-RENEWABLE-ENERGY-REVOLUTION-INFOGRAPHIC.PDF](http://www.mcg-group.com/wp-content/uploads/2015/03/MCG-RENEWABLE-ENERGY-REVOLUTION-INFOGRAPHIC.PDF)

### 5.5.2 THE DEVELOPMENT OF THE GLOBAL SOLAR PHOTOVOLTAIC INDUSTRY

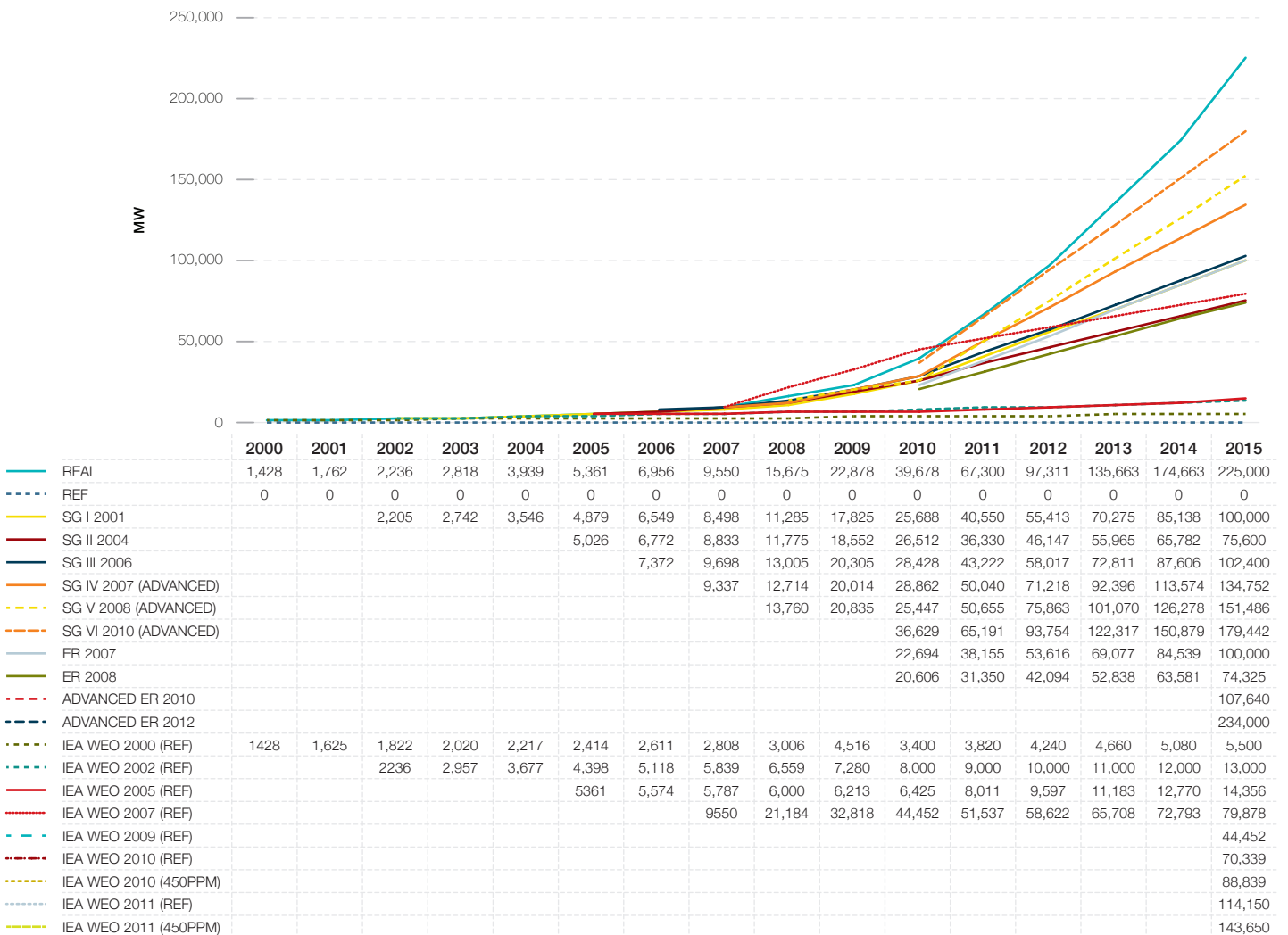
Inspired by the successful work with the European Wind Energy Association (EWEA), Greenpeace started to work with the European Photovoltaic Industry Association to publish “SolarGeneration 10” – a global market projection for solar photovoltaic technology up to 2020 for the first time in 2001. Since then, six editions have been published and EPIA and Greenpeace constantly improved the calculation methodology with experts from both organisations. Figure 5.7 shows the actual projections for each year between 2001 and 2015 compared to the real market data, against the first two Energy [R]evolution editions (published in 2007, 2008, 2010

and 2012) and the IEA’s solar projections published in World Energy Outlook (WEO) 2000, 2002, 2005, 2007, 2009, 2010 and 2011. The IEA did not make specific projections for solar photovoltaic in the first editions analysed in the research, instead used the category “Solar/Tidal/Other”.

In contrast to the wind projections, all the SolarGeneration projections have been too conservative. The total installed capacity in 2014 was 175,000 MW more than twice as high as projected in SolarGeneration 2 published a decade earlier. Even SolarGeneration 5, published in 2008, underestimated the possible market growth of photovoltaic in the advanced scenario. In contrast, the IEA WEO 2000 estimations for 2010 were reached in 2004.

5

FIGURE 5.7 | SOLAR PHOTOVOLTAIC- SHORT TERM PROGNOSIS VS REAL DEVELOPMENT - GLOBAL CUMULATIVE CAPACITY



The long-term projections for solar photovoltaic are more difficult than for wind because the costs have dropped significantly faster than projected. For most OECD countries, solar has reached grid parity with retail rates from utilities in 2014 and other solar technologies, such as concentrating solar power plants (CSP), are also headed in that direction. Therefore, future projections for solar photovoltaic do not just depend on cost improvements, but also on available storage technologies. Grid integration can actually be a bottle-neck to solar that is now expected much earlier than estimated.

### 5.6 HOW DOES THE ENERGY [R]EVOLUTION SCENARIO COMPARE TO OTHER SCENARIOS?

The International Panel on Climate Change (IPCC) published a ground-breaking new “Special Report on Renewables” (SRREN) in May 2011. This report showed the latest and most

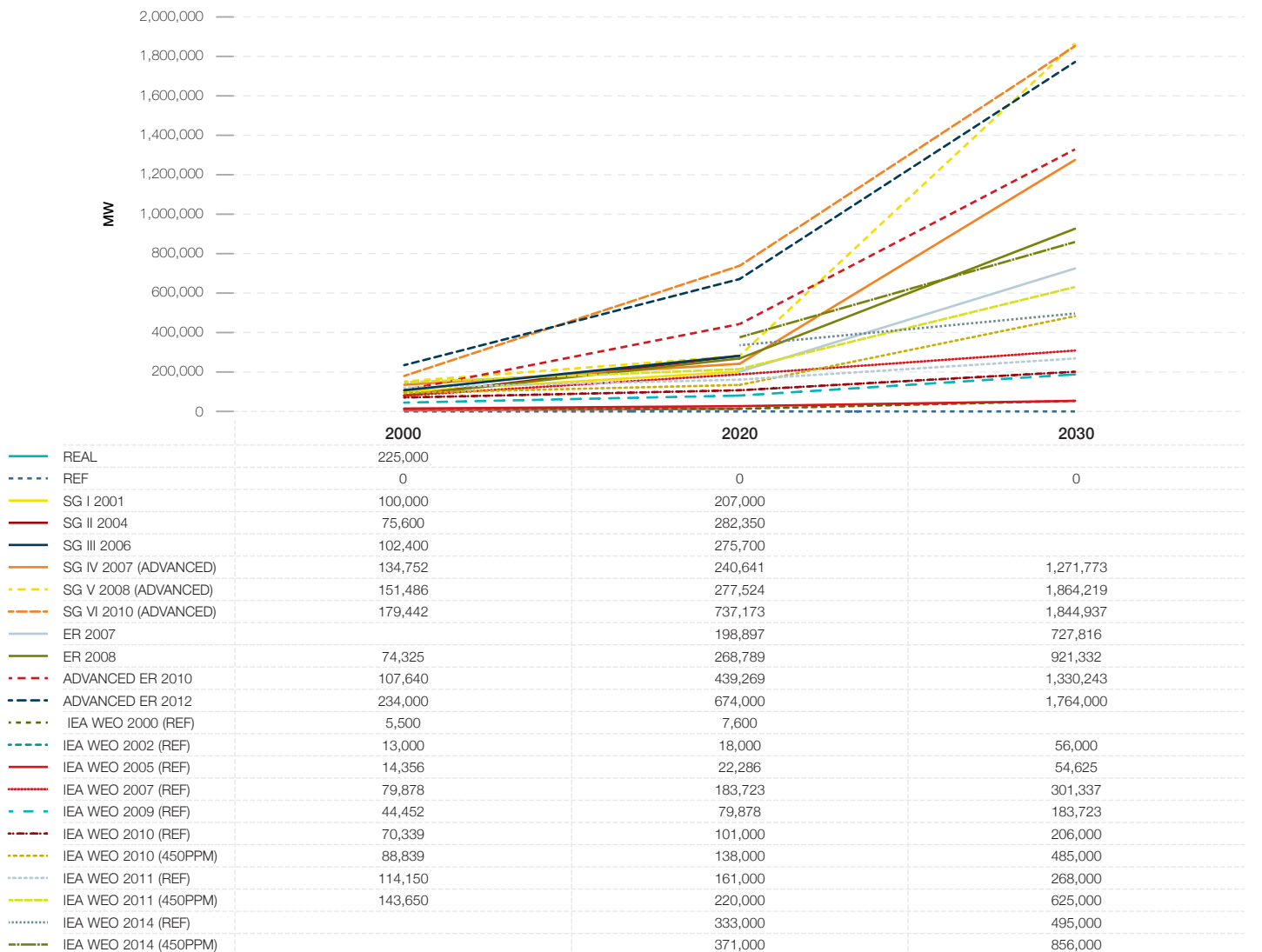
comprehensive analysis of scientific reports on all renewable energy resources and global scientifically accepted energy scenarios. The Energy [R]evolution was among three scenarios chosen as an indicative scenario for an ambitious renewable energy pathway. The following summarises the IPCC’s view.

Four future pathways, from the following models were assessed intensively:

- International Energy Agency World Energy Outlook 2009, (IEA WEO 2009)
- Greenpeace Energy [R]evolution 2010, (ER 2010)
- (ReMIND-RECIPE)
- (MiniCam EMF 22)

The World Energy Outlook of the International Energy Agency was used as an example baseline scenario (least amount of

FIGURE 5.8 | SOLAR PHOTOVOLTAIC – LONG TERM MARKET PROJECTIONS UNTIL 2030





development of renewable energy) and the other three treated as “mitigation scenarios”, to address climate change risks. The four scenarios provide substantial additional information on a number of technical details, represent a range of underlying assumptions and follow different methodologies. They provide different renewable energy deployment paths, including Greenpeace’s “optimistic application path for renewable energy assuming that the current high dynamic (increase rates) in the sector can be maintained”.

The IPCC notes that scenario results are determined partly by assumptions, but also might depend on the underlying modelling architecture and model specific restrictions, so the scenarios analysed use different modelling architectures, demand projections and technology portfolios for the supply side. The full results are provided in Table 5.16, but in summary:

- The IEA baseline has a high demand projection with low renewable energy development.
- ReMind-RECIPE, MiniCam EMF 22 scenarios portrays a high demand expectation and significant increase of renewable energy is combined with the possibility to employ CCS and nuclear.

- The ER 2010 relies on low demand (due to a significant increase of energy efficiency) combined with high renewable energy deployment, no CCS employment and a global nuclear phase-out by 2045.

Both population increase and GDP development are major driving forces on future energy demand and therefore at least indirectly determining the resulting shares of renewable energy. The IPCC analysis shows which models use assumptions based on outside inputs and what results are generated from within the models. All scenarios take a 50% increase of the global population into account on baseline 2009. Regards gross domestic product (GDP), all assume or calculate a significant increase in terms of the GDP. The IEA WEO 2009 and the ER 2010 model use forecasts of the International Monetary Fund (IMF 2009) and the Organisation of Economic Co-Operation and Development (OECD) as inputs to project GSP. The other two scenarios calculate GDP from within their model. Table 5.16 provides an overview of key parameter of the IPCC analysis and puts them in the context of scenarios from IEA and Greenpeace which have been published in the aftermath of the SRREN.

**TABLE 5.16 | OVERVIEW OF KEY PARAMETERS OF THE ILLUSTRATIVE SCENARIOS BASED ON ASSUMPTIONS THAT ARE EXOGENOUS TO THE MODELS RESPECTIVE ENDOGENOUS MODEL RESULTS**

CATEGORY	STATUS QUO	BASELINE				CATEGORY III+IV (>440 - 600PPM)		CATEGORY I+ II (< 440PPM)		CATEGORY I+ II (< 440PPM)				
		IEA ETP	IEA WEO 2009		IEA WEO 2011		ReMind		MiniCam		E[R] 2010		E[R] 2012	
SCENARIO NAME														
MODEL														
YEAR OF PUBLICATION		2015	2009		2011		20xx		20xx		2010		2012	
	UNITS		2030	2050*	2030	2050*	2030	2050	2030	2050	2030	2050	2030	2050
TECHNOLOGY PATHWAY (-) TECHNOLOGY NOT INCLUDED (+) TECHNOLOGY INCLUDED														
RENEWABLES			all**	all	all**	all	PV AND CSP NOT DIFFERENTIATED		PV AND CSP NOT DIFFERENTIATED, OCEAN ENERGY NOT INCLUDED		all	all	all	all
CCS			(+)	(+)	(+)	(+)	(+)	(+)	(+)	(+)	(-)	(-)	(-)	(-)
NUCLEAR			(+)	(+)	(+)	(+)	(+)	(+)	(+)	(+)	(+)	(-)	(+)	(-)
POPULATION	BILLION	6.67	8.31	9.15	8.31	9.15	8.32	9.19	8.07	8.82	8.31	9.15	8.31	9.15
GDP/CAPITA**	K\$ <sub>2005</sub> /CAPITA	-	17.4	24.3	-	-	12.4	18.2	9.7	13.9	17.4	24.3	-	-
ENERGY DEMAND (DIRECT EQUIVALENT)	EJ/Y	568	645	749	694	805	590	674	608	690	474	407	526	481
ENERGY INTENSITY	MJ/\$2005	-	4.5	3.4	-	-	5.7	4.0	7.8	5.6	3.3	1.8	-	-
RENEWABLE ENERGY	%	13	14	15	14	16	32	48	24	31	39	77	41	82
FOSSIL & INDUSTRIAL CO <sup>e</sup> EMISSIONS	Gt CO <sub>2</sub> /Y	32.2	38.5	44.3	39.2	45.3	26.6	15.8	29.9	12.4	18.4	3.7	20.1	3.1
CARBON INTENSITY	KG CO <sub>2</sub> /GJ	-	57.1	56.6	-	-	45.0	23.5	49.2	18.0	36.7	7.1	-	-

\* IEA (2009) does not cover the years 2031 till 2050. As the IEA's projection only covers a time horizon up to 2030 for this scenario exercise, an extrapolation of the scenario has been used that was provided by the German Aerospace Agency (DLR) by extrapolating the key macroeconomic and energy indicators of WEO 2009 forward to 2050 (Teske et al., 2010c).

\*\* The data are either input for the model or endogenous model results.

\*\*\* Solar photovoltaics, Concentrated Solar Power, solar water heating, wind (on- and offshore), Geothermal power, heating and cogeneration, bioenergy power, heating and co-generation, hydro power, ocean energy.

# SCENARIO RESULTS

GLOBAL  
OECD NORTH AMERICA  
LATIN AMERICA

OECD EUROPE  
AFRICA  
MIDDLE EAST

EASTERN EUROPE/EURASIA  
INDIA  
OTHER ASIA

CHINA  
OECD ASIA OCEANIA

6



“

100% RE:  
energy supply  
without carbon  
and nuclear  
disasters”

**IMAGE** IN JUNE 2000, SWARMS OF EARTHQUAKES AND A MASSIVE VOLCANIC ERUPTION ROCKED MIYAKEJIMA, A SMALL JAPANESE ISLAND ABOUT 180 KILOMETERS (110 MILES) SOUTH OF TOKYO. BY 2015, THE ISLAND HAD A POPULATION OF 2,775 RESIDENTS. IN MANY RESPECTS, LIFE HAS RETURNED TO NORMAL. FISHING, FARMING, AND TOURISM ARE MIYAKEJIMA'S PRIMARY INDUSTRIES. SINCE OYAMA STILL PERIODICALLY EMITS LARGE AMOUNTS OF SULFUR DIOXIDE, RESIDENTS AND TOURISTS ARE SUPPOSED TO CARRY A GAS MASK WITH THEM AT ALL TIMES. ONE THIRD OF THE ISLAND REMAINS OFF LIMITS.

© NASA/EARTH OBSERVATORY IMAGE BY JESSE ALLEN

## 6.1 GLOBAL SCENARIO RESULTS

The development of future global energy demand is determined by three key factors

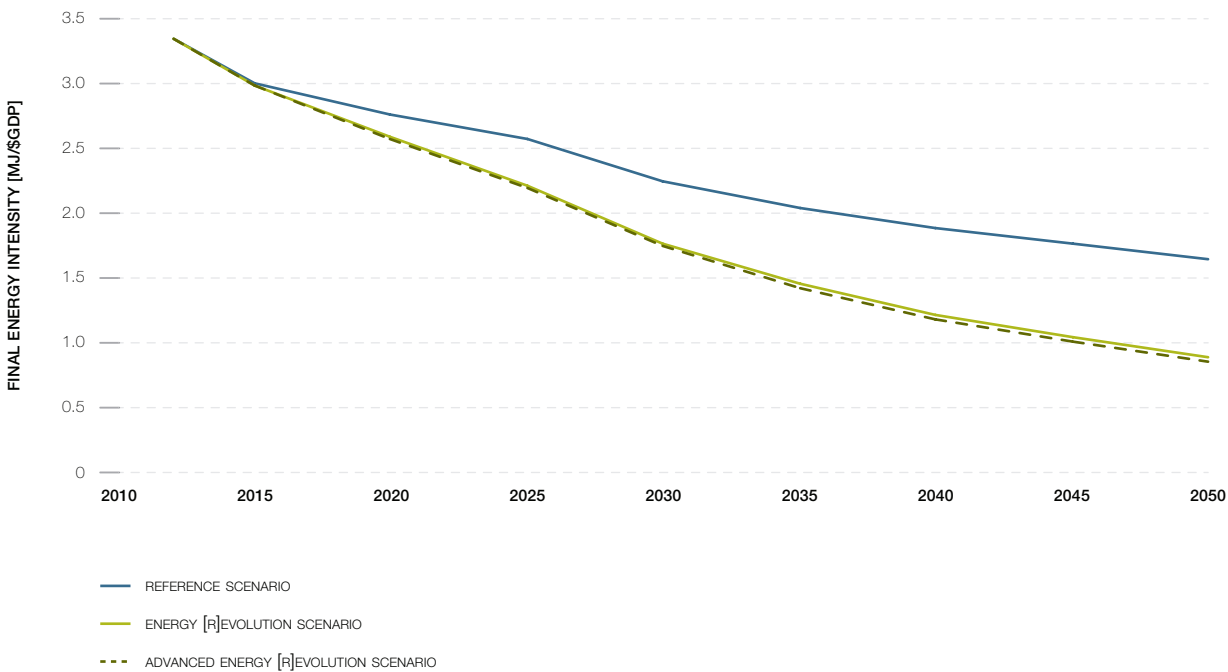
- Population development: the number of people consuming energy or using energy services.
- Economic development, for which Gross Domestic Product (GDP) is the most commonly used indicator: in general an increase in GDP triggers an increase in energy demand.
- Energy intensity: how much energy is required to produce a unit of GDP.

The Reference scenario and the Energy [R]evolution scenarios are based on the same projections of population and economic development. The future development of energy intensity, however, differs between the reference and the alternative cases, taking into account the measures to increase energy efficiency under both Energy [R]evolution scenarios.

### 6.1.1 PROJECTION OF ENERGY INTENSITY

An increase in economic activity and a growing population does not necessarily have to result in an equivalent increase in energy demand. There is still a large potential for exploiting energy efficiency measures. Under the Reference scenario we assume that energy intensity will be reduced by 1.85% on average per year, leading to a reduction in final energy demand per unit of GDP of about 51% between 2012 and 2050. Under the basic Energy [R]evolution scenario it is assumed that energy intensity decreases by 3.45% while the Advanced Energy [R]evolution achieves minus 3.55% per year due to active policy and technical support for energy efficiency measures and will lead to an even higher reduction in energy intensity of almost 75% until 2050.

FIGURE 6.1.1 | GLOBAL: FINAL ENERGY INTENSITY UNDER THE REFERENCE AND BOTH ENERGY [R]EVOLUTION SCENARIOS



6

## 6.1 WORLD

### 6.1.2 FINAL ENERGY DEMAND BY SECTOR

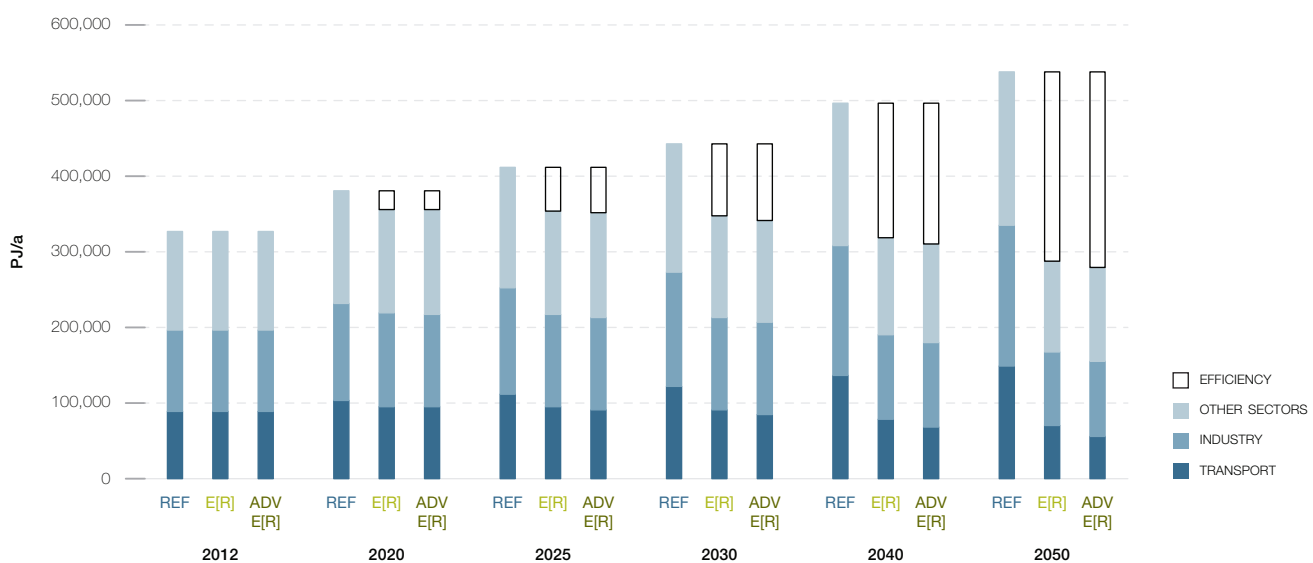
Combining the projections on population development, GDP growth and energy intensity results in future development pathways for World's final energy demand. These are shown in Figure 6. for the Reference and Energy [R]evolution scenarios. Under the Reference scenario, total final energy demand increases by 65% from the current 326,900 PJ/a to around 539,000 PJ/a in 2050. In the basic Energy [R]evolution scenario, final energy demand decreases by 12% compared to current consumption and is expected to reach 289,000 PJ/a by 2050. The Advanced scenario results in some additional reductions due to a higher share of electric cars.

Under both Energy [R]evolution scenarios, due to economic growth, increasing living standards and electrification of the transport sector, overall electricity demand is expected to increase despite efficiency gains in all sectors (see Figure 6.1.3). Total electricity demand will rise from about 18,860 TWh/a to 37,000 TWh/a by 2050 in the basic Energy [R]evolution scenario. Compared to the Reference scenario, efficiency measures in the industry, residential and service sectors avoid the generation of about 16,700 TWh/a.

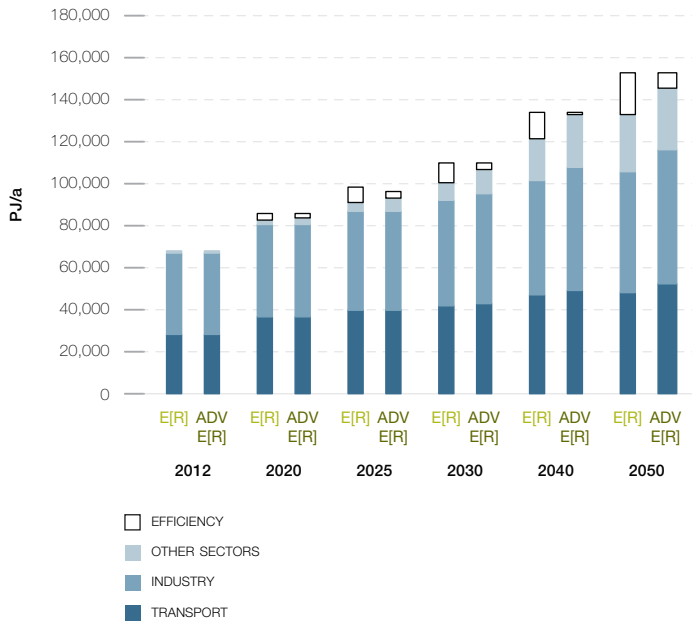
This reduction can be achieved in particular by introducing highly efficient electronic devices using the best available technology in all demand sectors. The transformation to a carbon free energy system in the Advanced scenario will further increase the electricity demand in 2050 up to more than 40,000 TWh/a. Electricity will become the major renewable 'primary' energy, not only for direct use for various purposes but also for the generation of synthetic fuels for fossil fuels substitution. Around 8,100 TWh are used in 2050 for electric vehicles and rail transport in the Advanced scenario, around 5,100 TWh for hydrogen and 3,600 TWh for synthetic liquid fuel generation for the transport sector (excluding bunkers).

Efficiency gains in the heating sector are even larger than in the electricity sector. Under the Energy [R]evolution scenarios, consumption equivalent to about 76,000 PJ/a is avoided through efficiency gains by 2050 compared to the Reference scenario. As a result of energy-related renovation of the existing stock of residential buildings, the introduction of low energy standards and 'passive climatisation' for new buildings, as well as highly efficient air conditioning systems, enjoyment of the same comfort and energy services will be accompanied with much lower future energy demand.

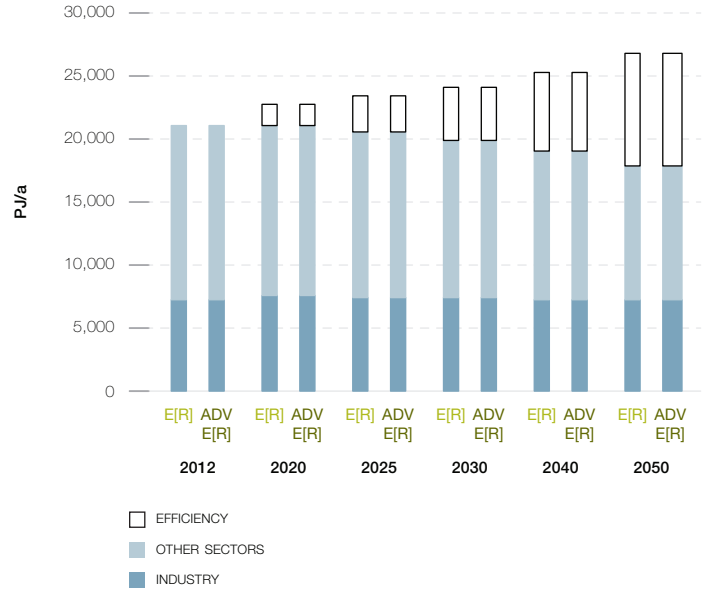
**FIGURE 6.1.2 | GLOBAL: PROJECTION OF TOTAL FINAL ENERGY DEMAND BY SECTOR – REFERENCE, ENERGY [R]EVOLUTION, ADVANCED ENERGY [R]EVOLUTION SCENARIOS** WITHOUT NON-ENERGY USE AND HEAT FROM CHP AUTOPRODUCERS



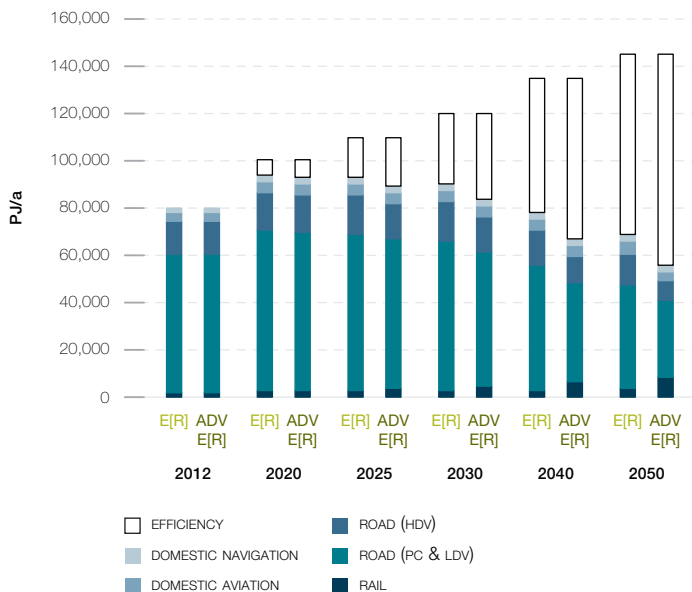
**FIGURE 6.1.3 | GLOBAL: DEVELOPMENT OF ELECTRICITY DEMAND BY SECTOR IN THE ENERGY [R]EVOLUTION SCENARIOS**



**FIGURE 6.1.5 | GLOBAL: DEVELOPMENT OF FINAL ENERGY DEMAND FOR HEAT BY SECTOR IN THE ENERGY [R]EVOLUTION SCENARIOS**



**FIGURE 6.1.4 | GLOBAL: DEVELOPMENT OF THE FINAL ENERGY DEMAND FOR TRANSPORT BY SECTOR IN THE ENERGY [R]EVOLUTION SCENARIOS**



### 6.1.2 ELECTRICITY GENERATION

The development of the electricity supply sector is characterised by a dynamically growing renewable energy market and an increasing share of renewable electricity. This trend will more than compensate for the phasing out of nuclear power production in the Energy [R]evolution scenarios, continuously reducing the number of fossil fuel-fired power plants as well. By 2050, 92% of the electricity produced worldwide will come from renewable energy sources in the basic Energy [R]evolution scenario. ‘New’ renewables – mainly wind, PV, CSP and geothermal energy – will contribute 68% to the total electricity generation. Already by 2020 the share of renewable electricity production will be 31% and 58% by 2030. The installed capacity of renewables will reach about 7,770 GW in 2030 and more than 17,000 GW by 2050.

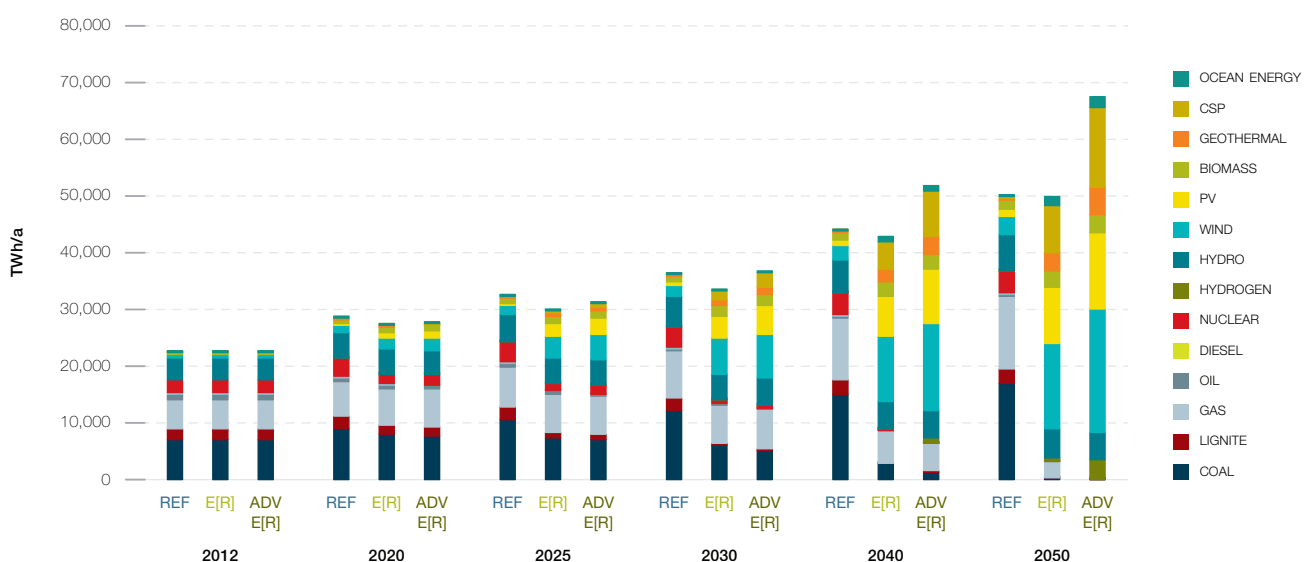
A 100% electricity supply from renewable energy resources in the Advanced scenario leads to around 23,600 GW installed generation capacity in 2050.

Table 6.1.1 shows the comparative evolution of the different renewable technologies worldwide over time. Up to 2020 wind and PV will become the main contributors to the growing market share. After 2020, the continuing growth of wind and PV will be complemented by electricity from solar thermal, geothermal and ocean energy. The Energy [R]evolution scenarios will lead to a high share of fluctuating power generation sources (PV, wind and ocean) of already 31% to 36% by 2030 and 53% to 55% by 2050. Therefore, smart grids, demand side management (DSM), energy storage capacities and other options need to be expanded in order to increase the flexibility of the power system for grid integration, load balancing and a secure supply of electricity.

**TABLE 6.1.1 | GLOBAL: PROJECTION OF RENEWABLE ELECTRICITY GENERATION CAPACITY UNDER THE REFERENCE AND THE ENERGY [R]EVOLUTION SCENARIOS**

		2012	2020	2030	2040	2050
HYDRO	REF	1,099	1,331	1,544	1,715	1,878
	E[R]	1,099	1,316	1,397	1,445	1,503
	ADV	1,099	1,316	1,402	1,457	1,536
BIOMASS	REF	87	150	199	243	293
	E[R]	87	194	392	558	746
	ADV	87	200	405	579	742
WIND	REF	277	554	807	998	1,217
	E[R]	277	820	2,510	4,316	5,575
	ADV	277	904	3,064	5,892	8,040
GEOTHERMAL	REF	11	17	28	42	62
	E[R]	11	28	137	325	485
	ADV	11	31	171	452	708
PV	REF	97	332	494	635	803
	E[R]	97	732	2,839	4,988	6,745
	ADV	97	844	3,725	6,678	9,295
CSP	REF	3	11	26	49	74
	E[R]	3	31	405	984	1,473
	ADV	3	42	635	1,616	2,555
OCEAN	REF	0	1	4	15	28
	E[R]	0	11	95	318	552
	ADV	0	11	131	432	738
TOTAL	REF	1,575	2,396	3,101	3,696	4,355
	E[R]	1,575	3,132	7,774	12,934	17,079
	ADV	1,575	3,348	9,532	17,105	23,614

**FIGURE 6.1.6 | GLOBAL: DEVELOPMENT OF ELECTRICITY GENERATION STRUCTURE – REFERENCE, ENERGY [R]EVOLUTION, ADVANCED ENERGY [R]EVOLUTION SCENARIOS**



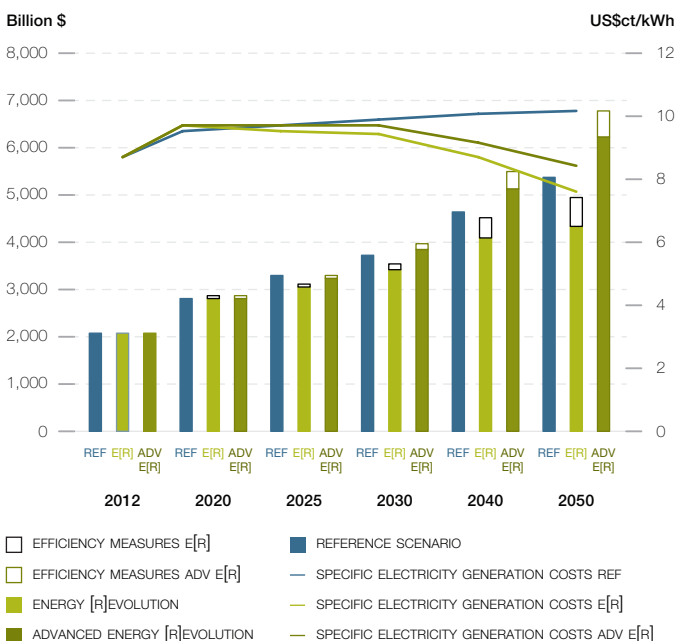
### 6.1.3 FUTURE COSTS OF ELECTRICITY GENERATION

Figure 6.1.7 shows that the introduction of renewable technologies under both Energy [R]evolution scenarios increases the future costs of electricity generation compared to the Reference scenario until 2030. This difference in full cost of generation will be less than 0.2 US\$ct/kWh in both Energy [R]evolution scenarios, without taking into account integration costs for storage or other load-balancing measures. Because of increasing prices for conventional fuels, electricity generation costs will become economically favourable starting in 2030 under the Energy [R]evolution scenarios. By 2050, the cost will be 2.5/1.7 US\$ct/kWh, respectively, below those in the Reference case.

Under the Reference scenario, on the other hand, growth in demand and increasing fossil fuel prices result in total electricity supply costs rising from today's US\$ 2,063 billion per year to more than US\$ 5,400 billion in 2050, compared to US\$ 4,300 billion in the basic and US\$ 6,200 billion in the Advanced Energy [R]evolution scenario. Figure 6.1.7 shows that both Energy [R]evolution scenarios not only comply with World's CO<sub>2</sub> reduction targets, but also help stabilise energy costs and relieve the economic pressure on society.

Increasing energy efficiency and shifting energy supply to renewables lead to long term costs for electricity supply that are more than 19% lower in the basic Energy [R]evolution scenario than in the Reference scenario. The Advanced scenario with 100% renewable power and an increase in power generation of 35% results in supply costs 16% higher than the Reference case.

**FIGURE 6.1.7 | GLOBAL: DEVELOPMENT OF TOTAL ELECTRICITY SUPPLY COSTS & OF SPECIFIC ELECTRICITY GENERATION COSTS IN THE SCENARIOS**



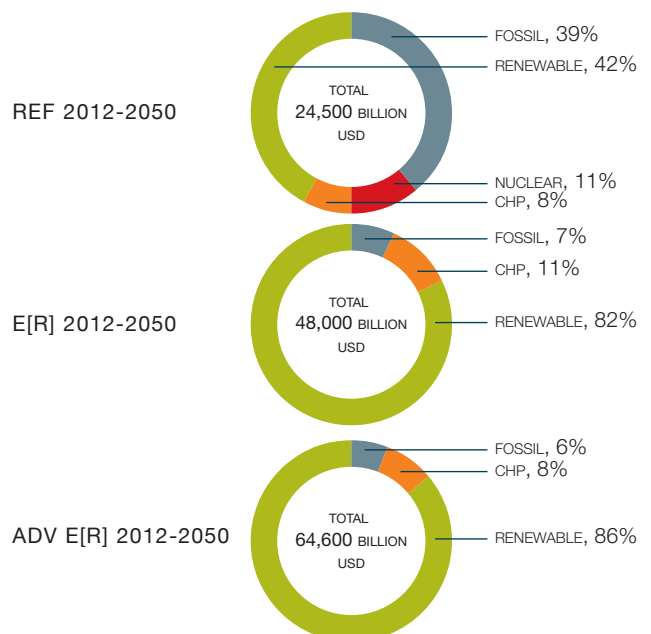
### 6.1.4 FUTURE INVESTMENTS IN THE POWER SECTOR

Around US\$ 48,000 billion is required in investment for the Energy [R]evolution scenario to become reality (including investments for replacement after the economic lifetime of the plants) - approximately US\$ 1,233 billion per year, around US\$ 23,500 billion more than in the Reference scenario (US\$ 24,500 billion). Investments for the Advanced scenario add up to US\$ 64,600 billion until 2050, on average US\$ 1,656 billion per year, including high investments in additional power plants for the production of synthetic fuels. Under the Reference scenario, the levels of investment in conventional power plants add up to almost 50% while approximately 50% would be invested in renewable energies and cogeneration until 2050.

Under the Energy [R]evolution scenarios, however, World would shift almost 93%/94% of the entire investment towards renewables and cogeneration, respectively. By 2030, the fossil fuel share of power sector investment would be focused mainly on gas power plants.

Because renewable energy has no fuel costs, the fuel cost savings in the basic Energy [R]evolution scenario reach a total of more than US\$ 39,000 billion up to 2050, around US\$ 1,000 billion per year. The total fuel cost savings therefore would cover 170% of the total additional investments compared to the Reference scenario. Fuel cost savings in the Advanced scenario are even higher and add up to US\$ 42,000 billion, or US\$ 1,080 billion per year. Renewable energy sources would then go on to produce electricity without any further fuel costs beyond 2050, while costs for coal and gas will continue to be a burden on national economies.

**FIGURE 6.1.8 | GLOBAL: INVESTMENT SHARES - REFERENCE VERSUS ENERGY [R]EVOLUTION SCENARIOS**



### 6.1.5 ENERGY SUPPLY FOR HEATING

Today, renewables meet around 21% of World's energy demand for heating, the main contribution coming from the use of biomass. Dedicated support instruments are required to ensure a dynamic development in particular for renewable technologies for buildings and renewable process heat production. In the basic Energy [R]evolution scenario, renewables already provide 42% of World's total heat demand in 2030 and 86% in 2050.

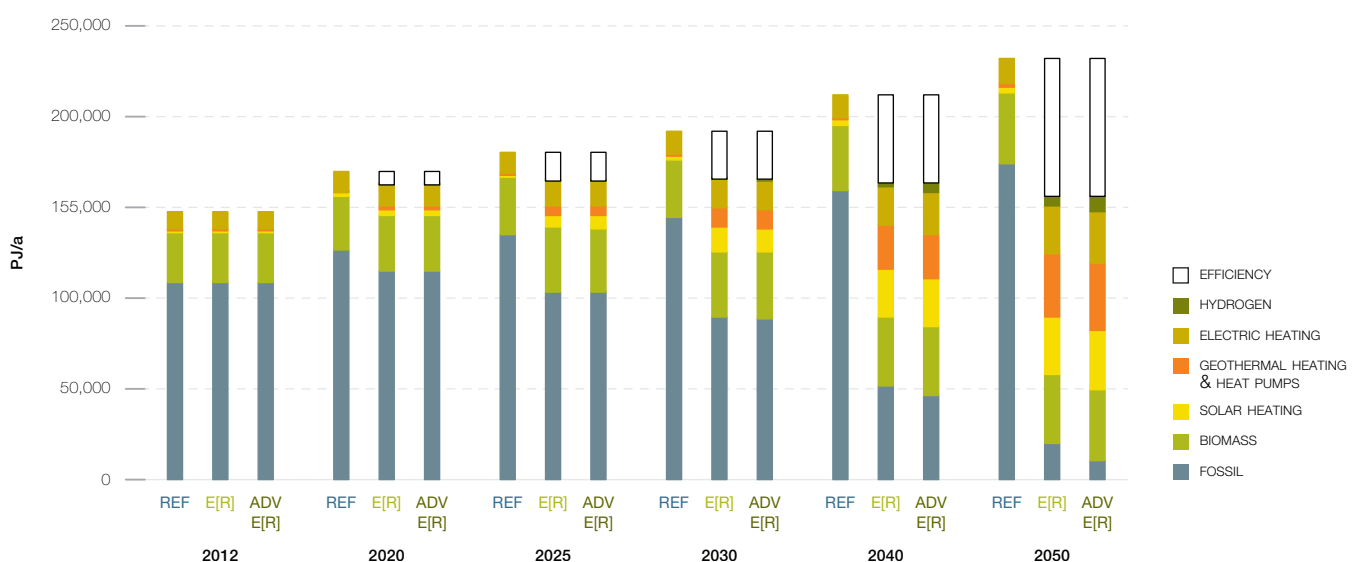
- Energy efficiency measures help to reduce the currently growing energy demand for heating by 33% in 2050 (relative to the Reference scenario), in spite of improving living standards and economic growth.
- In the industry sector solar collectors, geothermal energy (incl. heat pumps) as well as electricity and hydrogen from renewable sources are increasingly substituting for fossil fuel-fired systems.
- A shift from coal and oil to natural gas in the remaining conventional applications leads to a further reduction of CO<sub>2</sub> emissions.

Table 6.1.2 shows the development of different renewable technologies for heating worldwide over time. Up to 2030 biomass remains the main contributor of the growing market share. After 2030, the continuing growth of solar collectors and a growing share of geothermal and environmental heat as well as heat from renewable hydrogen will further reduce the dependence on fossil fuels. The Advanced scenario results in a complete substitution of the remaining gas consumption by hydrogen generated from renewable electricity.

**TABLE 6.1.2 | GLOBAL: PROJECTION OF RENEWABLE HEAT SUPPLY UNDER THE REFERENCE AND BOTH ENERGY [R]EVOLUTION SCENARIOS** IN PJ/a

		2012	2020	2030	2040	2050
BIOMASS	REF	27,486	31,115	32,467	35,590	38,986
	E[R]	27,486	34,907	36,619	38,504	38,562
	ADV	27,486	34,909	36,623	38,527	39,386
SOLAR HEATING	REF	804	1,746	2,107	2,845	3,841
	E[R]	804	6,982	12,984	25,704	31,378
	ADV	804	6,994	12,994	25,901	32,446
GEOHERMAL HEAT AND HEAT PUMPS	REF	484	810	929	1,277	1,720
	E[R]	484	5,197	10,417	24,612	34,765
	ADV	484	5,197	10,417	25,018	36,828
HYDROGEN	REF	0	0	0	0	0
	E[R]	0	163	366	1,862	6,021
	ADV	0	375	986	5,622	8,576
TOTAL	REF	28,773	33,672	35,503	39,711	44,547
	E[R]	28,773	47,249	60,385	90,682	110,725
	ADV	28,773	47,476	61,020	95,069	117,237

**FIGURE 6.1.9 | GLOBAL: PROJECTION OF HEAT SUPPLY BY ENERGY CARRIER – REFERENCE, ENERGY [R]EVOLUTION, ADVANCED ENERGY [R]EVOLUTION SCENARIOS**





### 6.1.6 FUTURE INVESTMENTS IN THE HEATING SECTOR

Also in the heating sector the Energy [R]evolution scenarios would require a major revision of current investment strategies in heating technologies. In particular, solar thermal, geothermal and heat pump technologies need an enormous increase in installations if these potentials are to be tapped for the heating sector. The use of biomass for heating purposes - often traditional biomass today - will be substantially reduced in the Energy [R]evolution scenarios and replaced by more efficient and sustainable renewable heating technologies.

Renewable heating technologies are extremely variable, from low tech biomass stoves and unglazed solar collectors to very sophisticated enhanced geothermal and solar systems. Thus, it can only be roughly estimated that the Energy [R]evolution scenario in total requires around US\$ 16,300 billion to be invested in renewable heating technologies up to 2050 (including investments for replacement after the economic lifetime of the plants) - approximately US\$ 420 billion per year.

**TABLE 6.1.3 | GLOBAL: INSTALLED CAPACITIES FOR RENEWABLE HEAT GENERATION UNDER THE SCENARIOS** IN

GW

		2012	2020	2030	2040	2050
BIOMASS	REF	12,255	12,662	12,636	12,287	11,821
	E[R]	12,255	12,418	11,218	9,329	7,276
	ADV	12,255	12,418	11,217	9,329	7,507
GEOTHERMAL	REF	2	3	6	8	9
	E[R]	2	52	328	852	1,178
	ADV	2	52	328	855	1,232
SOLAR HEATING	REF	235	401	604	810	1,088
	E[R]	235	749	3,418	6,640	7,931
	ADV	235	749	3,421	6,700	8,190
HEAT PUMPS	REF	84	119	160	221	299
	E[R]	84	229	958	1,998	2,758
	ADV	84	229	958	2,054	2,879
TOTAL*	REF	12,575	13,186	13,406	13,325	13,218
	E[R]	12,575	13,448	15,922	18,819	19,143
	ADV	12,575	13,448	15,924	18,938	19,807

\* Excluding direct electric heating.

The Advanced scenario assumes an even more ambitious expansion of renewable technologies resulting in an average investment of around US\$ 429 billion per year, while the main strategy in the scenario is the substitution of the remaining natural gas amounts with hydrogen or other synthetic fuels.

### 6.1.7 FUTURE EMPLOYMENT IN THE ENERGY SECTOR

The Advanced Energy [R]evolution scenario results in more energy sector jobs at every stage of the projection.

- There are 36.2 million energy sector jobs in the Advanced Energy [R]evolution in 2020, and 30.1 million in the Reference scenario.
- In 2025, there are 46.7 million jobs in the Advanced Energy [R]evolution scenario, and 29.6 million in the Reference scenario.
- In 2030, there are 48 million jobs in the Advanced Energy [R]evolution scenario and 28 million in the Reference scenario.

Figure 6.1.11 shows the change in job numbers under all scenarios for each technology between 2015 and 2030.

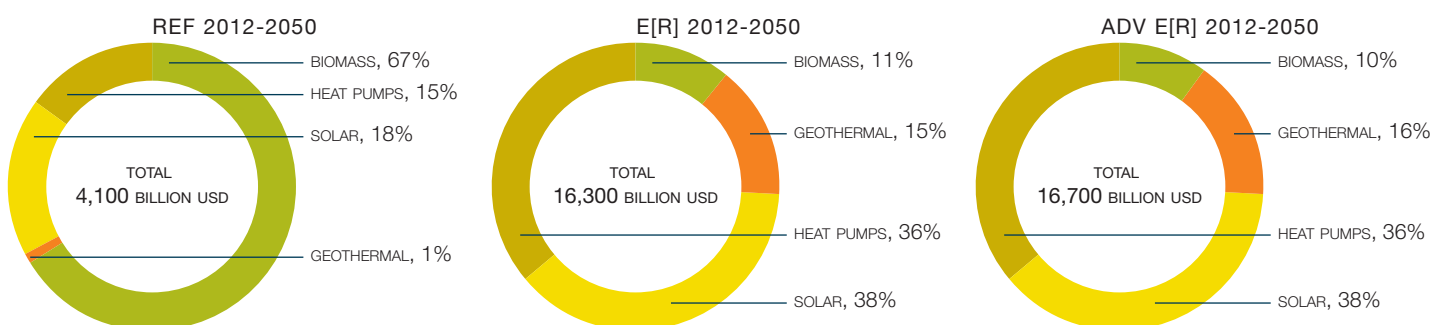
Jobs in the coal sector decline in both the Reference scenario and the Advanced Energy [R]evolution scenario, as a result of productivity improvements in the industry, coupled with a move away from coal in the Advanced Energy [R]evolution scenario.

In the Reference scenario jobs increase slightly to 2020, after which energy sector jobs decline. This is mainly driven by losses in the coal sector. At 2030, jobs are 3% (2.2 million) below 2015 levels.

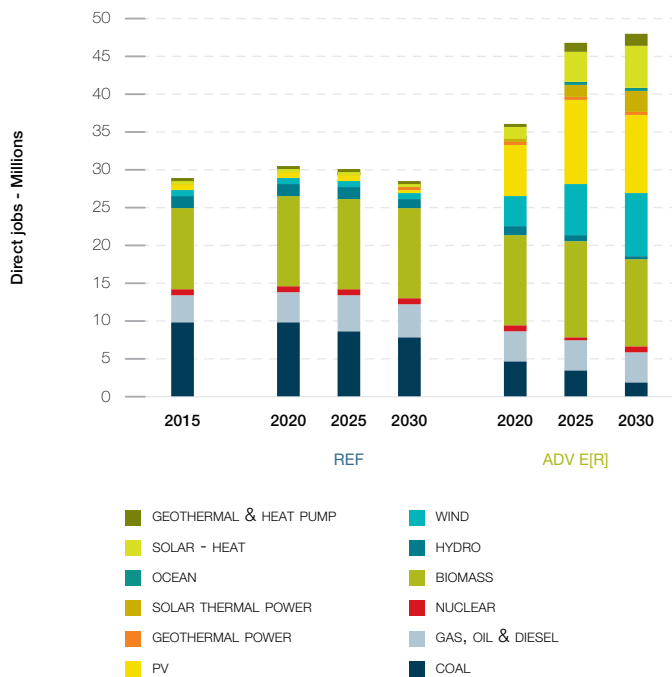
In the Advanced Energy [R]evolution scenario, strong growth in the renewable sector leads to an increase of 26% in total energy sector jobs by 2020, and job numbers are nearly 70% above 2015 levels in 2025. Job numbers continue to rise after 2025, to reach 20.1 million by 2030.

Renewable energy accounts for 87% of energy jobs by 2030. The greatest share are in biomass (24%), followed by solar PV and wind energy.

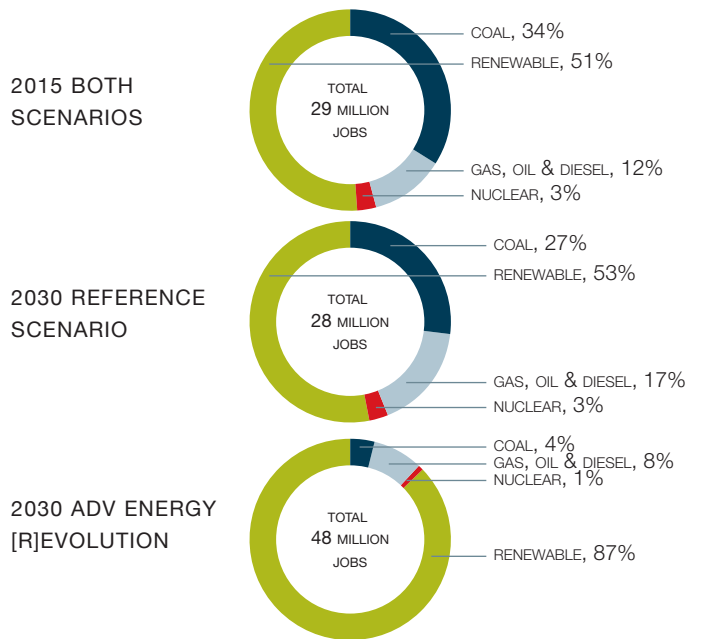
**FIGURE 6.1.10 | GLOBAL: DEVELOPMENT OF INVESTMENTS FOR RENEWABLE HEAT GENERATION TECHNOLOGIES – REFERENCE, ENERGY [R]EVOLUTION, ADVANCED ENERGY [R]EVOLUTION SCENARIOS**



**FIGURE 6.1.11 | GLOBAL: EMPLOYMENT IN THE ENERGY SECTOR UNDER THE REFERENCE AND ADVANCED ENERGY [R]EVOLUTION SCENARIO**



**FIGURE 6.1.12 | GLOBAL: GLOBAL PROPORTION OF FOSSIL FUEL AND RENEWABLE EMPLOYMENT IN 2015 AND 2030**



**TABLE 6.1.4 | GLOBAL: TOTAL EMPLOYMENT IN THE ENERGY SECTOR IN MILLION JOBS**

	2015	2020	REFERENCE SCENARIO		ADVANCED E[R] SCENARIO		
			2025	2030	2020	2025	2030
<b>BY FUEL</b>							
COAL	9.76	9.67	8.63	7.70	4.80	3.28	1.97
GAS, OIL & DIESEL	3.58	4.16	4.56	4.67	4.00	4.18	3.98
NUCLEAR	0.73	0.86	0.83	0.74	0.52	0.52	0.51
RENEWABLES	14.62	15.41	15.59	14.84	26.91	38.68	41.56
<b>TOTAL JOBS</b>	<b>28.69</b>	<b>30.11</b>	<b>29.62</b>	<b>27.95</b>	<b>36.24</b>	<b>46.65</b>	<b>48.01</b>
<b>BY SECTOR</b>							
CONSTRUCTION AND INSTALLATION	4.86	5.09	4.60	3.95	8.32	14.59	15.56
MANUFACTURING	2.38	2.44	2.23	1.91	5.49	8.87	9.58
OPERATIONS AND MAINTENANCE	3.23	3.94	4.30	4.27	4.82	6.96	9.00
FUEL SUPPLY (DOMESTIC)	17.76	18.12	17.93	17.27	17.27	15.97	13.67
COAL AND GAS EXPORT	0.47	0.52	0.54	0.57	0.34	0.26	0.20
<b>TOTAL JOBS (MILLION)</b>	<b>28.69</b>	<b>30.11</b>	<b>29.62</b>	<b>27.95</b>	<b>36.24</b>	<b>46.65</b>	<b>48.01</b>
<b>BY TECHNOLOGY</b>							
COAL	9.76	9.67	8.63	7.70	4.80	3.28	1.97
GAS, OIL & DIESEL	3.58	4.16	4.56	4.67	4.00	4.18	3.98
NUCLEAR	0.73	0.86	0.83	0.74	0.52	0.52	0.51
BIOMASS	10.97	11.85	12.05	11.76	12.07	12.55	11.54
HYDRO	1.45	1.46	1.47	1.29	1.01	0.83	0.71
WIND	0.70	0.72	0.76	0.65	4.22	6.91	8.18
PV	1.01	0.87	0.84	0.66	6.69	11.04	10.32
GEOTHERMAL POWER	0.03	0.03	0.03	0.03	0.18	0.30	0.39
SOLAR THERMAL POWER	0.03	0.04	0.05	0.08	0.45	1.66	2.66
OCEAN	0.00	0.00	0.00	0.01	0.23	0.45	0.65
SOLAR - HEAT	0.36	0.37	0.34	0.31	1.59	3.94	5.64
GEOTHERMAL & HEAT PUMP	0.07	0.05	0.04	0.04	0.48	0.99	1.46
<b>TOTAL JOBS (MILLION)</b>	<b>28.7</b>	<b>30.1</b>	<b>29.6</b>	<b>28.0</b>	<b>36.2</b>	<b>46.7</b>	<b>48.0</b>

### 6.1.8 TRANSPORT

A key target is to introduce incentives for people to drive smaller cars and buy new, more efficient vehicle concepts. In addition, it is vital to shift transport use to efficient modes like rail, light rail and buses, especially in the expanding large metropolitan areas. Along with rising prices for fossil fuels, these changes reduce the further growth in car sales projected under the Reference scenario. Due to population increase, GDP growth and higher living standards, energy demand from the transport sector is expected to increase in the Reference scenario by around 65% to 1480,00 PJ/a in 2050. In the basic Energy [R]evolution scenario, efficiency measures and modal shifts will save 53% (78,700 PJ/a) in 2050 compared to the Reference scenario.

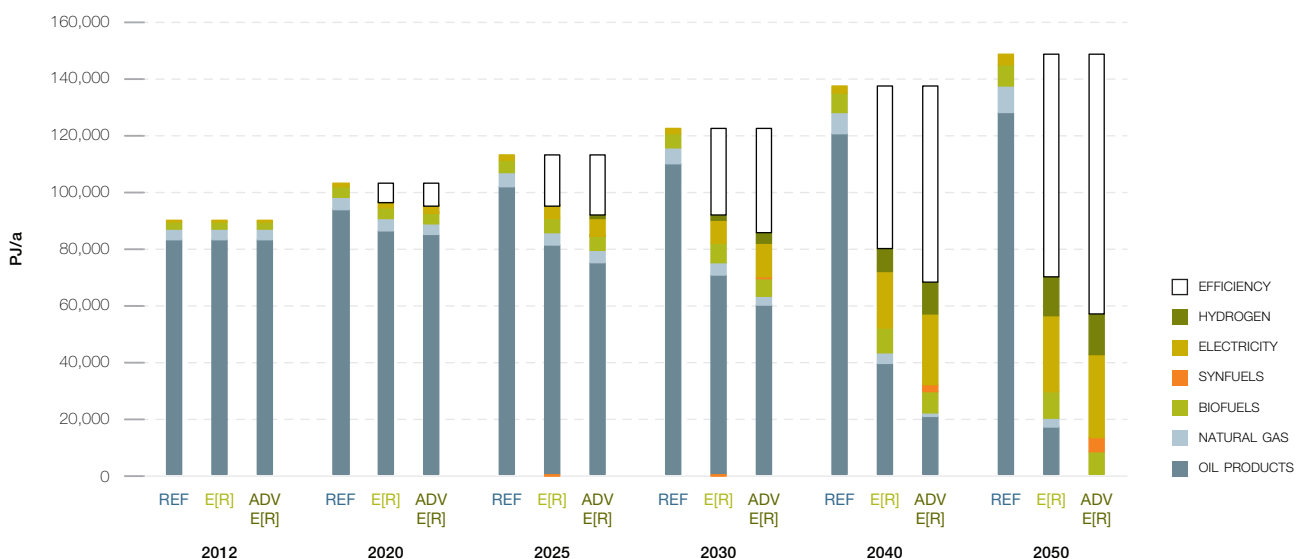
Additional modal shifts and technology switches lead to even higher energy savings in the Advanced scenario of 62% (92,000 PJ/a) in 2050 compared to the Reference scenario. Highly efficient propulsion technology with hybrid, plug-in hybrid and battery-electric power trains will bring about large efficiency gains. By 2030, electricity will provide 9% of the transport sector's total energy demand in the Energy [R]evolution, while in 2050 the share will be 39% (14%/52% in the Advanced scenario). Hydrogen and other synthetic fuels generated using renewable electricity are complementary options to further increase the renewable share in the transport sector. In 2050, up to 14,000 PJ/a of hydrogen is used in the transport sector for the Advanced Energy [R]evolution scenario. A global maximum of 9,300 PJ/a of biofuels is used in the basic Energy [R]evolution in 2050 while in the Advanced case consumption is lower (around 8,000 PJ/a).

**TABLE 6.1.5 | GLOBAL: PROJECTION OF TRANSPORT ENERGY DEMAND BY MODE IN THE REFERENCE AND THE ENERGY [R]EVOLUTION SCENARIOS** IN PJ/a

		2012	2020	2030	2040	2050
RAIL	REF	2,766	3,335	3,517	3,887	4,260
	E[R]	2,766	3,110	3,338	3,631	3,751
	ADV	2,766	3,278	4,718	6,774	8,356
ROAD	REF	78,688	98,701	107,510	120,944	130,313
	E[R]	78,688	83,781	79,473	67,361	57,356
	ADV	78,688	82,720	72,094	53,463	41,487
DOMESTIC AVIATION	REF	4,120	5,512	5,943	6,730	7,573
	E[R]	4,120	4,683	4,712	4,667	5,004
	ADV	4,120	4,636	4,423	3,885	3,602
DOMESTIC NAVIGATION	REF	2,173	2,707	2,963	3,269	3,470
	E[R]	2,173	2,492	2,728	2,849	2,860
	ADV	2,173	2,492	2,698	2,739	2,700
TOTAL	REF	87,748	110,256	119,934	134,829	145,616
	E[R]	87,748	94,065	90,252	78,509	68,972
	ADV	87,748	93,125	83,934	66,862	56,145

6

**FIGURE 6.1.13 | GLOBAL: FINAL ENERGY CONSUMPTION IN TRANSPORT UNDER THE SCENARIOS**



### 6.1.9 DEVELOPMENT OF CO<sub>2</sub> EMISSIONS

Whilst World's emissions of CO<sub>2</sub> will increase by 56% between 2012 and 2050 under the Reference scenario, under the Energy [R]evolution scenario they will decrease from 30,470 million tonnes in 2012 to 4,360 million tonnes in 2050. Annual per capita emissions will drop from 4.3 tonne to 0.5 tonne. In spite of the abstinence of nuclear power production and increasing power demand, CO<sub>2</sub> emissions will decrease in the electricity sector. In the long run efficiency gains and the increased use of renewable electricity in vehicles strongly reduce emissions in the transport sector as well. With a 31% share of CO<sub>2</sub>, the Industry sector will be the largest source of emissions in 2050 in the basic Energy [R]evolution scenario. By 2050, World's CO<sub>2</sub> emissions are 80% below 1990 levels in the Energy [R]evolution scenario while energy consumption is fully decarbonised in the Advanced case.

### 6.1.10 PRIMARY ENERGY CONSUMPTION

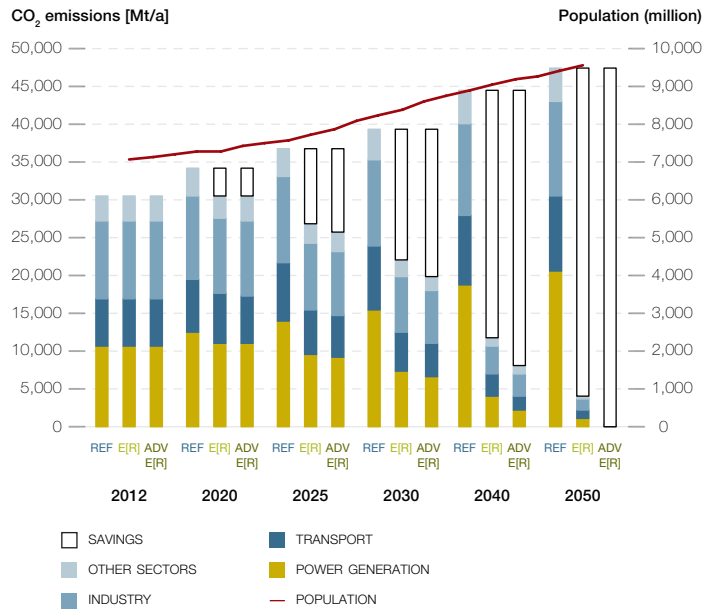
Taking into account the assumptions discussed above, the resulting primary energy consumption under the Energy [R]evolution scenarios is shown in Figure 6.1.14. Under the basic Energy [R]evolution scenario, primary energy demand will decrease by 19% from today's 534,870 PJ/a to around 433,000 PJ/a (excluding non-energy consumption).

Compared to the Reference scenario, overall primary energy demand will be reduced by 50% in 2050 under the Energy [R]evolution scenario (Reference scenario: around 860,000 PJ in 2050). The Advanced scenario results due to additional conversion losses in a primary energy consumption of around 450,000 PJ in 2050.

The Energy [R]evolution scenarios aim to phase out coal and oil as fast as technically and economically possible by

**FIGURE 6.1.15 | GLOBAL: DEVELOPMENT OF CO<sub>2</sub> EMISSIONS BY SECTOR UNDER THE ENERGY [R]EVOLUTION SCENARIOS**

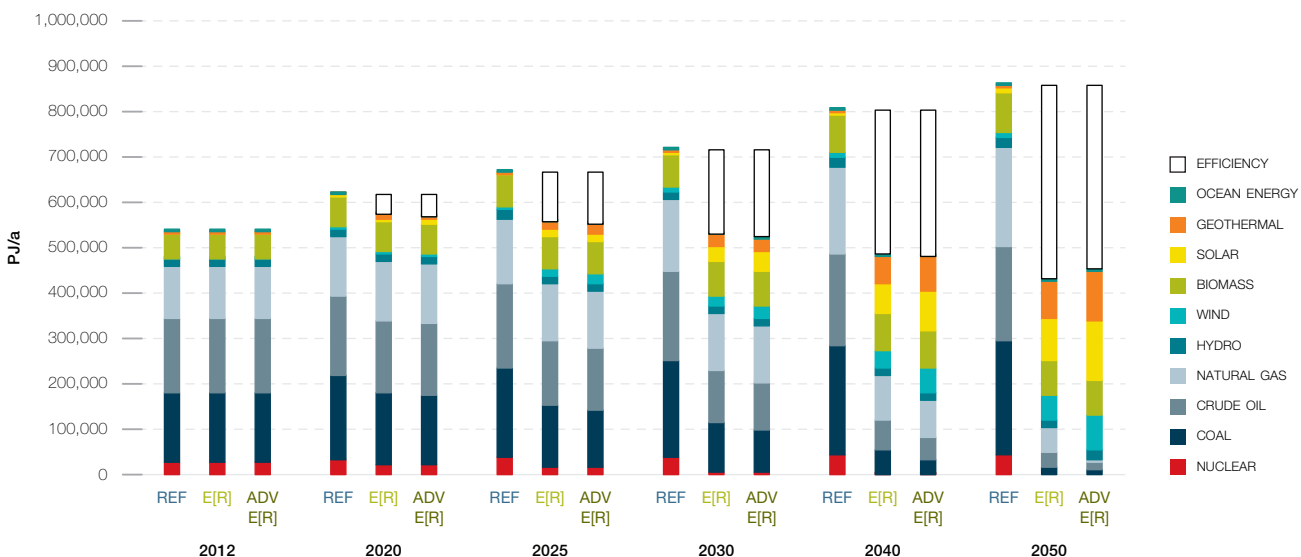
'SAVINGS' = REDUCTION COMPARED TO THE REFERENCE SCENARIO



expansion of renewable energies and a fast introduction of very efficient vehicle concepts in the transport sector to replace oil based combustion engines. This leads to an overall renewable primary energy share of 33% in 2030 and 76% in 2050 in the basic Energy [R]evolution and of more than 92% in 2050 in the Advanced case (incl. non-energy consumption). In contrast to the Reference scenario, no new nuclear power plants will be built worldwide in the Energy [R]evolution scenarios.

**FIGURE 6.1.14 | GLOBAL: PROJECTION OF TOTAL PRIMARY ENERGY DEMAND (PED) BY ENERGY CARRIER**

INCLUDING ELECTRICITY IMPORT BALANCE – REFERENCE, ENERGY [R]EVOLUTION, ADVANCED ENERGY [R]EVOLUTION SCENARIOS



**TABLE 6.1.6 | GLOBAL: ACCUMULATED INVESTMENT COSTS FOR ELECTRICITY GENERATION AND FUEL COST SAVINGS UNDER THE ENERGY [R]EVOLUTION SCENARIO COMPARED TO THE REFERENCE SCENARIO**

ACCUMULATED INVESTMENT COSTS DIFFERENCE REF MINUS E[R]	UNIT	2012-2020	2021-2030	2031-2040	2041-2050	2012-2050	2012 - 2050 AVERAGE PER YEAR
CONVENTIONAL (FOSSIL + NUCLEAR)	BILLION \$	906.2	2,400.5	2,559.9	2,739.9	8,606.5	220.7
RENEWABLES (INCL. CHP)	BILLION \$	-1,530.0	-8,308.7	-10,579.9	-11,945.4	-32,363.9	-829.8
<b>TOTAL</b>	<b>BILLION \$</b>	<b>-623.8</b>	<b>-5,908.2</b>	<b>-8,020.0</b>	<b>-9,205.5</b>	<b>-23,757.4</b>	<b>-609.2</b>
<b>ACCUMULATED FUEL COST SAVINGS</b>							
SAVINGS CUMULATIVE E[R] VERSUS REF							
FUEL OIL	BILLION \$	56.1	475.7	753.4	618.7	1,904.0	48.8
GAS	BILLION \$	-125.0	1,408.6	5,585.4	10,882.4	17,751.4	455.2
HARD COAL	BILLION \$	216.7	2,281.2	5,590.2	7,964.9	16,053.0	411.6
LIGNITE	BILLION \$	32.5	253.7	442.3	562.0	1,290.5	33.1
NUCLEAR ENERGY	BILLION \$	63.4	384.2	698.5	945.4	2,091.4	53.6
<b>TOTAL</b>	<b>BILLION \$</b>	<b>243.7</b>	<b>4,803.4</b>	<b>13,069.8</b>	<b>20,973.3</b>	<b>39,090.4</b>	<b>1,002.3</b>

**TABLE 6.1.7 | GLOBAL: ACCUMULATED INVESTMENT COSTS FOR RENEWABLE HEAT GENERATION UNDER THE ENERGY [R]EVOLUTION SCENARIO COMPARED TO THE REFERENCE SCENARIO**

ACCUMULATED INVESTMENT COSTS DIFFERENCE REF MINUS E[R]	UNIT	2012-2020	2021-2030	2031-2040	2041-2050	2012-2050	2012 - 2050 AVERAGE PER YEAR
RENEWABLES	BILLION \$	458.8	2,567.6	4,788.6	4,366.4	12,181.3	312.3

**TABLE 6.1.8 | GLOBAL: ACCUMULATED INVESTMENT COSTS FOR ELECTRICITY GENERATION AND FUEL COST SAVINGS UNDER THE ADVANCED ENERGY [R]EVOLUTION SCENARIO COMPARED TO THE REFERENCE SCENARIO**

ACCUMULATED INVESTMENT COSTS DIFFERENCE REF MINUS ADVANCED E[R]	UNIT	2012-2020	2021-2030	2031-2040	2041-2050	2012-2050	2012 - 2050 AVERAGE PER YEAR
CONVENTIONAL (FOSSIL + NUCLEAR)	BILLION \$	987.3	2,448.9	2,441.1	2,528.7	8,406.0	215.5
RENEWABLES (INCL. CHP)	BILLION \$	-2,014.1	-11,835.8	-16,264.6	-18,555.9	-48,670.4	-1,248.0
<b>TOTAL</b>	<b>BILLION \$</b>	<b>-1,026.9</b>	<b>-9,386.9</b>	<b>-13,823.5</b>	<b>-16,027.1</b>	<b>-40,264.5</b>	<b>-1,032.4</b>
<b>ACCUMULATED FUEL COST SAVINGS</b>							
SAVINGS CUMULATIVE ADVANCED E[R] VERSUS REF							
FUEL OIL	BILLION \$	51.5	483.3	769.7	633.4	1,937.9	49.7
GAS	BILLION \$	-113.0	1,502.4	6,057.6	12,315.0	19,761.9	506.7
HARD COAL	BILLION \$	232.0	2,449.7	5,960.2	8,299.8	16,941.7	434.4
LIGNITE	BILLION \$	32.5	253.7	442.3	562.2	1,290.8	33.1
NUCLEAR ENERGY	BILLION \$	63.4	384.2	698.5	945.4	2,091.4	53.6
<b>TOTAL</b>	<b>BILLION \$</b>	<b>266.4</b>	<b>5,073.2</b>	<b>13,928.3</b>	<b>22,755.8</b>	<b>42,023.8</b>	<b>1,077.5</b>

**TABLE 6.1.9 | GLOBAL: ACCUMULATED INVESTMENT COSTS FOR RENEWABLE HEAT GENERATION UNDER THE ADVANCED ENERGY [R]EVOLUTION SCENARIO COMPARED TO THE REFERENCE SCENARIO**

ACCUMULATED INVESTMENT COSTS DIFFERENCE REF MINUS ADVANCED E[R]	UNIT	2012-2020	2021-2030	2031-2040	2041-2050	2012-2050	2012 - 2050 AVERAGE PER YEAR
RENEWABLES	BILLION \$	458.8	2,570.7	4,929.7	4,631.6	12,590.9	322.8

## 6.2 OECD NORTH AMERICA

### 6.2.1 FINAL ENERGY DEMAND BY SECTOR

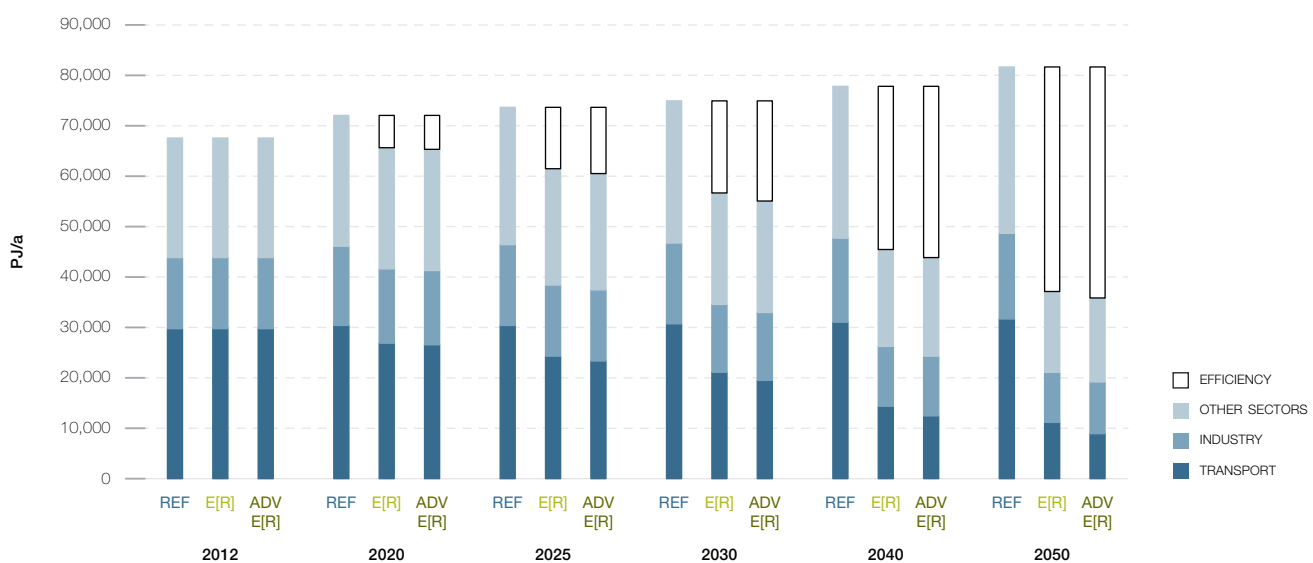
Combining the projections on population development, GDP growth and energy intensity results in future development pathways for OECD North America's final energy demand. These are shown in Figure 6.2.1 for the Reference and Energy [R]evolution scenarios. Under the Reference scenario, total final energy demand increases by 20% from the current 67,800 PJ/a to 81,600 PJ/a in 2050. In the basic Energy [R]evolution scenario, final energy demand decreases by 45% compared to current consumption and is expected to reach 37,300 PJ/a by 2050. The Advanced scenario results in some additional reductions due to a higher share of electric cars.

Under both Energy [R]evolution scenarios, due to economic growth, increasing living standards and electrification of the transport sector, overall electricity demand is expected to increase despite efficiency gains in all sectors (see Figure 6.2.2). Total electricity demand will rise from about 4,460 TWh/a to 4,610 TWh/a by 2050 in the basic Energy [R]evolution scenario. Compared to the Reference scenario, efficiency measures in the industry, residential and service sectors avoid the generation of about 3,650 TWh/a.

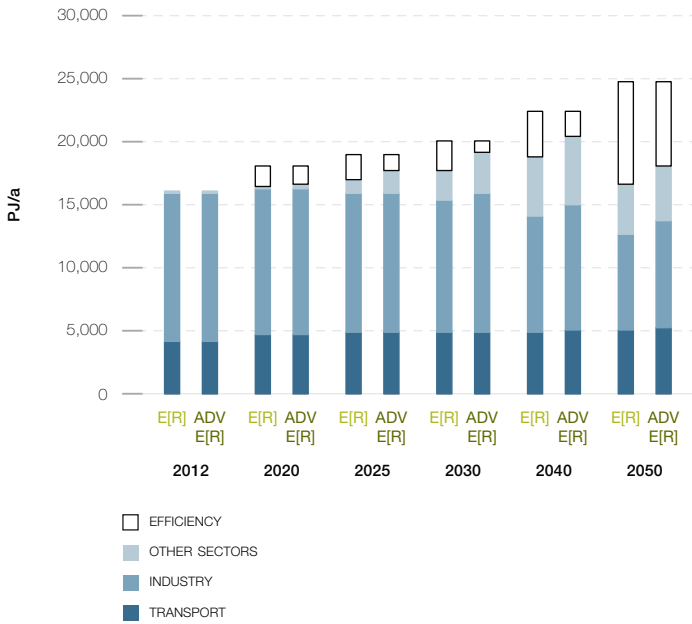
This reduction can be achieved in particular by introducing highly efficient electronic devices using the best available technology in all demand sectors. The transformation to a carbon free energy system in the Advanced scenario will further increase the electricity demand in 2050 up to 5,000 TWh/a. Electricity will become the major renewable 'primary' energy, not only for direct use for various purposes but also for the generation of synthetic fuels for fossil fuels substitution. Around 1,180 TWh are used in 2050 for electric vehicles and rail transport in 2050 in the Advanced scenario, around 900 TWh for hydrogen and 500 TWh for synthetic liquid fuel generation for the transport sector (excluding bunkers).

Efficiency gains in the heating sector are large as well. Under the Energy [R]evolution scenarios, consumption equivalent to about 7,400 PJ/a is avoided through efficiency gains by 2050 compared to the Reference scenario. As a result of energy-related renovation of the existing stock of residential buildings, the introduction of low energy standards and 'passive climatisation' for new buildings, as well as highly efficient air conditioning systems, enjoyment of the same comfort and energy services will be accompanied with much lower future energy demand.

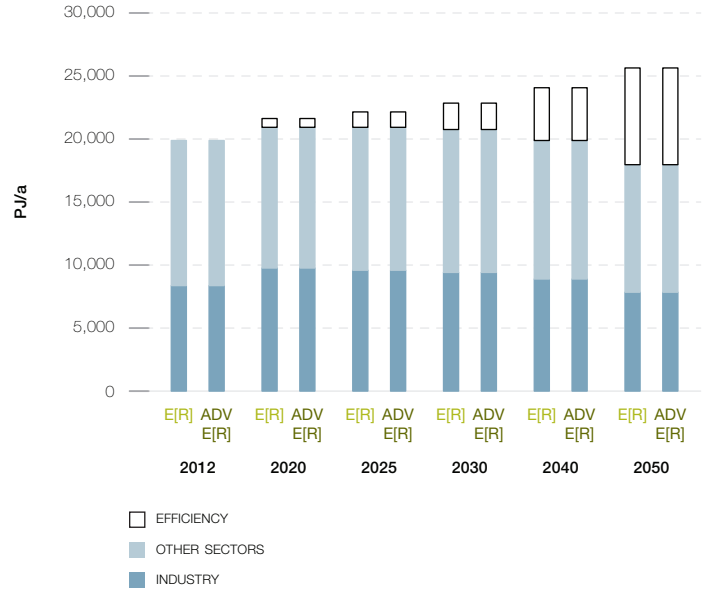
**FIGURE 6.2.1 | OECD NORTH AMERICA: PROJECTION OF TOTAL FINAL ENERGY DEMAND BY SECTOR – REFERENCE, ENERGY [R]EVOLUTION, ADVANCED ENERGY [R]EVOLUTION SCENARIOS** WITHOUT NON-ENERGY USE AND HEAT FROM CHP AUTOPRODUCERS



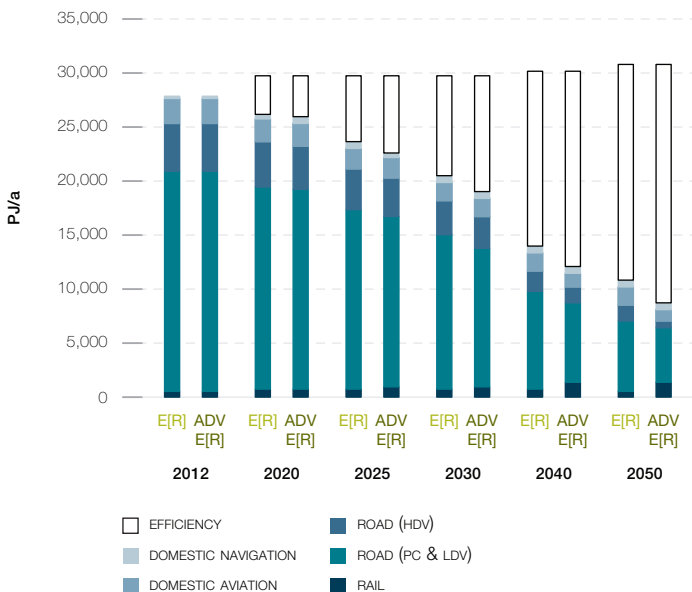
**FIGURE 6.2.2 | OECD NORTH AMERICA: DEVELOPMENT OF ELECTRICITY DEMAND BY SECTOR IN THE ENERGY [R]EVOLUTION SCENARIOS**



**FIGURE 6.2.4 | OECD NORTH AMERICA: DEVELOPMENT OF FINAL ENERGY DEMAND FOR HEAT BY SECTOR IN THE ENERGY [R]EVOLUTION SCENARIOS**



**FIGURE 6.2.3 | OECD NORTH AMERICA: DEVELOPMENT OF THE FINAL ENERGY DEMAND FOR TRANSPORT BY SECTOR IN THE ENERGY [R]EVOLUTION SCENARIOS**



### 6.2.2 ELECTRICITY GENERATION

The development of the electricity supply sector is characterised by a dynamically growing renewable energy market and an increasing share of renewable electricity. This trend will more than compensate for the phasing out of nuclear power production in the Energy [R]evolution scenarios, continuously reducing the number of fossil fuel-fired power plants as well. By 2050, 95% of the electricity produced in OECD North America will come from renewable energy sources in the basic Energy [R]evolution scenario. ‘New’ renewables – mainly wind, PV, CSP and geothermal energy – will contribute 80% to the total electricity generation. Already by 2020 the share of renewable electricity production will be 32% and 66% by 2030. The installed capacity of renewables will reach about 1,620 GW in 2030 and 2,350 GW by 2050.

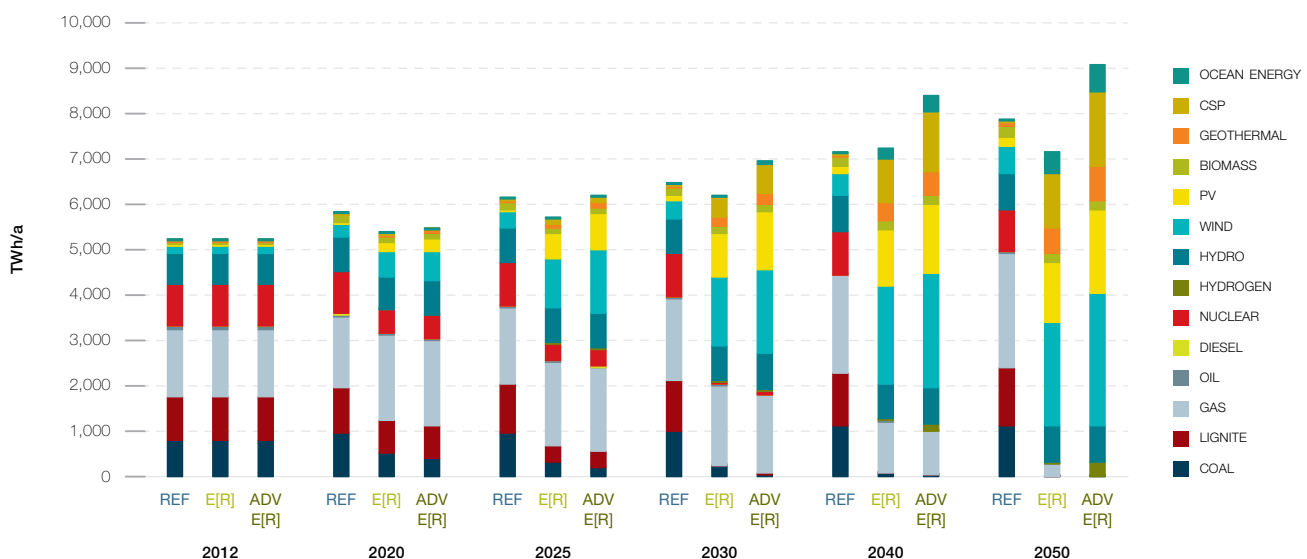
A 100% electricity supply from renewable energy resources in the Advanced scenario leads to around 3,100 GW installed generation capacity in 2050.

Table 6.2.1 shows the comparative evolution of the different renewable technologies in OECD North America over time. Up to 2020 wind and PV will become the main contributors to the growing market share. After 2020, the continuing growth of wind and PV will be complemented by electricity from solar thermal, geothermal and ocean energy. The Energy [R]evolution scenarios will lead to a high share of fluctuating power generation sources (PV, wind and ocean) of already 41% to 47% by 2030 and 57% to 59% by 2050. Therefore, smart grids, demand side management (DSM), energy storage capacities and other options need to be expanded in order to increase the flexibility of the power system for grid integration, load balancing and a secure supply of electricity.

**TABLE 6.2.1 | OECD NORTH AMERICA: PROJECTION OF RENEWABLE ELECTRICITY GENERATION CAPACITY UNDER THE REFERENCE AND THE ENERGY [R]EVOLUTION SCENARIOS IN GW**

		2012	2020	2030	2040	2050
HYDRO	REF	204	208	217	214	214
	E[R]	204	213	225	230	233
	ADV	204	213	227	239	257
BIOMASS	REF	16	24	31	37	45
	E[R]	16	21	27	33	62
	ADV	16	21	27	33	37
WIND	REF	67	109	144	175	207
	E[R]	67	206	544	730	763
	ADV	67	248	661	852	971
GEOTHERMAL	REF	4	6	7	8	10
	E[R]	4	8	31	56	80
	ADV	4	9	38	95	134
PV	REF	9	40	70	99	133
	E[R]	9	145	668	850	869
	ADV	9	197	893	1 038	1,224
CSP	REF	1	5	9	11	14
	E[R]	1	5	101	181	198
	ADV	1	7	149	248	286
OCEAN	REF	0	0	1	2	4
	E[R]	0	5	26	96	149
	ADV	0	6	33	122	193
TOTAL	REF	300	391	479	547	626
	E[R]	300	604	1,621	2,175	2,353
	ADV	300	702	2,028	2,626	3,102

**FIGURE 6.2.5 | OECD NORTH AMERICA: DEVELOPMENT OF ELECTRICITY GENERATION STRUCTURE – REFERENCE, ENERGY [R]EVOLUTION, ADVANCED ENERGY [R]EVOLUTION SCENARIOS**





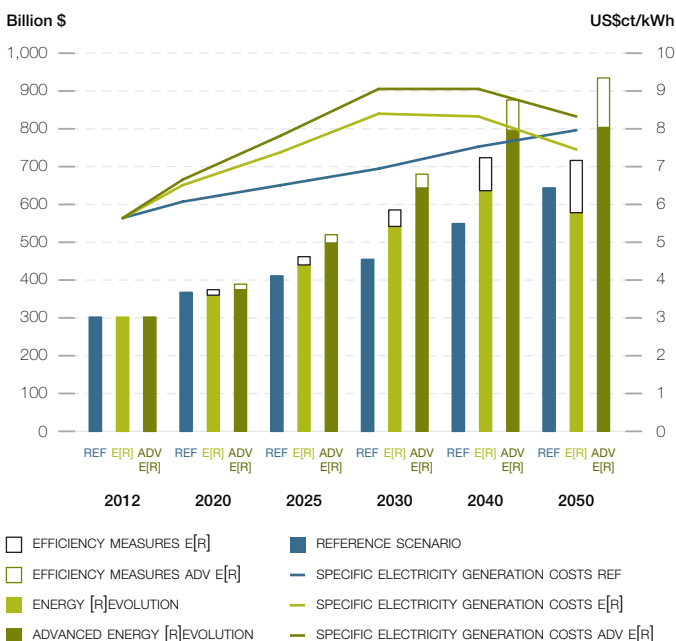
### 6.2.3 FUTURE COSTS OF ELECTRICITY GENERATION

Figure 6.2.6 shows that the introduction of renewable technologies under both Energy [R]evolution scenarios increases the future costs of electricity generation compared to the Reference scenario until 2040. This difference in full cost of generation will be less than 1.5 US\$/kWh in the basic Energy [R]evolution and about 2.1 US\$/kWh in the Advanced scenario, without taking into account integration costs for storage or other load-balancing measures. Because of increasing prices for conventional fuels, electricity generation costs will become economically favourable after 2040 under the Energy [R]evolution scenario. By 2050, in the Energy [R]evolution the cost will be 0.5 US\$/kWh below and in the Advanced scenario 0.4 US\$/kWh above those in the Reference case.

Under the Reference scenario, on the other hand, growth in demand and increasing fossil fuel prices result in total electricity supply costs rising from today's US\$ 303 billion per year to more than US\$ 645 billion in 2050, compared to US\$ 583 billion in the basic and US\$ 808 billion in the Advanced Energy [R]evolution scenario. Figure 6.2.6 shows that both Energy [R]evolution scenarios not only comply with OECD North America's CO<sub>2</sub> reduction targets, but also help stabilise energy costs and relieve the economic pressure on society.

Increasing energy efficiency and shifting energy supply to renewables lead to long term costs for electricity supply that are more than 10% lower in the basic Energy [R]evolution scenario than in the Reference scenario. The Advanced scenario with 100% renewable power in supply costs 25% higher than the Reference case, but a reduction of CO<sub>2</sub> intensity to zero.

**FIGURE 6.2.6 | OECD NORTH AMERICA: DEVELOPMENT OF TOTAL ELECTRICITY SUPPLY COSTS & OF SPECIFIC ELECTRICITY GENERATION COSTS IN THE SCENARIOS**



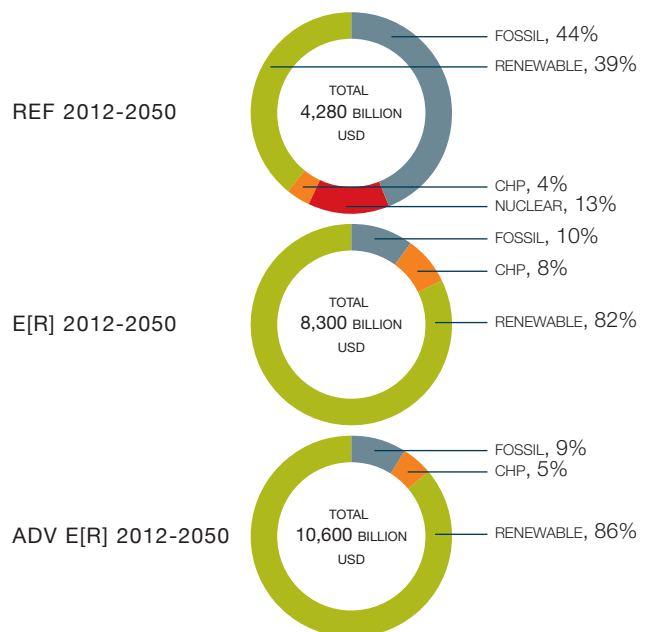
### 6.2.4 FUTURE INVESTMENTS IN THE POWER SECTOR

Around US\$ 8,300 billion is required in investment for the Energy [R]evolution scenario to become reality (including investments for replacement after the economic lifetime of the plants) - approximately US\$ 213 billion per year, US\$ 4,020 billion more than in the Reference scenario (US\$ 4,280 billion). Investments for the Advanced scenario sum up to US\$ 10,620 billion until 2050, on average US\$ 272 billion per year, including high investments for additional power plants for the production of synthetic fuels. Under the Reference scenario, the levels of investment in conventional power plants add up to almost 57% while approximately 43% would be invested in renewable energies and cogeneration until 2050.

Under the Energy [R]evolution scenarios, however, OECD North America would shift almost 90%/91% of the entire investment towards renewables and cogeneration, respectively. By 2030, the fossil fuel share of power sector investment would be focused mainly on gas power plants.

Because renewable energy has no fuel costs, the fuel cost savings in the basic Energy [R]evolution scenario reach a total of US\$ 4,390 billion up to 2050, US\$ 113 billion per year. The total fuel cost savings therefore would cover 110% of the total additional investments compared to the Reference scenario. Fuel cost savings in the Advanced scenario are even higher and add up to US\$ 4,680 billion, or US\$ 120 billion per year. Renewable energy sources would then go on to produce electricity without any further fuel costs beyond 2050, while costs for coal and gas will continue to be a burden on national economies.

**FIGURE 6.2.7 | OECD NORTH AMERICA: INVESTMENT SHARES - REFERENCE VERSUS ENERGY [R]EVOLUTION SCENARIOS**



### 6.2.5 ENERGY SUPPLY FOR HEATING

Today, renewables meet around 11% of OECD North America's energy demand for heating, the main contribution coming from the use of biomass. Dedicated support instruments are required to ensure a dynamic development in particular for renewable technologies for buildings and renewable process heat production. In the basic Energy [R]evolution scenario, renewables already provide 39% of OECD North America's total heat demand in 2030 and 89% in 2050.

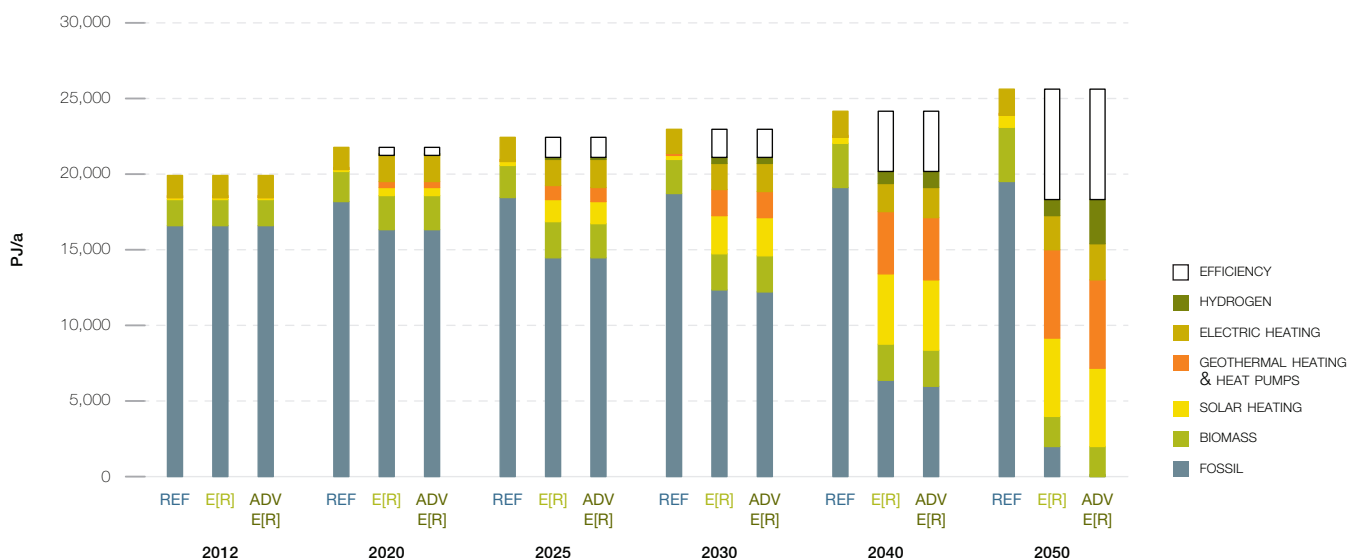
- The efficiency measures help to reduce the currently growing energy demand for heating by 29 % in 2050 (relative to the Reference scenario), in spite of improving living standards and economic growth.
- In the industry sector solar collectors, geothermal energy (incl. heat pumps) as well as electricity and hydrogen from renewable sources are increasingly substituting for fossil fuel-fired systems.
- A shift from coal and oil to natural gas in the remaining conventional applications leads to a further reduction of CO<sub>2</sub> emissions.

Table 6.2.2 shows the development of different renewable technologies for heating in OECD North America over time. Up to 2030 biomass remains the main contributor of the growing market share. After 2030, the continuing growth of solar collectors and a growing share of geothermal and environmental heat as well as heat from renewable hydrogen will further reduce the dependence on fossil fuels. The Advanced scenario results in a complete substitution of the remaining gas consumption by hydrogen generated from renewable electricity.

**TABLE 6.2.2 | OECD NORTH AMERICA: PROJECTION OF RENEWABLE HEAT SUPPLY UNDER THE REFERENCE AND BOTH ENERGY [R]EVOLUTION SCENARIOS** IN PJ/a

		2012	2020	2030	2040	2050
BIOMASS	REF	1,784	2,174	2,338	2,905	3,658
	E[R]	1,784	2,316	2,367	2,405	1,932
	ADV	1,784	2,316	2,367	2,405	1,932
SOLAR HEATING	REF	68	199	272	474	766
	E[R]	68	1,459	2,548	4,620	5,275
	ADV	68	1,472	2,561	4,675	5,292
GEOHERMAL HEAT AND HEAT PUMPS	REF	14	14	14	15	15
	E[R]	14	963	1,760	4,070	5,817
	ADV	14	963	1,760	4,070	5,813
HYDROGEN	REF	0	0	0	0	0
	E[R]	0	156	316	770	1,089
	ADV	0	229	398	1,095	2,928
TOTAL	REF	1,866	2,387	2,624	3,394	4,439
	E[R]	1,866	4,894	6,991	11,866	14,112
	ADV	1,866	4,980	7,086	12,245	15,965

**FIGURE 6.2.8 | OECD NORTH AMERICA: PROJECTION OF HEAT SUPPLY BY ENERGY CARRIER – REFERENCE, ENERGY [R]EVOLUTION, ADVANCED ENERGY [R]EVOLUTION SCENARIOS**



### 6.2.6 FUTURE INVESTMENTS IN THE HEATING SECTOR

Also in the heating sector the Energy [R]evolution scenarios would require a major revision of current investment strategies in heating technologies. In particular, solar thermal, geothermal and heat pump technologies need an enormous increase in installations if these potentials are to be tapped for the heating sector. The use of biomass for heating purposes - often traditional biomass today - will be substantially reduced in the Energy [R]evolution scenarios and replaced by more efficient and sustainable renewable heating technologies.

Renewable heating technologies are extremely variable, from low tech biomass stoves and unglazed solar collectors to very sophisticated enhanced geothermal and solar systems. Thus, it can only be roughly estimated that the Energy [R]evolution scenario in total requires around US\$ 3,550 billion to be invested in renewable heating technologies up to 2050 (including investments for replacement after the economic lifetime of the plants) - approximately US\$ 91 billion per year. The Advanced scenario assumes the same ambitious expansion of renewable technologies, while the main strategy in the scenario is the substitution of the remaining natural gas amounts with hydrogen or other synthetic fuels.

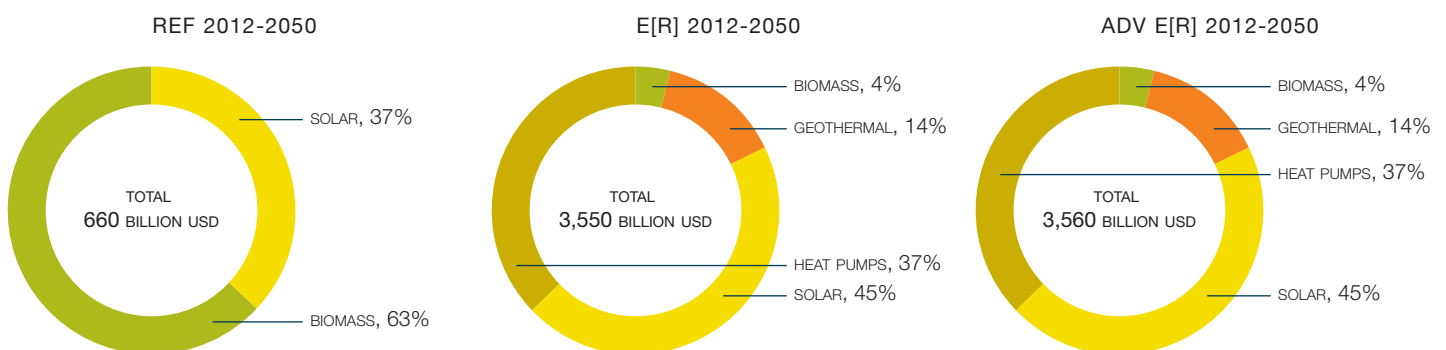
**TABLE 6.2.3 | OECD NORTH AMERICA: INSTALLED CAPACITIES FOR RENEWABLE HEAT GENERATION UNDER THE SCENARIOS** IN GW

		2012	2020	2030	2040	2050
BIOMASS	REF	293	343	396	450	511
	E[R]	293	347	307	223	97
	ADV	293	347	307	223	97
GEOTHERMAL	REF	0	0	0	0	0
	E[R]	0	13	67	170	235
	ADV	0	13	67	170	235
SOLAR HEATING	REF	20	37	80	140	226
	E[R]	20	166	715	1,265	1,417
	ADV	20	166	719	1,281	1,422
HEAT PUMPS	REF	2	2	2	2	2
	E[R]	2	35	186	435	626
	ADV	2	35	186	435	626
TOTAL*	REF	315	382	479	592	740
	E[R]	315	561	1,275	2,093	2,375
	ADV	315	561	1,279	2,109	2,380

\* Excluding direct electric heating.

6

**FIGURE 6.2.9 | OECD NORTH AMERICA: DEVELOPMENT OF INVESTMENTS FOR RENEWABLE HEAT GENERATION TECHNOLOGIES - REFERENCE, ENERGY [R]EVOLUTION, ADVANCED ENERGY [R]EVOLUTION SCENARIOS**



### 6.2.7 FUTURE EMPLOYMENT IN THE ENERGY SECTOR

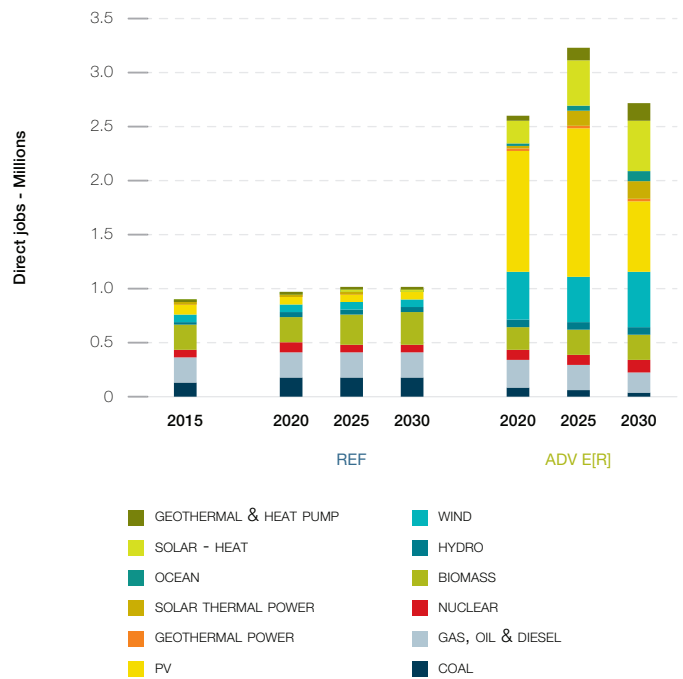
The Advanced Energy [R]evolution scenario results in more energy sector jobs in the OECD North America at every stage of the projection.

- There are 2.6 million energy sector jobs in the Advanced Energy [R]evolution in 2020, and 1 million in the Reference scenario.
- In 2025, there are 3.2 million jobs in the Advanced Energy [R]evolution scenario, and 1 million in the Reference scenario.
- In 2030, there are 2.7 million jobs in the Advanced Energy [R]evolution scenario and 1 million in the Reference scenario.

Figure 6.2.10 shows the change in job numbers in both scenarios for each technology between 2015 and 2030. Jobs in the Reference scenario increase very slightly over the period.

Exceptionally strong growth in the renewable sector leads to a sharp increase of 193% in energy sector jobs in the Advanced Energy [R]evolution scenario by 2020. After 2020 jobs in solar PV drop, but at 2030 jobs are still 205% above 2015 levels. Renewable energy accounts for 88% of energy jobs in 2030, with the majority in solar PV, followed by solar heating.

**FIGURE 6.2.10 | OECD NORTH AMERICA: EMPLOYMENT IN THE ENERGY SECTOR UNDER THE REFERENCE AND ADVANCED ENERGY [R]EVOLUTION SCENARIO**



**TABLE 6.2.4 | OECD NORTH AMERICA: TOTAL EMPLOYMENT IN THE ENERGY SECTOR IN THOUSAND JOBS**

	2015	2020	REFERENCE		ADVANCED ENERGY [R]EVOLUTION		
			2025	2030	2020	2025	2030
COAL	135	175	170	171	83	56	29
GAS, OIL & DIESEL	232	238	241	244	256	233	202
NUCLEAR	79	80	77	75	96	99	107
RENEWABLES	442	463	510	517	2,164	2,841	2,374
<b>TOTAL JOBS</b>	<b>888</b>	<b>956</b>	<b>998</b>	<b>1,007</b>	<b>2,600</b>	<b>3,229</b>	<b>2,712</b>
CONSTRUCTION AND INSTALLATION	108	120	123	106	1,029	1,336	963
MANUFACTURING	73	78	77	68	802	935	659
OPERATIONS AND MAINTENANCE	332	352	366	379	418	637	797
FUEL SUPPLY (DOMESTIC)	363	394	416	437	343.8	316	290
COAL AND GAS EXPORT	12	13	15	16	6	5	3
<b>TOTAL JOBS</b>	<b>888</b>	<b>956</b>	<b>998</b>	<b>1,007</b>	<b>2,600</b>	<b>3,229</b>	<b>2,712</b>

### 6.2.8 TRANSPORT

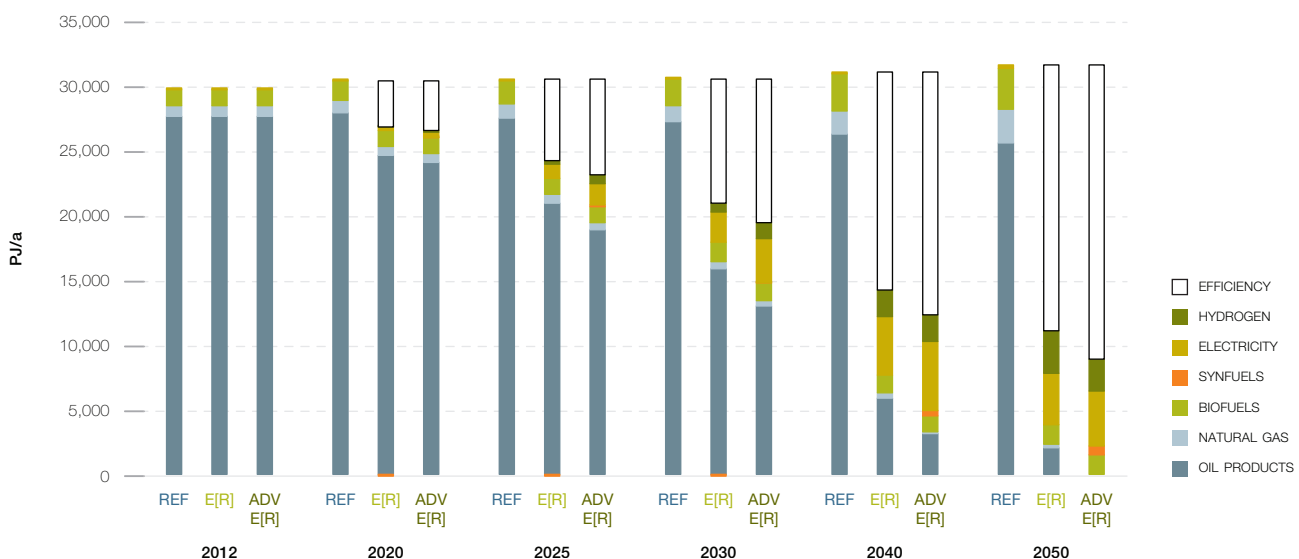
A key target in OECD North America is to introduce incentives for people to drive smaller cars and buy new, more efficient vehicle concepts. In addition, it is vital to shift transport use to efficient modes like rail, light rail and buses, especially in the large metropolitan areas. Along with rising prices for fossil fuels, these changes reduce the further growth in car sales projected under the Reference scenario. Due to population increase, GDP growth and higher living standards, energy demand from the transport sector is expected to slightly increase in the Reference scenario by around 7% to 31,710 PJ/a in 2050. In the basic Energy [R]evolution scenario, efficiency measures and modal shifts will save 65% (20,630 PJ/a) in 2050 compared to the Reference scenario.

Additional modal shifts and technology switches lead to even higher energy savings in the Advanced scenario of 72% (22,700 PJ/a) in 2050 compared to the Reference scenario. Highly efficient propulsion technology with hybrid, plug-in hybrid and battery-electric power trains will bring about large efficiency gains. By 2030, electricity will provide 11% of the transport sector's total energy demand in the Energy [R]evolution, while in 2050 the share will be 35% (47% in the Advanced scenario). Hydrogen and other synthetic fuels generated using renewable electricity are complementary options to further increase the renewable share in the transport sector. In 2050, up to 2,500 PJ/a of hydrogen is used in the transport sector for the Advanced Energy [R]evolution scenario.

**TABLE 6.2.5 | OECD NORTH AMERICA: PROJECTION OF TRANSPORT ENERGY DEMAND BY MODE IN THE REFERENCE AND THE ENERGY [R]EVOLUTION SCENARIOS IN PJ/a**

		2012	2020	2030	2040	2050
RAIL	REF	663	723	749	804	877
	E[R]	663	676	686	710	559
	ADV	663	743	1,043	1,401	1,399
ROAD	REF	25,564	26,090	26,039	26,275	26,487
	E[R]	25,564	22,925	17,497	11,049	7,927
	ADV	25,564	22,554	15,654	8,727	5,615
DOMESTIC AVIATION	REF	2,161	2,307	2,372	2,529	2,717
	E[R]	2,161	2,047	1,762	1,582	1,678
	ADV	2,161	2,026	1,639	1,249	1,091
DOMESTIC NAVIGATION	REF	550	589	602	630	657
	E[R]	550	566	598	637	696
	ADV	550	566	598	637	696
TOTAL	REF	28,938	29,708	29,762	30,237	30,738
	E[R]	28,938	26,214	20,543	13,978	10,860
	ADV	28,938	25,890	18,934	12,014	8,801

**FIGURE 6.2.11 | OECD NORTH AMERICA: FINAL ENERGY CONSUMPTION IN TRANSPORT UNDER THE SCENARIOS**



### 6.2.10 DEVELOPMENT OF CO<sub>2</sub> EMISSIONS

Whilst OECD North America's emissions of CO<sub>2</sub> will increase by 6% between 2012 and 2050 under the Reference scenario, under the Energy [R]evolution scenario they will decrease from 5,950 million tonnes in 2012 to 397 million tonnes in 2050. Annual per capita emissions will drop from 12.5 tonne to 0.7 tonne. In spite of the abstinence of nuclear power production and increasing power demand, CO<sub>2</sub> emissions will decrease in the electricity sector. In the long run efficiency gains and the increased use of renewable electricity in vehicles strongly reduce emissions in the transport sector as well.

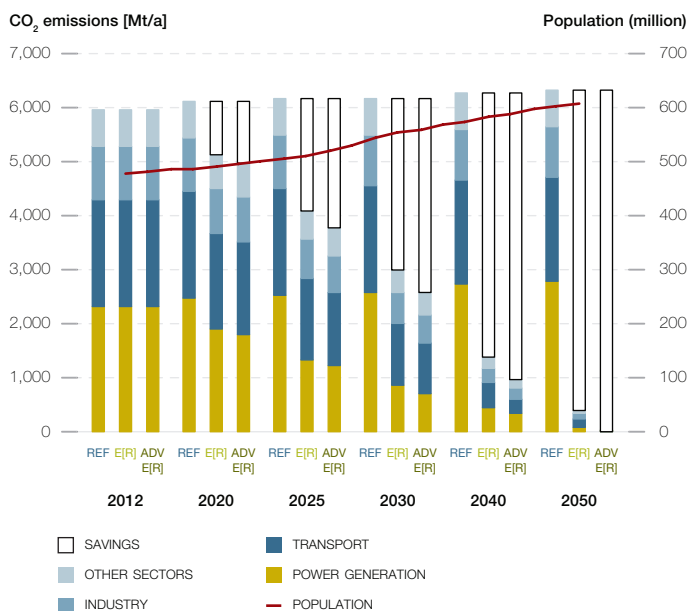
With a 40% share of CO<sub>2</sub>, the Transport sector will be the largest source of emissions in 2050 in the basic Energy [R]evolution scenario. By 2050, OECD North America's CO<sub>2</sub> emissions are around 90% below 1990 levels in the Energy [R]evolution scenario while energy consumption is fully decarbonised in the Advanced case.

### 6.2.11 PRIMARY ENERGY CONSUMPTION

Taking into account the assumptions discussed above, the resulting primary energy consumption under the Energy [R]evolution scenarios is shown in Figure 6.2.12. Under the basic Energy [R]evolution scenario, primary energy demand will decrease by 46% from today's 107,520 PJ/a to around 58,000 PJ/a. Compared to the Reference scenario, overall primary energy demand will be reduced by 54% in 2050 under the Energy [R]evolution scenario (Reference scenario: around 126,000 PJ in 2050). The Advanced Energy [R]evolution scenario results due to additional conversion losses in a primary energy consumption of around 61,100 PJ in 2050.

The Energy [R]evolution scenarios aim to phase out coal and oil as fast as technically and economically possible by expansion of

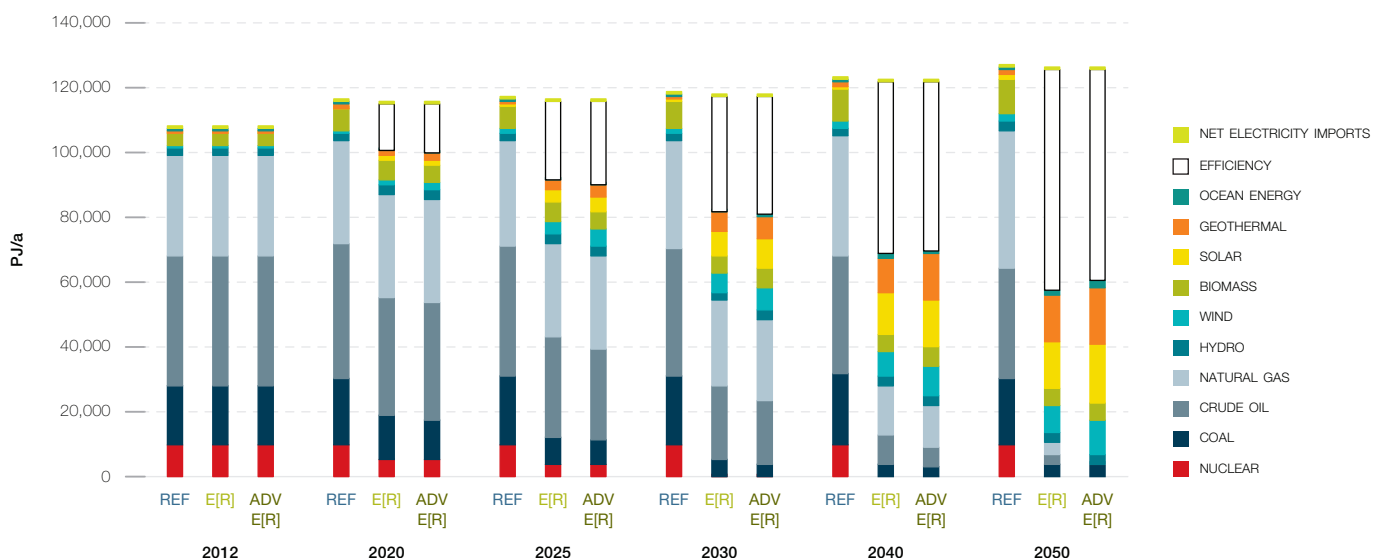
**FIGURE 6.2.13 | OECD NORTH AMERICA: DEVELOPMENT OF CO<sub>2</sub> EMISSIONS BY SECTOR UNDER THE ENERGY [R]EVOLUTION SCENARIOS** 'SAVINGS' = REDUCTION COMPARED TO THE REFERENCE SCENARIO



renewable energies and a fast introduction of very efficient vehicle concepts in the transport sector to replace oil based combustion engines. This leads to an overall renewable primary energy share of 34% in 2030 and 80% in 2050 in the basic Energy [R]evolution and of more than 92% in 2050 in the Advanced case (incl. non-energy consumption). In contrast to the Reference scenario, no new nuclear power plants will be built in OECD North America in the Energy [R]evolution scenarios.

**FIGURE 6.2.12 | OECD NORTH AMERICA: PROJECTION OF TOTAL PRIMARY ENERGY DEMAND (PED) BY ENERGY CARRIER**

INCLUDING ELECTRICITY IMPORT BALANCE – REFERENCE, ENERGY [R]EVOLUTION, ADVANCED ENERGY [R]EVOLUTION SCENARIOS



**TABLE 6.2.6 | OECD NORTH AMERICA: ACCUMULATED INVESTMENT COSTS FOR ELECTRICITY GENERATION AND FUEL COST SAVINGS UNDER THE ENERGY [R]EVOLUTION SCENARIO COMPARED TO THE REFERENCE SCENARIO**

ACCUMULATED INVESTMENT COSTS DIFFERENCE REF MINUS E[R]	UNIT	2012-2020	2021-2030	2031-2040	2041-2050	2012-2050	2012 - 2050 AVERAGE PER YEAR
CONVENTIONAL (FOSSIL + NUCLEAR)	BILLION \$	289.1	403.8	416.2	521.5	1,630.6	41.8
RENEWABLES (INCL. CHP)	BILLION \$	-467.8	-2,003.6	-1,667.9	-1,522.8	-5,662.0	-145.2
<b>TOTAL</b>	<b>BILLION \$</b>	<b>-178.8</b>	<b>-178.8</b>	<b>-1,599.8</b>	<b>-1,251.6</b>	<b>-1,001.3</b>	<b>-103.3</b>
<b>ACCUMULATED FUEL COST SAVINGS</b>							
SAVINGS CUMULATIVE E[R] VERSUS REF							
FUEL OIL	BILLION \$	6.9	25.0	40.6	24.5	97.0	2.5
GAS	BILLION \$	-31.5	31.4	492.0	1,289.3	1,781.2	45.7
HARD COAL	BILLION \$	95.3	309.9	471.0	520.2	1,396.4	35.8
LIGNITE	BILLION \$	20.7	134.9	209.7	233.4	598.6	15.3
NUCLEAR ENERGY	BILLION \$	24.1	103.8	175.6	215.8	519.3	13.3
<b>TOTAL</b>	<b>BILLION \$</b>	<b>115.4</b>	<b>605.0</b>	<b>1,388.8</b>	<b>2,283.2</b>	<b>4,392.4</b>	<b>112.6</b>

**TABLE 6.2.7 | OECD NORTH AMERICA: ACCUMULATED INVESTMENT COSTS FOR RENEWABLE HEAT GENERATION UNDER THE ENERGY [R]EVOLUTION SCENARIO COMPARED TO THE REFERENCE SCENARIO**

ACCUMULATED INVESTMENT COSTS DIFFERENCE REF MINUS E[R]	UNIT	2012-2020	2021-2030	2031-2040	2041-2050	2012-2050	2012 - 2050 AVERAGE PER YEAR
RENEWABLES	BILLION \$	224.4	615.4	1,144.3	903.9	2,888.0	74.1

**TABLE 6.2.8 | OECD NORTH AMERICA: ACCUMULATED INVESTMENT COSTS FOR ELECTRICITY GENERATION AND FUEL COST SAVINGS UNDER THE ADVANCED ENERGY [R]EVOLUTION SCENARIO COMPARED TO THE REFERENCE SCENARIO**

ACCUMULATED INVESTMENT COSTS DIFFERENCE REF MINUS ADVANCED E[R]	UNIT	2012-2020	2021-2030	2031-2040	2041-2050	2012-2050	2012 - 2050 AVERAGE PER YEAR
CONVENTIONAL (FOSSIL + NUCLEAR)	BILLION \$	337.3	402.6	329.7	471.4	1,541.1	39.5
RENEWABLES (INCL. CHP)	BILLION \$	-663.8	-2,715.7	-2,170.2	-2,340.4	-7,890.1	-202.3
<b>TOTAL</b>	<b>BILLION \$</b>	<b>-326.5</b>	<b>-2,313.1</b>	<b>-1,840.5</b>	<b>-1,869.0</b>	<b>-6,349.0</b>	<b>-162.8</b>
<b>ACCUMULATED FUEL COST SAVINGS</b>							
SAVINGS CUMULATIVE ADVANCED E[R] VERSUS REF							
FUEL OIL	BILLION \$	6.9	25.0	40.6	25.9	98.4	2.5
GAS	BILLION \$	-31.5	39.9	552.5	1,401.2	1,962.1	50.3
HARD COAL	BILLION \$	109.5	363.2	501.5	523.1	1,497.3	38.4
LIGNITE	BILLION \$	20.7	134.9	209.7	233.4	598.6	15.3
NUCLEAR ENERGY	BILLION \$	24.1	103.8	175.6	215.8	519.3	13.3
<b>TOTAL</b>	<b>BILLION \$</b>	<b>129.6</b>	<b>666.8</b>	<b>1,479.8</b>	<b>2,399.4</b>	<b>4,675.6</b>	<b>119.9</b>

**TABLE 6.2.9 | OECD NORTH AMERICA: ACCUMULATED INVESTMENT COSTS FOR RENEWABLE HEAT GENERATION UNDER THE ADVANCED ENERGY [R]EVOLUTION SCENARIO COMPARED TO THE REFERENCE SCENARIO**

ACCUMULATED INVESTMENT COSTS DIFFERENCE REF MINUS ADVANCED E[R]	UNIT	2012-2020	2021-2030	2031-2040	2041-2050	2012-2050	2012 - 2050 AVERAGE PER YEAR
RENEWABLES	BILLION \$	224.4	619.1	1,155.3	902.7	2,901.4	74.4

## 6.3 LATIN AMERICA

### 6.3.1 FINAL ENERGY DEMAND BY SECTOR

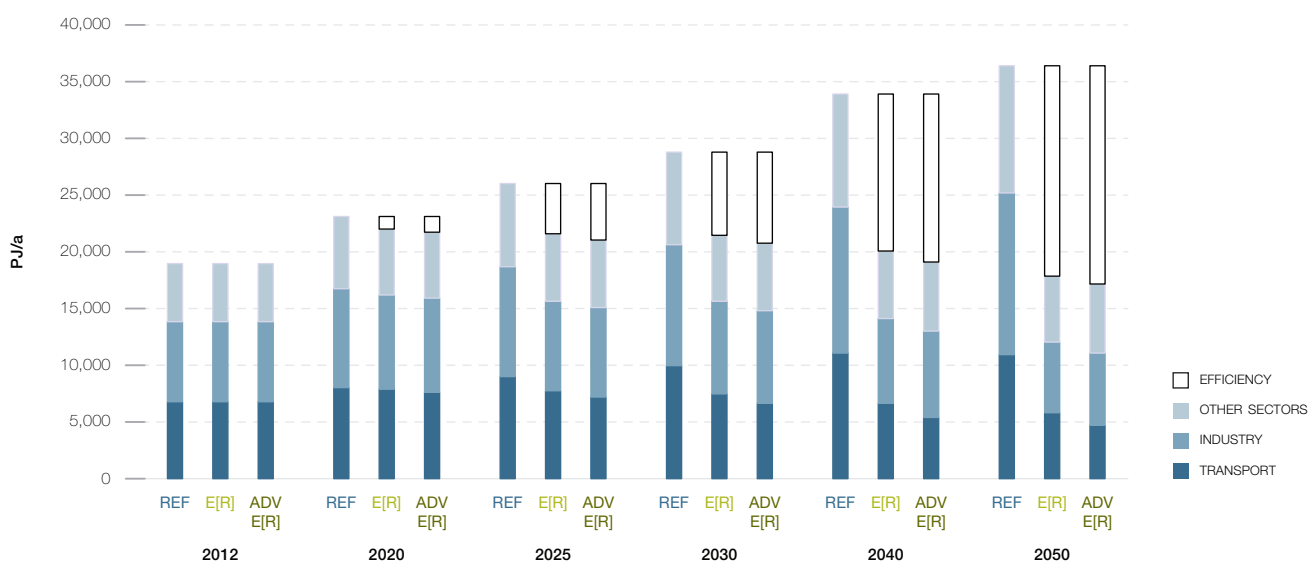
Combining the projections on population development, GDP growth and energy intensity results in future development pathways for Latin America's final energy demand. These are shown in Figure 6.3.1 for the Reference and Energy [R]evolution scenarios. Under the Reference scenario, total final energy demand increases by 91% from the current 19,000 PJ/a to 36,300 PJ/a in 2050. In the basic Energy [R]evolution scenario, final energy demand decreases by 6% compared to current consumption and is expected to reach 17,900 PJ/a by 2050. The Advanced scenario results in some additional reductions due to a higher share of electric cars.

Under both Energy [R]evolution scenarios, due to economic growth, increasing living standards and electrification of the transport sector, overall electricity demand is expected to increase despite efficiency gains in all sectors (see Figure 6.3.2). Total electricity demand will rise from about 990 TWh/a to 2,230 TWh/a by 2050 in the basic Energy [R]evolution scenario. Compared to the Reference scenario, efficiency measures in the industry, residential and service sectors avoid the generation of about 840 TWh/a.

This reduction can be achieved in particular by introducing highly efficient electronic devices using the best available technology in all demand sectors. The transformation to a carbon free energy system in the Advanced scenario will further increase the electricity demand in 2050 up to 2,500 TWh/a. Electricity will become the major renewable 'primary' energy, not only for direct use for various purposes but also for the generation of synthetic fuels for fossil fuels substitution. Around 600 TWh are used in 2050 for electric vehicles and rail transport in 2050 in the Advanced scenario, around 430 TWh for hydrogen and 90 TWh for synthetic liquid fuel generation for the transport sector (excluding bunkers).

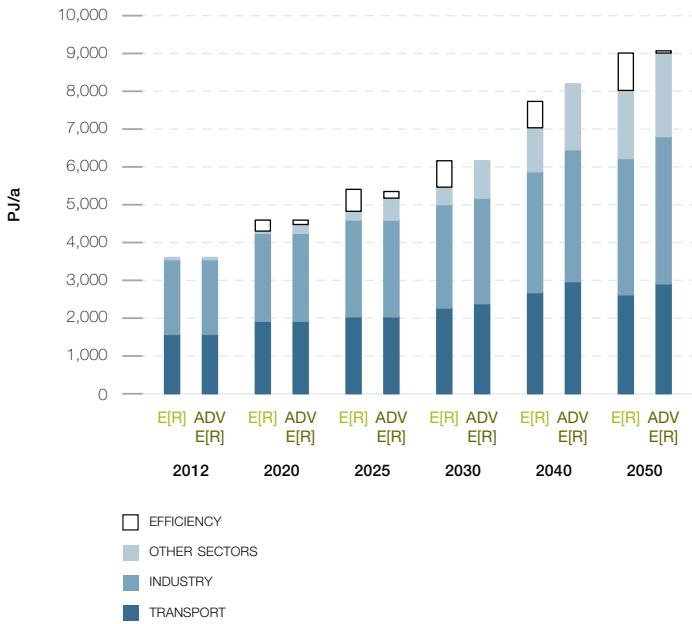
Efficiency gains in the heating sector are even larger than in the electricity sector. Under the Energy [R]evolution scenarios, consumption equivalent to about 6,900 PJ/a is avoided through efficiency gains by 2050 compared to the Reference scenario. As a result of energy-related renovation of the existing stock of residential buildings, the introduction of low energy standards and 'passive climatisation' for new buildings, as well as highly efficient air conditioning systems, enjoyment of the same comfort and energy services will be accompanied by much lower future energy demand.

**FIGURE 6.3.1 | LATIN AMERICA: PROJECTION OF TOTAL FINAL ENERGY DEMAND BY SECTOR – REFERENCE, ENERGY [R]EVOLUTION, ADVANCED ENERGY [R]EVOLUTION SCENARIOS** WITHOUT NON-ENERGY USE AND HEAT FROM CHP AUTOPRODUCERS

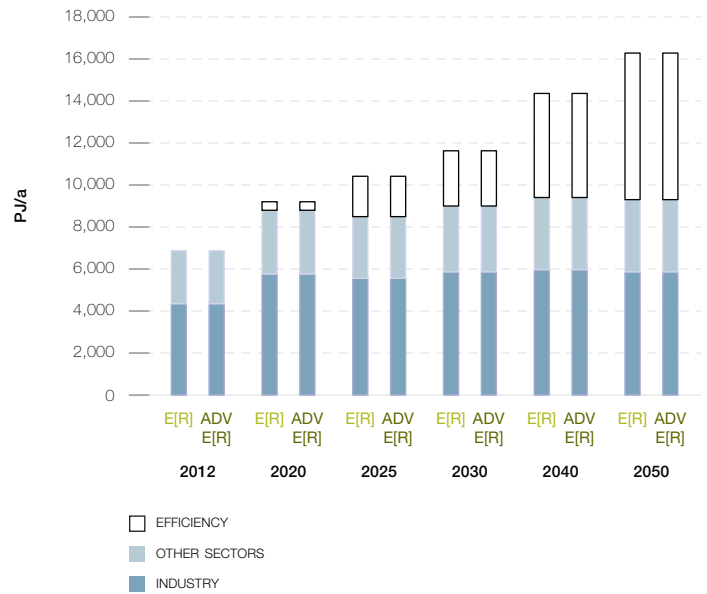




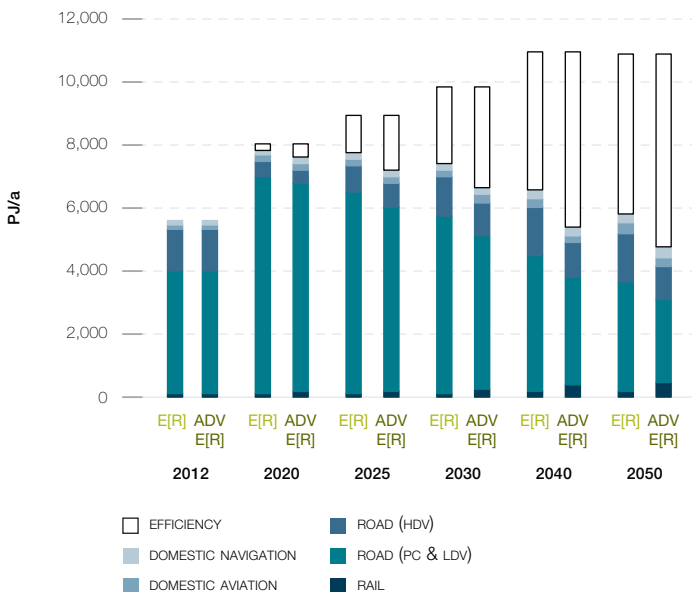
**FIGURE 6.3.2 | LATIN AMERICA: DEVELOPMENT OF ELECTRICITY DEMAND BY SECTOR IN THE ENERGY [R]EVOLUTION SCENARIOS**



**FIGURE 6.3.4 | LATIN AMERICA: DEVELOPMENT OF FINAL ENERGY DEMAND FOR HEAT BY SECTOR IN THE ENERGY [R]EVOLUTION SCENARIOS**



**FIGURE 6.3.3 | LATIN AMERICA: DEVELOPMENT OF THE FINAL ENERGY DEMAND FOR TRANSPORT BY SECTOR IN THE ENERGY [R]EVOLUTION SCENARIOS**



### 6.3.2 ELECTRICITY GENERATION

The development of the electricity supply sector is characterised by a dynamically growing renewable energy market and an increasing share of renewable electricity. This trend will more than compensate for the phasing out of nuclear power production in the Energy [R]evolution scenarios, continuously reducing the number of fossil fuel-fired power plants as well. By 2050, 94% of the electricity produced in Latin America will come from renewable energy sources in the basic Energy [R]evolution scenario. ‘New’ renewables – mainly wind, PV, CSP and geothermal energy – will contribute 50% to the total electricity generation. Already by 2020 the share of renewable electricity production will be 71% and 84% by 2030. The installed capacity of renewables will reach about 440 GW in 2030 and 930 GW by 2050.

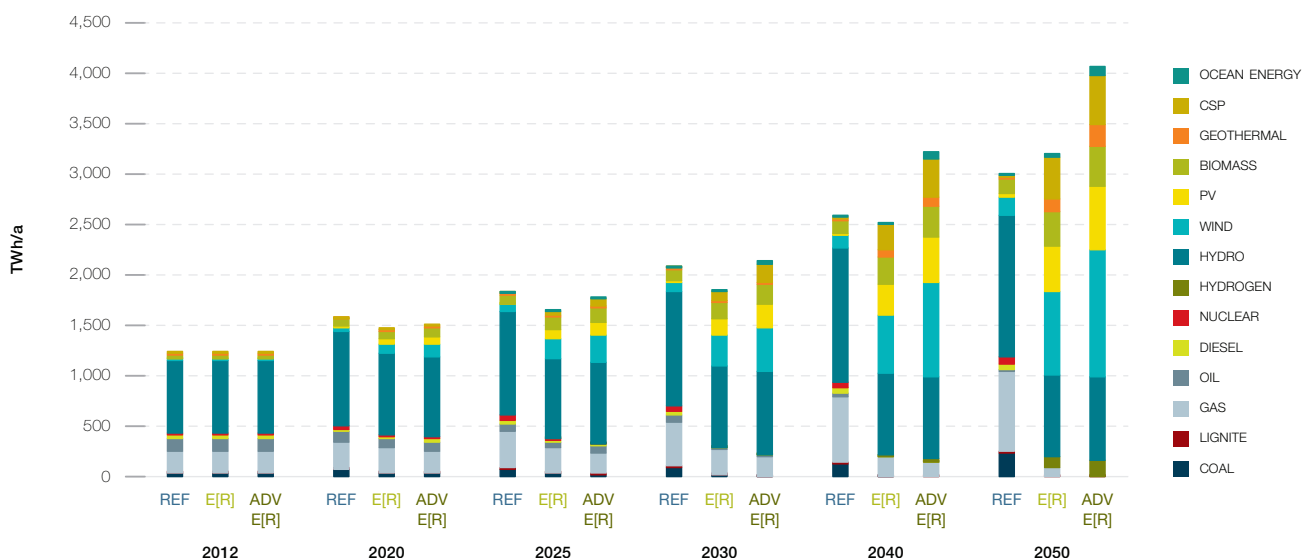
A 100% electricity supply from renewable energy resources in the Advanced scenario leads to around 1,230 GW installed generation capacity in 2050.

Table 6.3.1 shows the comparative evolution of the different renewable technologies in Latin America over time. Until 2040 hydro will remain the main renewable power source. By 2020 wind and PV overtake biomass, currently the second largest contributor to the growing renewable market. After 2020, the continuing growth of wind and PV will be complemented by electricity from solar thermal, geothermal and ocean energy. The Energy [R]evolution scenarios will lead to a high share of fluctuating power generation sources (PV, wind and ocean) of already 25% to 33% by 2030 and 41% to 49% by 2050. Therefore, smart grids, demand side management (DSM), energy storage capacities and other options need to be expanded in order to increase the flexibility of the power system for grid integration, load balancing and a secure supply of electricity.

**TABLE 6.3.1 | LATIN AMERICA: PROJECTION OF RENEWABLE ELECTRICITY GENERATION CAPACITY UNDER THE REFERENCE AND THE ENERGY [R]EVOLUTION SCENARIOS** IN GW

		2012	2020	2030	2040	2050
HYDRO	REF	148	192	242	285	304
	E[R]	148	164	166	168	169
	ADV	148	164	167	168	169
BIOMASS	REF	14	18	22	26	29
	E[R]	14	23	42	71	102
	ADV	14	23	45	73	105
WIND	REF	4	16	31	40	51
	E[R]	4	34	92	162	225
	ADV	4	41	128	260	344
GEOTHERMAL	REF	1	1	2	3	4
	E[R]	1	2	4	10	18
	ADV	1	2	4	15	32
PV	REF	0	4	11	17	26
	E[R]	0	35	111	227	322
	ADV	0	51	170	323	461
CSP	REF	0	0	1	3	5
	E[R]	0	1	23	63	80
	ADV	0	6	45	93	94
OCEAN	REF	0	0	0	0	0
	E[R]	0	0	1	6	10
	ADV	0	0	10	17	25
TOTAL	REF	166	231	309	374	418
	E[R]	166	259	438	706	926
	ADV	166	286	569	950	1,230

**FIGURE 6.3.5 | LATIN AMERICA: DEVELOPMENT OF ELECTRICITY GENERATION STRUCTURE – REFERENCE, ENERGY [R]EVOLUTION, ADVANCED ENERGY [R]EVOLUTION SCENARIOS**



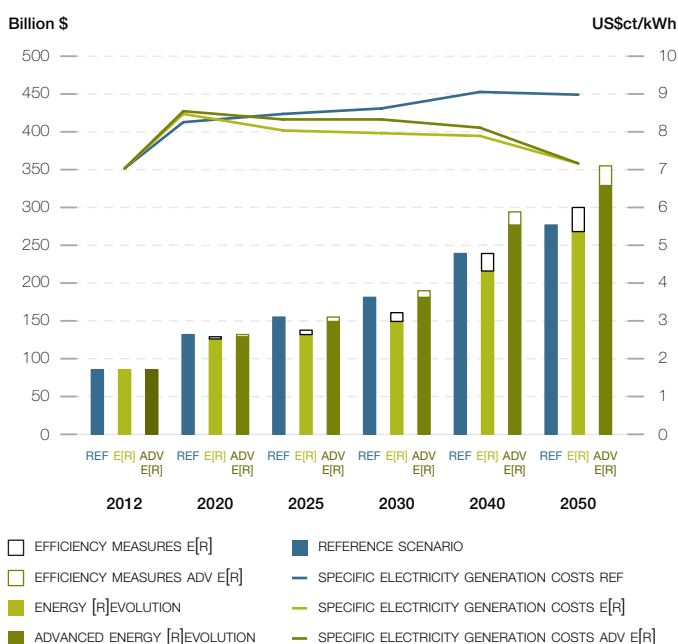
### 6.3.3 FUTURE COSTS OF ELECTRICITY GENERATION

Figure 6.3.6 shows that the introduction of renewable technologies under both Energy [R]evolution scenarios increases the future costs of electricity generation compared to the Reference scenario before 2030. This difference in full cost of generation will be less than 0.2 US\$ct/kWh in the basic Energy [R]evolution scenario and slightly more than 0.2 US\$ct/kWh in the Advanced scenario, without taking into account integration costs for storage or other load-balancing measures. Because of increasing prices for conventional fuels, electricity generation costs will become economically favourable starting in 2030 under the Energy [R]evolution scenarios. By 2050, the cost will be 1.8 US\$ct/kWh below those in the Reference case.

Under the Reference scenario, on the other hand, growth in demand and increasing fossil fuel prices result in total electricity supply costs rising from today's US\$ 87 billion per year to more than US\$ 279 billion in 2050, compared to US\$ 270 billion in the basic and US\$ 331 billion in the Advanced Energy [R]evolution scenario. Figure 6.3.6 shows that both Energy [R]evolution scenarios not only comply with Latin America's CO<sub>2</sub> reduction targets, but also help stabilise energy costs and relieve the economic pressure on society.

Increasing energy efficiency and shifting energy supply to renewables lead to long term costs for electricity supply that are 3% lower in the basic Energy [R]evolution scenario than in the Reference scenario despite a 7% increase in electricity production. The Advanced scenario with 100% renewable power and an increase in power generation of 36% results in supply costs 19% higher than the Reference case.

**FIGURE 6.3.6 | LATIN AMERICA: DEVELOPMENT OF TOTAL ELECTRICITY SUPPLY COSTS & OF SPECIFIC ELECTRICITY GENERATION COSTS IN THE SCENARIOS**



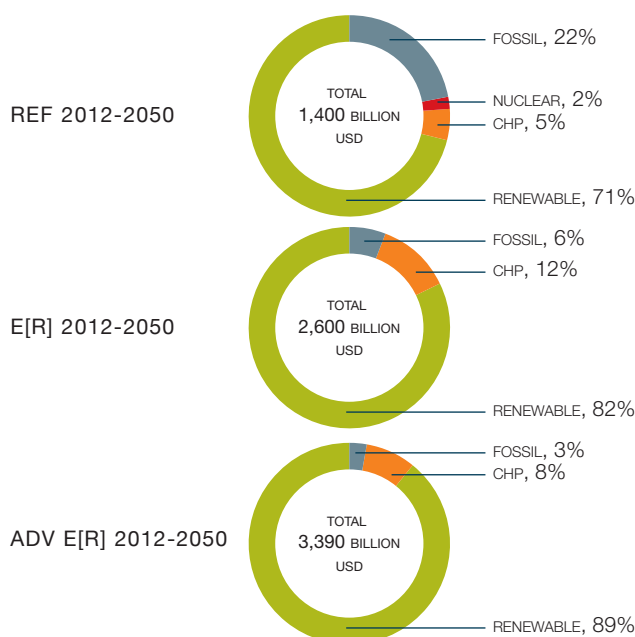
### 6.3.4 FUTURE INVESTMENTS IN THE POWER SECTOR

Around US\$ 2,600 billion is required in investment for the Energy [R]evolution scenario to become reality (including investments for replacement after the economic lifetime of the plants) - approximately US\$ 67 billion per year, US\$ 1,200 billion more than in the Reference scenario (US\$ 1,400 billion). Investments for the Advanced scenario sum up to US\$ 3,390 billion until 2050, on average US\$ 87 billion per year. Under the Reference scenario, the levels of investment in conventional power plants add up to almost 24% while approximately 76% would be invested in renewable energies and cogeneration until 2050.

Under the Energy [R]evolution scenarios, however, Latin America would shift almost 94%/97% of the entire investment towards renewables and cogeneration, respectively. By 2030, the fossil fuel share of power sector investment would be focused mainly on gas power plants.

Because renewable energy has no fuel costs, the fuel cost savings in the basic Energy [R]evolution scenario reach a total of US\$ 1,880 billion up to 2050, US\$ 48 billion per year. The total fuel cost savings therefore would cover 160% of the total additional investments compared to the Reference scenario. Fuel cost savings in the Advanced scenario are even higher and add up to US\$ 2,040 billion, or US\$ 52 billion per year. Renewable energy sources would then go on to produce electricity without any further fuel costs beyond 2050, while costs for coal and gas will continue to be a burden on national economies.

**FIGURE 6.3.7 | LATIN AMERICA: INVESTMENT SHARES - REFERENCE VERSUS ENERGY [R]EVOLUTION SCENARIOS**



### 6.3.5 ENERGY SUPPLY FOR HEATING

Today, renewables meet around 39% of Latin America’s energy demand for heating, the main contribution coming from the use of biomass. Dedicated support instruments are required to ensure a dynamic development in particular for renewable technologies for buildings and renewable process heat production. In the basic Energy [R]evolution scenario, renewables already provide 63% of Latin America’s total heat demand in 2030 and 93% in 2050.

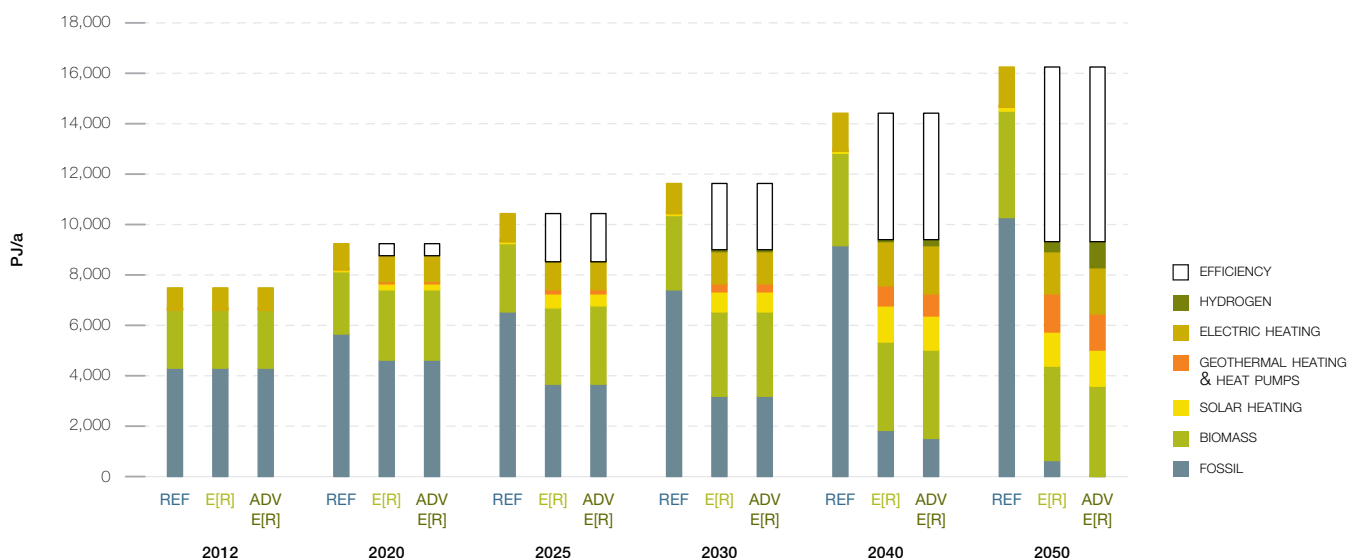
- Energy efficiency measures help to reduce the currently growing energy demand for heating by 43 % in 2050 (relative to the Reference scenario), in spite of improving living standards and economic growth.
- In the industry sector solar collectors, geothermal energy (incl. heat pumps) as well as electricity and hydrogen from renewable sources are increasingly substituting for fossil fuel-fired systems.
- A shift from coal and oil to natural gas in the remaining conventional applications leads to a further reduction of CO<sub>2</sub> emissions.

Table 6.3.2 shows the development of different renewable technologies for heating in Latin America over time. Although biomass remains the main contributor, its market share is decreasing and with it inefficient traditional biomass. After 2030, the continuing growth of solar collectors and a growing share of geothermal and environmental heat as well as heat from renewable hydrogen will further reduce the dependence on fossil fuels. The Advanced scenario results in a complete substitution of the remaining gas consumption by hydrogen generated from renewable electricity.

**TABLE 6.3.2 | LATIN AMERICA: PROJECTION OF RENEWABLE HEAT SUPPLY UNDER THE REFERENCE AND BOTH ENERGY [R]EVOLUTION SCENARIOS** IN PJ/a

		2012	2020	2030	2040	2050
BIOMASS	REF	2,314	2,726	2,950	3,616	4,213
	E[R]	2,314	3,076	3,359	3,557	3,734
	ADV	2,314	3,079	3,365	3,479	3,608
SOLAR HEATING	REF	22	74	94	149	220
	E[R]	22	515	828	1,380	1,395
	ADV	22	515	828	1,380	1,395
GEOTHERMAL HEAT AND HEAT PUMPS	REF	0	0	0	0	0
	E[R]	0	177	296	859	1,474
	ADV	0	178	296	872	1,487
HYDROGEN	REF	0	0	0	0	0
	E[R]	0	1	13	58	359
	ADV	0	1	7	230	1,045
TOTAL	REF	2,336	2,800	3,044	3,765	4,433
	E[R]	2,336	3,769	4,497	5,854	6,963
	ADV	2,336	3,773	4,496	5,961	7,533

**FIGURE 6.3.8 | LATIN AMERICA: PROJECTION OF HEAT SUPPLY BY ENERGY CARRIER – REFERENCE, ENERGY [R]EVOLUTION, ADVANCED ENERGY [R]EVOLUTION SCENARIOS**



### 6.3.6 FUTURE INVESTMENTS IN THE HEATING SECTOR

Also in the heating sector the Energy [R]evolution scenarios would require a major revision of current investment strategies in heating technologies. In particular, solar thermal, geothermal and heat pump technologies need an enormous increase in installations if these potentials are to be tapped for the heating sector. The use of biomass for heating purposes - often traditional biomass today - will be substantially reduced in the Energy [R]evolution scenarios and replaced by more efficient and sustainable renewable heating technologies.

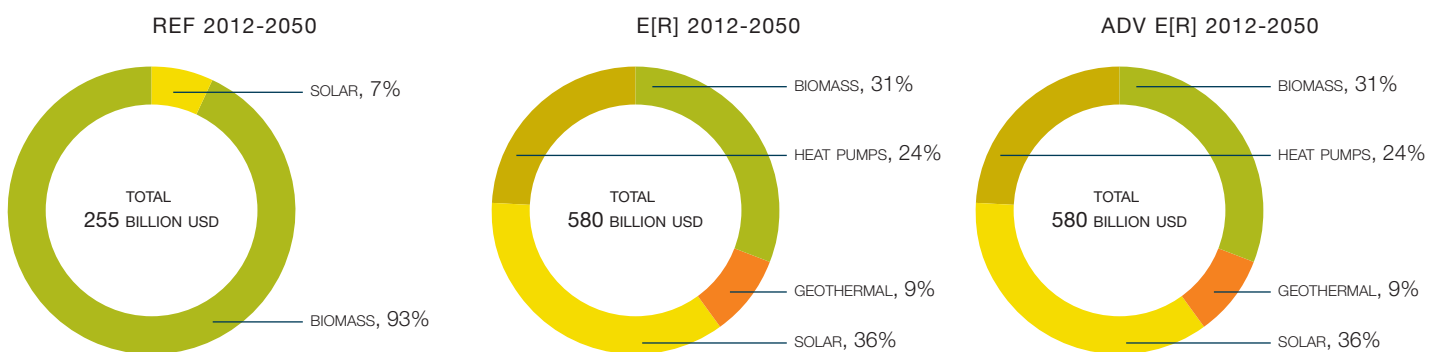
Renewable heating technologies are extremely variable, from low tech biomass stoves and unglazed solar collectors to very sophisticated enhanced geothermal and solar systems. Thus, it can only be roughly estimated that the Energy [R]evolution scenario in total requires around US\$ 580 billion to be invested in renewable heating technologies up to 2050 (including investments for replacement after the economic lifetime of the plants) - approximately US\$ 15 billion per year. The Advanced scenario assumes an equally ambitious expansion of renewable technologies resulting in an average investment of around US\$ 15 billion per year, while the main strategy in the scenario is the substitution of the remaining natural gas amounts with electricity, hydrogen or other synthetic fuels.

**TABLE 6.3.3 | LATIN AMERICA: INSTALLED CAPACITIES FOR RENEWABLE HEAT GENERATION UNDER THE SCENARIOS IN GW**

		2012	2020	2030	2040	2050
BIOMASS	REF	610	626	694	761	779
	E[R]	610	720	741	600	462
	ADV	610	720	741	572	416
GEOTHERMAL	REF	0	0	0	0	0
	E[R]	0	1	6	17	22
	ADV	0	1	6	17	22
SOLAR HEATING	REF	5	13	23	37	55
	E[R]	5	75	205	340	342
	ADV	5	75	205	340	342
HEAT PUMPS	REF	0	0	0	0	0
	E[R]	0	10	21	43	65
	ADV	0	10	21	43	65
TOTAL*	REF	616	640	718	798	833
	E[R]	616	805	972	1,000	892
	ADV	616	805	972	973	845

\* Excluding direct electric heating.

**FIGURE 6.3.9 | LATIN AMERICA: DEVELOPMENT OF INVESTMENTS FOR RENEWABLE HEAT GENERATION TECHNOLOGIES – REFERENCE, ENERGY [R]EVOLUTION, ADVANCED ENERGY [R]EVOLUTION SCENARIOS**



### 6.3.7 FUTURE EMPLOYMENT IN THE ENERGY SECTOR

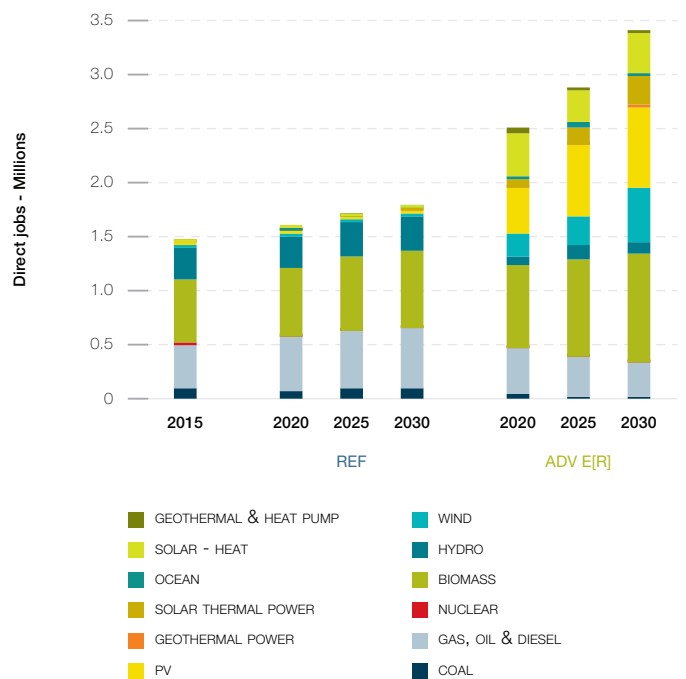
The Advanced Energy [R]evolution scenario results in more energy sector jobs in Latin America at every stage of the projection.

- There are 2.5 million energy sector jobs in the Advanced Energy [R]evolution in 2020, and 1.6 million in the Reference scenario.
- In 2025, there are 2.9 million jobs in the Advanced Energy [R]evolution scenario, and 1.7 million in the Reference scenario.
- In 2030, there are 3.4 million jobs in the Advanced Energy [R]evolution scenario and 1.8 million in the Reference scenario.

Figure 6.3.10 shows the change in job numbers under both scenarios for each technology between 2015 and 2030. Jobs in the Reference scenario increase by 21% by 2030. Biomass has the largest share in this scenario, followed by gas and then hydro.

Exceptionally strong growth in renewable energy leads to an increase of 70% in energy sector jobs in the Advanced Energy [R]evolution scenario by 2020, offsetting loses in the fossil fuel sectors. Jobs continue to rise to 132% above 2015 levels by 2030. Renewable energy accounts for 90% of energy sector jobs in 2030, with biomass having the largest share (29%), followed by solar PV and wind.

**FIGURE 6.3.10 | LATIN AMERICA: EMPLOYMENT IN THE ENERGY SECTOR UNDER THE REFERENCE AND ADVANCED ENERGY [R]EVOLUTION SCENARIO**



**TABLE 6.3.4 | LATIN AMERICA: TOTAL EMPLOYMENT IN THE ENERGY SECTOR IN THOUSAND JOBS**

	2015	2020	REFERENCE		ADVANCED ENERGY [R]EVOLUTION		
			2025	2030	2020	2025	2030
COAL	88	81	89	109	34	27	13
GAS, OIL & DIESEL	418	483	530	544	422	367	312
NUCLEAR	9	10	10	11	4	5	7
RENEWABLES	958	1,024	1,098	1,120	2,050	2,485	3,092
<b>TOTAL JOBS</b>	<b>1,472</b>	<b>1,597</b>	<b>1,727</b>	<b>1,784</b>	<b>2,510</b>	<b>2,884</b>	<b>3,423</b>
CONSTRUCTION AND INSTALLATION	246	232	226	198	804	922	1,071
MANUFACTURING	106	103	104	95	348	447	662
OPERATIONS AND MAINTENANCE	284	319	351	372	434	572	717
FUEL SUPPLY (DOMESTIC)	790	890	987	1,057	891.0	920	962
COAL AND GAS EXPORT	46	54	59	63	33	22	11
<b>TOTAL JOBS</b>	<b>1,472</b>	<b>1,597</b>	<b>1,727</b>	<b>1,784</b>	<b>2,510</b>	<b>2,884</b>	<b>3,423</b>

### 6.3.8 TRANSPORT

A key target in Latin America is to introduce incentives for people to drive smaller cars and buy new, more efficient vehicle concepts. In addition, it is vital to shift transport use to efficient modes like rail, light rail and buses, especially in the expanding large metropolitan areas. Along with rising prices for fossil fuels, these changes reduce the further growth in car sales projected under the Reference scenario. Due to population increase, GDP growth and higher living standards, energy demand from the transport sector is expected to increase in the Reference scenario by around 61% to 11,030 PJ/a in 2050. In the basic Energy [R]evolution scenario, efficiency measures and modal shifts will save 47% (5,150 PJ/a) in 2050 compared to the Reference scenario.

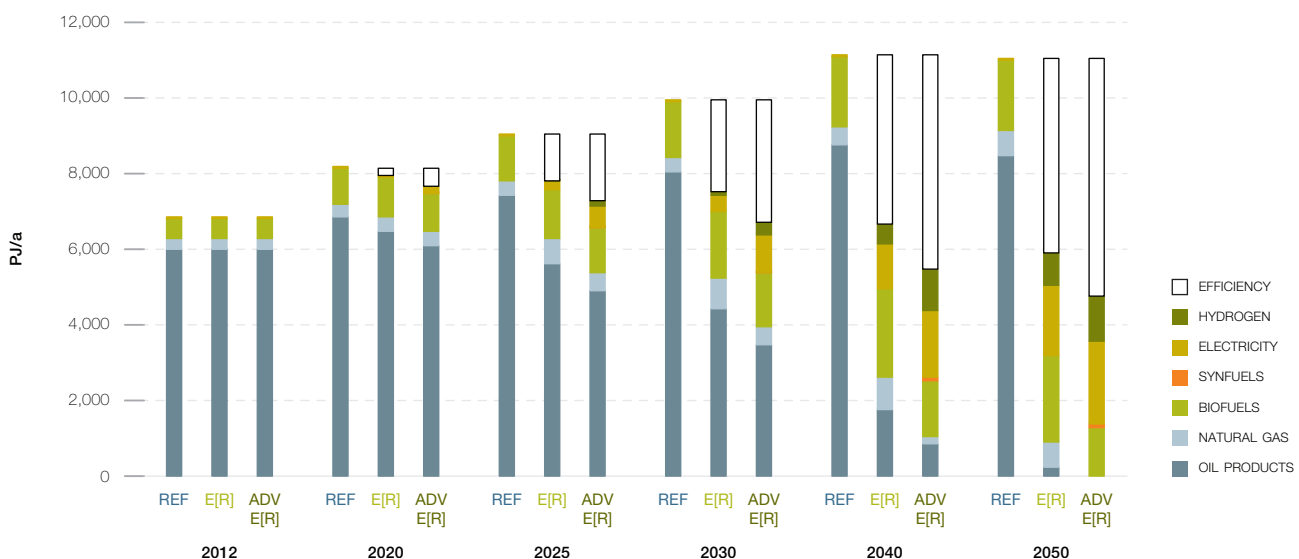
Additional modal shifts and technology switches lead to even higher energy savings in the Advanced scenario of 57% (6,290 PJ/a) in 2050 compared to the Reference scenario. Highly efficient propulsion technology with hybrid, plug-in hybrid and battery-electric power trains will bring about large efficiency gains. By 2030, electricity will provide 6% of the transport sector's total energy demand in the Energy [R]evolution, while in 2050 the share will be 31% (46% in the Advanced scenario). Hydrogen and other synthetic fuels generated using renewable electricity are complementary options to further increase the renewable share in the transport sector. In 2050, up to 1,180 PJ/a of hydrogen is used in the transport sector for the Advanced Energy [R]evolution scenario.

**TABLE 6.3.5 | LATIN AMERICA: PROJECTION OF TRANSPORT ENERGY DEMAND BY MODE IN THE REFERENCE AND THE ENERGY [R]EVOLUTION SCENARIOS IN PJ/a**

		2012	2020	2030	2040	2050
RAIL	REF	93	196	225	284	343
	E[R]	93	143	146	173	170
	ADV	93	163	257	415	442
ROAD	REF	5,216	8,286	9,093	10,099	9,856
	E[R]	5,216	7,326	6,836	5,886	5,053
	ADV	5,216	7,052	5,941	4,489	3,742
DOMESTIC AVIATION	REF	164	288	324	386	418
	E[R]	164	229	241	278	301
	ADV	164	219	225	245	253
DOMESTIC NAVIGATION	REF	108	168	186	223	259
	E[R]	108	164	205	258	307
	ADV	108	164	205	258	307
TOTAL	REF	5,580	8,938	9,828	10,991	10,876
	E[R]	5,580	7,862	7,428	6,594	5,831
	ADV	5,580	7,599	6,627	5,407	4,744

6

**FIGURE 6.3.11 | LATIN AMERICA: FINAL ENERGY CONSUMPTION IN TRANSPORT UNDER THE SCENARIOS**



### 6.3.10 DEVELOPMENT OF CO<sub>2</sub> EMISSIONS

Whilst Latin America's emissions of CO<sub>2</sub> will increase by 78% between 2012 and 2050 under the Reference scenario, under the Energy [R]evolution scenario they will decrease from 1,230 million tonnes in 2012 to 138 million tonnes in 2050. Annual per capita emissions will drop from 2.5 tonne to 0.2 tonne. In spite of the abstinence of nuclear power production and increasing power demand, CO<sub>2</sub> emissions will decrease in the electricity sector. In the long run efficiency gains and the increased use of renewable electricity in vehicles strongly reduce emissions in the transport sector as well.

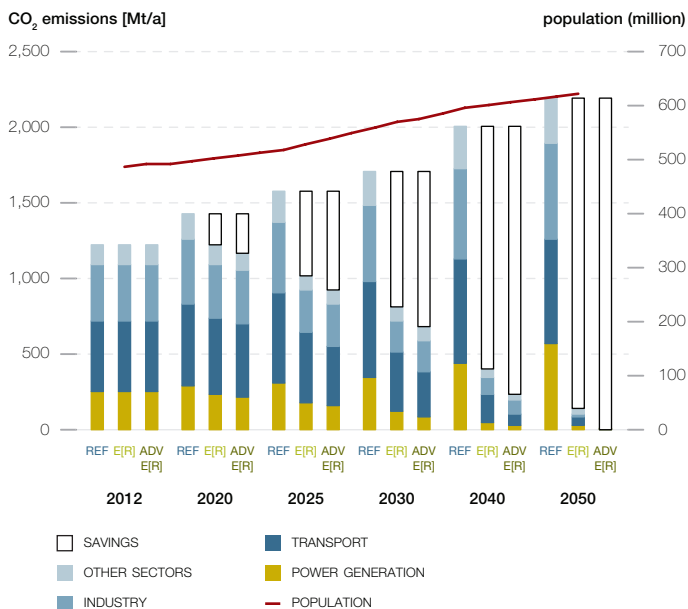
With a 39% share of CO<sub>2</sub>, the Transport sector will be the largest source of emissions in 2050 in the basic Energy [R]evolution scenario. By 2050, Latin America's CO<sub>2</sub> emissions are around 76% below 1990 levels in the Energy [R]evolution scenario while energy consumption is fully decarbonised in the Advanced case.

### 6.3.11 PRIMARY ENERGY CONSUMPTION

Taking into account the assumptions discussed above, the resulting primary energy consumption under the Energy [R]evolution scenarios is shown in Figure 6.3.12. Under the basic Energy [R]evolution scenario, primary energy demand increases slightly from today's 27,120 PJ/a and starts to decrease after 2020 to again around 27,000 PJ/a in 2050. Compared to the Reference scenario, overall primary energy demand will be reduced by 44% in 2050 under the Energy [R]evolution scenario (Reference scenario: around 49,000 PJ in 2050). The Advanced scenario results due to additional conversion losses in a primary energy consumption of around 28,700 PJ in 2050.

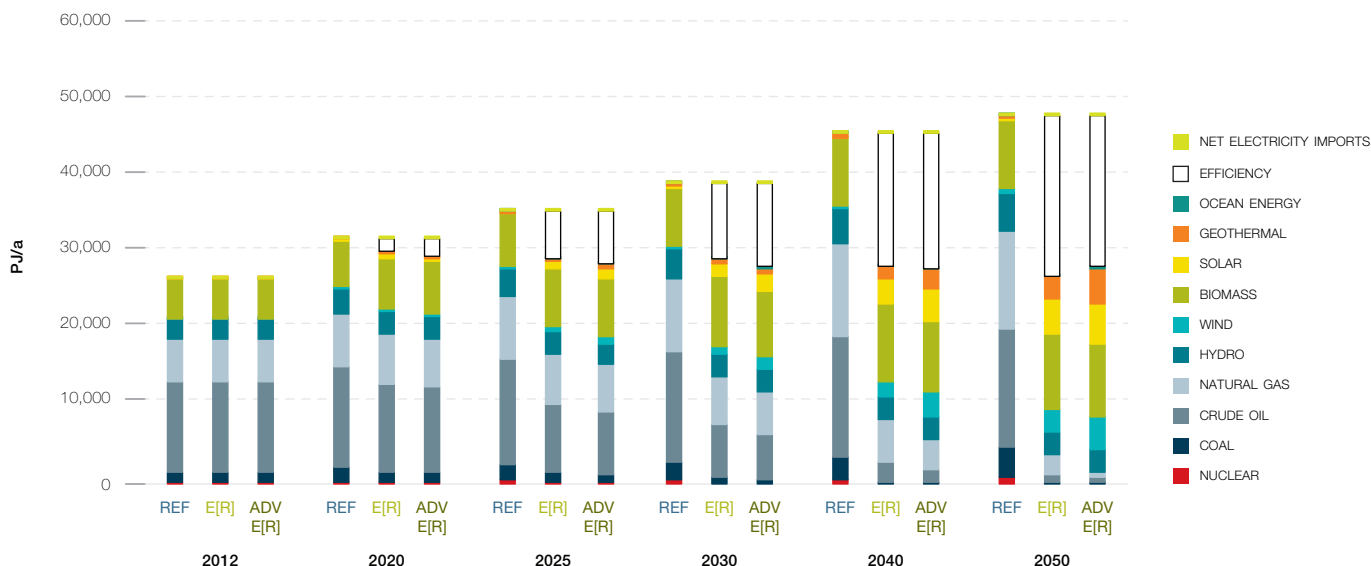
The Energy [R]evolution scenarios aim to phase out coal and oil as fast as technically and economically possible by

**FIGURE 6.3.13 | LATIN AMERICA: DEVELOPMENT OF CO<sub>2</sub> EMISSIONS BY SECTOR UNDER THE ENERGY [R]EVOLUTION SCENARIOS** 'SAVINGS' = REDUCTION COMPARED TO THE REFERENCE SCENARIO



expansion of renewable energies and a fast introduction of very efficient vehicle concepts in the transport sector to replace oil based combustion engines. This leads to an overall renewable primary energy share of 52% in 2030 and 86% in 2050 in the basic Energy [R]evolution and of more than 95% in 2050 in the Advanced case (incl. non-energy consumption). In contrast to the Reference scenario, no new nuclear power plants will be built in Latin America in the Energy [R]evolution scenarios.

**FIGURE 6.3.12 | LATIN AMERICA: PROJECTION OF TOTAL PRIMARY ENERGY DEMAND (PED) BY ENERGY CARRIER INCLUDING ELECTRICITY** INCLUDING ELECTRICITY IMPORT BALANCE – REFERENCE, ENERGY [R]EVOLUTION, ADVANCED ENERGY [R]EVOLUTION SCENARIOS





**TABLE 6.3.6 | LATIN AMERICA: ACCUMULATED INVESTMENT COSTS FOR ELECTRICITY GENERATION AND FUEL COST SAVINGS UNDER THE ENERGY [R]EVOLUTION SCENARIO COMPARED TO THE REFERENCE SCENARIO**

ACCUMULATED INVESTMENT COSTS DIFFERENCE REF MINUS E[R]	UNIT	2012-2020	2021-2030	2031-2040	2041-2050	2012-2050	2012 - 2050 AVERAGE PER YEAR
CONVENTIONAL (FOSSIL + NUCLEAR)	BILLION \$	17.9	40.5	54.4	80.2	193.0	4.9
RENEWABLES (INCL. CHP)	BILLION \$	-44.2	-251.6	-556.3	-548.3	-1,400.5	-35.9
TOTAL	BILLION \$	-26.3	-211.2	-501.9	-468.1	-1,207.6	-31.0
<b>ACCUMULATED FUEL COST SAVINGS</b>							
SAVINGS CUMULATIVE E[R] VERSUS REF							
FUEL OIL	BILLION \$	7.5	56.3	88.9	58.9	211.7	5.4
GAS	BILLION \$	4.8	168.2	474.1	810.1	1,457.2	37.4
HARD COAL	BILLION \$	7.2	25.9	49.0	88.1	170.2	4.4
LIGNITE	BILLION \$	0.1	0.8	1.8	2.3	5.0	0.1
NUCLEAR ENERGY	BILLION \$	0.7	5.2	10.2	15.0	31.1	0.8
TOTAL	BILLION \$	20.3	256.5	624.0	974.4	1,875.2	48.1

**TABLE 6.3.7 | LATIN AMERICA: ACCUMULATED INVESTMENT COSTS FOR RENEWABLE HEAT GENERATION UNDER THE ENERGY [R]EVOLUTION SCENARIO COMPARED TO THE REFERENCE SCENARIO**

ACCUMULATED INVESTMENT COSTS DIFFERENCE REF MINUS E[R]	UNIT	2012-2020	2021-2030	2031-2040	2041-2050	2012-2050	2012 - 2050 AVERAGE PER YEAR
RENEWABLES	BILLION \$	73.8	83.6	122.8	45.1	325.4	8.3

**TABLE 6.3.8 | LATIN AMERICA: ACCUMULATED INVESTMENT COSTS FOR ELECTRICITY GENERATION AND FUEL COST SAVINGS UNDER THE ADVANCED ENERGY [R]EVOLUTION SCENARIO COMPARED TO THE REFERENCE SCENARIO**

ACCUMULATED INVESTMENT COSTS DIFFERENCE REF MINUS ADVANCED E[R]	UNIT	2012-2020	2021-2030	2031-2040	2041-2050	2012-2050	2012 - 2050 AVERAGE PER YEAR
CONVENTIONAL (FOSSIL + NUCLEAR)	BILLION \$	21.5	50.0	59.0	113.0	243.4	6.2
RENEWABLES (INCL. CHP)	BILLION \$	-120.1	-536.1	-841.5	-743.3	-2,240.9	-57.5
TOTAL	BILLION \$	-98.6	-486.1	-782.5	-630.3	-1,997.5	-51.2
<b>ACCUMULATED FUEL COST SAVINGS</b>							
SAVINGS CUMULATIVE ADVANCED E[R] VERSUS REF							
FUEL OIL	BILLION \$	2.9	53.2	86.3	58.6	200.9	5.2
GAS	BILLION \$	18.3	214.4	526.5	868.4	1,627.7	41.7
HARD COAL	BILLION \$	7.6	29.5	51.7	88.3	177.0	4.5
LIGNITE	BILLION \$	0.1	0.8	1.8	2.3	5.0	0.1
NUCLEAR ENERGY	BILLION \$	0.7	5.2	10.2	15.0	31.1	0.8
TOTAL	BILLION \$	29.5	303.0	676.5	1,032.6	2,041.7	52.4

**TABLE 6.3.9 | LATIN AMERICA: ACCUMULATED INVESTMENT COSTS FOR RENEWABLE HEAT GENERATION UNDER THE ADVANCED ENERGY [R]EVOLUTION SCENARIO COMPARED TO THE REFERENCE SCENARIO**

ACCUMULATED INVESTMENT COSTS DIFFERENCE REF MINUS ADVANCED E[R]	UNIT	2012-2020	2021-2030	2031-2040	2041-2050	2012-2050	2012 - 2050 AVERAGE PER YEAR
RENEWABLES	BILLION \$	73.8	83.6	122.8	44.9	325.2	8.3

## 6.4 OECD EUROPE

### 6.4.1 FINAL ENERGY DEMAND BY SECTOR

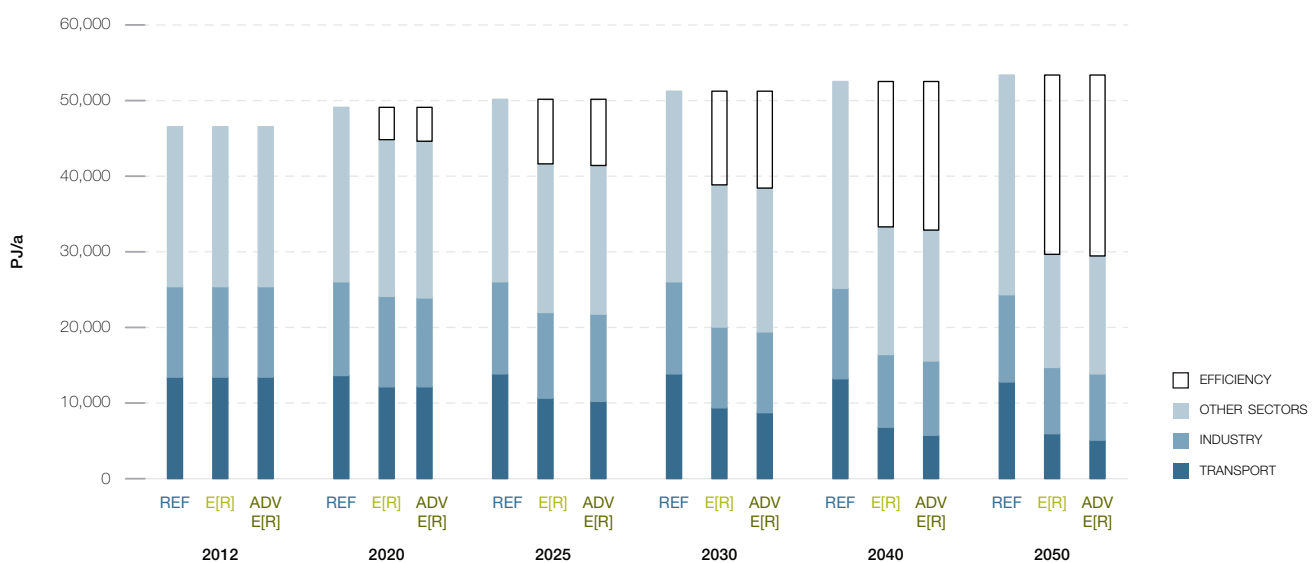
Combining the projections on population development, GDP growth and energy intensity results in future development pathways for OECD Europe's final energy demand. These are shown in Figure 6.4.1 for the Reference and Energy [R]evolution scenarios. Under the Reference scenario, total final energy demand increases by 15% from the current 46,600 PJ/a to 53,500 PJ/a in 2050. In the basic Energy [R]evolution scenario, final energy demand decreases by 36% compared to current consumption and is expected to reach 29,800 PJ/a by 2050. The Advanced scenario results in some additional reductions due to a higher share of electric cars.

Under both Energy [R]evolution scenarios, due to economic growth, increasing living standards and electrification of the transport sector, overall electricity demand is expected to increase despite efficiency gains in all sectors (see Figure 6.4.2). Total electricity demand will rise from about 3,070 TWh/a to 3,420 TWh/a by 2050 in the basic Energy [R]evolution scenario. Compared to the Reference scenario, efficiency measures in the industry, residential and service sectors avoid the generation of about 1,700 TWh/a.

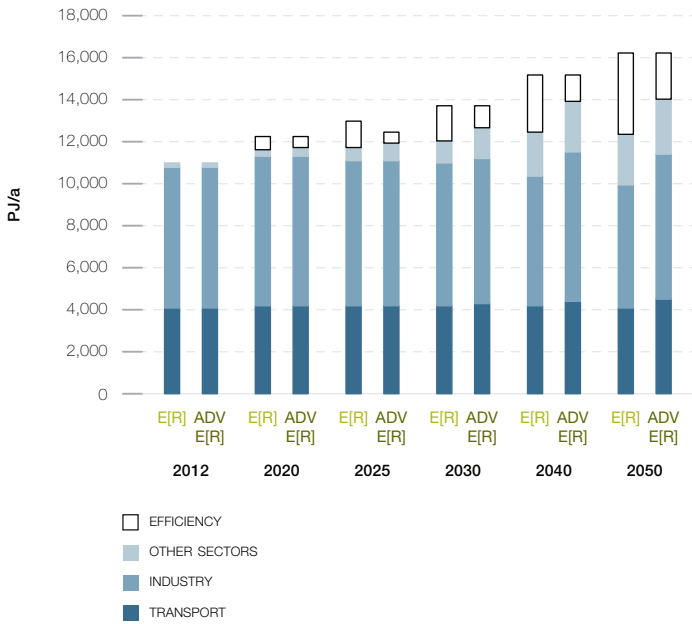
This reduction can be achieved in particular by introducing highly efficient electronic devices using the best available technology in all demand sectors. The transformation to a carbon free energy system in the Advanced scenario will further increase the electricity demand in 2050 up to 3,900 TWh/a. Electricity will become the major renewable 'primary' energy, not only for direct use for various purposes but also for the generation of synthetic fuels for fossil fuels substitution. Around 710 TWh are used in 2050 for electric vehicles and rail transport in 2050 in the Advanced scenario, around 580 TWh for hydrogen and 210 TWh for synthetic liquid fuel generation for the transport sector (excluding bunkers).

Efficiency gains in the heating sector are even larger than in the electricity sector. Under the Energy [R]evolution scenarios, consumption equivalent to about 8,800 PJ/a is avoided through efficiency gains by 2050 compared to the Reference scenario. As a result of energy-related renovation of the existing stock of residential buildings, the introduction of low energy standards and 'passive climatisation' for new buildings, as well as highly efficient air conditioning systems, enjoyment of the same comfort and energy services will be accompanied with much lower future energy demand.

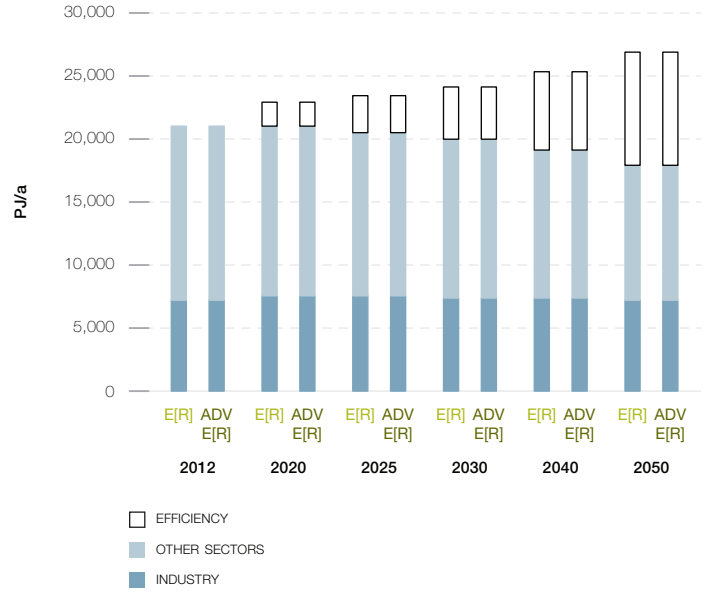
**FIGURE 6.4.1 | OECD EUROPE: PROJECTION OF TOTAL FINAL ENERGY DEMAND BY SECTOR – REFERENCE, ENERGY [R]EVOLUTION, ADVANCED ENERGY [R]EVOLUTION SCENARIOS** WITHOUT NON-ENERGY USE AND HEAT FROM CHP AUTOPRODUCERS



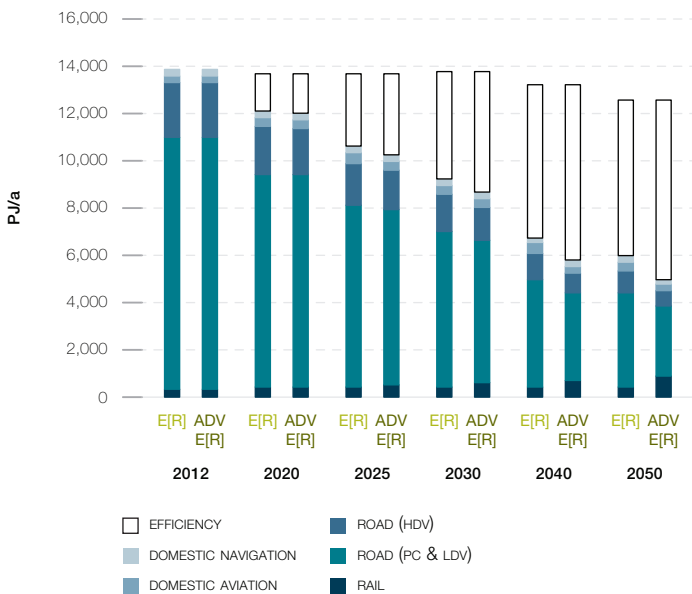
**FIGURE 6.4.2 | OECD EUROPE: DEVELOPMENT OF ELECTRICITY DEMAND BY SECTOR IN THE ENERGY [R]EVOLUTION SCENARIOS**



**FIGURE 6.4.4 | OECD EUROPE: DEVELOPMENT OF FINAL ENERGY DEMAND FOR HEAT BY SECTOR IN THE ENERGY [R]EVOLUTION SCENARIOS**



**FIGURE 6.4.3 | OECD EUROPE: DEVELOPMENT OF THE FINAL ENERGY DEMAND FOR TRANSPORT BY SECTOR IN THE ENERGY [R]EVOLUTION SCENARIOS**



### 6.4.2 ELECTRICITY GENERATION

The development of the electricity supply sector is characterised by a dynamically growing renewable energy market and an increasing share of renewable electricity. This trend will more than compensate for the phasing out of nuclear power production in the Energy [R]evolution scenarios, continuously reducing the number of fossil fuel-fired power plants as well. By 2050, 94% of the electricity produced in OECD Europe will come from renewable energy sources in the basic Energy [R]evolution scenario. ‘New’ renewables – mainly wind, PV, CSP and geothermal energy – will contribute 64% to the total electricity generation. Already by 2020 the share of renewable electricity production will be 42% and 66% by 2030. The installed capacity of renewables will reach about 1,050 GW in 2030 and 1,660 GW by 2050.

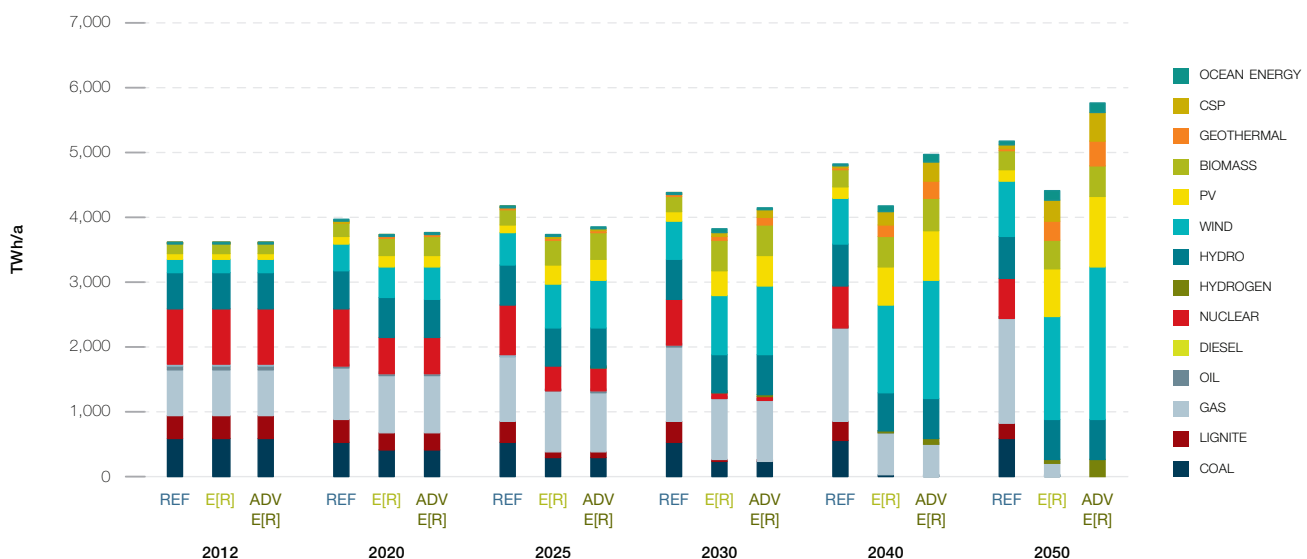
A 100% electricity supply from renewable energy resources in the Advanced scenario leads to around 2,280 GW installed generation capacity in 2050.

Table 6.4.1 shows the comparative evolution of the different renewable technologies in OECD Europe over time. Up to 2020 wind and PV will become the main contributors to the growing market share. After 2020, the continuing growth of wind and PV will be complemented by electricity from solar thermal, geothermal and ocean energy. The Energy [R]evolution scenarios will lead to a high share of fluctuating power generation sources (PV, wind and ocean) of already 35% to 38% by 2030 and 56% to 62% by 2050. Therefore, smart grids, demand side management (DSM), energy storage capacities and other options need to be expanded in order to increase the flexibility of the power system for grid integration, load balancing and a secure supply of electricity.

**TABLE 6.4.1 | OECD EUROPE: PROJECTION OF RENEWABLE ELECTRICITY GENERATION CAPACITY UNDER THE REFERENCE AND THE ENERGY [R]EVOLUTION SCENARIOS** IN GW

		2012	2020	2030	2040	2050
HYDRO	REF	202	214	225	232	240
	E[R]	202	214	216	219	223
	ADV	202	214	216	219	223
BIOMASS	REF	33	44	49	53	59
	E[R]	33	57	95	97	100
	ADV	33	61	100	105	108
WIND	REF	102	176	235	273	310
	E[R]	102	207	363	502	570
	ADV	102	210	416	672	831
GEOTHERMAL	REF	2	2	3	3	4
	E[R]	2	2	10	24	41
	ADV	2	2	14	34	52
PV	REF	68	113	132	145	156
	E[R]	68	168	341	513	620
	ADV	68	173	425	675	926
CSP	REF	2	3	5	9	14
	E[R]	2	4	16	43	65
	ADV	2	4	30	66	85
OCEAN	REF	0	0	2	11	19
	E[R]	0	1	12	34	45
	ADV	0	1	14	42	53
TOTAL	REF	409	553	651	727	803
	E[R]	409	653	1,053	1,432	1,664
	ADV	409	664	1,216	1,813	2,279

**FIGURE 6.4.5 | OECD EUROPE: DEVELOPMENT OF ELECTRICITY GENERATION STRUCTURE – REFERENCE, ENERGY [R]EVOLUTION, ADVANCED ENERGY [R]EVOLUTION SCENARIOS**



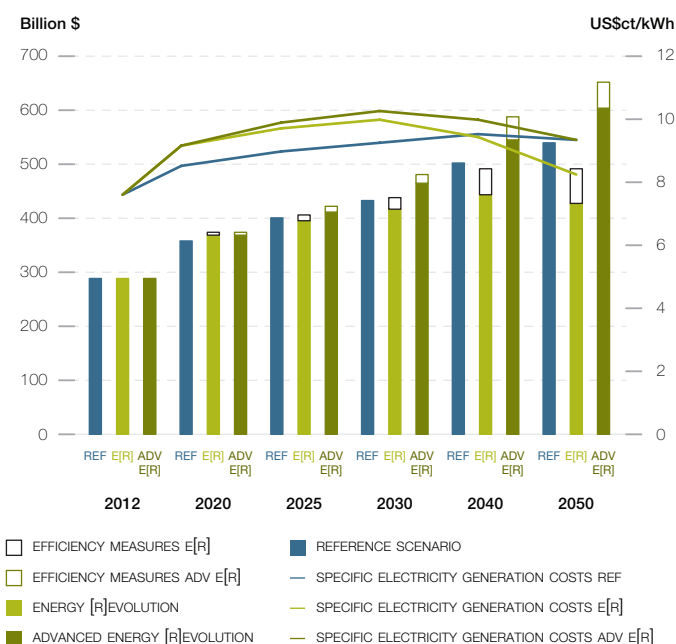
### 6.4.3 FUTURE COSTS OF ELECTRICITY GENERATION

Figure 6.4.6 shows that the introduction of renewable technologies under both Energy [R]evolution scenarios increases the future costs of electricity generation compared to the Reference scenario until 2030. This difference in full cost of generation will be less than 0.8 US\$/kWh in the basic Energy [R]evolution and about 1 US\$/kWh in the Advanced scenario, without taking into account integration costs for storage or other load-balancing measures. Because of increasing prices for conventional fuels, electricity generation costs will become economically favourable starting in 2040 under the Energy [R]evolution scenario. By 2050, the cost will be 1.1 US\$/kWh below and in the Advanced scenario equal to those in the Reference case.

Under the Reference scenario, on the other hand, growth in demand and increasing fossil fuel prices result in total electricity supply costs rising from today's US\$ 290 billion per year to more than US\$ 538 billion in 2050, compared to US\$ 427 billion in the basic and US\$ 601 billion in the Advanced Energy [R]evolution scenario. Figure 6.4.6 shows that the Energy [R]evolution scenario not only complies with OECD Europe's CO<sub>2</sub> reduction targets, but also helps stabilise energy costs and relieve the economic pressure on society.

Increasing energy efficiency and shifting energy supply to renewables lead to long term costs for electricity supply that are more than 21% lower in the basic Energy [R]evolution scenario than in the Reference scenario. The Advanced scenario with 100% renewable power and an increase in power generation of 12% results in supply costs 12% higher than the Reference case.

**FIGURE 6.4.6 | OECD EUROPE: DEVELOPMENT OF TOTAL ELECTRICITY SUPPLY COSTS & OF SPECIFIC ELECTRICITY GENERATION COSTS IN THE SCENARIOS**



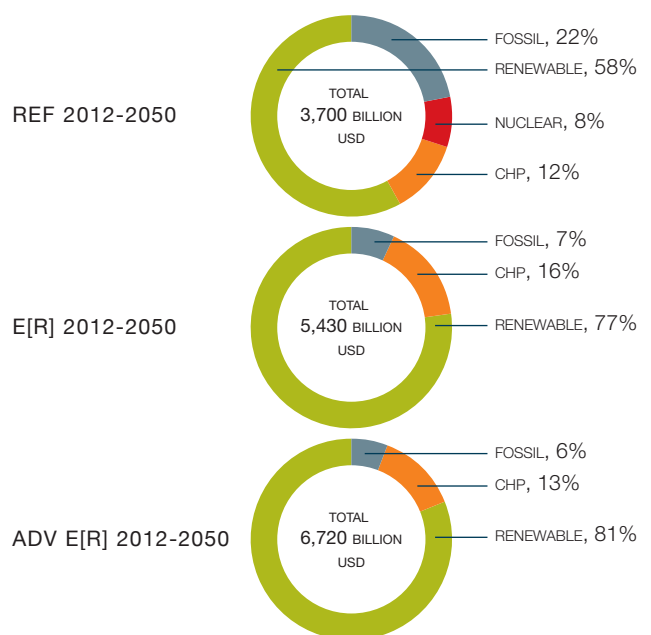
### 6.4.4 FUTURE INVESTMENTS IN THE POWER SECTOR

Around US\$ 5,430 billion is required in investment for the Energy [R]evolution scenario to become reality (including investments for replacement after the economic lifetime of the plants) - approximately US\$ 139 billion per year, US\$ 1,730 billion more than in the Reference scenario (US\$ 3,700 billion). Investments for the Advanced scenario add up to US\$ 6,720 billion until 2050, on average US\$ 172 billion per year, including high investments in additional power plants for the production of synthetic fuels. Under the Reference scenario, the levels of investment in conventional power plants add up to almost 30% while approximately 70% would be invested in renewable energies and cogeneration until 2050.

Under the Energy [R]evolution scenarios, however, OECD Europe would shift almost 93%/94% of the entire investment towards renewables and cogeneration, respectively. By 2030, the fossil fuel share of power sector investment would be focused mainly on gas power plants.

Because renewable energy has no fuel costs, the fuel cost savings in the basic Energy [R]evolution scenario reach a total of US\$ 3,610 billion up to 2050, US\$ 93 billion per year. The total fuel cost savings therefore would cover 210% of the total additional investments compared to the Reference scenario. Fuel cost savings in the Advanced scenario are even higher and add up to US\$ 3,780 billion, or US\$ 97 billion per year. Renewable energy sources would then go on to produce electricity without any further fuel costs beyond 2050, while costs for coal and gas will continue to be a burden on national economies.

**FIGURE 6.4.7 | OECD EUROPE: INVESTMENT SHARES - REFERENCE VERSUS ENERGY [R]EVOLUTION SCENARIOS**



### 6.4.5 ENERGY SUPPLY FOR HEATING

Today, renewables meet around 16% of OECD Europe’s energy demand for heating, the main contribution coming from the use of biomass. Dedicated support instruments are required to ensure a dynamic development in particular for renewable technologies for buildings and renewable process heat production. In the basic Energy [R]evolution scenario, renewables already provide 45% of OECD Europe’s total heat demand in 2030 and 86% in 2050.

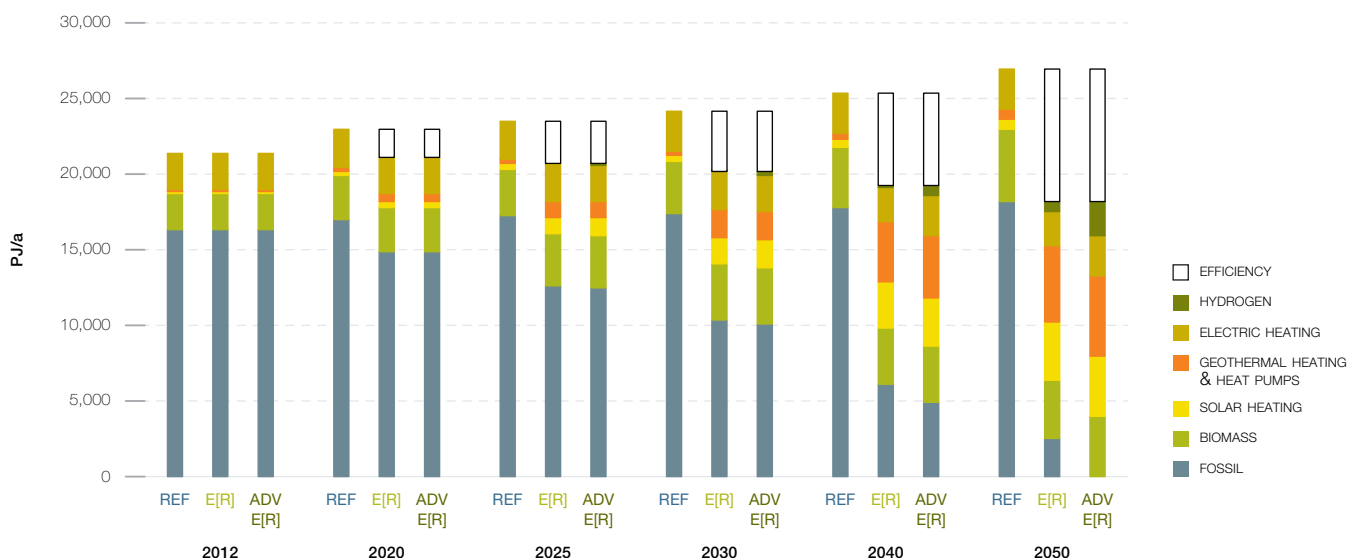
- Energy efficiency measures help to reduce the currently growing energy demand for heating by 33% in 2050 (relative to the Reference scenario), in spite of improving living standards and economic growth.
- In the industry sector solar collectors, geothermal energy (incl. heat pumps) as well as electricity and hydrogen from renewable sources are increasingly substituting for fossil fuel-fired systems.
- A shift from coal and oil to natural gas in the remaining conventional applications leads to a further reduction of CO<sub>2</sub> emissions.

Table 6.4.2 shows the development of different renewable technologies for heating in OECD Europe over time. Up to 2030 biomass remains the main contributor of the growing market share. After 2030, the continuing growth of solar collectors and a growing share of geothermal and environmental heat as well as heat from renewable hydrogen will further reduce the dependence on fossil fuels. The Advanced scenario results in a complete substitution of the remaining gas consumption by hydrogen generated from renewable electricity.

**TABLE 6.4.2 | OECD EUROPE: PROJECTION OF RENEWABLE HEAT SUPPLY UNDER THE REFERENCE AND BOTH ENERGY [R]EVOLUTION SCENARIOS** IN PJ/a

		2012	2020	2030	2040	2050
BIOMASS	REF	2,387	3,167	3,441	4,007	4,717
	E[R]	2,387	3,448	3,712	3,770	3,874
	ADV	2,387	3,448	3,712	3,770	3,940
SOLAR HEATING	REF	107	281	351	500	685
	E[R]	107	1,149	1,816	3,061	3,811
	ADV	107	1,149	1,816	3,209	4,016
GEOTHERMAL HEAT AND HEAT PUMPS	REF	179	301	344	467	620
	E[R]	179	1,030	1,870	4,018	5,080
	ADV	179	1,030	1,870	4,108	5,301
HYDROGEN	REF	0	0	0	0	0
	E[R]	0	0	3	132	627
	ADV	0	48	174	756	2,283
TOTAL	REF	2,673	3,749	4,135	4,974	6,022
	E[R]	2,673	5,627	7,401	10,981	13,393
	ADV	2,673	5,675	7,572	11,842	15,540

**FIGURE 6.4.8 | OECD EUROPE: PROJECTION OF HEAT SUPPLY BY ENERGY CARRIER – REFERENCE, ENERGY [R]EVOLUTION, ADVANCED ENERGY [R]EVOLUTION SCENARIOS**



### 6.4.6 FUTURE INVESTMENTS IN THE HEATING SECTOR

Also in the heating sector the Energy [R]evolution scenarios would require a major revision of current investment strategies in heating technologies. In particular, solar thermal, geothermal and heat pump technologies need an enormous increase in installations if these potentials are to be tapped for the heating sector. The use of biomass for heating purposes - often traditional biomass today - will be substantially reduced in the Energy [R]evolution scenarios and replaced by more efficient and sustainable renewable heating technologies.

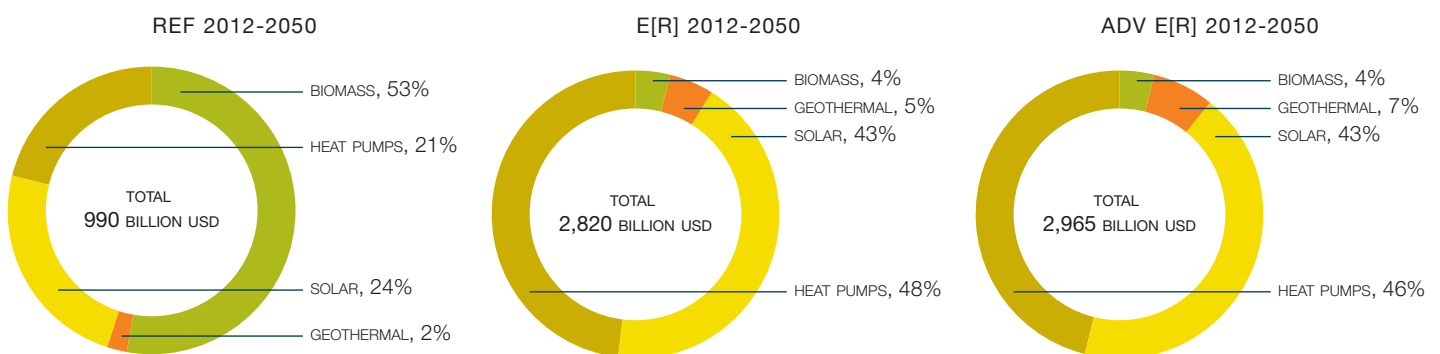
Renewable heating technologies are extremely variable, from low tech biomass stoves and unglazed solar collectors to very sophisticated enhanced geothermal and solar systems. Thus, it can only be roughly estimated that the Energy [R]evolution scenario in total requires around US\$ 2,820 billion to be invested in renewable heating technologies up to 2050 (including investments for replacement after the economic lifetime of the plants) - approximately US\$ 72 billion per year. The Advanced scenario assumes an even more ambitious expansion of renewable technologies resulting in an average investment of around US\$ 76 billion per year, while the main strategy in the scenario is the substitution of the remaining natural gas amounts with hydrogen or other synthetic fuels.

**TABLE 6.4.3 | OECD EUROPE: INSTALLED CAPACITIES FOR RENEWABLE HEAT GENERATION UNDER THE SCENARIOS** IN GW

		2012	2020	2030	2040	2050
BIOMASS	REF	419	479	530	588	645
	E[R]	419	448	417	372	322
	ADV	419	448	417	372	322
GEOTHERMAL	REF	2	3	5	8	9
	E[R]	2	5	37	77	85
	ADV	2	5	37	77	100
SOLAR HEATING	REF	32	63	104	148	202
	E[R]	32	109	517	836	1,021
	ADV	32	109	517	881	1,087
HEAT PUMPS	REF	30	42	56	75	101
	E[R]	30	74	245	478	611
	ADV	30	74	245	492	631
TOTAL*	REF	482	588	695	819	957
	E[R]	482	636	1,216	1,763	2,039
	ADV	482	636	1,216	1,822	2,140

\* Excluding direct electric heating.

**FIGURE 6.4.9 | OECD EUROPE: DEVELOPMENT OF INVESTMENTS FOR RENEWABLE HEAT GENERATION TECHNOLOGIES – REFERENCE, ENERGY [R]EVOLUTION, ADVANCED ENERGY [R]EVOLUTION SCENARIOS**



#### 6.4.7 FUTURE EMPLOYMENT IN THE ENERGY SECTOR

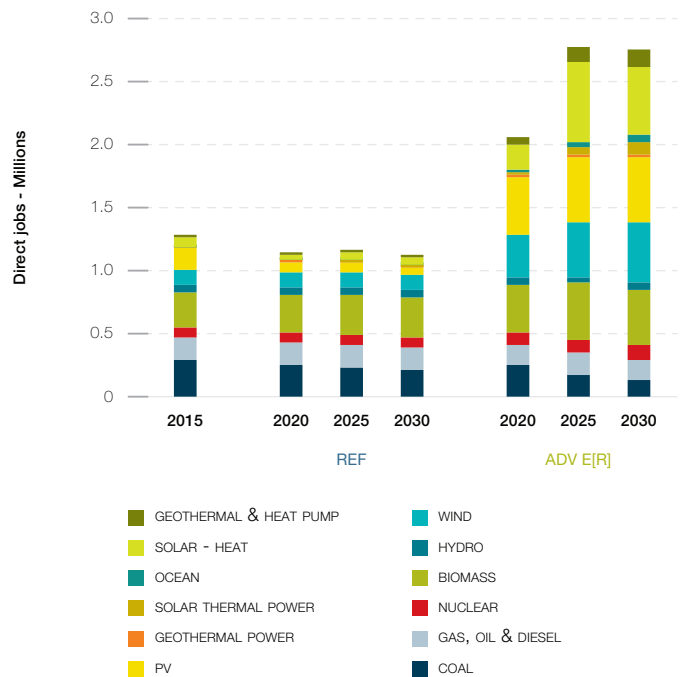
The Advanced Energy [R]evolution scenario results in more energy sector jobs in OECD Europe at every stage of the projection.

- There are 2.1 million energy sector jobs in the Advanced Energy [R]evolution in 2020, and 1.1 million in the Reference scenario.
- In 2025, there are 2.8 million jobs in the Advanced Energy [R]evolution scenario, and 1.2 million in the Reference scenario.
- In 2030, there are 2.8 million jobs in the Advanced Energy [R]evolution scenario and 1.1 million in the Reference scenario.

Figure 6.4.10 shows the change in job numbers under both scenarios for each technology between 2015 and 2030. Jobs in the coal sector decline in both scenarios, and there is an overall decline of 12% in energy sector jobs in the Reference scenario.

Strong growth in renewable energy leads to an increase of 61% in total energy sector jobs in the Advanced Energy [R]evolution scenario by 2020. Jobs continue to rise, and are more than double 2015 levels in both 2025 and 2030. Renewable energy accounts for 85% of energy jobs by 2030, with solar heating having the greatest share (20%), followed by solar PV, wind, and biomass.

**FIGURE 6.4.10 | OECD EUROPE: EMPLOYMENT IN THE ENERGY SECTOR UNDER THE REFERENCE AND ADVANCED ENERGY [R]EVOLUTION SCENARIOS**



**TABLE 6.4.4 | OECD EUROPE: TOTAL EMPLOYMENT IN THE ENERGY SECTOR IN THOUSAND JOBS**

	2015	2020	REFERENCE		ADVANCED ENERGY [R]EVOLUTION		
			2025	2030	2020	2025	2030
COAL	294	253	228	209	246	177	135
GAS, OIL & DIESEL	175	178	180	176	162	166	157
NUCLEAR	84	82	81	80	96	101	110
RENEWABLES	725	631	662	654	1,547	2,330	2,363
<b>TOTAL JOBS</b>	<b>1,278</b>	<b>1,145</b>	<b>1,152</b>	<b>1,120</b>	<b>2,051</b>	<b>2,774</b>	<b>2,764</b>
CONSTRUCTION AND INSTALLATION	203	125	142	135	560	1,001	934
MANUFACTURING	144	92	92	76	508	725	732
OPERATIONS AND MAINTENANCE	380	402	405	407	443	535	623
FUEL SUPPLY (DOMESTIC)	551	526	514	502	540	513	475
COAL AND GAS EXPORT	-	-	-	-	-	-	-
<b>TOTAL JOBS</b>	<b>1,278</b>	<b>1,145</b>	<b>1,152</b>	<b>1,120</b>	<b>2,051</b>	<b>2,774</b>	<b>2,764</b>



### 6.4.8 TRANSPORT

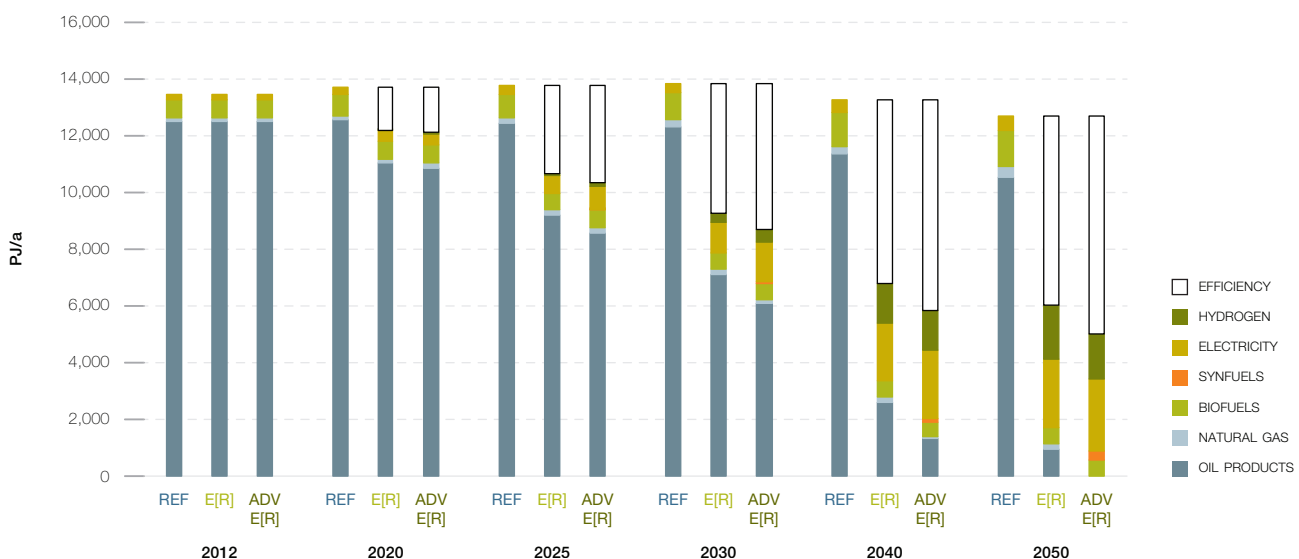
A key target in OECD Europe is to introduce incentives for people to drive smaller cars and buy new, more efficient vehicle concepts. In addition, it is vital to shift transport use to efficient modes like rail, light rail and buses, especially in the metropolitan areas. Along with rising prices for fossil fuels, these changes reduce the further growth in car sales projected under the Reference scenario. Due to population increase, GDP growth and higher living standards, energy demand from the transport sector is expected to only slightly decrease in the Reference scenario by around 6% to 12,700 PJ/a in 2050. In the basic Energy [R]evolution scenario, efficiency measures and modal shifts will save 53% (6,700 PJ/a) in 2050 compared to the Reference scenario.

Additional modal shifts and technology switches lead to even higher energy savings in the Advanced scenario of 60% (7,670 PJ/a) in 2050 compared to the Reference scenario. Highly efficient propulsion technology with hybrid, plug-in hybrid and battery-electric power trains will bring about large efficiency gains. By 2030, electricity will provide 11% of the transport sector's total energy demand in the Energy [R]evolution, while in 2050 the share will be 40% (51% in the Advanced scenario). Hydrogen and other synthetic fuels generated using renewable electricity are complementary options to further increase the renewable share in the transport sector. In 2050, more than 1,610 PJ/a of hydrogen is used in the transport sector for the Advanced Energy [R]evolution scenario.

**TABLE 6.4.5 | OECD EUROPE: PROJECTION OF TRANSPORT ENERGY DEMAND BY MODE IN THE REFERENCE AND THE ENERGY [R]EVOLUTION SCENARIOS** IN PJ/a

		2012	2020	2030	2040	2050
RAIL	REF	387	409	417	430	442
	E[R]	387	407	417	434	446
	ADV	387	422	570	743	866
ROAD	REF	12,527	12,545	12,557	11,937	11,328
	E[R]	12,527	11,069	8,157	5,690	4,925
	ADV	12,527	10,985	7,451	4,494	3,617
DOMESTIC AVIATION	REF	262	450	491	507	518
	E[R]	262	380	410	390	370
	ADV	262	376	385	339	296
DOMESTIC NAVIGATION	REF	238	331	331	338	341
	E[R]	238	290	265	247	240
	ADV	238	290	265	247	240
TOTAL	REF	13,414	13,735	13,796	13,213	12,629
	E[R]	13,414	12,146	9,249	6,761	5,980
	ADV	13,414	12,074	8,671	5,823	5,019

**FIGURE 6.4.11 | OECD EUROPE: FINAL ENERGY CONSUMPTION IN TRANSPORT UNDER THE SCENARIOS**



### 6.4.10 DEVELOPMENT OF CO<sub>2</sub> EMISSIONS

Whilst OECD Europe's emissions of CO<sub>2</sub> will decrease by 10% between 2012 and 2050 under the Reference scenario, under the Energy [R]evolution scenario they will decrease from 3,720 million tonnes in 2012 to 329 million tonnes in 2050. Annual per capita emissions will drop from 6.6 tonne to 0.5 tonne. In spite of the abstinence of nuclear power production and increasing power demand, CO<sub>2</sub> emissions will decrease in the electricity sector. In the long run efficiency gains and the increased use of renewable electricity in vehicles strongly reduce emissions in the transport sector as well.

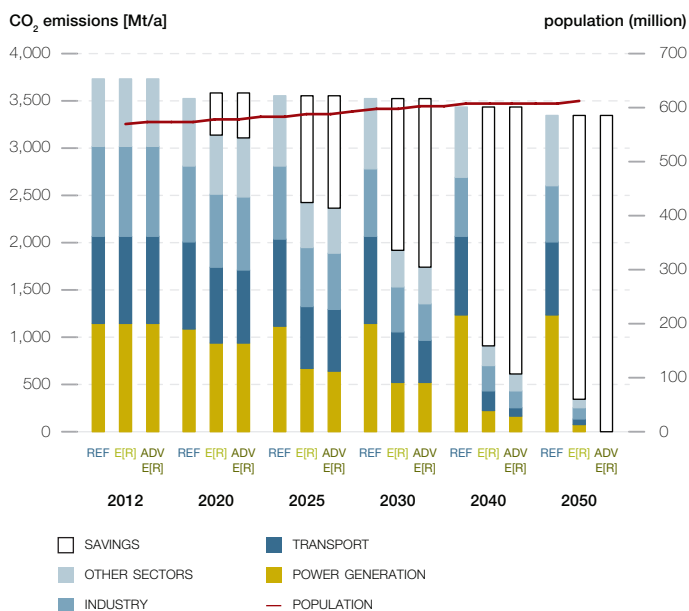
With a 31% share of CO<sub>2</sub>, the Industry sector will be the largest source of emissions in 2050 in the basic Energy [R]evolution scenario. By 2050, OECD Europe's CO<sub>2</sub> emissions are around 92% below 1990 levels in the Energy [R]evolution scenario while energy consumption is fully decarbonised in the Advanced case.

### 6.4.11 PRIMARY ENERGY CONSUMPTION

Taking into account the assumptions discussed above, the resulting primary energy consumption under the Energy [R]evolution scenarios is shown in Figure 6.4.12. Under the basic Energy [R]evolution scenario, primary energy demand will decrease by 44% from today's 72,960 PJ/a to around 41,000 PJ/a. Compared to the Reference scenario, overall primary energy demand will be reduced by 46% in 2050 under the Energy [R]evolution scenario (Reference scenario: around 76,000 PJ in 2050). The Advanced scenario results due to additional conversion losses in a primary energy consumption of around 42,400 PJ in 2050.

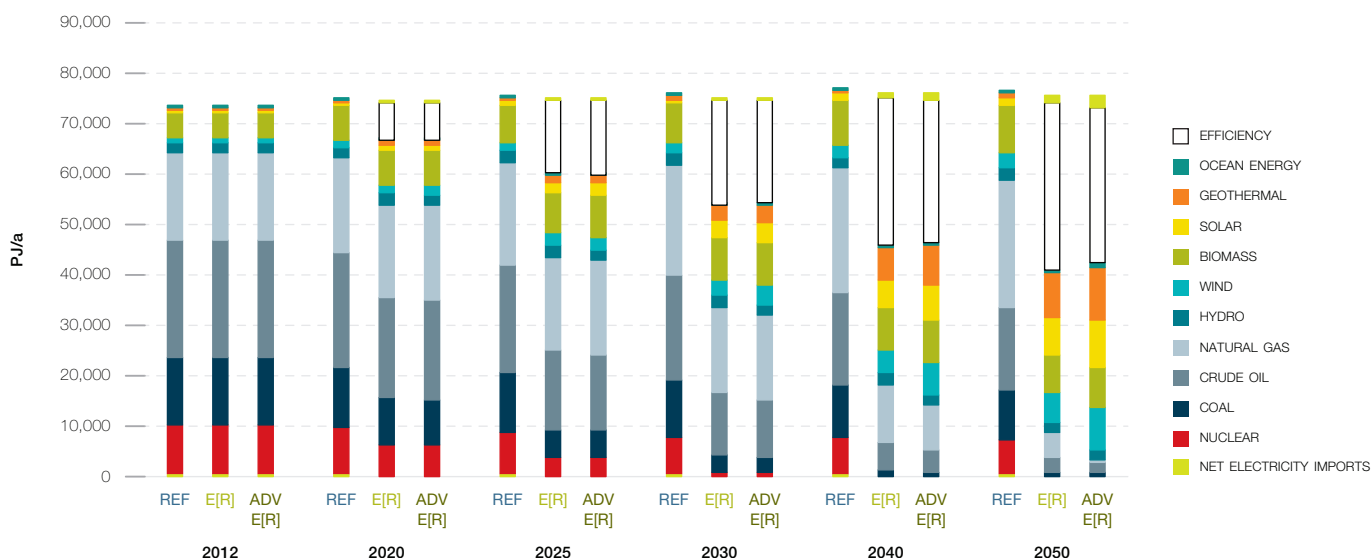
The Energy [R]evolution scenarios aim to phase out coal and oil as fast as technically and economically possible by expansion

**FIGURE 6.4.13 | OECD EUROPE: DEVELOPMENT OF CO<sub>2</sub> EMISSIONS BY SECTOR UNDER THE ENERGY [R]EVOLUTION SCENARIOS** 'SAVINGS' = REDUCTION COMPARED TO THE REFERENCE SCENARIO



of renewable energies and a fast introduction of very efficient vehicle concepts in the transport sector to replace oil based combustion engines. This leads to an overall renewable primary energy share of 37% in 2030 and 79% in 2050 in the basic Energy [R]evolution and of more than 92% in 2050 in the Advanced case (incl. non-energy consumption). In contrast to the Reference scenario, no new nuclear power plants will be built in OECD Europe in the Energy [R]evolution scenarios.

**FIGURE 6.4.12 | OECD EUROPE: PROJECTION OF TOTAL PRIMARY ENERGY DEMAND (PED) BY ENERGY CARRIER INCLUDING ELECTRICITY** INCLUDING ELECTRICITY IMPORT BALANCE – REFERENCE, ENERGY [R]EVOLUTION, ADVANCED ENERGY [R]EVOLUTION SCENARIOS



**TABLE 6.4.6 | OECD EUROPE: ACCUMULATED INVESTMENT COSTS FOR ELECTRICITY GENERATION AND FUEL COST SAVINGS UNDER THE ENERGY [R]EVOLUTION SCENARIO COMPARED TO THE REFERENCE SCENARIO**

ACCUMULATED INVESTMENT COSTS DIFFERENCE REF MINUS E[R]	UNIT	2012-2020	2021-2030	2031-2040	2041-2050	2012-2050	2012 - 2050 AVERAGE PER YEAR
CONVENTIONAL (FOSSIL + NUCLEAR)	BILLION \$	102.6	123.7	215.0	224.1	665.5	17.1
RENEWABLES (INCL. CHP)	BILLION \$	-198.0	-659.0	-812.6	-789.4	-2,459.2	-63.1
TOTAL	BILLION \$	-95.4	-535.3	-597.6	-565.3	-1,793.6	-46.0
<b>ACCUMULATED FUEL COST SAVINGS</b>							
SAVINGS CUMULATIVE E[R] VERSUS REF							
FUEL OIL	BILLION \$	2.0	28.3	24.8	11.4	66.5	1.7
GAS	BILLION \$	-21.3	179.6	760.1	1,416.8	2,335.2	59.9
HARD COAL	BILLION \$	16.1	122.7	224.0	273.6	636.5	16.3
LIGNITE	BILLION \$	4.6	42.5	59.2	58.9	165.1	4.2
NUCLEAR ENERGY	BILLION \$	13.4	84.7	144.1	165.7	407.9	10.5
TOTAL	BILLION \$	14.7	457.8	1,212.2	1,926.4	3,611.2	92.6

**TABLE 6.4.7 | OECD EUROPE: ACCUMULATED INVESTMENT COSTS FOR RENEWABLE HEAT GENERATION UNDER THE ENERGY [R]EVOLUTION SCENARIO COMPARED TO THE REFERENCE SCENARIO**

ACCUMULATED INVESTMENT COSTS DIFFERENCE REF MINUS E[R]	UNIT	2012-2020	2021-2030	2031-2040	2041-2050	2012-2050	2012 - 2050 AVERAGE PER YEAR
RENEWABLES	BILLION \$	26.5	429.1	657.4	713.2	1,826.2	46.8

**TABLE 6.4.8 | OECD EUROPE: ACCUMULATED INVESTMENT COSTS FOR ELECTRICITY GENERATION AND FUEL COST SAVINGS UNDER THE ADVANCED ENERGY [R]EVOLUTION SCENARIO COMPARED TO THE REFERENCE SCENARIO**

ACCUMULATED INVESTMENT COSTS DIFFERENCE REF MINUS ADVANCED E[R]	UNIT	2012-2020	2021-2030	2031-2040	2041-2050	2012-2050	2012 - 2050 AVERAGE PER YEAR
CONVENTIONAL (FOSSIL + NUCLEAR)	BILLION \$	125.1	119.4	225.9	208.8	679.2	17.4
RENEWABLES (INCL. CHP)	BILLION \$	-224.2	-1,011.8	-1,256.5	-1,274.7	-3,767.3	-96.6
TOTAL	BILLION \$	-99.1	-892.4	-1,030.6	-1,065.9	-3,088.1	-79.2
<b>ACCUMULATED FUEL COST SAVINGS</b>							
SAVINGS CUMULATIVE ADVANCED E[R] VERSUS REF							
FUEL OIL	BILLION \$	2.0	28.3	24.8	11.4	66.5	1.7
GAS	BILLION \$	-21.3	186.3	807.4	1,521.5	2,494.0	63.9
HARD COAL	BILLION \$	16.6	125.3	228.5	276.2	646.6	16.6
LIGNITE	BILLION \$	4.6	42.5	59.2	58.9	165.1	4.2
NUCLEAR ENERGY	BILLION \$	13.4	84.7	144.1	165.7	407.9	10.5
TOTAL	BILLION \$	15.2	467.1	1,264.0	2,033.7	3,780.0	96.9

**TABLE 6.4.9 | ACCUMULATED INVESTMENT COSTS FOR RENEWABLE HEAT GENERATION UNDER THE ADVANCED ENERGY [R]EVOLUTION SCENARIO COMPARED TO THE REFERENCE SCENARIO**

ACCUMULATED INVESTMENT COSTS DIFFERENCE REF MINUS ADVANCED E[R]	UNIT	2012-2020	2021-2030	2031-2040	2041-2050	2012-2050	2012 - 2050 AVERAGE PER YEAR
RENEWABLES	BILLION \$	26.5	429.1	716.0	801.0	1,972.5	50.6

## 6.5 AFRICA

### 6.5.1 FINAL ENERGY DEMAND BY SECTOR

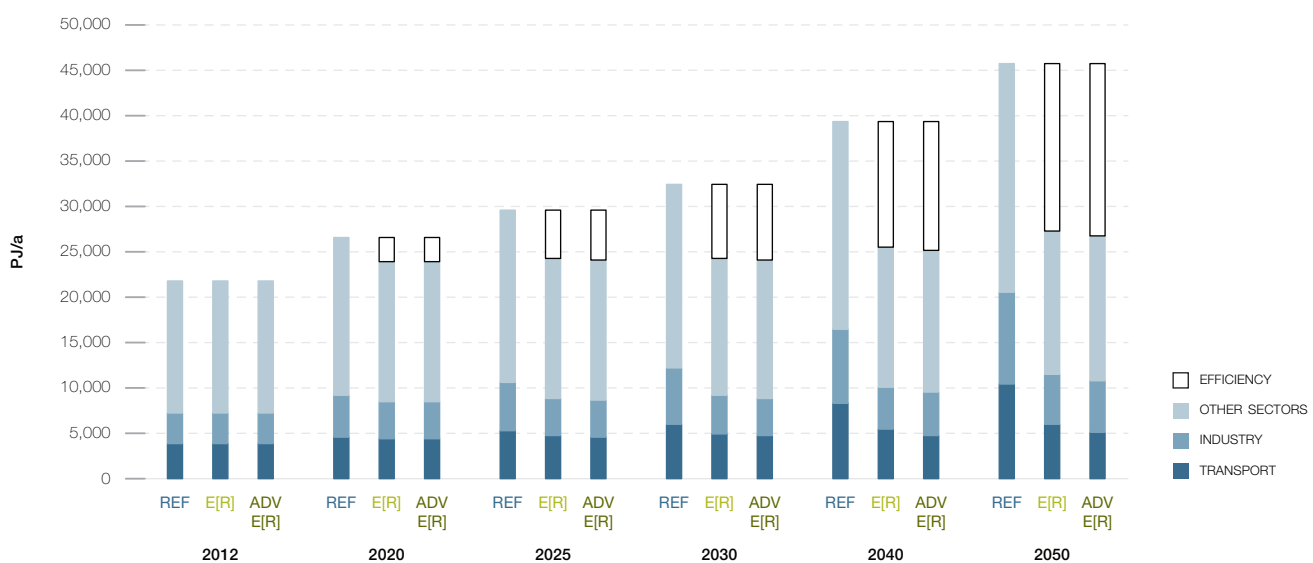
Combining the projections on population development, GDP growth and energy intensity results in future development pathways for Africa's final energy demand. These are shown in Figure 6.5.1 for the Reference and Energy [R]evolution scenarios. Under the Reference scenario, total final energy demand increases by 111% from the current 21,700 PJ/a to 45,700 PJ/a in 2050. In the basic Energy [R]evolution scenario, final energy demand increases at a much lower rate by 26% compared to current consumption and is expected to reach 27,300 PJ/a by 2050. The Advanced scenario results in some additional reductions due to a higher share of electric cars.

Under both Energy [R]evolution scenarios, due to economic growth, increasing living standards and electrification of the transport sector, overall electricity demand is expected to increase despite efficiency gains in all sectors (see Figure 6.5.2). Total electricity demand will rise from about 590 TWh/a to 2,890 TWh/a by 2050 in the basic Energy [R]evolution scenario. Compared to the Reference scenario, efficiency measures in the industry, residential and service sectors avoid the generation of about 360 TWh/a.

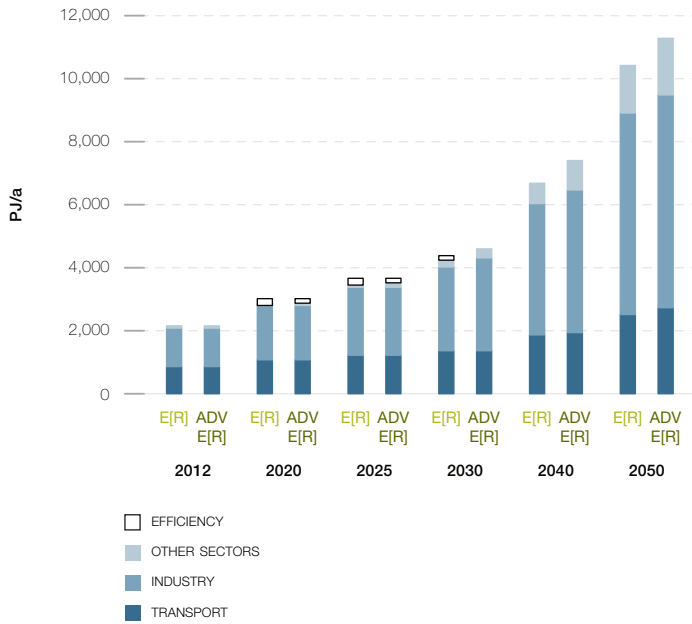
This reduction can be achieved in particular by introducing highly efficient electronic devices using the best available technology in all demand sectors. The transformation to a carbon free energy system in the Advanced scenario will further increase the electricity demand in 2050 up to 3,100 TWh/a. Electricity will become the major renewable 'primary' energy, not only for direct use for various purposes but also for the generation of synthetic fuels for fossil fuels substitution. Around 490 TWh are used in 2050 for electric vehicles and rail transport in 2050 in the Advanced scenario, around 560 TWh for hydrogen and 790 TWh for synthetic liquid fuel generation for the transport sector (excluding bunkers).

Efficiency gains in the heating sector are even larger than in the electricity sector. Under the Energy [R]evolution scenarios, consumption equivalent to about 3,600 PJ/a is avoided through efficiency gains by 2050 compared to the Reference scenario. As a result of the introduction of low energy standards and highly efficient technologies e.g. for industrial and commercial process heat, cooking and air conditioning, enjoyment of the same comfort and energy services will be accompanied by much lower future energy demand.

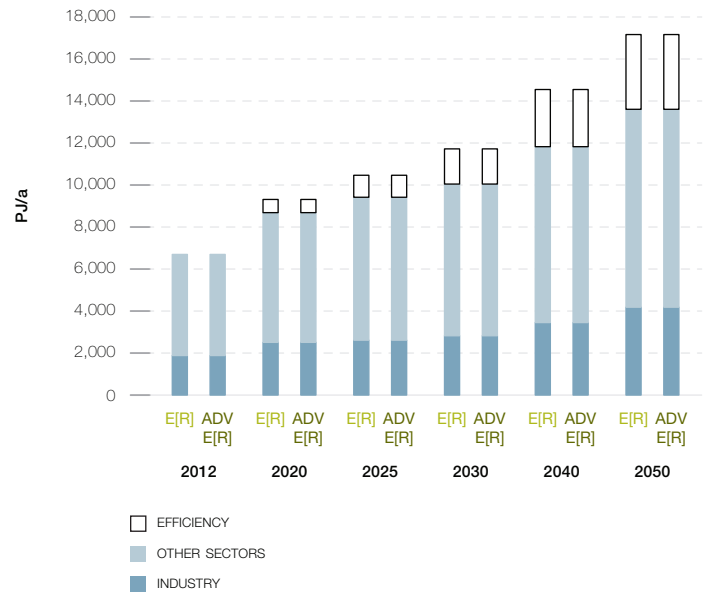
**FIGURE 6.5.1 | AFRICA: PROJECTION OF TOTAL FINAL ENERGY DEMAND BY SECTOR – REFERENCE, ENERGY [R]EVOLUTION, ADVANCED ENERGY [R]EVOLUTION SCENARIOS** WITHOUT NON-ENERGY USE AND HEAT FROM CHP AUTOPRODUCERS



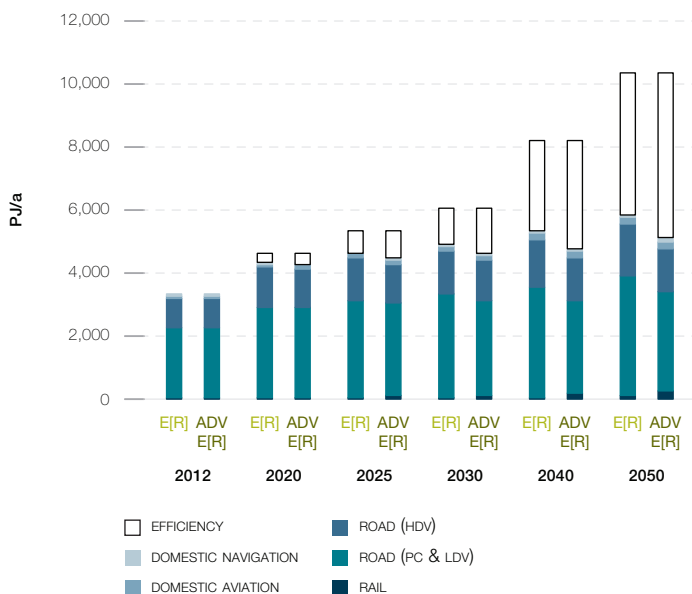
**FIGURE 6.5.2 | AFRICA: DEVELOPMENT OF ELECTRICITY DEMAND BY SECTOR IN THE ENERGY [R]EVOLUTION SCENARIOS**



**FIGURE 6.5.4 | AFRICA: DEVELOPMENT OF FINAL ENERGY DEMAND FOR HEAT BY SECTOR IN THE ENERGY [R]EVOLUTION SCENARIOS**



**FIGURE 6.5.3 | AFRICA: DEVELOPMENT OF THE FINAL ENERGY DEMAND FOR TRANSPORT BY SECTOR IN THE ENERGY [R]EVOLUTION SCENARIOS**



### 6.5.2 ELECTRICITY GENERATION

The development of the electricity supply sector is characterised by a dynamically growing renewable energy market and an increasing share of renewable electricity. This trend will more than compensate for the phasing out of nuclear power production in the Energy [R]evolution scenarios, continuously reducing the number of fossil fuel-fired power plants as well. By 2050, 95% of the electricity produced in Africa will come from renewable energy sources in the basic Energy [R]evolution scenario. ‘New’ renewables – mainly wind, PV, CSP and geothermal energy – will contribute 80% to the total electricity generation. Already by 2020 the share of renewable electricity production will be 31% and 65% by 2030. The installed capacity of renewables will reach about 380 GW in 2030 and 1,390 GW by 2050.

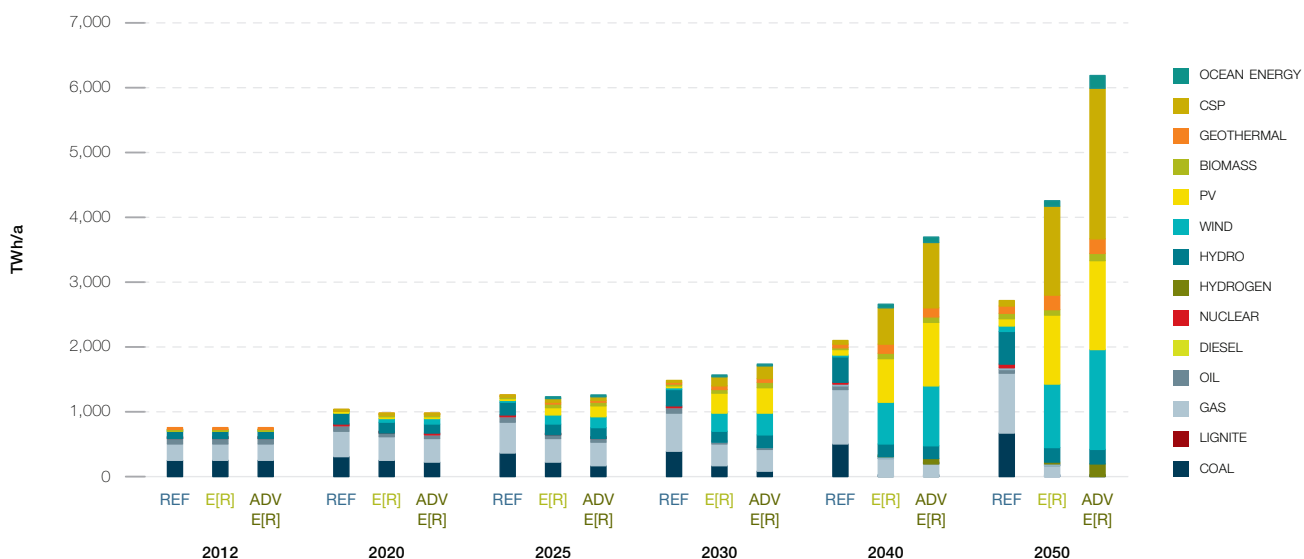
A 100% electricity supply from renewable energy resources in the Advanced scenario leads to around 2,000 GW installed generation capacity in 2050.

Table 6.5.1 shows the comparative evolution of the different renewable technologies in Africa over time. Until 2020 hydro will remain the main renewable power source. By 2020 wind and PV overtake biomass, currently the second largest contributor to the growing renewable market. After 2020, the continuing growth of wind and PV will be complemented by electricity from solar thermal, geothermal and ocean energy. The Energy [R]evolution scenarios will lead to a high share of fluctuating power generation sources (PV, wind and ocean) of already 38% to 45% by 2030 and 50% 2050. Therefore, smart grids, demand side management (DSM), energy storage capacities and other options need to be expanded in order to increase the flexibility of the power system for grid integration, load balancing and a secure supply of electricity.

**TABLE 6.5.1 | AFRICA: PROJECTION OF RENEWABLE ELECTRICITY GENERATION CAPACITY UNDER THE REFERENCE AND THE ENERGY [R]EVOLUTION SCENARIOS** IN GW

		2012	2020	2030	2040	2050
HYDRO	REF	25	38	60	86	119
	E[R]	25	34	41	47	53
	ADV	25	34	41	47	53
BIOMASS	REF	0	2	6	9	14
	E[R]	0	4	13	15	17
	ADV	0	5	15	21	30
WIND	REF	1	5	12	19	30
	E[R]	1	23	102	220	333
	ADV	1	26	124	333	541
GEOTHERMAL	REF	0	1	4	9	18
	E[R]	0	1	10	20	34
	ADV	0	1	10	20	34
PV	REF	0	6	21	40	69
	E[R]	0	28	177	423	669
	ADV	0	31	250	598	847
CSP	REF	0	1	4	11	20
	E[R]	0	7	30	113	239
	ADV	0	7	48	199	411
OCEAN	REF	0	0	0	0	0
	E[R]	0	0	9	25	50
	ADV	0	0	9	45	90
TOTAL	REF	26	54	105	175	271
	E[R]	26	96	381	863	1,394
	ADV	26	104	497	1,264	2,004

**FIGURE 6.5.5 | AFRICA: DEVELOPMENT OF ELECTRICITY GENERATION STRUCTURE – REFERENCE, ENERGY [R]EVOLUTION, ADVANCED ENERGY [R]EVOLUTION SCENARIOS**



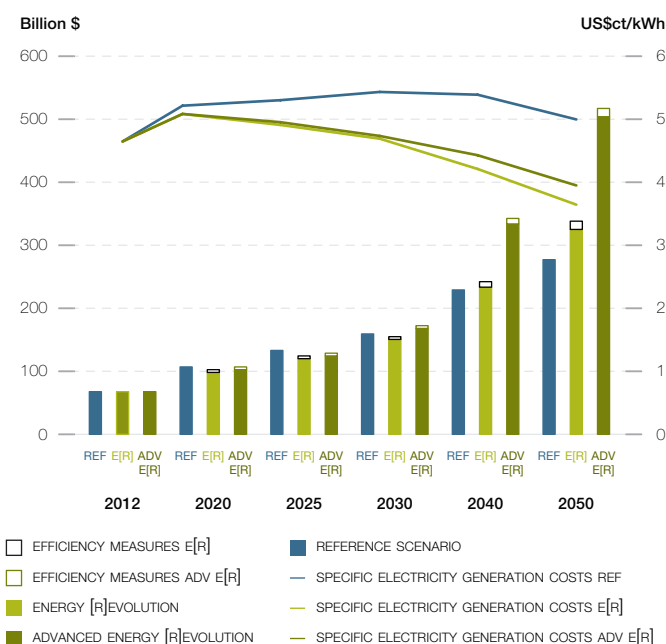
### 6.5.3 FUTURE COSTS OF ELECTRICITY GENERATION

Figure 6.5.6 shows that the introduction of renewable technologies under both Energy [R]evolution scenarios decreases the future costs of electricity generation compared to the Reference scenario by 2030. The difference in full cost of generation will be around 1.4 US\$ct/kWh in the basic Energy [R]evolution and around 1.3 US\$ct/kWh in the Advanced scenario, without taking into account integration costs for storage or other load-balancing measures. Because of increasing prices for conventional fuels, electricity generation costs will become economically favourable starting just after 2020 under the Energy [R]evolution scenarios. By 2050, the cost will be 2.8/2.1 US\$ct/kWh, respectively, below those in the Reference case.

Under the Reference scenario, on the other hand, growth in demand and increasing fossil fuel prices result in total electricity supply costs rising from today's US\$ 67 billion per year to more than US\$ 277 billion in 2050, compared to US\$ 326 billion in the basic Energy [R]evolution and US\$ 507 billion in the Advanced Energy [R]evolution scenario. Figure 6.5.6 shows that both Energy [R]evolution scenarios not only comply with Africa's CO<sub>2</sub> reduction targets, but also help stabilise energy costs and relieve the economic pressure on society.

Increasing energy efficiency and shifting energy supply to renewables lead to long term total costs for electricity supply that are only 18% higher in the basic Energy [R]evolution scenario than in the Reference scenario, despite a 57% increase in electricity production. The Advanced scenario with 100% renewable power and more than a doubling of generation results in supply costs 83% higher than the Reference case.

**FIGURE 6.5.6 | AFRICA: DEVELOPMENT OF TOTAL ELECTRICITY SUPPLY COSTS & OF SPECIFIC ELECTRICITY GENERATION COSTS IN THE SCENARIOS**



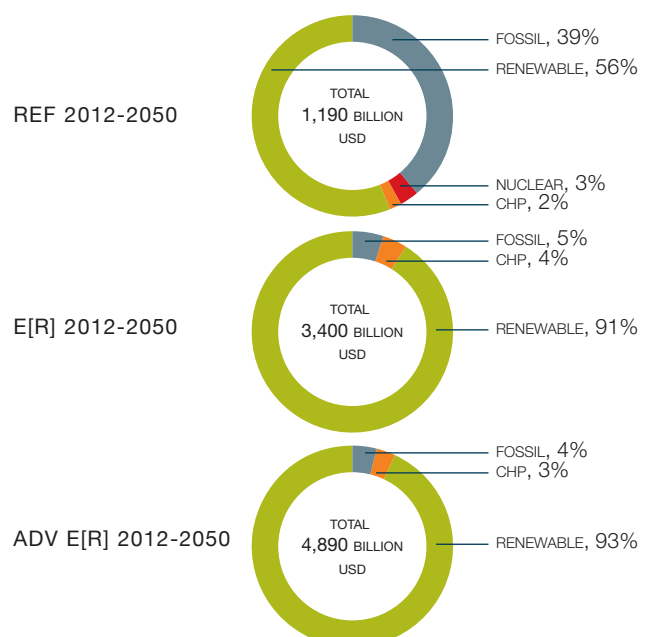
### 6.5.4 FUTURE INVESTMENTS IN THE POWER SECTOR

Around US\$ 3,410 billion is required in investment for the Energy [R]evolution scenario to become reality (including investments for replacement after the economic lifetime of the plants) - approximately US\$ 87 billion per year, US\$ 2,220 billion more than in the Reference scenario (US\$ 1,190 billion). Investments for the Advanced scenario sum up to US\$ 4,890 billion until 2050, on average US\$ 125 billion per year. Under the Reference scenario, the levels of investment in conventional power plants add up to almost 42% while approximately 58% would be invested in renewable energies and cogeneration until 2050.

Under the Energy [R]evolution scenarios, however, Africa would shift almost 95%/96% of the entire investment towards renewables and cogeneration, respectively. By 2030, the fossil fuel share of power sector investment would be focused mainly on gas power plants.

Because renewable energy has no fuel costs, the fuel cost savings in the basic Energy [R]evolution scenario reach a total of US\$ 2,500 billion up to 2050, US\$ 64 billion per year. The total fuel cost savings therefore would cover 110% of the total additional investments compared to the Reference scenario. Fuel cost savings in the Advanced scenario are even higher and add up to US\$ 2,670 billion, or US\$ 68 billion per year. Renewable energy sources would then go on to produce electricity without any further fuel costs beyond 2050, while costs for coal and gas will continue to be a burden on national economies.

**FIGURE 6.5.7 | AFRICA: INVESTMENT SHARES - REFERENCE VERSUS ENERGY [R]EVOLUTION SCENARIOS**



### 6.5.5 ENERGY SUPPLY FOR HEATING

Today, traditional biomass use meets around 60% of Africa’s energy demand for heat. Incentives to move to improved and modern biomass technologies are vital to enhance efficiency and to keep biomass consumption in check. Dedicated support instruments are required to ensure a dynamic development in particular for renewable technologies for buildings and renewable process heat production. In the basic Energy [R]evolution scenario, renewables already provide 68% of Africa’s total heat demand in 2030 and 91% in 2050.

- Energy efficiency measures help to reduce the currently growing energy demand for heating and cooking by 21% in 2050 (relative to the Reference scenario), in spite of improving living standards and economic growth.
- In the industry sector solar collectors, geothermal energy (incl. heat pumps) as well as electricity and hydrogen from renewable sources are increasingly substituting for fossil fuel-fired systems.
- A shift from coal and oil to natural gas in the remaining conventional applications leads to a further reduction of CO<sub>2</sub> emissions.

Table 6.5.8 shows the development of different renewable technologies for heating in Africa over time. Although biomass remains the main contributor, its market share is decreasing and with it inefficient traditional biomass. After 2030, the continuing growth of solar collectors and a growing share of geothermal and environmental heat as well as heat from renewable hydrogen will further reduce the dependence on fossil fuels. The Advanced scenario results in a complete substitution of the remaining gas consumption by hydrogen generated from renewable electricity.

**TABLE 6.5.2 | AFRICA: PROJECTION OF RENEWABLE HEAT SUPPLY UNDER THE REFERENCE AND BOTH ENERGY [R]EVOLUTION SCENARIOS** IN PJ/a

		2012	2020	2030	2040	2050
BIOMASS	REF	4,334	5,796	6,354	7,349	8,180
	E[R]	4,334	5,185	5,346	5,664	5,213
	ADV	4,334	5,185	5,346	5,690	5,540
SOLAR HEATING	REF	5	33	50	104	186
	E[R]	5	203	701	1,819	3,336
	ADV	5	203	701	1,819	3,315
GEOHERMAL HEAT AND HEAT PUMPS	REF	0	0	0	0	0
	E[R]	0	94	213	558	944
	ADV	0	94	213	570	992
HYDROGEN	REF	0	0	0	0	0
	E[R]	0	0	0	56	379
	ADV	0	0	0	387	914
TOTAL	REF	4,339	5,830	6,403	7,454	8,366
	E[R]	4,339	5,482	6,260	8,098	9,871
	ADV	4,339	5,482	6,260	8,464	10,760

**FIGURE 6.5.8 | AFRICA: PROJECTION OF HEAT SUPPLY BY ENERGY CARRIER – REFERENCE, ENERGY [R]EVOLUTION, ADVANCED ENERGY [R]EVOLUTION SCENARIOS**





### 6.5.6 FUTURE INVESTMENTS IN THE HEATING SECTOR

Also in the heating sector the Energy [R]evolution scenarios would require a major revision of current investment strategies in heating technologies. In particular, solar thermal, geothermal and heat pump technologies need an enormous increase in installations if these potentials are to be tapped for the heating sector. The use of biomass for heating purposes - often traditional biomass today - will be substantially reduced in the Energy [R]evolution scenarios and replaced by more efficient and sustainable renewable heating technologies.

Renewable heating technologies are extremely variable, from low tech biomass stoves and unglazed solar collectors to very sophisticated enhanced geothermal and solar systems. Thus, it can only be roughly estimated that the Energy [R]evolution scenario in total requires around US\$ 610 billion to be invested in renewable heating technologies up to 2050 (including investments for replacement after the economic lifetime of the plants) - approximately US\$ 16 billion per year. The Advanced scenario assumes an equally ambitious expansion of renewable technologies, while the main strategy in the scenario is the substitution of the remaining natural gas amounts with electricity, hydrogen or other synthetic fuels.

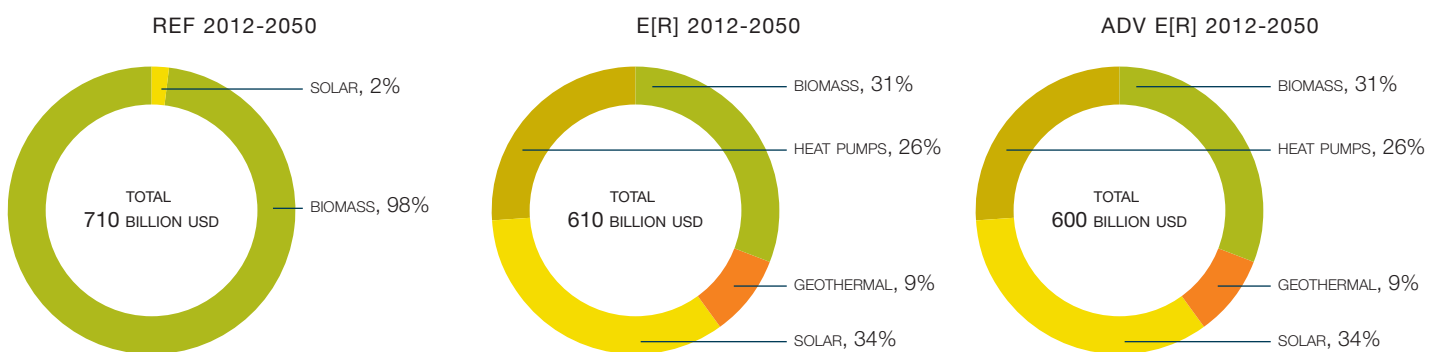
**TABLE 6.5.3 | AFRICA: INSTALLED CAPACITIES FOR RENEWABLE HEAT GENERATION UNDER THE SCENARIOS IN GW**

		2012	2020	2030	2040	2050
BIOMASS	REF	3,736	4,297	4,635	4,640	4,550
	E[R]	3,736	3,697	3,259	2,874	2,124
	ADV	3,736	3,697	3,259	2,874	2,245
GEOTHERMAL	REF	0	0	0	0	0
	E[R]	0	2	8	13	18
	ADV	0	2	8	13	18
SOLAR HEATING	REF	1	4	10	21	38
	E[R]	1	9	144	374	685
	ADV	1	9	144	374	685
HEAT PUMPS	REF	0	0	0	0	0
	E[R]	0	0	13	44	88
	ADV	0	0	13	44	88
TOTAL*	REF	3,736	4,300	4,645	4,661	4,588
	E[R]	3,736	3,708	3,425	3,305	2,917
	ADV	3,736	3,708	3,425	3,304	3,033

\* Excluding direct electric heating.

6

**FIGURE 6.5.9 | AFRICA: DEVELOPMENT OF INVESTMENTS FOR RENEWABLE HEAT GENERATION TECHNOLOGIES - REFERENCE, ENERGY [R]EVOLUTION, ADVANCED ENERGY [R]EVOLUTION SCENARIOS**



### 6.5.7 FUTURE EMPLOYMENT IN THE ENERGY SECTOR

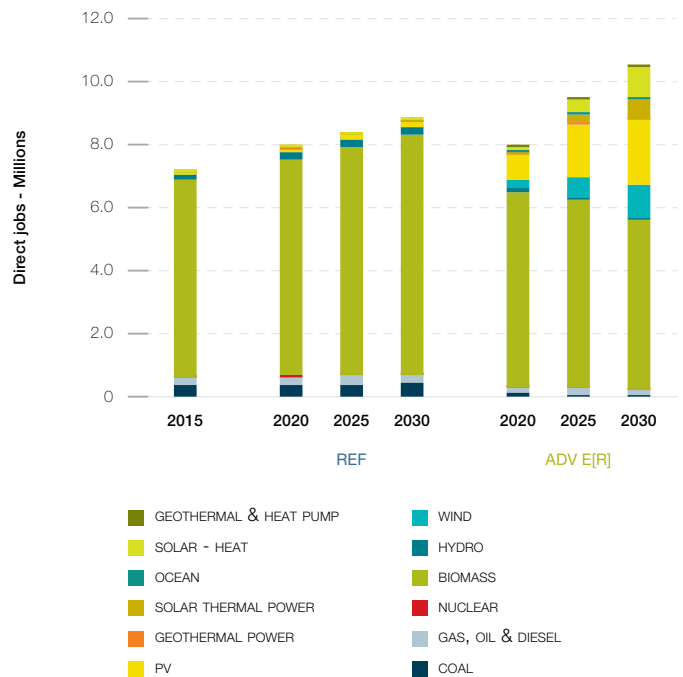
The Advanced Energy [R]evolution scenario results in more energy sector jobs in Africa from 2025 onwards.

- At 2020, there are 7.9 million energy sector jobs in both the Advanced Energy [R]evolution and the Reference scenario.
- In 2025, there are 9.5 million jobs in the Advanced Energy [R]evolution scenario, and 8.4 million in the Reference scenario.
- In 2030, there are 10.5 million jobs in the Advanced Energy [R]evolution scenario and 8.8 million in the Reference scenario.

Figure 6.5.10 shows the change in job numbers under both scenarios for each technology between 2015 and 2030. Jobs in the Reference scenario increase by 24% by 2030. Bioenergy accounts for by far the largest share of jobs in both scenarios.

The non-biomass renewable energy grows strongly in the Advanced Energy [R]evolution scenario. Until 2020 this offsets declines in bioenergy, so job levels are very close to the Reference scenario. Non-biomass renewable energy continues to grow strongly until , when to 48% above 2015. Renewable energy accounts for 98% of energy sector jobs by 2030.

**FIGURE 6.5.10 | AFRICA: EMPLOYMENT IN THE ENERGY SECTOR UNDER THE REFERENCE AND ADVANCED ENERGY [R]EVOLUTION SCENARIO**



**TABLE 6.5.4 | AFRICA: TOTAL EMPLOYMENT IN THE ENERGY SECTOR IN THOUSAND JOBS**

	2015	2020	REFERENCE		ADVANCED ENERGY [R]EVOLUTION		
			2025	2030	2020	2025	2030
COAL	376	391	391	420	111	79	42
GAS, OIL & DIESEL	223	247	263	278	171	183	169
NUCLEAR	16	23	27	29	8	9	8
RENEWABLES	6,521	7,264	7,702	8,096	7,628	9,197	10,309
<b>TOTAL JOBS</b>	<b>7,134</b>	<b>7,925</b>	<b>8,383</b>	<b>8,823</b>	<b>7,918</b>	<b>9,468</b>	<b>10,528</b>
CONSTRUCTION AND INSTALLATION	380	456	448	477	1,012	2,119	2,902
MANUFACTURING	165	184	185	204	253	644	1,105
OPERATIONS AND MAINTENANCE	235	308	384	413	453	787	1,213
FUEL SUPPLY (DOMESTIC)	6,315	6,930	7,313	7,668	6,174.5	5,900	5,298
COAL AND GAS EXPORT	40	46	53	60	25	18	10
<b>TOTAL JOBS</b>	<b>7,134</b>	<b>7,925</b>	<b>8,383</b>	<b>8,823</b>	<b>7,918</b>	<b>9,468</b>	<b>10,528</b>

### 6.5.8 TRANSPORT

In 2050, the car fleet in Africa will be significantly larger than today. Today, a large share of old cars are driven in Africa. With growing individual mobility, an increasing share of small efficient cars is projected in the Energy[R]evolution scenarios. Due to population increase, GDP growth and higher living standards, energy demand from the transport sector is expected to increase in the Reference scenario by around 170% to 10,400 PJ/a in 2050. In the basic Energy [R]evolution scenario, efficiency measures and modal shifts will save 43% (4,500 PJ/a) in 2050 compared to the Reference scenario.

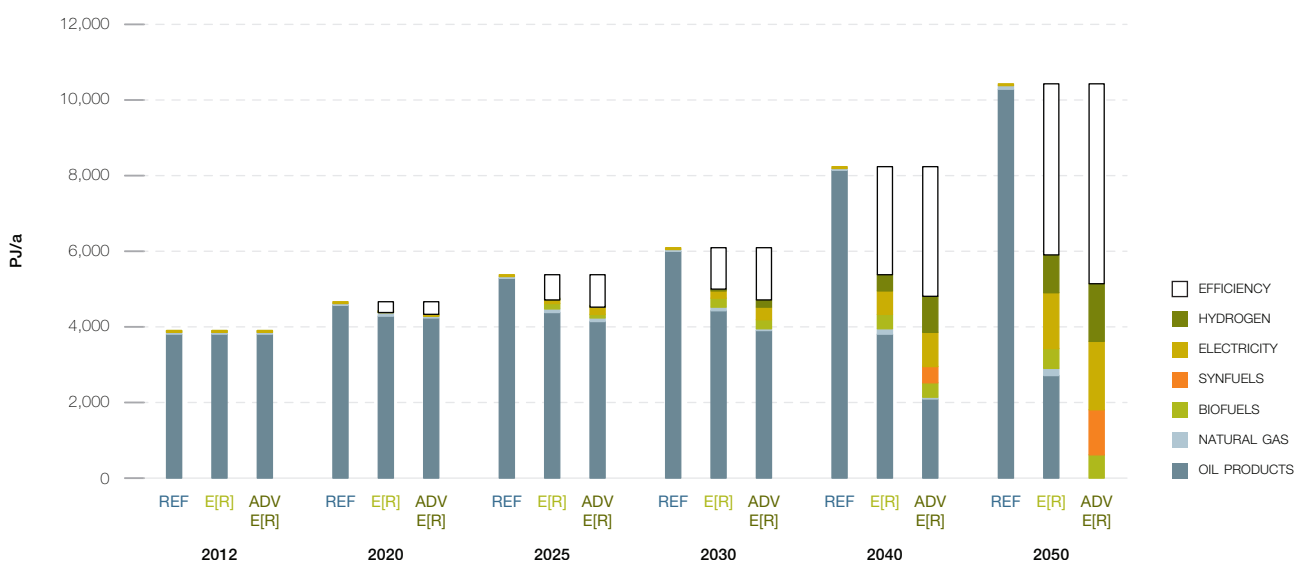
Additional modal shifts and technology switches lead to even higher energy savings in the Advanced scenario of 51% (5,260 PJ/a) in 2050 compared to the Reference scenario. Highly efficient propulsion technology with hybrid, plug-in hybrid and battery-electric power trains will bring about large efficiency gains. By 2030, electricity will provide 3% of the transport sector's total energy demand in the Energy [R]evolution, while in 2050 the share will be 25% (35% in the Advanced scenario). Hydrogen and other synthetic fuels generated using renewable electricity are complementary options to further increase the renewable share in the transport sector. In 2050, up to 1,540 PJ/a of hydrogen is used in the transport sector for the Advanced Energy [R]evolution scenario.

**TABLE 6.5.5 | AFRICA: PROJECTION OF TRANSPORT ENERGY DEMAND BY MODE IN THE REFERENCE AND THE ENERGY [R]EVOLUTION SCENARIOS** IN PJ/a

		2012	2020	2030	2040	2050
RAIL	REF	30	35	37	39	42
	E[R]	30	45	56	64	94
	ADV	30	56	113	162	283
ROAD	REF	3,143	5,110	5,786	7,839	9,881
	E[R]	3,143	4,131	4,663	4,991	5,436
	ADV	3,143	4,072	4,324	4,323	4,501
DOMESTIC AVIATION	REF	107	140	170	275	389
	E[R]	107	125	150	194	244
	ADV	107	125	148	190	229
DOMESTIC NAVIGATION	REF	28	30	31	31	32
	E[R]	28	45	62	81	89
	ADV	28	45	62	81	89
TOTAL	REF	3,307	5,315	6,023	8,184	10,345
	E[R]	3,307	4,346	4,931	5,330	5,863
	ADV	3,307	4,298	4,648	4,757	5,103

6

**FIGURE 6.5.11 | AFRICA: FINAL ENERGY CONSUMPTION IN TRANSPORT UNDER THE SCENARIOS**



### 6.5.10 DEVELOPMENT OF CO<sub>2</sub> EMISSIONS

Whilst Africa's emissions of CO<sub>2</sub> will increase by 149% between 2012 and 2050 under the Reference scenario, under the Energy [R]evolution scenario they will decrease from 1,050 million tonnes in 2012 to 363 million tonnes in 2050. Annual per capita emissions will drop from 1 tonne to 0.2 tonne. In spite of the abstinence of nuclear power production and increasing power demand, CO<sub>2</sub> emissions will decrease in the electricity sector. In the long run efficiency gains and the increased use of renewable electricity in vehicles strongly reduce emissions in the transport sector as well. With a 57% share of CO<sub>2</sub>, the Transport sector will be the largest source of emissions in 2050 in the basic E[R] scenario. By 2050, Africa's CO<sub>2</sub> emissions are 33% below 1990 levels in the Energy [R]evolution scenario while energy consumption is fully decarbonised in the Advanced case.

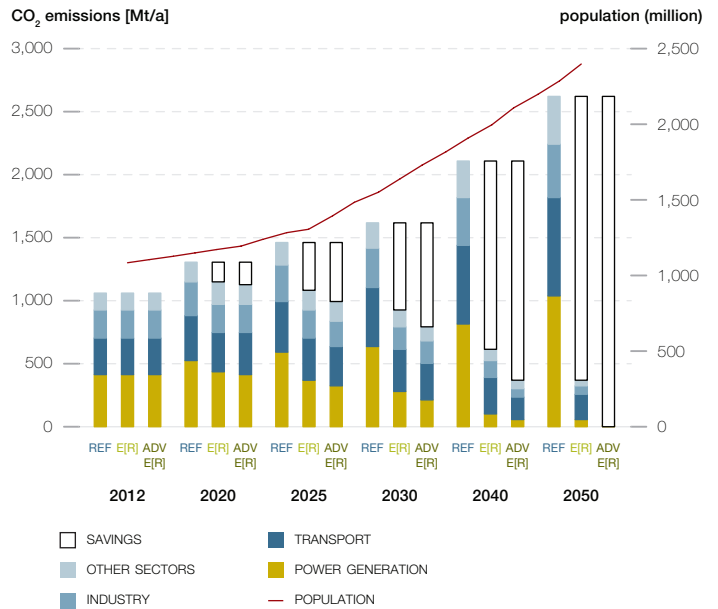
### 6.5.11 PRIMARY ENERGY CONSUMPTION

Taking into account the assumptions discussed above, the resulting primary energy consumption under the Energy [R]evolution scenarios is shown in Figure 6.5.12. Under the basic Energy [R]evolution scenario, primary energy demand will increase by 19% from today's 30,970 PJ/a to around 37,000 PJ/a. Compared to the Reference scenario, overall primary energy demand will be reduced by 44% in 2050 under the Energy [R]evolution scenario (Reference: around 367,000 PJ in 2050). The Advanced scenario results due to additional conversion losses in a primary energy consumption of around 39,500 PJ in 2050.

The Energy [R]evolution scenarios aim to phase out coal and oil as fast as technically and economically possible by expansion of renewable energies and a fast introduction of

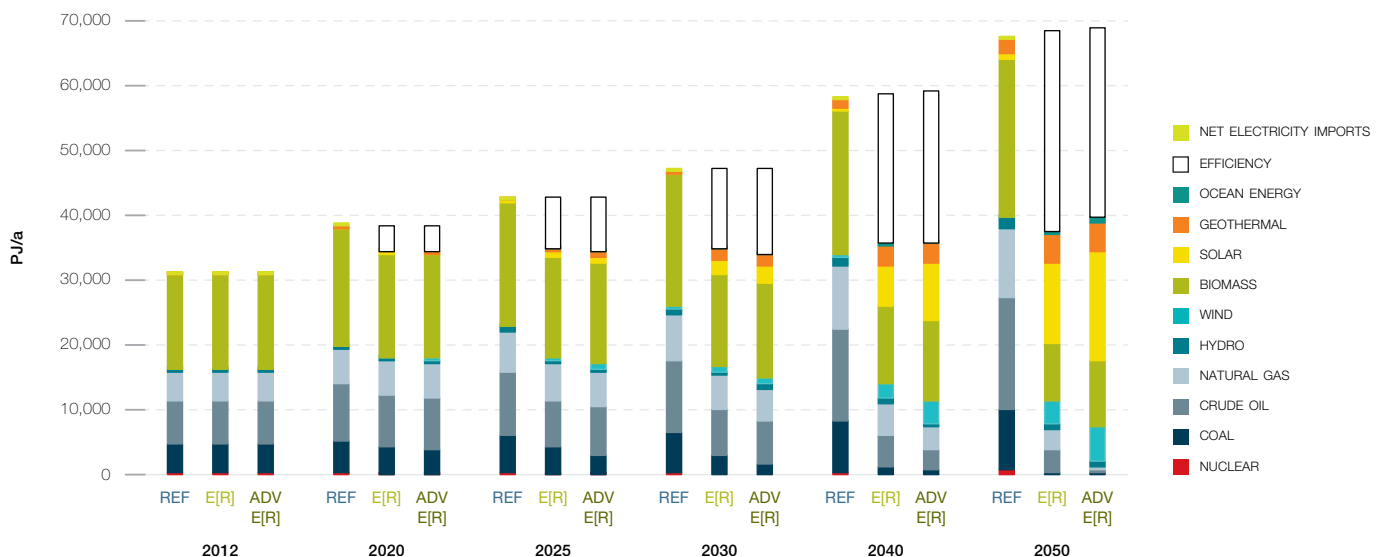
**FIGURE 6.5.13 | AFRICA: DEVELOPMENT OF CO<sub>2</sub> EMISSIONS BY SECTOR UNDER THE ENERGY [R]EVOLUTION SCENARIOS**

'SAVINGS' = REDUCTION COMPARED TO THE REFERENCE SCENARIO



very efficient vehicle concepts in the transport sector to replace oil based combustion engines. This leads to an overall renewable primary energy share of 56% in 2030 and 81% in 2050 in the basic Energy [R]evolution and of more than 97% in 2050 in the Advanced case (incl. non-energy consumption). In contrast to the Reference scenario, no new nuclear power plants will be built in Africa in the Energy [R]evolution scenarios.

**FIGURE 6.5.12 | AFRICA: PROJECTION OF TOTAL PRIMARY ENERGY DEMAND (PED) BY ENERGY CARRIER INCLUDING ELECTRICITY** INCLUDING ELECTRICITY IMPORT BALANCE – REFERENCE, ENERGY [R]EVOLUTION, ADVANCED ENERGY [R]EVOLUTION SCENARIOS



**TABLE 6.5.6 | AFRICA: ACCUMULATED INVESTMENT COSTS FOR ELECTRICITY GENERATION AND FUEL COST SAVINGS UNDER THE ENERGY [R]EVOLUTION SCENARIO COMPARED TO THE REFERENCE SCENARIO**

ACCUMULATED INVESTMENT COSTS DIFFERENCE REF MINUS E[R]	UNIT	2012-2020	2021-2030	2031-2040	2041-2050	2012-2050	2012 - 2050 AVERAGE PER YEAR
CONVENTIONAL (FOSSIL + NUCLEAR)	BILLION \$	31.6	73.7	102.9	123.4	331.5	8.5
RENEWABLES (INCL. CHP)	BILLION \$	-85.8	-514.8	-839.3	-1,116.8	-2,556.6	-65.6
TOTAL	BILLION \$	-54.2	-441.0	-736.4	-993.4	-2,225.1	-57.1
<b>ACCUMULATED FUEL COST SAVINGS</b>							
SAVINGS CUMULATIVE E[R] VERSUS REF							
FUEL OIL	BILLION \$	17.0	88.0	124.9	130.5	360.4	9.2
GAS	BILLION \$	7.6	153.0	477.6	831.7	1,470.0	37.7
HARD COAL	BILLION \$	8.6	87.5	209.6	340.9	646.6	16.6
LIGNITE	BILLION \$	0.0	0.0	0.0	0.0	0.0	0.0
NUCLEAR ENERGY	BILLION \$	0.2	2.6	6.5	12.4	21.7	0.6
TOTAL	BILLION \$	33.3	331.0	818.7	1,315.5	2,498.6	64.1

**TABLE 6.5.7 | ACCUMULATED INVESTMENT COSTS FOR RENEWABLE HEAT GENERATION UNDER THE ENERGY [R]EVOLUTION SCENARIO COMPARED TO THE REFERENCE SCENARIO**

ACCUMULATED INVESTMENT COSTS DIFFERENCE REF MINUS E[R]	UNIT	2012-2020	2021-2030	2031-2040	2041-2050	2012-2050	2012 - 2050 AVERAGE PER YEAR
RENEWABLES	BILLION \$	-156.6	-186.9	81.7	158.1	-103.7	-2.7

**TABLE 6.5.8 | AFRICA: ACCUMULATED INVESTMENT COSTS FOR ELECTRICITY GENERATION AND FUEL COST SAVINGS UNDER THE ADVANCED ENERGY [R]EVOLUTION SCENARIO COMPARED TO THE REFERENCE SCENARIO**

ACCUMULATED INVESTMENT COSTS DIFFERENCE REF MINUS ADVANCED E[R]	UNIT	2012-2020	2021-2030	2031-2040	2041-2050	2012-2050	2012 - 2050 AVERAGE PER YEAR
CONVENTIONAL (FOSSIL + NUCLEAR)	BILLION \$	35.7	82.8	81.8	92.9	293.3	7.5
RENEWABLES (INCL. CHP)	BILLION \$	-103.5	-707.9	-1,450.7	-1,734.6	-3,996.7	-102.5
TOTAL	BILLION \$	-67.7	-625.1	-1,368.9	-1,641.7	-3,703.3	-95.0
<b>ACCUMULATED FUEL COST SAVINGS</b>							
SAVINGS CUMULATIVE ADVANCED E[R] VERSUS REF							
FUEL OIL	BILLION \$	17.0	88.0	124.9	130.5	360.4	9.2
GAS	BILLION \$	7.6	153.0	518.1	921.6	1,600.3	41.0
HARD COAL	BILLION \$	10.5	110.3	226.0	338.9	685.6	17.6
LIGNITE	BILLION \$	0.0	0.0	0.0	0.0	0.0	0.0
NUCLEAR ENERGY	BILLION \$	0.2	2.6	6.5	12.4	21.7	0.6
TOTAL	BILLION \$	35.2	353.9	875.6	1,403.4	2,668.0	68.4

**TABLE 6.5.9 | AFRICA: ACCUMULATED INVESTMENT COSTS FOR RENEWABLE HEAT GENERATION UNDER THE ADVANCED ENERGY [R]EVOLUTION SCENARIO COMPARED TO THE REFERENCE SCENARIO**

ACCUMULATED INVESTMENT COSTS DIFFERENCE REF MINUS ADVANCED E[R]	UNIT	2012-2020	2021-2030	2031-2040	2041-2050	2012-2050	2012 - 2050 AVERAGE PER YEAR
RENEWABLES	BILLION \$	-156.6	-186.9	80.9	152.3	-110.3	-2.8

## 6.6 MIDDLE EAST

### 6.6.1 FINAL ENERGY DEMAND BY SECTOR

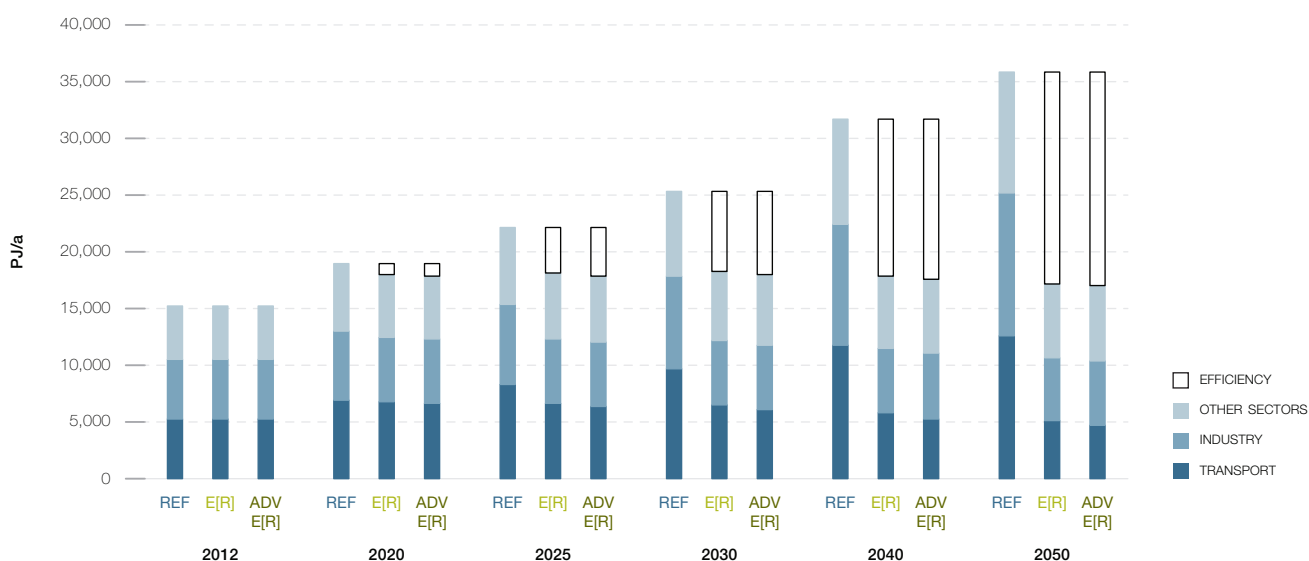
Combining the projections on population development, GDP growth and energy intensity results in future development pathways for Middle East's final energy demand. These are shown in Figure 6.6.1 for the Reference and Energy [R]evolution scenarios. Under the Reference scenario, total final energy demand increases by 134% from the current 15,300 PJ/a to 35,800 PJ/a in 2050. In the basic Energy [R]evolution scenario, final energy demand increases at a much lower rate by 12% compared to current consumption and is expected to reach 17,200 PJ/a by 2050. The Advanced scenario results in some additional reductions due to a higher share of electric cars.

Under both Energy [R]evolution scenarios, due to economic growth, increasing living standards and electrification of the transport sector, overall electricity demand is expected to increase despite efficiency gains in all sectors (see Figure 6.6.2). Total electricity demand will rise from about 730 TWh/a to 2,440 TWh/a by 2050 in the basic Energy [R]evolution scenario. Compared to the Reference scenario, efficiency measures in the industry, residential and service sectors avoid the generation of about 810 TWh/a.

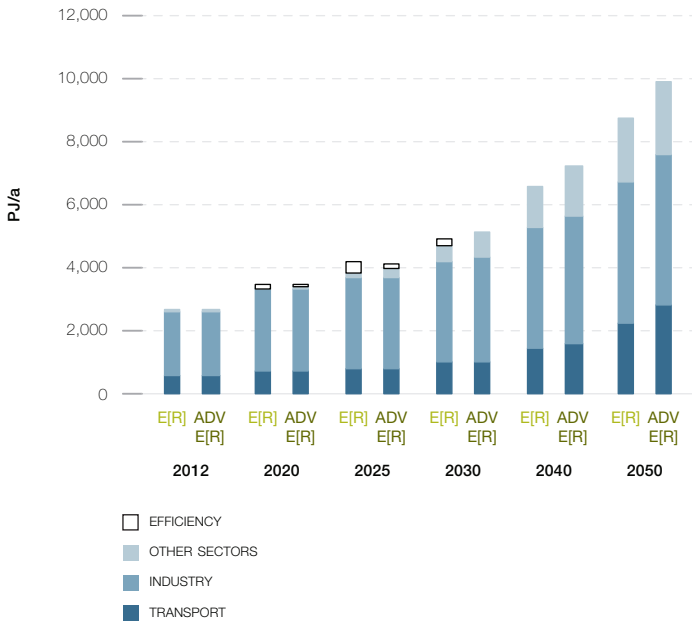
This reduction can be achieved in particular by introducing highly efficient electronic devices using the best available technology in all demand sectors. The transformation to a carbon free energy system in the Advanced scenario will further increase the electricity demand in 2050 up to 2,700 TWh/a. Electricity will become the major renewable 'primary' energy, not only for direct use for various purposes but also for the generation of synthetic fuels for fossil fuels substitution. Around 650 TWh are used in 2050 for electric vehicles and rail transport in 2050 in the Advanced scenario, around 650 TWh for hydrogen and 60 TWh for synthetic liquid fuel generation for the transport sector (excluding bunkers).

Efficiency gains in the heating sector are even larger than in the electricity sector. Under the Energy [R]evolution scenarios, consumption equivalent to about 6,600 PJ/a is avoided through efficiency gains by 2050 compared to the Reference scenario. As a result of the introduction of low energy standards and highly efficient technologies e.g. for industrial and commercial process heat, cooking and air conditioning, enjoyment of the same comfort and energy services will be accompanied by much lower future energy demand.

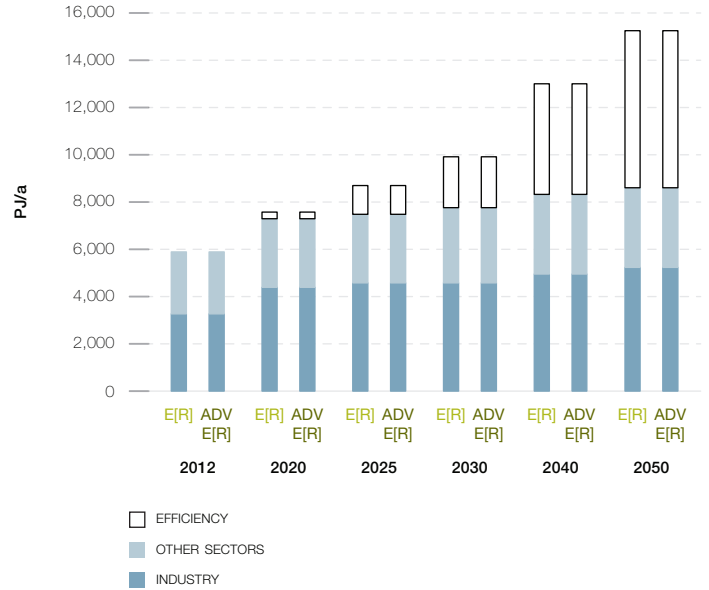
**FIGURE 6.6.1 | MIDDLE EAST: PROJECTION OF TOTAL FINAL ENERGY DEMAND BY SECTOR – REFERENCE, ENERGY [R]EVOLUTION, ADVANCED ENERGY [R]EVOLUTION SCENARIOS** WITHOUT NON-ENERGY USE AND HEAT FROM CHP AUTOPRODUCERS



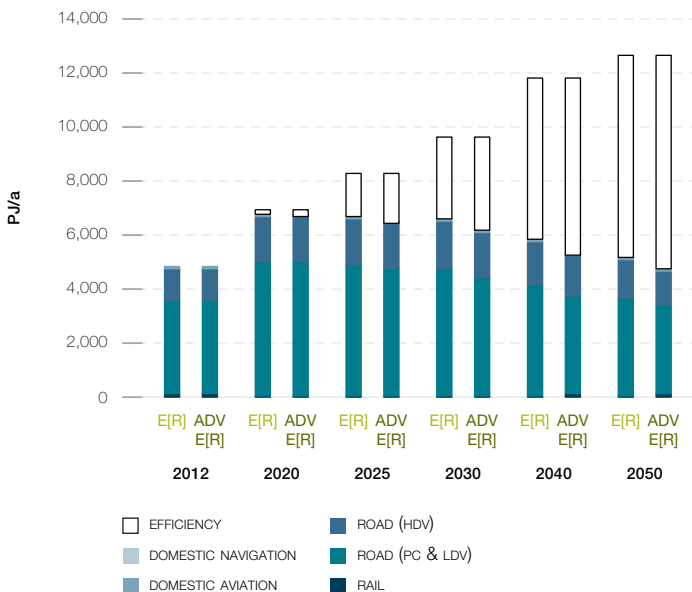
**FIGURE 6.6.2 | MIDDLE EAST: DEVELOPMENT OF ELECTRICITY DEMAND BY SECTOR IN THE ENERGY [R]EVOLUTION SCENARIOS**



**FIGURE 6.6.4 | MIDDLE EAST: DEVELOPMENT OF FINAL ENERGY DEMAND FOR HEAT BY SECTOR IN THE ENERGY [R]EVOLUTION SCENARIOS**



**FIGURE 6.6.3 | MIDDLE EAST: DEVELOPMENT OF THE FINAL ENERGY DEMAND FOR TRANSPORT BY SECTOR IN THE ENERGY [R]EVOLUTION SCENARIOS**



### 6.6.2 ELECTRICITY GENERATION

The development of the electricity supply sector is characterised by a dynamically growing renewable energy market and an increasing share of renewable electricity. This trend will more than compensate for the strong reduction of fossil fuel fired power plants in the Energy [R]evolution scenarios. By 2050, 93% of the electricity produced in Middle East will come from renewable energy sources in the basic Energy [R]evolution scenario. ‘New’ renewables – mainly wind, PV, CSP and geothermal energy – will contribute 86% to the total electricity generation. Already by 2020 the share of renewable electricity production will be 14% and 52% by 2030. The installed capacity of renewables will reach about 360 GW in 2030 and 1,170 GW by 2050.

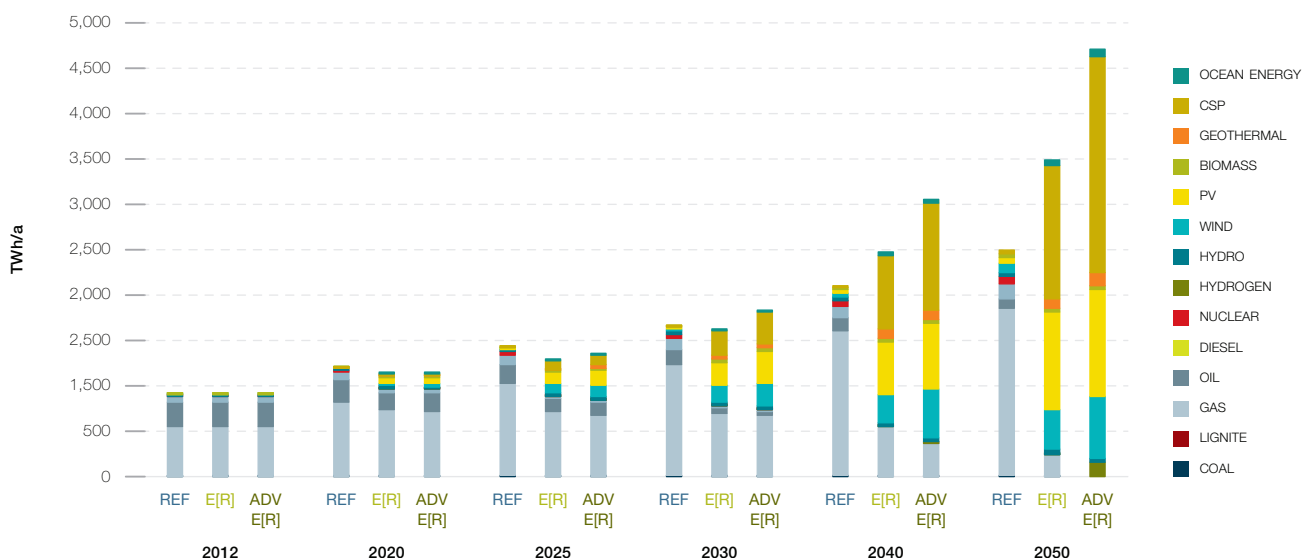
A 100% electricity supply from renewable energy resources in the Advanced scenario leads to around 1,510 GW installed generation capacity in 2050.

Table 6.6.1 shows the comparative evolution of the different renewable technologies in Middle East over time. By 2020 wind and PV overtake hydro, currently the largest contributor to the growing renewable market. After 2020, the continuing growth of wind and PV will be complemented by electricity from solar thermal, geothermal and ocean energy. The Energy [R]evolution scenarios will lead to a high share of fluctuating power generation sources (PV, wind and ocean) of already 28% to 34% by 2030 and 45% to 41% by 2050. Therefore, smart grids, demand side management (DSM), energy storage capacities and other options need to be expanded in order to increase the flexibility of the power system for grid integration, load balancing and a secure supply of electricity.

**TABLE 6.6.1 | MIDDLE EAST: PROJECTION OF RENEWABLE ELECTRICITY GENERATION CAPACITY UNDER THE REFERENCE AND THE ENERGY [R]EVOLUTION SCENARIOS** IN GW

		2012	2020	2030	2040	2050
HYDRO	REF	14	18	23	26	30
	E[R]	14	18	23	26	30
	ADV	14	18	23	26	30
BIOMASS	REF	0	0	1	3	7
	E[R]	0	2	5	7	9
	ADV	0	2	5	6	8
WIND	REF	0	1	5	19	45
	E[R]	0	16	82	130	188
	ADV	0	21	107	229	285
GEOTHERMAL	REF	0	0	0	0	0
	E[R]	0	1	6	14	15
	ADV	0	2	6	14	22
PV	REF	0	3	9	19	35
	E[R]	0	34	151	358	656
	ADV	0	34	223	449	722
CSP	REF	0	2	5	8	7
	E[R]	0	10	86	167	245
	ADV	0	10	109	242	394
OCEAN	REF	0	0	0	0	0
	E[R]	0	2	7	17	26
	ADV	0	2	7	30	46
TOTAL	REF	15	24	44	75	124
	E[R]	15	83	360	719	1,168
	ADV	15	89	480	996	1,505

**FIGURE 6.6.5 | MIDDLE EAST: DEVELOPMENT OF ELECTRICITY GENERATION STRUCTURE – REFERENCE, ENERGY [R]EVOLUTION, ADVANCED ENERGY [R]EVOLUTION SCENARIOS**





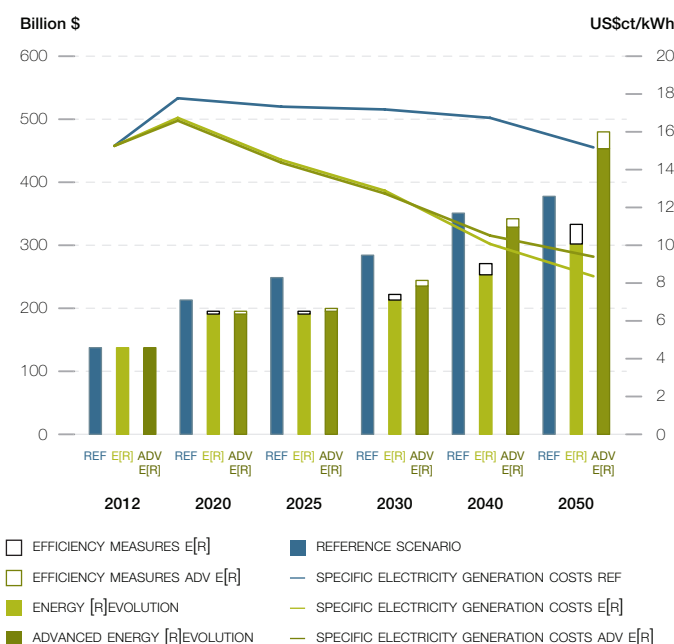
### 6.6.3 FUTURE COSTS OF ELECTRICITY GENERATION

Figure 6.6.6 shows that the introduction of renewable technologies under both Energy [R]evolution scenarios decreases the future costs of electricity generation compared to the Reference scenario by 2030. This difference in full cost of generation will be less than 2.8 US\$ct/kWh in the basic Energy [R]evolution and about 3 US\$ct/kWh in the Advanced scenario, without taking into account integration costs for storage or other load-balancing measures. Because of increasing prices for conventional fuels, electricity generation costs will become economically favourable in the future under the Energy [R]evolution scenarios. By 2050, the cost will be 6.8/5.8 US\$ct/kWh, respectively, below those in the Reference case.

Under the Reference scenario, on the other hand, growth in demand and increasing fossil fuel prices result in total electricity supply costs rising from today's US\$ 138 billion per year to more than US\$ 379 billion in 2050, compared to US\$ 302 billion in the basic Energy [R]evolution and US\$ 453 billion in the Advanced Energy [R]evolution scenario. Figure 6.6.6 shows that both Energy [R]evolution scenarios not only comply with Middle East's CO<sub>2</sub> reduction targets, but also help stabilise energy costs and relieve the economic pressure on society.

Increasing energy efficiency and shifting energy supply to renewables lead to long term costs for electricity supply that are 20% lower in the basic Energy [R]evolution scenario than in the Reference scenario despite a 40% increase in electricity production. The Advanced scenario with 100% renewable power and an increase in power generation of 89% results in supply costs 20% higher than the Reference case.

**FIGURE 6.6.6 | MIDDLE EAST: DEVELOPMENT OF TOTAL ELECTRICITY SUPPLY COSTS & OF SPECIFIC ELECTRICITY GENERATION COSTS IN THE SCENARIOS**



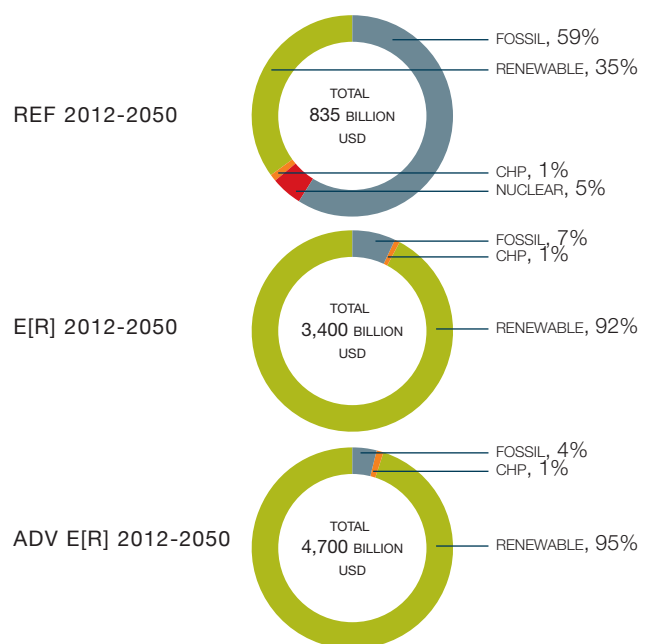
### 6.6.4 FUTURE INVESTMENTS IN THE POWER SECTOR

Around US\$ 3,400 billion is required in investment for the Energy [R]evolution scenario to become reality (including investments for replacement after the economic lifetime of the plants) - approximately US\$ 87 billion per year, US\$ 2,570 billion more than in the Reference scenario (US\$ 835 billion). Investments for the Advanced scenario sum up to US\$ 4,700 billion until 2050, on average US\$ 121 billion per year. Under the Reference scenario, the levels of investment in conventional power plants add up to almost 64% while approximately 36% would be invested in renewable energies and cogeneration until 2050.

Under the Energy [R]evolution scenarios, however, Middle East would shift almost 93%/96% of the entire investment towards renewables and cogeneration, respectively. By 2030, the fossil fuel share of power sector investment would be focused mainly on gas power plants.

Because renewable energy has no fuel costs, the fuel cost savings in the basic Energy [R]evolution scenario reach a total of US\$ 4,270 billion up to 2050, US\$ 109 billion per year. The total fuel cost savings therefore would cover 170% of the total additional investments compared to the Reference scenario. Fuel cost savings in the Advanced scenario are even higher and add up to US\$ 4,570 billion, or US\$ 117 billion per year. Renewable energy sources would then go on to produce electricity without any further fuel costs beyond 2050, while costs for coal and gas will continue to be a burden on national economies.

**FIGURE 6.6.7 | MIDDLE EAST: INVESTMENT SHARES - REFERENCE VERSUS ENERGY [R]EVOLUTION SCENARIOS**



### 6.6.5 ENERGY SUPPLY FOR HEATING

Today, renewables meet around 1% of Middle East's energy demand for heating, the main contribution coming from the use of biomass. Dedicated support instruments are required to ensure a dynamic development in particular for renewable technologies for buildings and renewable process heat production. In the basic Energy [R]evolution scenario, renewables already provide 24% of Middle East's total heat demand in 2030 and 78% in 2050.

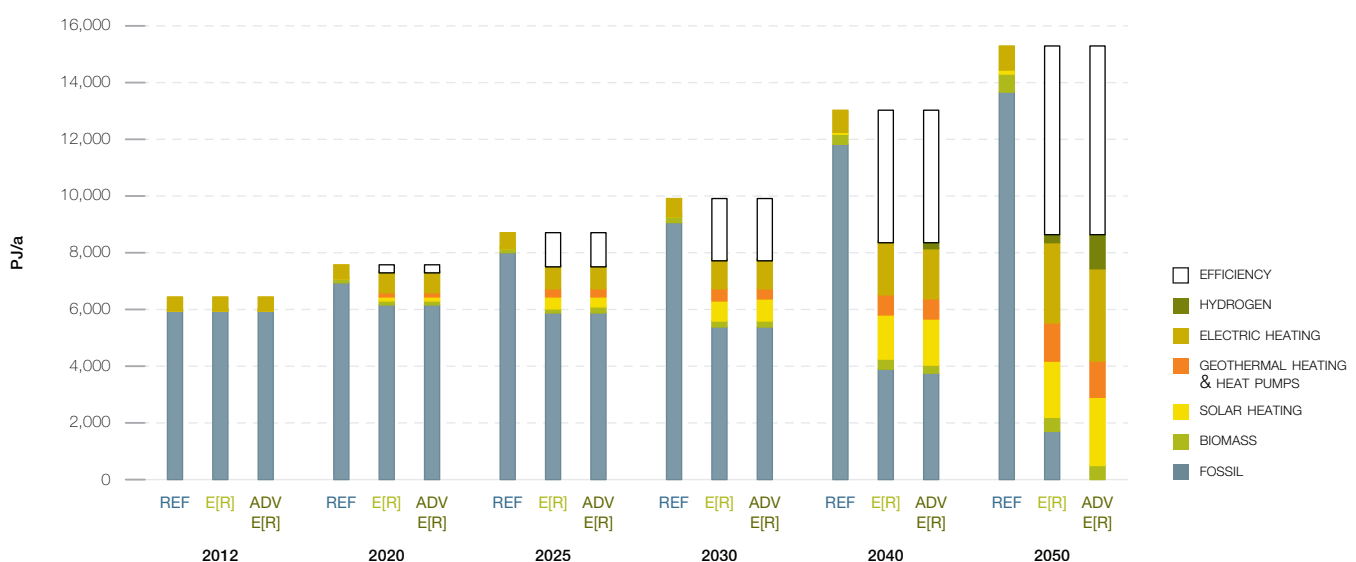
- Energy efficiency measures help to reduce the currently growing energy demand for heating and processes by 43 % in 2050 (relative to the Reference scenario), in spite of improving living standards and economic growth.
- In the industry sector solar collectors, geothermal energy (incl. heat pumps) as well as electricity and hydrogen from renewable sources are increasingly substituting for fossil fuel-fired systems.
- A shift from coal and oil to natural gas in the remaining conventional applications leads to a further reduction of CO<sub>2</sub> emissions.

Table 6.6.2 shows the development of different renewable technologies for heating in Middle East over time. By 2030, the continuing growth of solar collectors and a growing share of geothermal and environmental heat as well as heat from renewable hydrogen will reduce the dependence on fossil fuels. The Advanced scenario results in a complete substitution of the remaining gas consumption by hydrogen generated from renewable electricity.

**TABLE 6.6.2 | MIDDLE EAST: PROJECTION OF RENEWABLE HEAT SUPPLY UNDER THE REFERENCE AND BOTH ENERGY [R]EVOLUTION SCENARIOS** IN PJ/a

		2012	2020	2030	2040	2050
BIOMASS	REF	20	131	188	350	569
	E[R]	20	152	187	302	511
	ADV	20	152	187	302	511
SOLAR HEATING	REF	7	40	55	94	149
	E[R]	7	370	733	1,609	2,020
	ADV	7	370	733	1,609	2,386
GEOTHERMAL HEAT AND HEAT PUMPS	REF	0	0	0	0	0
	E[R]	0	287	383	722	1,287
	ADV	0	287	383	722	1,287
HYDROGEN	REF	0	0	0	0	0
	E[R]	0	3	6	17	312
	ADV	0	3	6	188	1,258
TOTAL	REF	27	171	243	445	719
	E[R]	27	813	1,310	2,649	4,130
	ADV	27	813	1,310	2,820	5,442

**FIGURE 6.6.8 | MIDDLE EAST: PROJECTION OF HEAT SUPPLY BY ENERGY CARRIER – REFERENCE, ENERGY [R]EVOLUTION, ADVANCED ENERGY [R]EVOLUTION SCENARIOS**



### 6.6.6 FUTURE INVESTMENTS IN THE HEATING SECTOR

Also in the heating sector the Energy [R]evolution scenarios would require a major revision of current investment strategies in heating technologies. In particular, solar thermal, geothermal and heat pump technologies need an enormous increase in installations if these potentials are to be tapped for the heating sector. The use of biomass for heating purposes - often traditional biomass today - will be redirected towards new efficient technologies in the Energy [R]evolution scenarios and supplement other sustainable renewable heating technologies.

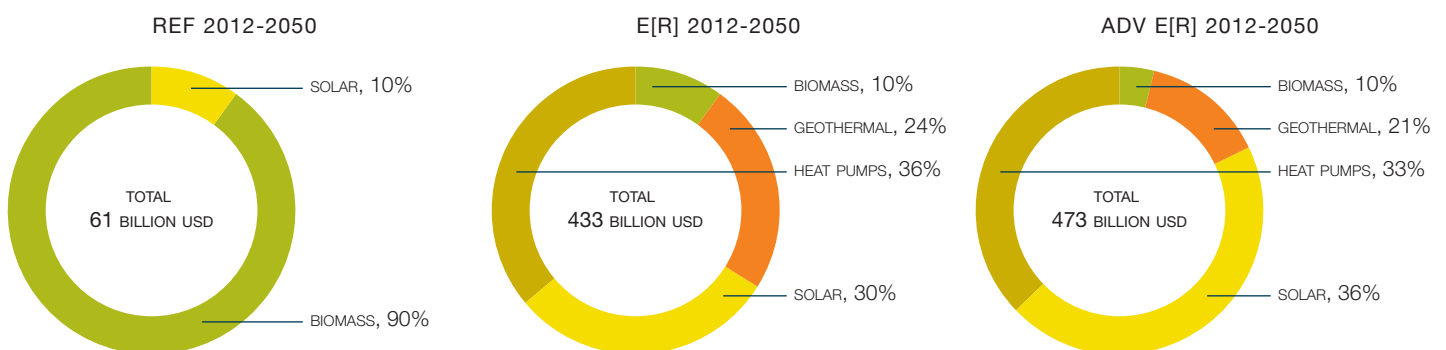
Renewable heating technologies are extremely variable, from low tech biomass stoves and unglazed solar collectors to very sophisticated enhanced geothermal and solar systems. Thus, it can only be roughly estimated that the Energy [R]evolution scenario in total requires around US\$ 430 billion to be invested in renewable heating technologies up to 2050 (including investments for replacement after the economic lifetime of the plants) - approximately US\$ 11 billion per year. The Advanced scenario assumes an equally ambitious expansion of renewable technologies resulting in an average investment of around US\$ 12 billion per year, while the main strategy in the scenario is the substitution of the remaining natural gas amounts with electricity, hydrogen or other synthetic fuels.

**TABLE 6.6.3 | MIDDLE EAST: INSTALLED CAPACITIES FOR RENEWABLE HEAT GENERATION UNDER THE SCENARIOS** IN GW

		2012	2020	2030	2040	2050
BIOMASS	REF	5	12	28	47	70
	E[R]	5	20	26	34	46
	ADV	5	20	26	34	46
GEOTHERMAL	REF	0	0	0	0	0
	E[R]	0	10	17	21	34
	ADV	0	10	17	21	34
SOLAR HEATING	REF	1	5	10	18	28
	E[R]	1	31	117	254	302
	ADV	1	31	117	254	341
HEAT PUMPS	REF	0	0	0	0	0
	E[R]	0	7	16	36	81
	ADV	0	7	16	36	81
TOTAL*	REF	6	17	38	65	98
	E[R]	6	68	176	345	464
	ADV	6	68	176	345	502

\* Excluding direct electric heating.

**FIGURE 6.6.9 | MIDDLE EAST: DEVELOPMENT OF INVESTMENTS FOR RENEWABLE HEAT GENERATION TECHNOLOGIES – REFERENCE, ENERGY [R]EVOLUTION, ADVANCED ENERGY [R]EVOLUTION SCENARIOS**



### 6.6.7 FUTURE EMPLOYMENT IN THE ENERGY SECTOR

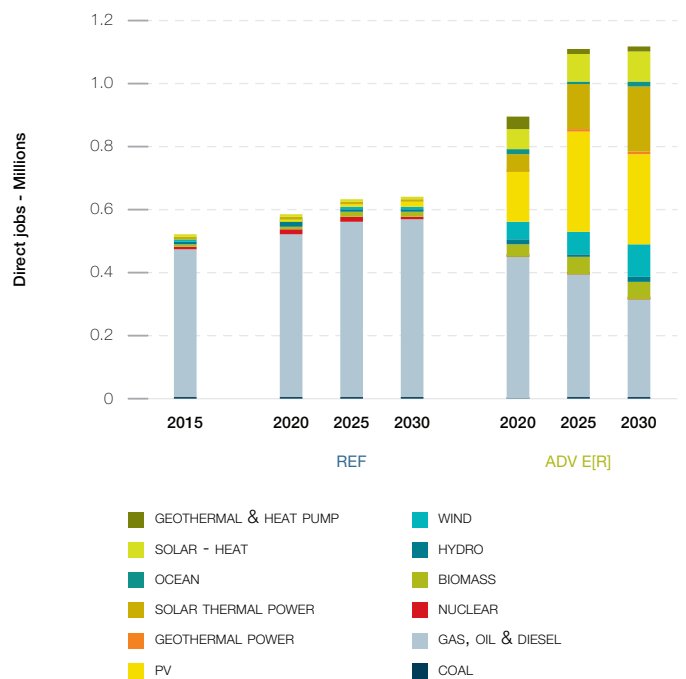
The Advanced Energy [R]evolution scenario results in more energy sector jobs in the Middle East at every stage of the projection.

- There are 0.9 million energy sector jobs in the Advanced Energy [R]evolution in 2020, and 0.6 million in the Reference scenario.
- In 2025, there are 1.1 million jobs in the Advanced Energy [R]evolution scenario, and 0.6 million in the Reference scenario.
- In 2030, there are 1.1 million jobs in the Advanced Energy [R]evolution scenario and 0.6 million in the Reference scenario.

Figure 6.6.10 shows the change in job numbers under both scenarios for each technology between 2015 and 2030. Jobs in the Reference scenario increase gradually to 24% above 2015 levels by 2030. Gas accounts for 88% of energy sector jobs in this scenario.

Growth in renewable energy leads to an increase of 73% in total energy sector jobs in the Advanced Energy [R]evolution scenario by 2020, and compensates for a strong decline in gas jobs. Jobs remain stable after 2025, and are 116% above 2015 levels in 2030. Renewable energy accounts for 71% of energy jobs at 2030, with PV having the greatest share.

**FIGURE 6.6.10 | MIDDLE EAST: EMPLOYMENT IN THE ENERGY SECTOR UNDER THE REFERENCE AND ADVANCED ENERGY [R]EVOLUTION SCENARIO**



**TABLE 6.6.4 | MIDDLE EAST: TOTAL EMPLOYMENT IN THE ENERGY SECTOR IN THOUSAND JOBS**

	2015	2020	REFERENCE		ENERGY [R]EVOLUTION		
			2025	2030	2020	2025	2030
COAL	3	2	2	2	1	1	1
GAS, OIL & DIESEL	473	523	563	564	451	394	317
NUCLEAR	8	11	10	9	0	0	0
RENEWABLES	31	45	56	63	442	716	797
<b>TOTAL JOBS</b>	<b>516</b>	<b>581</b>	<b>632</b>	<b>638</b>	<b>894</b>	<b>1,112</b>	<b>1,116</b>
CONSTRUCTION AND INSTALLATION	40	45	43	36	283	449	413
MANUFACTURING	18	18	17	13	79	101	96
OPERATIONS AND MAINTENANCE	63	76	85	87	110	181	284
FUEL SUPPLY (DOMESTIC)	338	384	422	436	360.3	335	293
COAL AND GAS EXPORT	57	59	65	66	61	46	31
<b>TOTAL JOBS</b>	<b>516</b>	<b>581</b>	<b>632</b>	<b>638</b>	<b>894</b>	<b>1,112</b>	<b>1,116</b>

### 6.6.8 TRANSPORT

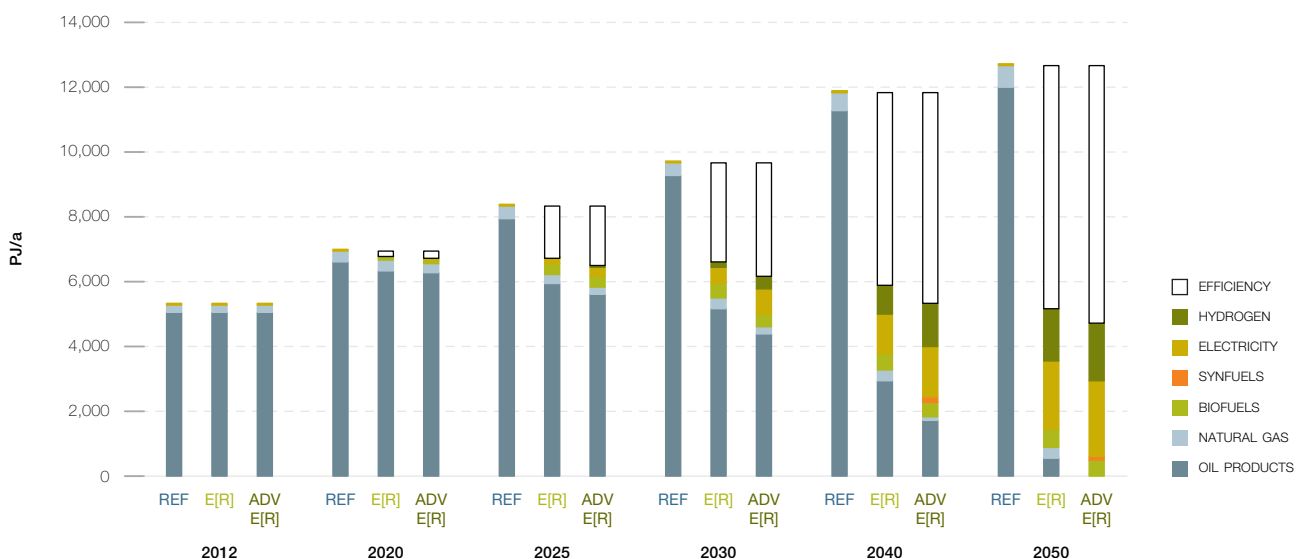
A key target in Middle East is to introduce incentives for people to drive smaller cars and buy new, more efficient vehicle concepts. In addition, it is vital to shift transport use to efficient modes like rail, light rail and buses, especially in the expanding urban areas. Along with rising prices for fossil fuels, these changes reduce the further growth in car sales projected under the Reference scenario. Due to population increase, GDP growth and higher living standards, energy demand from the transport sector is expected to increase in the Reference scenario by around 140% to 12,680 PJ/a in 2050. In the basic Energy [R]evolution scenario, efficiency measures and modal shifts will save 59% (7,530 PJ/a) in 2050 compared to the Reference scenario.

Additional modal shifts and technology switches lead to even higher energy savings in the Advanced scenario of 63% (7,950 PJ/a) in 2050 compared to the Reference scenario. Highly efficient propulsion technology with hybrid, plug-in hybrid and battery-electric power trains will bring about large efficiency gains. By 2030, electricity will provide 8% of the transport sector's total energy demand in the Energy [R]evolution, while in 2050 the share will be 40% (49% in the Advanced scenario). Hydrogen and other synthetic fuels generated using renewable electricity are complementary options to further increase the renewable share in the transport sector. In 2050, up to 1,810 PJ/a of hydrogen is used in the transport sector for the Advanced Energy [R]evolution scenario.

**TABLE 6.6.5 | MIDDLE EAST: PROJECTION OF TRANSPORT ENERGY DEMAND BY MODE IN THE REFERENCE AND THE ENERGY [R]EVOLUTION SCENARIOS** IN PJ/a

		2012	2020	2030	2040	2050
RAIL	REF	2	2	2	2	2
	E[R]	2	3	4	3	5
	ADV	2	20	60	88	89
ROAD	REF	5,226	8,197	9,565	11,673	12,486
	E[R]	5,226	6,717	6,515	5,787	5,053
	ADV	5,226	6,642	6,031	5,126	4,550
DOMESTIC AVIATION	REF	46	76	84	116	154
	E[R]	46	53	65	80	85
	ADV	46	53	65	80	85
DOMESTIC NAVIGATION	REF	0	0	0	0	0
	E[R]	0	0	0	0	0
	ADV	0	0	0	0	0
TOTAL	REF	5,275	8,276	9,651	11,792	12,642
	E[R]	5,275	6,773	6,583	5,871	5,142
	ADV	5,275	6,716	6,156	5,295	4,724

**FIGURE 6.6.11 | MIDDLE EAST: FINAL ENERGY CONSUMPTION IN TRANSPORT UNDER THE SCENARIOS**



### 6.6.10 DEVELOPMENT OF CO<sub>2</sub> EMISSIONS

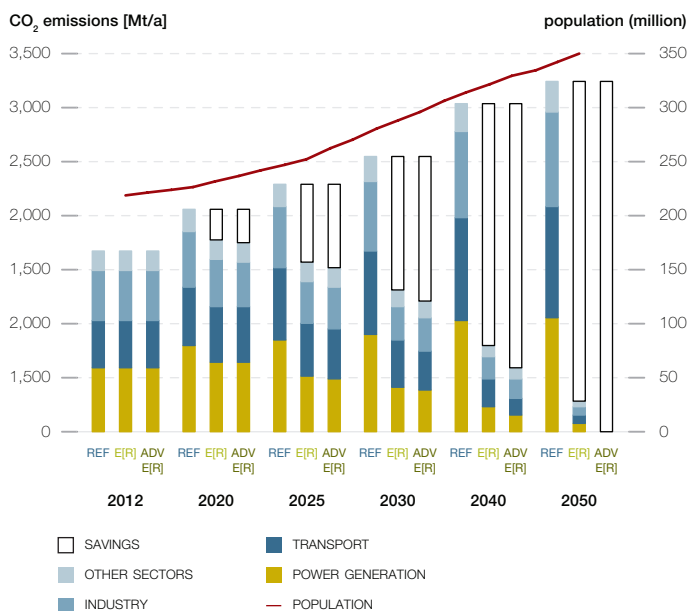
Whilst Middle East's emissions of CO<sub>2</sub> will double between 2012 and 2050 under the Reference scenario, under the Energy [R]evolution scenario they will decrease from 1,670 million tonnes in 2012 to 294 million tonnes in 2050. Annual per capita emissions will drop from 7.7 tonne to 0.8 tonne. In spite of the abstinence of nuclear power production and increasing power demand, CO<sub>2</sub> emissions will decrease in the electricity sector. In the long run efficiency gains and the increased use of renewable electricity in vehicles strongly reduce emissions in the transport sector as well. With a 32% share of CO<sub>2</sub>, the Power generation sector will be the largest source of emissions in 2050 in the basic Energy [R]evolution scenario. By 2050, Middle East's CO<sub>2</sub> emissions are 47% below 1990 levels in the Energy [R]evolution scenario while energy consumption is fully decarbonised in the Advanced case.

### 6.6.11 PRIMARY ENERGY CONSUMPTION

Taking into account the assumptions discussed above, the resulting primary energy consumption under the Energy [R]evolution scenarios is shown in Figure 6.6.12. Under the basic Energy [R]evolution scenario, primary energy demand will decrease by 8% from today's 28,270 PJ/a to around 26,000 PJ/a. Compared to the Reference scenario, overall primary energy demand will be reduced by 55% in 2050 under the Energy [R]evolution scenario (Reference scenario: around 58,000 PJ in 2050). Due to additional conversion losses, the Advanced scenario results in a primary energy consumption of around 27,300 PJ in 2050.

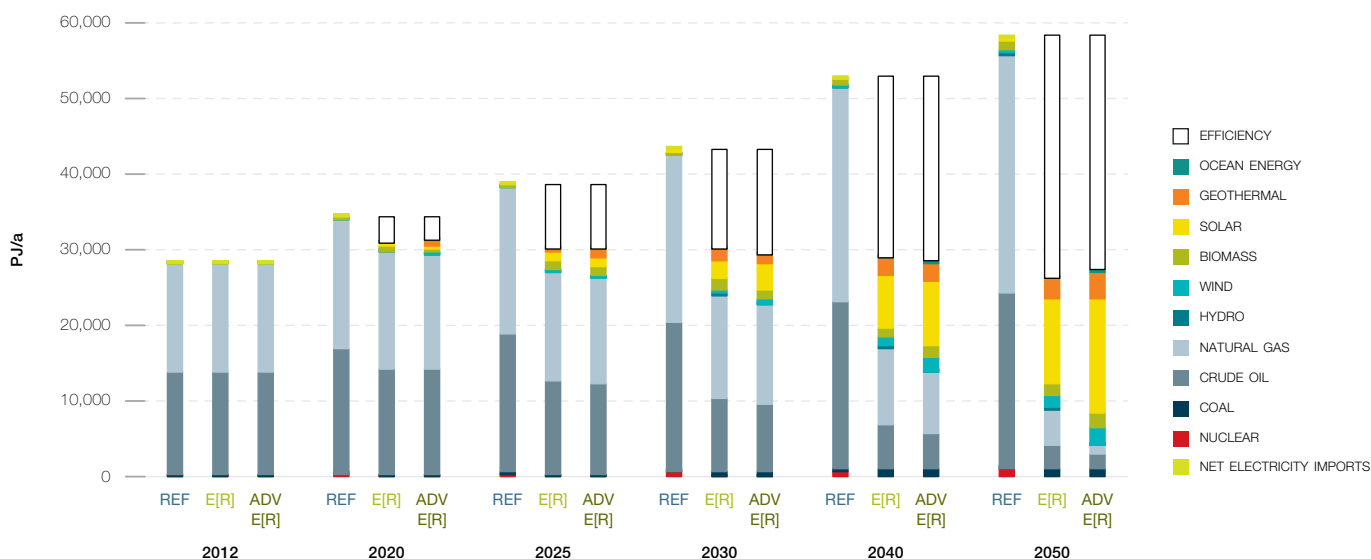
The Energy [R]evolution scenarios aim to phase out coal and oil as fast as technically and economically possible by expansion of renewable energies and a fast introduction of

**FIGURE 6.6.13 | MIDDLE EAST: DEVELOPMENT OF CO<sub>2</sub> EMISSIONS BY SECTOR UNDER THE ENERGY [R]EVOLUTION SCENARIOS** 'SAVINGS' = REDUCTION COMPARED TO THE REFERENCE SCENARIO



very efficient vehicle concepts in the transport sector to replace oil based combustion engines. This leads to an overall renewable primary energy share of 20% in 2030 and 66% in 2050 in the basic Energy [R]evolution and of more than 85% in 2050 in the Advanced case (incl. non-energy consumption). In contrast to the Reference scenario, no new nuclear power plants will be built in Middle East in the Energy [R]evolution scenarios.

**FIGURE 6.6.12 | MIDDLE EAST: PROJECTION OF TOTAL PRIMARY ENERGY DEMAND (PED) BY ENERGY CARRIER INCLUDING ELECTRICITY** INCLUDING ELECTRICITY IMPORT BALANCE – REFERENCE, ENERGY [R]EVOLUTION, ADVANCED ENERGY [R]EVOLUTION SCENARIOS



**TABLE 6.6.6 | MIDDLE EAST: ACCUMULATED INVESTMENT COSTS FOR ELECTRICITY GENERATION AND FUEL COST SAVINGS UNDER THE ENERGY [R]EVOLUTION SCENARIO COMPARED TO THE REFERENCE SCENARIO**

ACCUMULATED INVESTMENT COSTS DIFFERENCE REF MINUS E[R]	UNIT	2012-2020	2021-2030	2031-2040	2041-2050	2012-2050	2012 - 2050 AVERAGE PER YEAR
CONVENTIONAL (FOSSIL + NUCLEAR)	BILLION \$	37.0	90.2	63.1	113.2	303.5	7.8
RENEWABLES (INCL. CHP)	BILLION \$	-152.2	-759.0	-849.3	-1,115.2	-2,875.7	-73.7
<b>TOTAL</b>	<b>BILLION \$</b>	<b>-115.2</b>	<b>-668.8</b>	<b>-786.1</b>	<b>-1,002.1</b>	<b>-2,572.2</b>	<b>-66.0</b>
<b>ACCUMULATED FUEL COST SAVINGS</b>							
SAVINGS CUMULATIVE E[R] VERSUS REF							
FUEL OIL	BILLION \$	46.6	251.7	360.1	303.3	961.6	24.7
GAS	BILLION \$	26.8	432.3	1,120.1	1,683.5	3,262.7	83.7
HARD COAL	BILLION \$	0.7	2.5	3.7	5.0	11.9	0.3
LIGNITE	BILLION \$	0	0	0	0	0	0
NUCLEAR ENERGY	BILLION \$	0.7	5.6	11.4	17.2	34.9	0.9
<b>TOTAL</b>	<b>BILLION \$</b>	<b>74.8</b>	<b>692.0</b>	<b>1,495.2</b>	<b>2,009.0</b>	<b>4,271.1</b>	<b>109.5</b>

**TABLE 6.6.7 | MIDDLE EAST: ACCUMULATED INVESTMENT COSTS FOR RENEWABLE HEAT GENERATION UNDER THE ENERGY [R]EVOLUTION SCENARIO COMPARED TO THE REFERENCE SCENARIO**

ACCUMULATED INVESTMENT COSTS DIFFERENCE REF MINUS E[R]	UNIT	2012-2020	2021-2030	2031-2040	2041-2050	2012-2050	2012 - 2050 AVERAGE PER YEAR
RENEWABLES	BILLION \$	59.7	60.3	120.7	131.3	372.0	9.5

**TABLE 6.6.8 | MIDDLE EAST: ACCUMULATED INVESTMENT COSTS FOR ELECTRICITY GENERATION AND FUEL COST SAVINGS UNDER THE ADVANCED ENERGY [R]EVOLUTION SCENARIO COMPARED TO THE REFERENCE SCENARIO**

ACCUMULATED INVESTMENT COSTS DIFFERENCE REF MINUS ADVANCED E[R]	UNIT	2012-2020	2021-2030	2031-2040	2041-2050	2012-2050	2012 - 2050 AVERAGE PER YEAR
CONVENTIONAL (FOSSIL + NUCLEAR)	BILLION \$	38.6	78.8	69.3	153.3	340.0	8.7
RENEWABLES (INCL. CHP)	BILLION \$	-173.5	-1,015.4	-1,337.8	-1,684.6	-4,211.2	-108.0
<b>TOTAL</b>	<b>BILLION \$</b>	<b>-134.9</b>	<b>-936.6</b>	<b>-1,268.5</b>	<b>-1,531.3</b>	<b>-3,871.2</b>	<b>-99.3</b>
<b>ACCUMULATED FUEL COST SAVINGS</b>							
SAVINGS CUMULATIVE ADVANCED E[R] VERSUS REF							
FUEL OIL	BILLION \$	46.6	257.6	373.9	307.4	985.4	25.3
GAS	BILLION \$	29.9	466.2	1,210.8	1,830.9	3,537.8	90.7
HARD COAL	BILLION \$	0.7	2.6	3.7	5.0	12.0	0.3
LIGNITE	BILLION \$	0	0	0	0	0	0
NUCLEAR ENERGY	BILLION \$	0.7	5.6	11.4	17.2	34.9	0.9
<b>TOTAL</b>	<b>BILLION \$</b>	<b>77.8</b>	<b>732.0</b>	<b>1,599.8</b>	<b>2,160.5</b>	<b>4,570.2</b>	<b>117.2</b>

**TABLE 6.6.9 | MIDDLE EAST: ACCUMULATED INVESTMENT COSTS FOR RENEWABLE HEAT GENERATION UNDER THE ADVANCED ENERGY [R]EVOLUTION SCENARIO COMPARED TO THE REFERENCE SCENARIO**

ACCUMULATED INVESTMENT COSTS DIFFERENCE REF MINUS ADVANCED E[R]	UNIT	2012-2020	2021-2030	2031-2040	2041-2050	2012-2050	2012 - 2050 AVERAGE PER YEAR
RENEWABLES	BILLION \$	59.7	60.3	120.7	171.1	411.8	10.6

## 6.7 EASTERN EUROPE/EURASIA

### 6.7.1 FINAL ENERGY DEMAND BY SECTOR

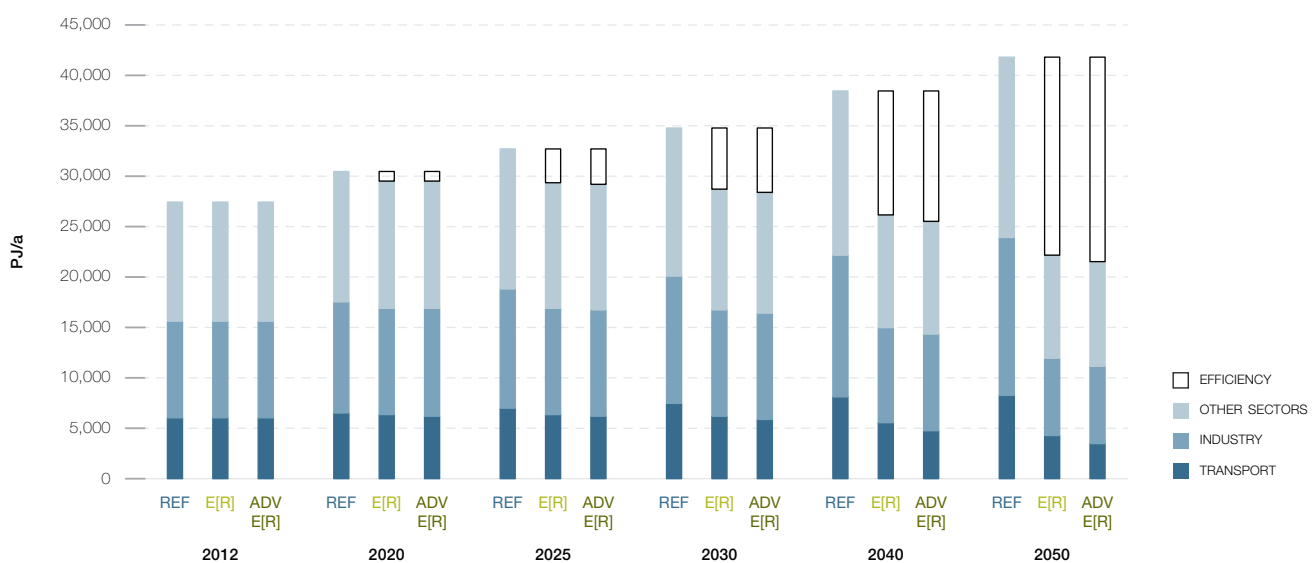
Combining the projections on population development, GDP growth and energy intensity results in future development pathways for Eastern Europe/Eurasia's final energy demand. These are shown in Figure 6.7.1 for the Reference and Energy [R]evolution scenarios. Under the Reference scenario, total final energy demand increases by 53% from the current 27,400 PJ/a to 41,800 PJ/a in 2050. In the basic Energy [R]evolution scenario, final energy demand decreases by 19% compared to current consumption and is expected to reach 22,100 PJ/a by 2050. The Advanced scenario results in some additional reductions due to a higher share of electric cars.

Under both Energy [R]evolution scenarios, due to economic growth, increasing living standards and electrification of the transport sector, overall electricity demand is expected to increase despite efficiency gains in all sectors (see Figure 6.7.2). Total electricity demand will rise from about 1,250 TWh/a to 2,360 TWh/a by 2050 in the basic Energy [R]evolution scenario. Compared to the Reference scenario, efficiency measures in the industry, residential and service sectors avoid the generation of about 870 TWh/a.

This reduction can be achieved in particular by introducing highly efficient electronic devices using the best available technology in all demand sectors. The transformation to a carbon free energy system in the Advanced scenario will further increase the electricity demand in 2050 up to 2,500 TWh/a. Electricity will become the major renewable 'primary' energy, not only for direct use for various purposes but also for the generation of synthetic fuels for fossil fuels substitution. Around 580 TWh are used in 2050 for electric vehicles and rail transport in 2050 in the Advanced scenario, around 170 TWh for hydrogen and 150 TWh for synthetic liquid fuel generation for the transport sector (excluding bunkers).

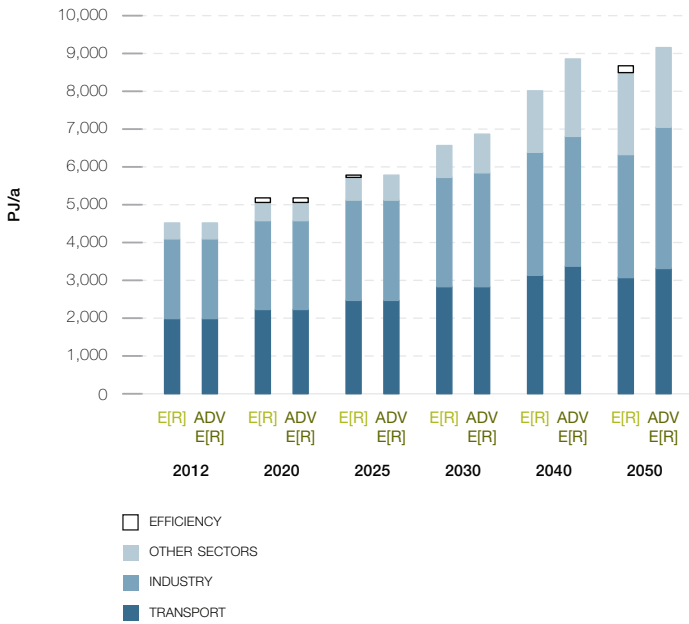
Efficiency gains in the heating sector are even larger than in the electricity sector. Under the Energy [R]evolution scenarios, consumption equivalent to about 11,700 PJ/a is avoided through efficiency gains by 2050 compared to the Reference scenario. As a result of energy-related renovation of the existing stock of residential buildings, the introduction of low energy standards and 'passive climatisation' for new buildings, as well as highly efficient air conditioning systems, enjoyment of the same comfort and energy services will be accompanied with much lower future energy demand.

**FIGURE 6.7.1 | EASTERN EUROPE/EURASIA: PROJECTION OF TOTAL FINAL ENERGY DEMAND BY SECTOR – REFERENCE, ENERGY [R]EVOLUTION, ADVANCED ENERGY [R]EVOLUTION SCENARIOS** WITHOUT NON-ENERGY USE AND HEAT FROM CHP AUTOPRODUCERS

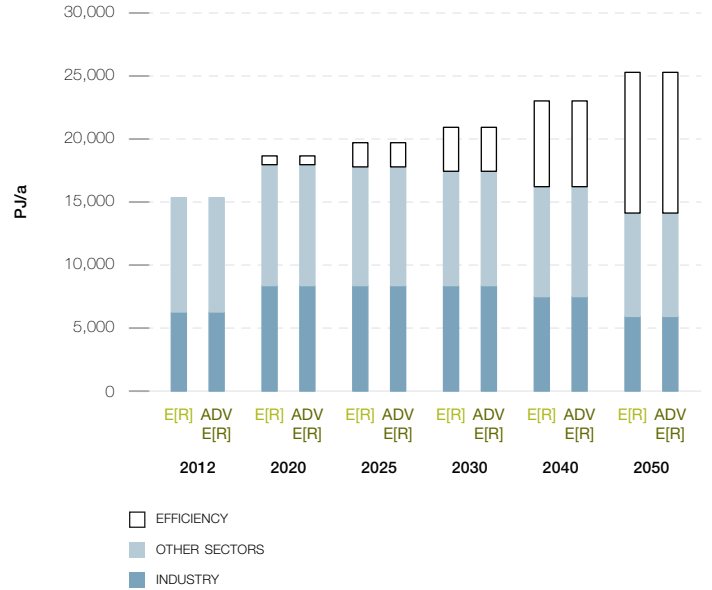




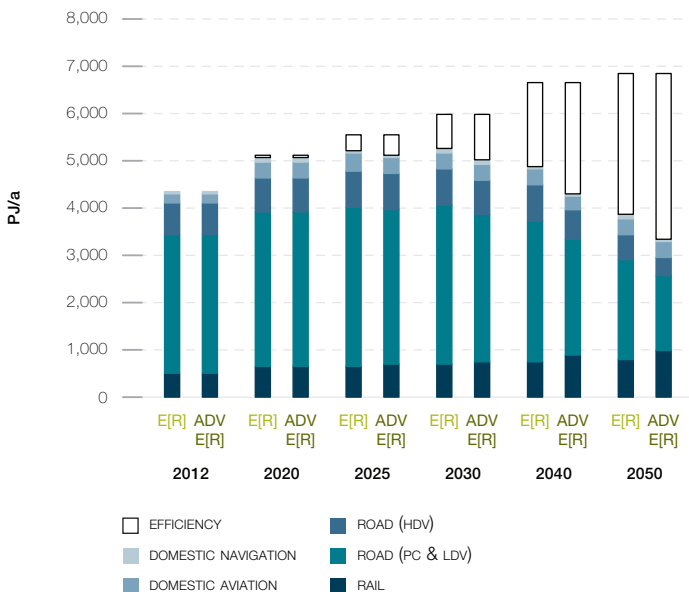
**FIGURE 6.7.2 | EASTERN EUROPE/EURASIA:DEVELOPMENT OF ELECTRICITY DEMAND BY SECTOR IN THE ENERGY [R]EVOLUTION SCENARIOS**



**FIGURE 6.7.4 | EASTERN EUROPE/EURASIA:DEVELOPMENT OF FINAL ENERGY DEMAND FOR HEAT BY SECTOR IN THE ENERGY [R]EVOLUTION SCENARIOS**



**FIGURE 6.7.3 | EASTERN EUROPE/EURASIA:DEVELOPMENT OF THE FINAL ENERGY DEMAND FOR TRANSPORT BY SECTOR IN THE ENERGY [R]EVOLUTION SCENARIOS**



### 6.7.2 ELECTRICITY GENERATION

The development of the electricity supply sector is characterised by a dynamically growing renewable energy market and an increasing share of renewable electricity. This trend will more than compensate for the phasing out of nuclear power production in the Energy [R]evolution scenarios, continuously reducing the number of fossil fuel-fired power plants as well. By 2050, 86% of the electricity produced in Eastern Europe/Eurasia will come from renewable energy sources in the basic Energy [R]evolution scenario. ‘New’ renewables – mainly wind, PV, CSP and geothermal energy – will contribute 51% to the total electricity generation. Already by 2020 the share of renewable electricity production will be 23% and 49% by 2030. The installed capacity of renewables will reach about 460 GW in 2030 and 1,120 GW by 2050.

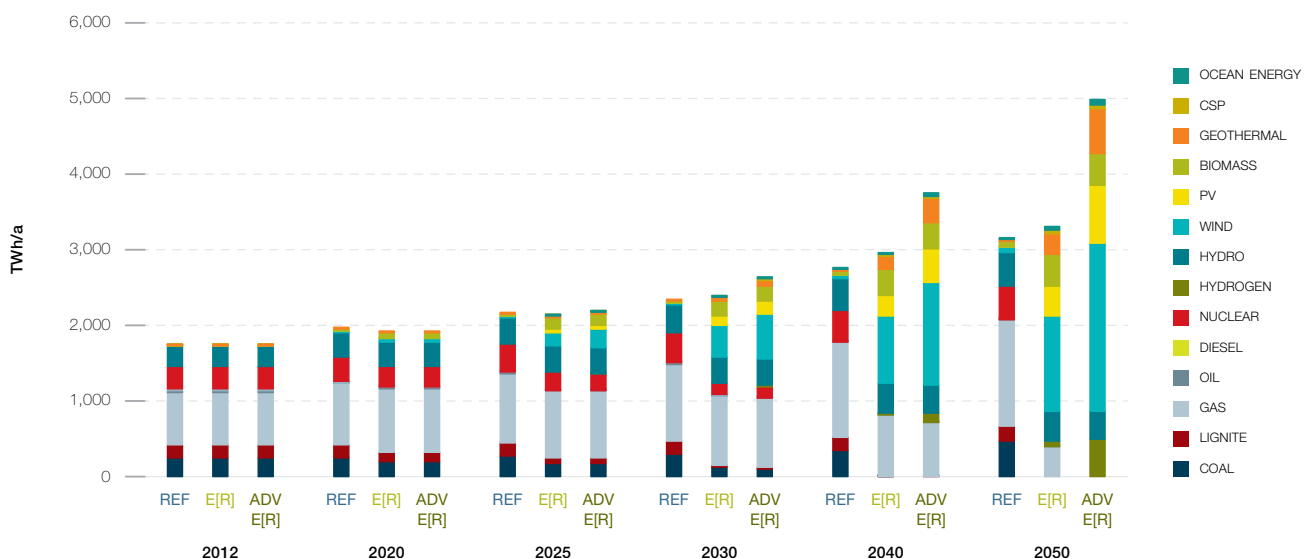
A 100% electricity supply from renewable energy resources in the Advanced scenario leads to around 1,790 GW installed generation capacity in 2050.

Table 6.7.1 shows the comparative evolution of the different renewable technologies in Eastern Europe/Eurasia over time. Up to 2020 wind, biomass and PV will become the main contributors to the growing market share. After 2020, the continuing growth of wind, biomass and PV will be complemented by electricity from solar thermal, geothermal and ocean energy. The Energy [R]evolution scenarios will lead to a high share of fluctuating power generation sources (PV, wind and ocean) of already 23% to 29% by 2030 and 52% to 61% by 2050. Therefore, smart grids, demand side management (DSM), energy storage capacities and other options need to be expanded in order to increase the flexibility of the power system for grid integration, load balancing and a secure supply of electricity.

**TABLE 6.7.1 | EASTERN EUROPE/EURASIA: PROJECTION OF RENEWABLE ELECTRICITY GENERATION CAPACITY UNDER THE REFERENCE AND THE ENERGY [R]EVOLUTION SCENARIOS IN GW**

		2012	2020	2030	2040	2050
HYDRO	REF	93	103	114	125	139
	E[R]	93	103	111	114	115
	ADV	93	103	111	114	115
BIOMASS	REF	1	3	5	9	13
	E[R]	1	16	39	67	90
	ADV	1	16	39	67	91
WIND	REF	4	8	13	20	27
	E[R]	4	18	187	370	506
	ADV	4	19	252	542	869
GEOTHERMAL	REF	0	0	1	2	3
	E[R]	0	1	8	26	40
	ADV	0	1	13	44	81
PV	REF	1	4	6	7	9
	E[R]	1	7	107	246	342
	ADV	1	7	157	399	600
CSP	REF	0	0	0	0	0
	E[R]	0	0	1	5	8
	ADV	0	0	2	10	12
OCEAN	REF	0	0	0	0	0
	E[R]	0	0	2	11	18
	ADV	0	0	3	16	25
TOTAL	REF	99	119	139	164	191
	E[R]	99	145	457	839	1,119
	ADV	99	145	578	1,190	1,793

**FIGURE 6.7.5 | EASTERN EUROPE/EURASIA: DEVELOPMENT OF ELECTRICITY GENERATION STRUCTURE – REFERENCE, ENERGY [R]EVOLUTION, ADVANCED ENERGY [R]EVOLUTION SCENARIOS**



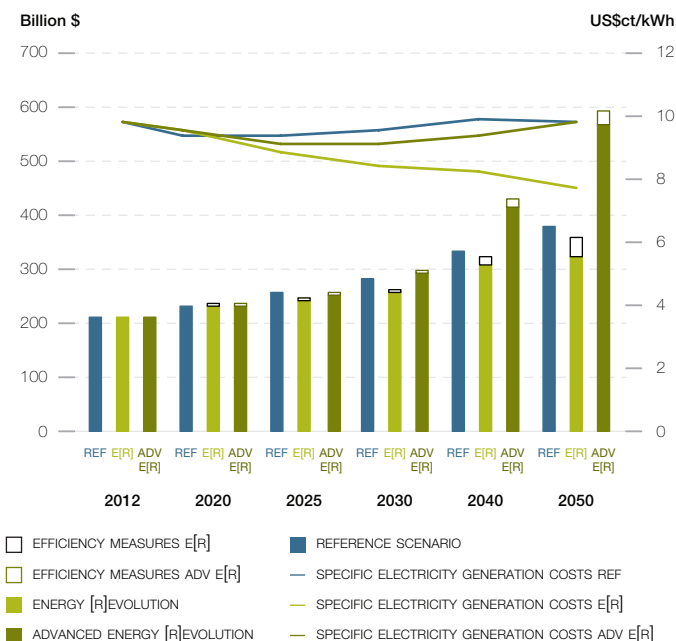
### 6.7.3 FUTURE COSTS OF ELECTRICITY GENERATION

Figure 6.7.6 shows that the introduction of renewable technologies under both Energy [R]evolution scenarios increases the future costs of electricity generation compared to the Reference scenario until 2020. This difference in full cost of generation will be less than 0.2 US\$ct/kWh in both Energy [R]evolution scenarios, without taking into account integration costs for storage or other load-balancing measures. Because of increasing prices for conventional fuels, electricity generation costs will become economically favourable before 2030 under the Energy [R]evolution scenarios. By 2050, the cost in the basic Energy [R]evolution scenario will be 2.2 US\$ct/kWh below those in the Reference case, in the Advanced scenario the cost will be equal to the Reference case.

Under the Reference scenario, on the other hand, growth in demand and increasing fossil fuel prices result in total electricity supply costs rising from today's US\$ 212 billion per year to more than US\$ 379 billion in 2050, compared to US\$ 326 billion in the basic and US\$ 566 billion in the Advanced Energy [R]evolution scenario. Figure 6.7.6 shows that both Energy [R]evolution scenarios not only comply with Eastern Europe/Eurasia's CO<sub>2</sub> reduction targets, but also help stabilise energy costs and relieve the economic pressure on society.

Increasing energy efficiency and shifting energy supply to renewables lead to long term costs for electricity supply that are 14% lower in the basic Energy [R]evolution scenario than in the Reference scenario despite a 5% increase in electricity production. The Advanced scenario with 100% renewable power and an increase in power generation of 58% results in supply costs 49% higher than the Reference case.

**FIGURE 6.7.6 | EASTERN EUROPE/EURASIA: DEVELOPMENT OF TOTAL ELECTRICITY SUPPLY COSTS & OF SPECIFIC ELECTRICITY GENERATION COSTS IN THE SCENARIOS**



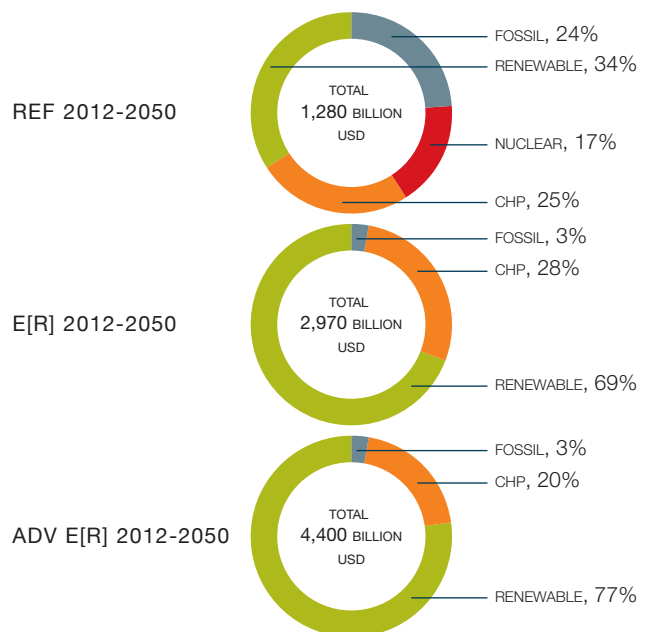
### 6.7.4 FUTURE INVESTMENTS IN THE POWER SECTOR

Around US\$ 2,970 billion is required in investment for the Energy [R]evolution scenario to become reality (including investments for replacement after the economic lifetime of the plants) - approximately US\$ 76 billion per year, US\$ 1,690 billion more than in the Reference scenario (US\$ 1,280 billion). Investments for the Advanced scenario add up to US\$ 4,390 billion until 2050, on average US\$ 113 billion per year, including high investments in additional power plants for the production of synthetic fuels. Under the Reference scenario, the levels of investment in conventional power plants add up to almost 41% while approximately 59% would be invested in renewable energies and cogeneration until 2050.

Under the Energy [R]evolution scenarios, however, Eastern Europe/Eurasia would shift almost 97% of the entire investment towards renewables and cogeneration. By 2030, the fossil fuel share of power sector investment would be focused mainly on gas power plants.

Because renewable energy has no fuel costs, the fuel cost savings in the basic Energy [R]evolution scenario reach a total of US\$ 3,280 billion up to 2050, US\$ 84 billion per year. The total fuel cost savings therefore would cover 190% of the total additional investments compared to the Reference scenario. Fuel cost savings in the Advanced scenario are even higher and add up to US\$ 3,540 billion, or US\$ 91 billion per year. Renewable energy sources would then go on to produce electricity without any further fuel costs beyond 2050, while costs for coal and gas will continue to be a burden on national economies.

**FIGURE 6.7.7 | EASTERN EUROPE/EURASIA: INVESTMENT SHARES - REFERENCE VERSUS ENERGY [R]EVOLUTION SCENARIOS**



### 6.7.5 ENERGY SUPPLY FOR HEATING

Today, renewables meet around 4% of Eastern Europe/Eurasia's energy demand for heating, the main contribution coming from the use of biomass. Dedicated support instruments are required to ensure a dynamic development in particular for renewable technologies for buildings and renewable process heat production. In the basic Energy [R]evolution scenario, renewables already provide 29% of Eastern Europe/Eurasia's total heat demand in 2030 and 86% in 2050.

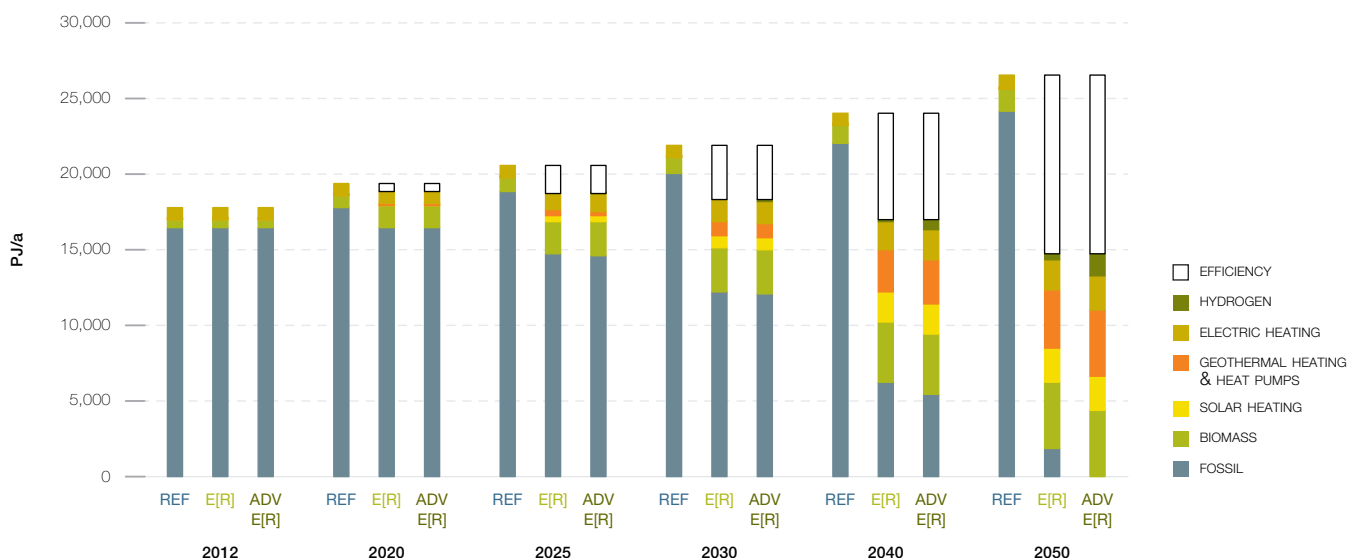
- Energy efficiency measures help to reduce the currently growing energy demand for heating by 44% in 2050 (relative to the Reference scenario), in spite of improving living standards and economic growth.
- In the industry sector solar collectors, geothermal energy (incl. heat pumps) as well as electricity and hydrogen from renewable sources are increasingly substituting for fossil fuel-fired systems.
- A shift from coal and oil to natural gas in the remaining conventional applications leads to a further reduction of CO<sub>2</sub> emissions.

Table 6.7.2 shows the development of different renewable technologies for heating in Eastern Europe/Eurasia over time. Up to 2030 biomass remains the main contributor of the growing market share. After 2030, the continuing growth of solar collectors and a growing share of geothermal and environmental heat as well as heat from renewable hydrogen will further reduce the dependence on fossil fuels. The Advanced scenario results in a complete substitution of the remaining gas consumption by hydrogen generated from renewable electricity.

**TABLE 6.7.2 | EASTERN EUROPE/EURASIA: PROJECTION OF RENEWABLE HEAT SUPPLY UNDER THE REFERENCE AND BOTH ENERGY [R]EVOLUTION SCENARIOS** IN PJ/a

		2012	2020	2030	2040	2050
BIOMASS	REF	509	904	995	1,190	1,421
	E[R]	509	2,188	2,850	4,047	4,365
	ADV	509	2,188	2,850	4,042	4,360
SOLAR HEATING	REF	4	7	8	10	14
	E[R]	4	361	840	2,014	2,271
	ADV	4	361	840	2,014	2,273
GEOHERMAL HEAT AND HEAT PUMPS	REF	6	8	9	12	15
	E[R]	6	343	922	2,741	3,794
	ADV	6	343	922	2,863	4,332
HYDROGEN	REF	0	0	0	0	0
	E[R]	0	0	0	146	442
	ADV	0	44	162	692	1,492
TOTAL	REF	519	918	1,012	1,213	1,449
	E[R]	519	2,891	4,611	8,949	10,872
	ADV	519	2,935	4,775	9,609	12,457

**FIGURE 6.7.8 | EASTERN EUROPE/EURASIA: PROJECTION OF HEAT SUPPLY BY ENERGY CARRIER – REFERENCE, ENERGY [R]EVOLUTION, ADVANCED ENERGY [R]EVOLUTION SCENARIOS**



### 6.7.6 FUTURE INVESTMENTS IN THE HEATING SECTOR

Also in the heating sector the Energy [R]evolution scenarios would require a major revision of current investment strategies in heating technologies. In particular, solar thermal, geothermal and heat pump technologies need an enormous increase in installations if these potentials are to be tapped for the heating sector. The use of biomass for heating purposes - often traditional biomass today - will be substantially reduced in the Energy [R]evolution scenarios and replaced by more efficient and sustainable renewable heating technologies.

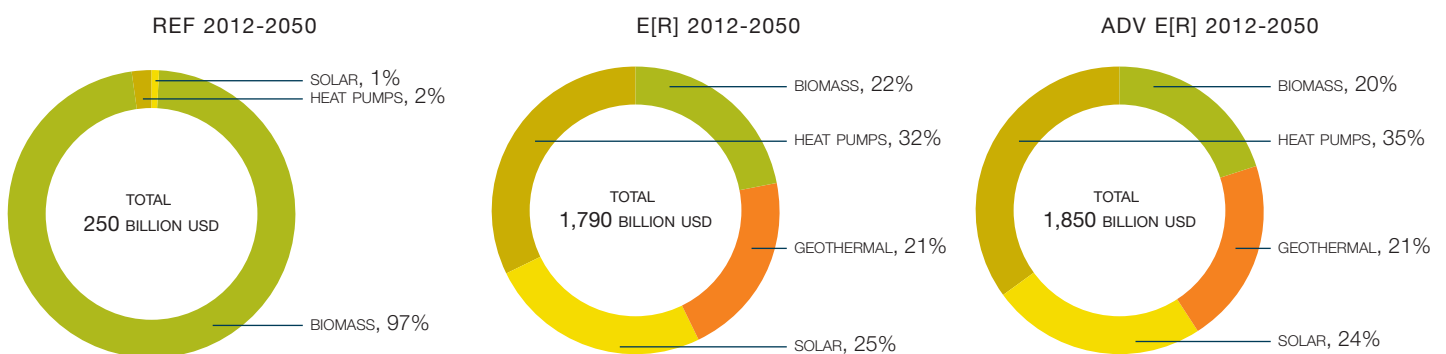
Renewable heating technologies are extremely variable, from low tech biomass stoves and unglazed solar collectors to very sophisticated enhanced geothermal and solar systems. Thus, it can only be roughly estimated that the Energy [R]evolution scenario in total requires around US\$ 1,790 billion to be invested in renewable heating technologies up to 2050 (including investments for replacement after the economic lifetime of the plants) - approximately US\$ 46 billion per year. The Advanced scenario assumes an even more ambitious expansion of renewable technologies resulting in an average investment of around US\$ 48 billion per year, while the main strategy in the scenario is the substitution of the remaining natural gas amounts with hydrogen or other synthetic fuels.

**TABLE 6.7.3 | EASTERN EUROPE/EURASIA: INSTALLED CAPACITIES FOR RENEWABLE HEAT GENERATION UNDER THE SCENARIOS** IN GW

		2012	2020	2030	2040	2050
BIOMASS	REF	108	171	195	220	248
	E[R]	108	224	349	412	385
	ADV	108	224	349	411	380
GEOTHERMAL	REF	0	0	0	0	0
	E[R]	0	1	49	151	193
	ADV	0	1	49	151	197
SOLAR HEATING	REF	1	1	2	3	3
	E[R]	1	14	182	445	503
	ADV	1	14	182	445	506
HEAT PUMPS	REF	1	1	2	2	3
	E[R]	1	8	76	213	276
	ADV	1	8	76	232	321
TOTAL*	REF	110	174	198	224	254
	E[R]	110	247	655	1,221	1,357
	ADV	110	247	655	1,238	1,404

\* Excluding direct electric heating.

**FIGURE 6.7.9 | EASTERN EUROPE/EURASIA: DEVELOPMENT OF INVESTMENTS FOR RENEWABLE HEAT GENERATION TECHNOLOGIES - REFERENCE, ENERGY [R]EVOLUTION, ADVANCED ENERGY [R]EVOLUTION SCENARIOS**



### 6.7.7 FUTURE EMPLOYMENT IN THE ENERGY SECTOR

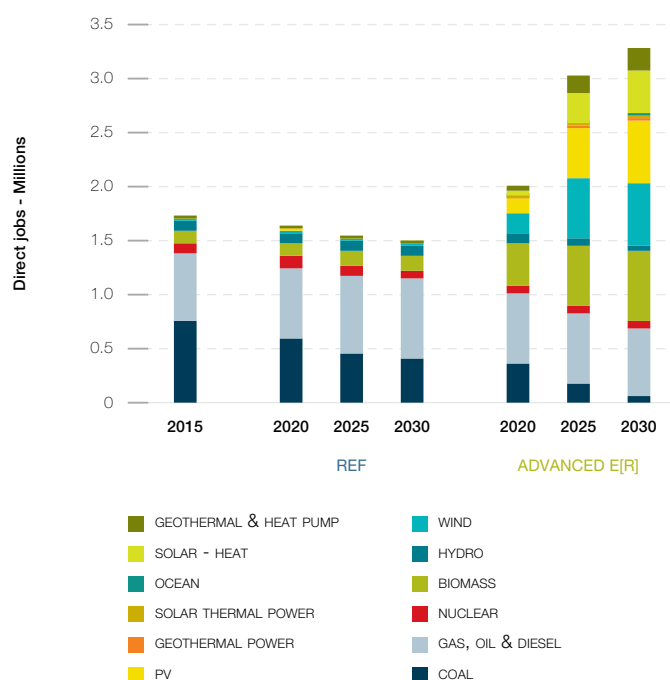
The Advanced Energy [R]evolution scenario results in more energy sector jobs in Eastern Europe/Eurasia at every stage of the projection.

- There are 2 million energy sector jobs in the Advanced Energy [R]evolution in 2020, and 1.6 million in the Reference scenario.
- In 2025, there are 3 million jobs in the Advanced Energy [R]evolution scenario, and 1.5 million in the Reference scenario.
- In 2030, there are 3.3 million jobs in the Advanced Energy [R]evolution scenario and 1.5 million in the Reference scenario.

Figure 6.7.10 shows the change in job numbers under both scenarios for each technology between 2015 and 2030. Jobs in the Reference scenario reduce gradually over the period, leading to an overall decline of 14% by 2030.

Strong growth in renewable energy leads to an increase of 16% in total energy sector jobs in the Advanced Energy [R]evolution scenario by 2020, compensating for a strong decline in coal. Jobs continue to grow until 2030, reaching 91% above 2015 levels. Renewable energy accounts for 77% of energy jobs by 2030, with biomass having the greatest share (20%).

**FIGURE 6.7.10 | EASTERN EUROPE/EURASIA: EMPLOYMENT IN THE ENERGY SECTOR UNDER THE REFERENCE AND ADVANCED ENERGY [R]EVOLUTION SCENARIO**



**TABLE 6.7.4 | EASTERN EUROPE/EURASIA: TOTAL EMPLOYMENT IN THE ENERGY SECTOR IN THOUSAND JOBS**

	2015	2020	REFERENCE		ADVANCED ENERGY [R]EVOLUTION		
			2025	2030	2020	2025	2030
COAL	752	586	465	407	356	173	55
GAS, OIL & DIESEL	631	657	701	736	646	642	635
NUCLEAR	104	115	101	83	70	71	68
RENEWABLES	234	250	260	258	930	2,144	2,523
<b>TOTAL JOBS</b>	<b>1,720</b>	<b>1,609</b>	<b>1,527</b>	<b>1,485</b>	<b>2,003</b>	<b>3,030</b>	<b>3,281</b>
CONSTRUCTION AND INSTALLATION	89	105	84	82	387	985	1,089
MANUFACTURING	32	41	37	42	168	502	567
OPERATIONS AND MAINTENANCE	318	336	340	319	403	557	707
FUEL SUPPLY (DOMESTIC)	1,047	838	754	707	886.2	844	779
COAL AND GAS EXPORT	235	288	312	334	158	143	139
<b>TOTAL JOBS</b>	<b>1,720</b>	<b>1,609</b>	<b>1,527</b>	<b>1,485</b>	<b>2,003</b>	<b>3,030</b>	<b>3,281</b>

### 6.7.8 TRANSPORT

A key target in Eastern Europe/Eurasia is to introduce incentives for people to drive smaller cars and buy new, more efficient vehicle concepts. In addition, it is vital to shift transport use to efficient modes like rail, light rail and buses, especially in the metropolitan areas. Along with rising prices for fossil fuels, these changes reduce the further growth in car sales projected under the Reference scenario. Due to population increase, GDP growth and higher living standards, energy demand from the transport sector is expected to increase in the Reference scenario by around 38% to 8,310 PJ/a in 2050. In the basic Energy [R]evolution scenario, efficiency measures and modal shifts will save 49% (4,060 PJ/a) in 2050 compared to the Reference scenario.

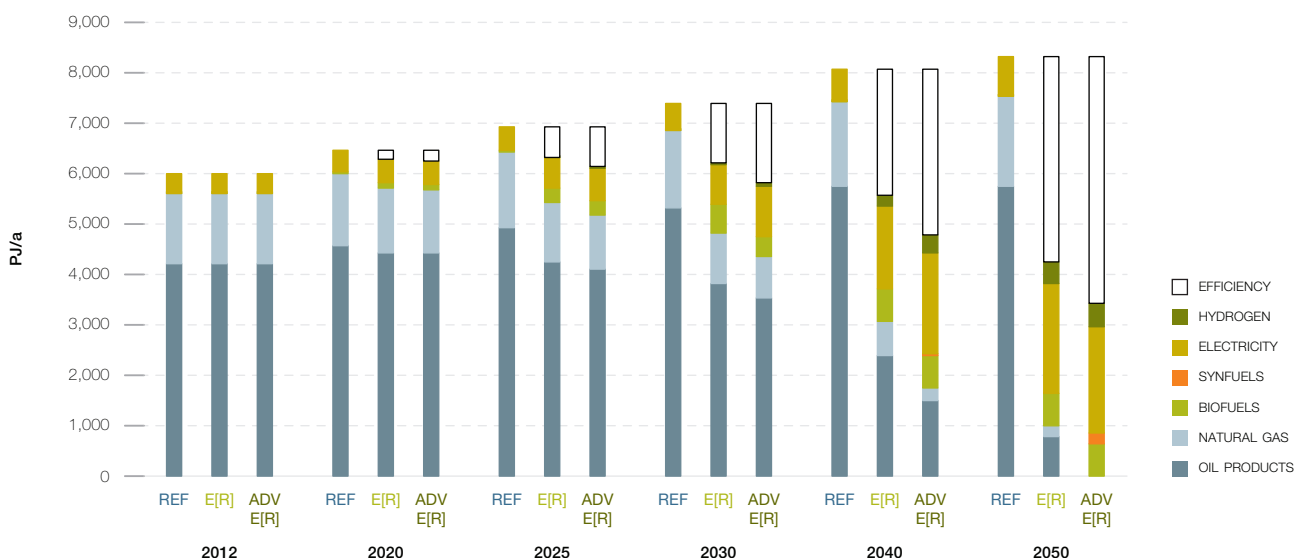
Additional modal shifts and technology switches lead to even higher energy savings in the Advanced scenario of 59% (4,880 PJ/a) in 2050 compared to the Reference scenario. Highly efficient propulsion technology with hybrid, plug-in hybrid and battery-electric power trains will bring about large efficiency gains. By 2030, electricity will provide 13% of the transport sector's total energy demand in the Energy [R]evolution, while in 2050 the share will be 51% (61% in the Advanced scenario). Hydrogen and other synthetic fuels generated using renewable electricity are complementary options to further increase the renewable share in the transport sector. In 2050, up to 460 PJ/a of hydrogen is used in the transport sector for the Advanced Energy [R]evolution scenario.

**TABLE 6.7.5 | EASTERN EUROPE/EURASIA: PROJECTION OF TRANSPORT ENERGY DEMAND BY MODE IN THE REFERENCE AND THE ENERGY [R]EVOLUTION SCENARIOS IN PJ/a**

		2012	2020	2030	2040	2050
RAIL	REF	591	658	682	732	777
	E[R]	591	639	685	740	780
	ADV	591	639	749	910	985
ROAD	REF	3,712	4,450	4,846	5,404	5,515
	E[R]	3,712	4,013	4,151	3,729	2,648
	ADV	3,712	4,013	3,859	3,040	1,990
DOMESTIC AVIATION	REF	297	360	382	429	474
	E[R]	297	337	347	357	365
	ADV	297	337	330	311	292
DOMESTIC NAVIGATION	REF	45	68	71	72	75
	E[R]	45	66	65	61	57
	ADV	45	66	65	61	57
TOTAL	REF	4,646	5,536	5,981	6,636	6,841
	E[R]	4,646	5,055	5,248	4,888	3,850
	ADV	4,646	5,055	5,004	4,322	3,324

6

**FIGURE 6.7.11 | EASTERN EUROPE/EURASIA: FINAL ENERGY CONSUMPTION IN TRANSPORT UNDER THE SCENARIOS**



### 6.7.10 DEVELOPMENT OF CO<sub>2</sub> EMISSIONS

Whilst Eastern Europe/Eurasia's emissions of CO<sub>2</sub> will increase by 31% between 2012 and 2050 under the Reference scenario, under the Energy [R]evolution scenario they will decrease from 2,710 million tonnes in 2012 to 317 million tonnes in 2050. Annual per capita emissions will drop from 8 tonne to 1 tonne. In spite of the abstinence of nuclear power production and increasing power demand, CO<sub>2</sub> emissions will decrease in the electricity sector. In the long run efficiency gains and the increased use of renewable electricity in vehicles strongly reduce emissions in the transport sector as well.

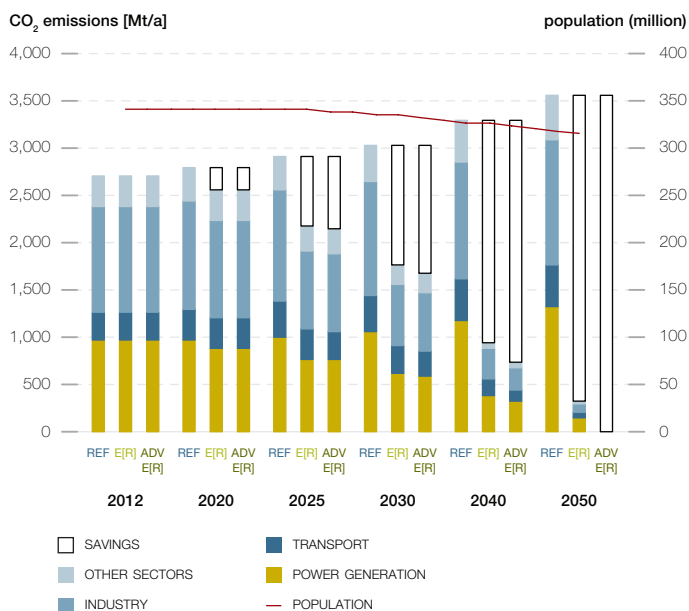
With a 39% share of CO<sub>2</sub>, the Power generation sector will be the largest source of emissions in 2050 in the basic Energy [R]evolution scenario. By 2050, Eastern Europe/Eurasia's CO<sub>2</sub> emissions are around 92% below 1990 levels in the Energy [R]evolution scenario while energy consumption is fully decarbonised in the Advanced case.

### 6.7.11 PRIMARY ENERGY CONSUMPTION

Taking into account the assumptions discussed above, the resulting primary energy consumption under the Energy [R]evolution scenarios is shown in Figure 6.7.12. Under the basic Energy [R]evolution scenario, primary energy demand will decrease by 29% from today's 49,310 PJ/a to around 35,000 PJ/a. Compared to the Reference scenario, overall primary energy demand will be reduced by 47% in 2050 under the Energy [R]evolution scenario (Reference scenario: around 66,000 PJ in 2050). The Advanced scenario results due to additional conversion losses in a primary energy consumption of around 39,700 PJ in 2050.

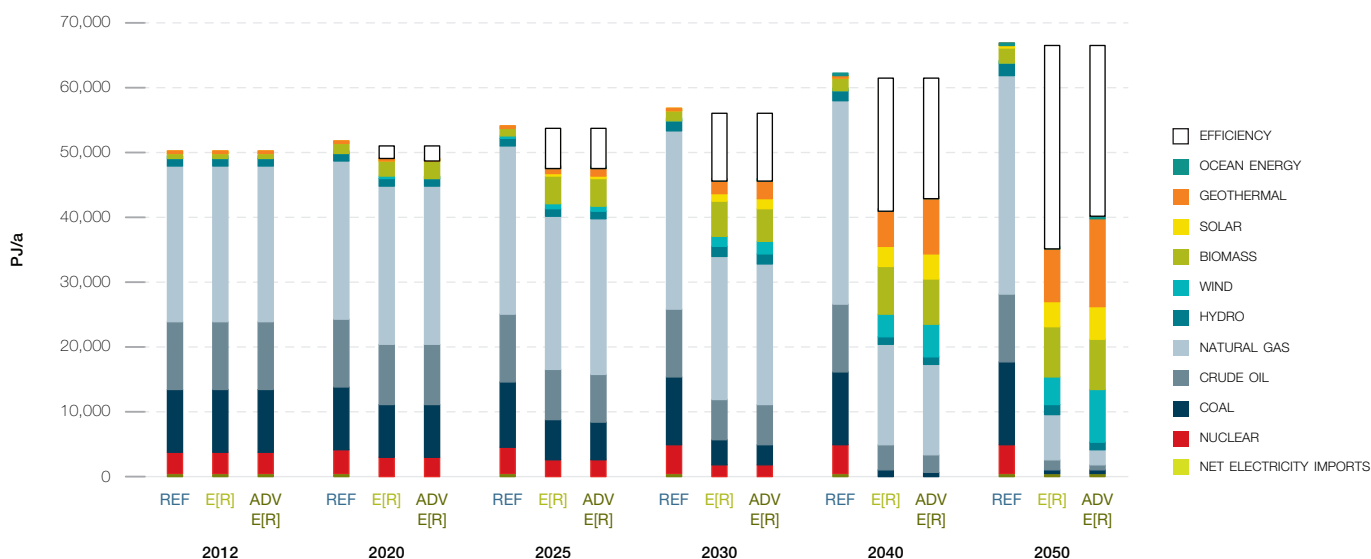
The Energy [R]evolution scenarios aim to phase out coal and oil as fast as technically and economically possible by expansion of

**FIGURE 6.7.13 | EASTERN EUROPE/EURASIA: DEVELOPMENT OF CO<sub>2</sub> EMISSIONS BY SECTOR UNDER THE ENERGY [R]EVOLUTION SCENARIOS** 'SAVINGS' = REDUCTION COMPARED TO THE REFERENCE SCENARIO



renewable energies and a fast introduction of very efficient vehicle concepts in the transport sector to replace oil based combustion engines. This leads to an overall renewable primary energy share of 25% in 2030 and 73% in 2050 in the basic Energy [R]evolution and of more than 91% in 2050 in the Advanced case (incl. non-energy consumption). In contrast to the Reference scenario, no new nuclear power plants will be built in Eastern Europe/Eurasia in the Energy [R]evolution scenarios.

**FIGURE 6.7.12 | EASTERN EUROPE/EURASIA: PROJECTION OF TOTAL PRIMARY ENERGY DEMAND (PED) BY ENERGY CARRIER INCLUDING ELECTRICITY** INCLUDING ELECTRICITY IMPORT BALANCE – REFERENCE, ENERGY [R]EVOLUTION, ADVANCED ENERGY [R]EVOLUTION SCENARIOS





**TABLE 6.7.6 | EASTERN EUROPE/EURASIA: ACCUMULATED INVESTMENT COSTS FOR ELECTRICITY GENERATION AND FUEL COST SAVINGS UNDER THE ENERGY [R]EVOLUTION SCENARIO COMPARED TO THE REFERENCE SCENARIO**

ACCUMULATED INVESTMENT COSTS DIFFERENCE REF MINUS E[R]	UNIT	2012-2020	2021-2030	2031-2040	2041-2050	2012-2050	2012 - 2050 AVERAGE PER YEAR
CONVENTIONAL (FOSSIL + NUCLEAR)	BILLION \$	36.0	112.7	85.3	166.3	400.3	10.3
RENEWABLES (INCL. CHP)	BILLION \$	-37.4	-504.1	-715.3	-857.1	-2,113.9	-54.2
TOTAL	BILLION \$	-1.4	-391.3	-630.0	-690.8	-1,713.6	-43.9
<b>ACCUMULATED FUEL COST SAVINGS</b>							
SAVINGS CUMULATIVE E[R] VERSUS REF							
FUEL OIL	BILLION \$	3.4	21.4	13.8	3.0	41.5	1.1
GAS	BILLION \$	-4.5	219.7	750.9	1,380.3	2,346.4	60.2
HARD COAL	BILLION \$	7.5	78.6	180.6	256.4	523.2	13.4
LIGNITE	BILLION \$	3.0	23.1	43.0	51.5	120.6	3.1
NUCLEAR ENERGY	BILLION \$	3.5	36.5	86.9	122.3	249.1	6.4
TOTAL	BILLION \$	12.8	379.2	1,075.3	1,813.6	3,280.9	84.1

**TABLE 6.7.7 | EASTERN EUROPE/EURASIA: ACCUMULATED INVESTMENT COSTS FOR RENEWABLE HEAT GENERATION UNDER THE ENERGY [R]EVOLUTION SCENARIO COMPARED TO THE REFERENCE SCENARIO**

ACCUMULATED INVESTMENT COSTS DIFFERENCE REF MINUS E[R]	UNIT	2012-2020	2021-2030	2031-2040	2041-2050	2012-2050	2012 - 2050 AVERAGE PER YEAR
RENEWABLES	BILLION \$	58.3	320.6	666.1	495.1	1,540.1	39.5

**TABLE 6.7.8 | EASTERN EUROPE/EURASIA: ACCUMULATED INVESTMENT COSTS FOR ELECTRICITY GENERATION AND FUEL COST SAVINGS UNDER THE ADVANCED ENERGY [R]EVOLUTION SCENARIO COMPARED TO THE REFERENCE SCENARIO**

ACCUMULATED INVESTMENT COSTS DIFFERENCE REF MINUS ADVANCED E[R]	UNIT	2012-2020	2021-2030	2031-2040	2041-2050	2012-2050	2012 - 2050 AVERAGE PER YEAR
CONVENTIONAL (FOSSIL + NUCLEAR)	BILLION \$	33.1	116.2	54.2	163.0	366.4	9.4
RENEWABLES (INCL. CHP)	BILLION \$	-37.9	-756.3	-1,133.2	-1,572.4	-3,499.8	-89.7
TOTAL	BILLION \$	-4.9	-640.1	-1,079.0	-1,409.4	-3,133.4	-80.3
<b>ACCUMULATED FUEL COST SAVINGS</b>							
SAVINGS CUMULATIVE ADVANCED E[R] VERSUS REF							
FUEL OIL	BILLION \$	3.4	21.4	13.8	3.0	41.5	1.1
GAS	BILLION \$	-4.5	228.7	799.4	1,568.3	2,591.9	66.5
HARD COAL	BILLION \$	7.5	83.0	189.6	257.5	537.7	13.8
LIGNITE	BILLION \$	3.0	23.1	43.0	51.5	120.6	3.1
NUCLEAR ENERGY	BILLION \$	3.5	36.5	86.9	122.3	249.1	6.4
TOTAL	BILLION \$	12.9	392.6	1,132.7	2,002.7	3,540.9	90.8

**TABLE 6.7.9 | EASTERN EUROPE/EURASIA: ACCUMULATED INVESTMENT COSTS FOR RENEWABLE HEAT GENERATION UNDER THE ADVANCED ENERGY [R]EVOLUTION SCENARIO COMPARED TO THE REFERENCE SCENARIO**

ACCUMULATED INVESTMENT COSTS DIFFERENCE REF MINUS ADVANCED E[R]	UNIT	2012-2020	2021-2030	2031-2040	2041-2050	2012-2050	2012 - 2050 AVERAGE PER YEAR
RENEWABLES	BILLION \$	58.3	320.6	695.1	528.7	1,602.7	41.1

## 6.8 INDIA

### 6.8.1 FINAL ENERGY DEMAND BY SECTOR

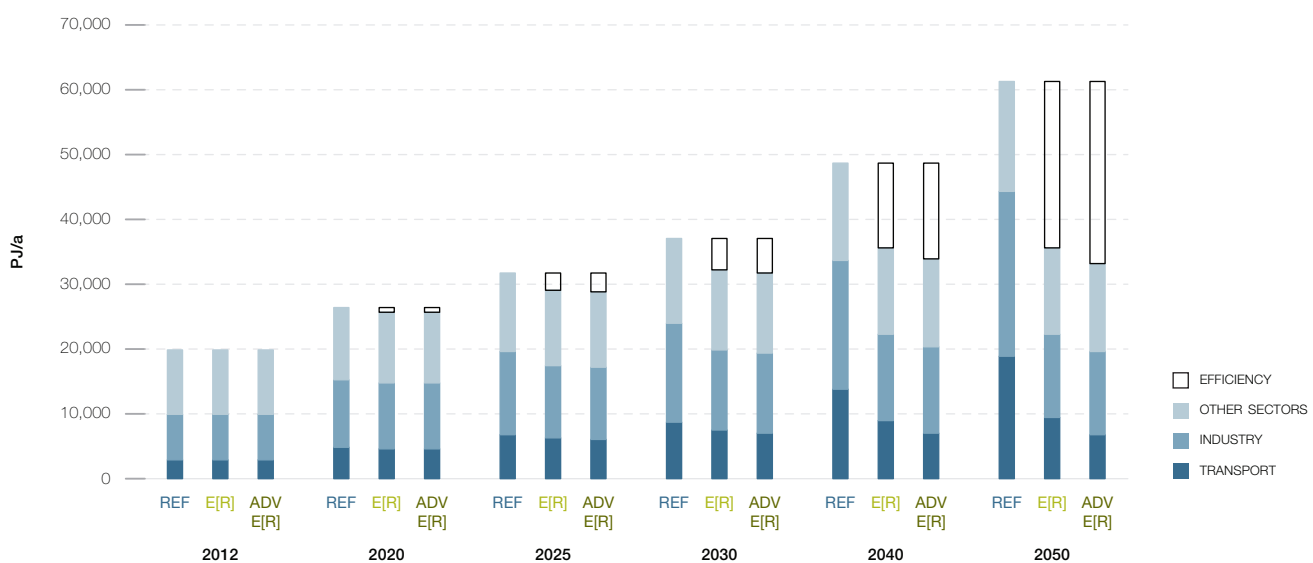
Combining the projections on population development, GDP growth and energy intensity results in future development pathways for India's final energy demand. These are shown in Figure 6.8.1 for the Reference and Energy [R]evolution scenarios. Under the Reference scenario, total final energy demand increases by 208% from the current 19,900 PJ/a to 61,200 PJ/a in 2050. In the basic Energy [R]evolution scenario, final energy demand increases at a much lower rate by 79% compared to current consumption and is expected to reach 35,600 PJ/a by 2050. The Advanced scenario results in some additional reductions due to a higher share of electric cars.

Under both Energy [R]evolution scenarios, due to economic growth, increasing living standards and electrification of the transport sector, overall electricity demand is expected to increase despite efficiency gains in all sectors (see Figure 6.8.2). Total electricity demand will decrease from about 870 TWh/a to 4,920 TWh/a by 2050 in the basic Energy [R]evolution scenario. Compared to the Reference scenario, efficiency measures in the industry, residential and service sectors avoid the generation of about 1,080 TWh/a.

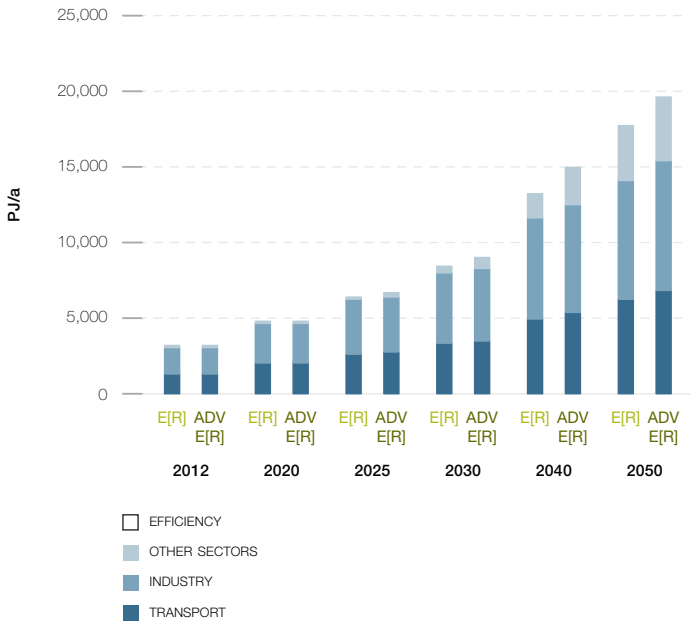
This reduction can be achieved in particular by introducing highly efficient electronic devices using the best available technology in all demand sectors. The transformation to a carbon free energy system in the Advanced scenario will further increase the electricity demand in 2050 up to 5,500 TWh/a. Electricity will become the major renewable 'primary' energy, not only for direct use for various purposes but also for the generation of synthetic fuels for fossil fuels substitution. Around 1,190 TWh are used in 2050 for electric vehicles and rail transport in 2050 in the Advanced scenario, around 440 TWh for hydrogen and 540 TWh for synthetic liquid fuel generation for the transport sector (excluding bunkers).

Efficiency gains in the heating sector are even larger than in the electricity sector. Under the Energy [R]evolution scenarios, consumption equivalent to about 6,200 PJ/a is avoided through efficiency gains by 2050 compared to the Reference scenario. As a result of energy-related renovation of the existing stock of residential buildings, the introduction of low energy standards and 'passive climatisation' for new buildings, as well as highly efficient air conditioning systems, enjoyment of the same comfort and energy services will be accompanied with much lower future energy demand.

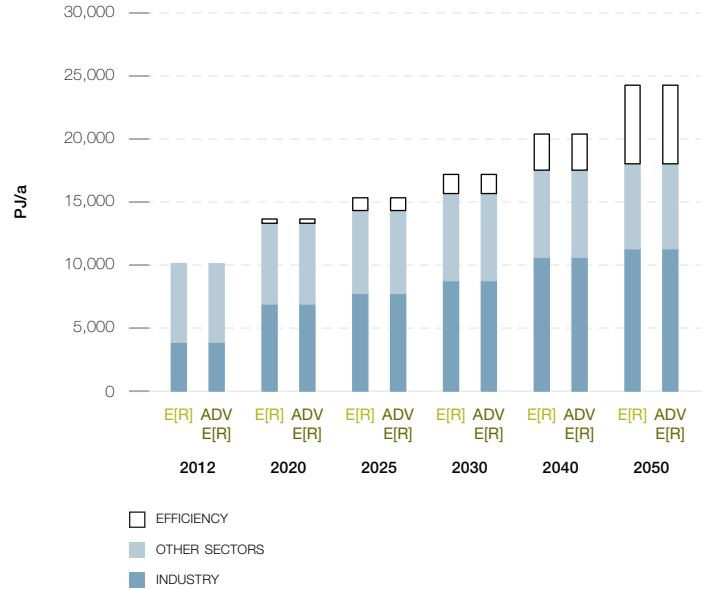
**FIGURE 6.8.1 | INDIA: PROJECTION OF TOTAL FINAL ENERGY DEMAND BY SECTOR – REFERENCE, ENERGY [R]EVOLUTION, ADVANCED ENERGY [R]EVOLUTION SCENARIOS** WITHOUT NON-ENERGY USE AND HEAT FROM CHP AUTOPRODUCERS



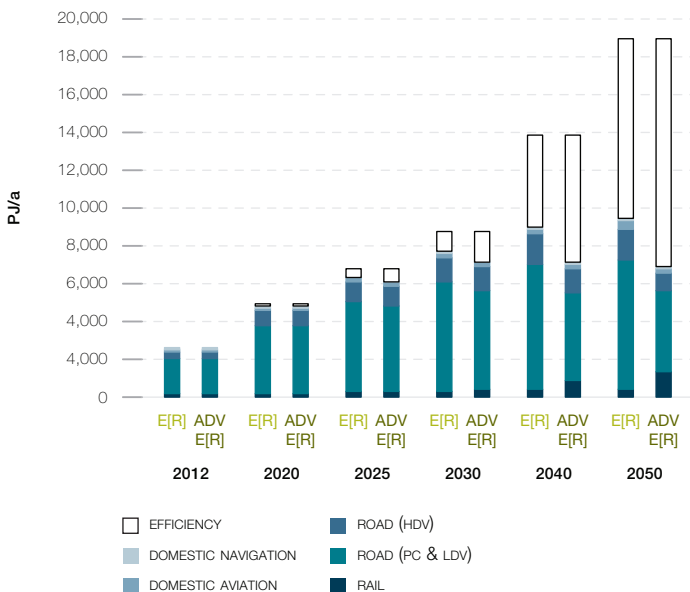
**FIGURE 6.8.2 | INDIA: DEVELOPMENT OF ELECTRICITY DEMAND BY SECTOR IN THE ENERGY [R]EVOLUTION SCENARIOS**



**FIGURE 6.8.4 | INDIA: DEVELOPMENT OF FINAL ENERGY DEMAND FOR HEAT BY SECTOR IN THE ENERGY [R]EVOLUTION SCENARIOS**



**FIGURE 6.8.3 | INDIA: DEVELOPMENT OF THE FINAL ENERGY DEMAND FOR TRANSPORT BY SECTOR IN THE ENERGY [R]EVOLUTION SCENARIOS**



### 6.8.2 ELECTRICITY GENERATION

The development of the electricity supply sector is characterised by a dynamically growing renewable energy market and an increasing share of renewable electricity. This trend will more than compensate for the phasing out of nuclear power production in the Energy [R]evolution scenarios, continuously reducing the number of fossil fuel-fired power plants as well. By 2050, 93% of the electricity produced in India will come from renewable energy sources in the basic Energy [R]evolution scenario. 'New' renewables – mainly wind, PV, CSP and geothermal energy – will contribute 71% to the total electricity generation. Already by 2020 the share of renewable electricity production will be 23% and 56% by 2030. The installed capacity of renewables will reach about 770 GW in 2030 and 2,240 GW by 2050.

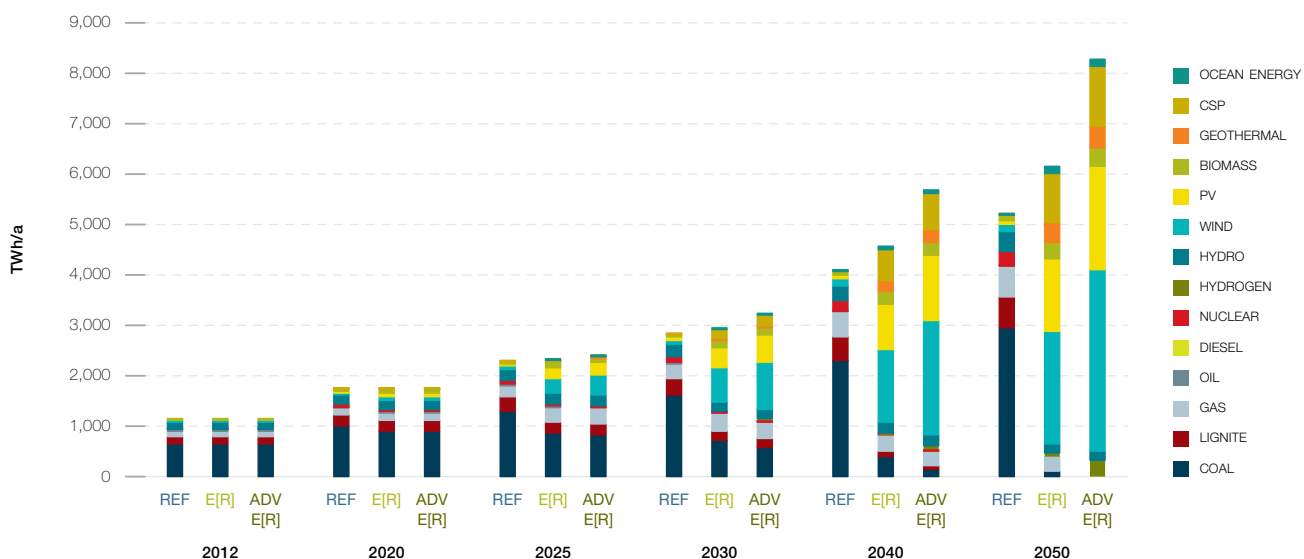
A 100% electricity supply from renewable energy resources in the Advanced scenario leads to around 3,260 GW installed generation capacity in 2050.

Table 6.8.1 shows the comparative evolution of the different renewable technologies in India over time. Up to 2020 wind and PV will become the main contributors to the growing market share. After 2020, the continuing growth of wind and PV will be complemented by electricity from solar thermal, geothermal and ocean energy. The Energy [R]evolution scenarios will lead to a high share of fluctuating power generation sources (PV, wind and ocean) of already 38% to 47% by 2030 and 62% to 70% by 2050. Therefore, smart grids, demand side management (DSM), energy storage capacities and other options need to be expanded in order to increase the flexibility of the power system for grid integration, load balancing and a secure supply of electricity.

**TABLE 6.8.1 | INDIA: PROJECTION OF RENEWABLE ELECTRICITY GENERATION CAPACITY UNDER THE REFERENCE AND THE ENERGY [R]EVOLUTION SCENARIOS** IN GW

		2012	2020	2030	2040	2050
HYDRO	REF	42	54	76	101	126
	E[R]	42	54	66	68	69
	ADV	42	54	66	68	69
BIOMASS	REF	6	9	12	15	19
	E[R]	6	14	30	51	79
	ADV	6	14	29	54	87
WIND	REF	18	34	50	62	72
	E[R]	18	43	320	667	941
	ADV	18	46	449	1,048	1,518
GEOTHERMAL	REF	0	0	0	0	0
	E[R]	0	0	7	36	64
	ADV	0	0	8	43	73
PV	REF	1	15	35	47	59
	E[R]	1	64	302	576	841
	ADV	1	68	390	828	1,222
CSP	REF	0	0	0	0	0
	E[R]	0	1	40	125	194
	ADV	0	1	46	146	234
OCEAN	REF	0	0	0	0	0
	E[R]	0	0	10	28	52
	ADV	0	0	11	31	59
TOTAL	REF	68	112	173	226	277
	E[R]	68	176	775	1,551	2,240
	ADV	68	183	999	2,218	3,263

**FIGURE 6.8.5 | INDIA: DEVELOPMENT OF ELECTRICITY GENERATION STRUCTURE – REFERENCE, ENERGY [R]EVOLUTION, ADVANCED ENERGY [R]EVOLUTION SCENARIOS**



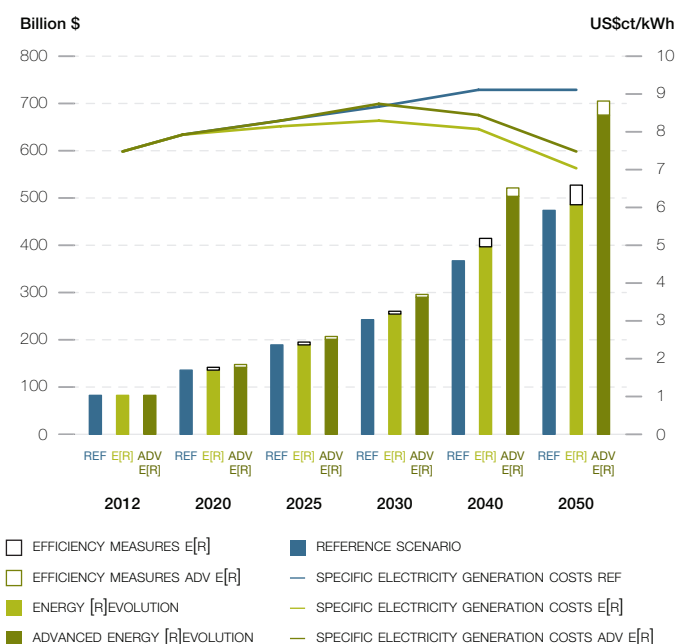
### 6.8.3 FUTURE COSTS OF ELECTRICITY GENERATION

Figure 6.8.6 shows that the introduction of renewable technologies under both Energy [R]evolution scenarios increases the future costs of electricity generation compared to the Reference scenario until 2030. This difference in full cost of generation will be about 0.1 US\$ct/kWh in the Advanced scenario, without taking into account integration costs for storage or other load-balancing measures. Because of increasing prices for conventional fuels, electricity generation costs will become economically favourable starting in 2030 under the Energy [R]evolution scenarios. By 2050, the cost will be 2.1/1.6 US\$ct/kWh, respectively, below those in the Reference case.

Under the Reference scenario, on the other hand, growth in demand and increasing fossil fuel prices result in total electricity supply costs rising from today's US\$ 84 billion per year to more than US\$ 471 billion in 2050, compared to US\$ 485 billion in the basic and US\$ 673 billion in the Advanced Energy [R]evolution scenario. Figure 6.8.6 shows that both Energy [R]evolution scenarios not only comply with India's CO<sub>2</sub> reduction targets, but also help stabilise energy costs and relieve the economic pressure on society.

Increasing energy efficiency and shifting energy supply to renewables lead to long term costs for electricity supply that are 3% higher than in the basic Energy [R]evolution scenario than in the Reference scenario, despite a 19% increase in electricity production. The Advanced scenario with 100% renewable power and an increase in power generation of 60% results in supply costs 43% higher than the Reference case.

**FIGURE 6.8.6 | INDIA: DEVELOPMENT OF TOTAL ELECTRICITY SUPPLY COSTS & OF SPECIFIC ELECTRICITY GENERATION COSTS IN THE SCENARIOS**



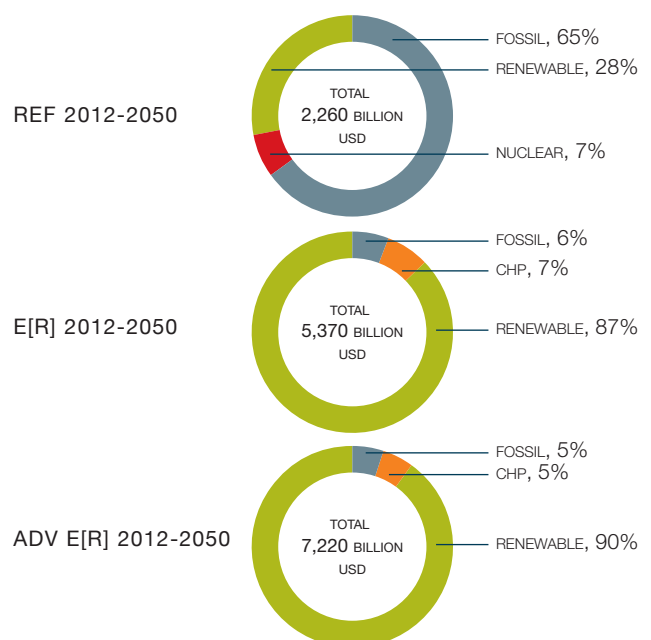
### 6.8.4 FUTURE INVESTMENTS IN THE POWER SECTOR

Around US\$ 5,370 billion is required in investment for the Energy [R]evolution scenario to become reality (including investments for replacement after the economic lifetime of the plants) - approximately US\$ 138 billion per year, US\$ 3,110 billion more than in the Reference scenario (US\$ 2,260 billion). Investments for the Advanced scenario add up to US\$ 7,220 billion until 2050, on average US\$ 185 billion per year, including high investments in additional power plants for the production of synthetic fuels. Under the Reference scenario, the levels of investment in conventional power plants add up to almost 72% while approximately 28% would be invested in renewable energies and cogeneration until 2050.

Under the Energy [R]evolution scenarios, however, India would shift up to 95% of the entire investment towards renewables and cogeneration. By 2030, the fossil fuel share of power sector investment would be focused mainly on gas power plants.

Because renewable energy has no fuel costs, the fuel cost savings in the basic Energy [R]evolution scenario reach a total of US\$ 3,430 billion up to 2050, US\$ 88 billion per year. The total fuel cost savings therefore would cover 110% of the total additional investments compared to the Reference scenario. Fuel cost savings in the Advanced scenario are even higher and add up to US\$ 3,720 billion, or US\$ 95 billion per year. Renewable energy sources would then go on to produce electricity without any further fuel costs beyond 2050, while costs for coal and gas will continue to be a burden on national economies.

**FIGURE 6.8.7 | INDIA: INVESTMENT SHARES - REFERENCE VERSUS ENERGY [R]EVOLUTION SCENARIOS**



### 6.8.5 ENERGY SUPPLY FOR HEATING

Today, renewables meet around 50% of India's energy demand for heat, the main contribution coming from the use of biomass. Dedicated support instruments are required to ensure a dynamic development in particular for renewable technologies for buildings and renewable process heat production. In the basic Energy [R]evolution scenario, renewables already provide 55% of India's total heat demand in 2030 and 87% in 2050.

- Energy efficiency measures help to reduce the currently growing energy demand for heating by 25% in 2050 (relative to the Reference scenario), in spite of improving living standards and economic growth.
- In the industry sector solar collectors, geothermal energy (incl. heat pumps) as well as electricity and hydrogen from renewable sources are increasingly substituting for fossil fuel-fired systems.
- A shift from coal and oil to natural gas in the remaining conventional applications leads to a further reduction of CO<sub>2</sub> emissions.

Table 6.8.2 shows the development of different renewable technologies for heating in India over time. Up to 2030 biomass remains the main contributor of the growing market share. After 2030, the continuing growth of solar collectors and a growing share of geothermal and environmental heat as well as heat from renewable hydrogen will further reduce the dependence on fossil fuels. The Advanced scenario results in a complete substitution of the remaining gas consumption by hydrogen generated from renewable electricity.

**TABLE 6.8.2 | INDIA: PROJECTION OF RENEWABLE HEAT SUPPLY UNDER THE REFERENCE AND BOTH ENERGY [R]EVOLUTION SCENARIOS** IN PJ/a

		2012	2020	2030	2040	2050
BIOMASS	REF	5,433	6,042	6,219	6,223	6,334
	E[R]	5,433	5,955	5,905	5,680	5,320
	ADV	5,433	5,955	5,905	5,680	5,320
SOLAR HEATING	REF	20	80	106	171	261
	E[R]	20	522	1,175	2,391	3,320
	ADV	20	521	1,175	2,392	3,436
GEOTHERMAL HEAT AND HEAT PUMPS	REF	0	1	1	1	2
	E[R]	0	175	641	1,678	2,940
	ADV	0	175	641	1,722	3,182
HYDROGEN	REF	0	0	0	0	0
	E[R]	0	0	8	164	614
	ADV	0	6	36	338	1,546
TOTAL	REF	5,453	6,123	6,326	6,396	6,597
	E[R]	5,453	6,653	7,731	9,913	12,194
	ADV	5,453	6,658	7,756	10,133	13,483

**FIGURE 6.8.8 | INDIA: PROJECTION OF HEAT SUPPLY BY ENERGY CARRIER – REFERENCE, ENERGY [R]EVOLUTION, ADVANCED ENERGY [R]EVOLUTION SCENARIOS**



### 6.8.6 FUTURE INVESTMENTS IN THE HEATING SECTOR

Also in the heating sector the Energy [R]evolution scenarios would require a major revision of current investment strategies in heating technologies. In particular, solar thermal, geothermal and heat pump technologies need an enormous increase in installations if these potentials are to be tapped for the heating sector. The use of biomass for heating purposes - often traditional biomass today - will be substantially reduced in the Energy [R]evolution scenarios and replaced by more efficient and sustainable renewable heating technologies.

Renewable heating technologies are extremely variable, from low tech biomass stoves and unglazed solar collectors to very sophisticated enhanced geothermal and solar systems. Thus, it can only be roughly estimated that the Energy [R]evolution scenario in total requires around US\$ 1,020 billion to be invested in renewable heating technologies up to 2050 (including investments for replacement after the economic lifetime of the plants) - approximately US\$ 26 billion per year. The Advanced scenario assumes an even more ambitious expansion of renewable technologies resulting in an average investment of around US\$ 27 billion per year, while the main strategy in the scenario is the substitution of the remaining natural gas amounts with hydrogen or other synthetic fuels.

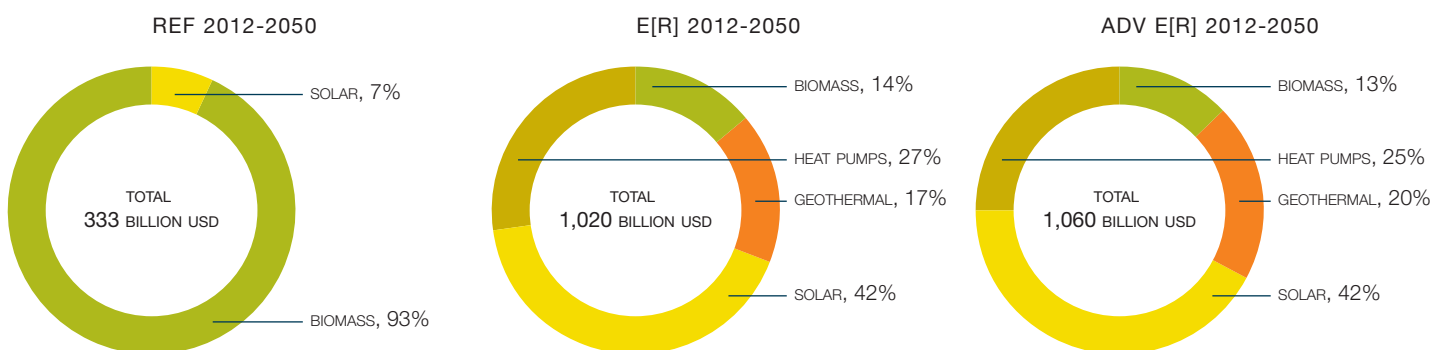
**TABLE 6.8.3 | INDIA: INSTALLED CAPACITIES FOR RENEWABLE HEAT GENERATION UNDER THE SCENARIOS**

IN GW

		2012	2020	2030	2040	2050
BIOMASS	REF	2,200	2,290	2,240	2,040	1,860
	E[R]	2,200	2,240	2,050	1,690	1,270
	ADV	2,200	2,240	2,050	1,690	1,270
GEOTHERMAL	REF	0	0	0	0	0
	E[R]	0	0	13	38	82
	ADV	0	0	13	42	101
SOLAR HEATING	REF	5	13	25	40	60
	E[R]	5	19	270	540	730
	ADV	5	19	270	540	750
HEAT PUMPS	REF	0	0	0	0	0
	E[R]	0	1	37	80	130
	ADV	0	1	37	80	130
TOTAL*	REF	2,205	2,303	2,265	2,080	1,921
	E[R]	2,205	2,260	2,370	2,348	2,212
	ADV	2,205	2,260	2,370	2,352	2,251

\* Excluding direct electric heating.

**FIGURE 6.8.9 | INDIA: DEVELOPMENT OF INVESTMENTS FOR RENEWABLE HEAT GENERATION TECHNOLOGIES – REFERENCE, ENERGY [R]EVOLUTION, ADVANCED ENERGY [R]EVOLUTION SCENARIOS**



### 6.8.7 FUTURE EMPLOYMENT IN THE ENERGY SECTOR

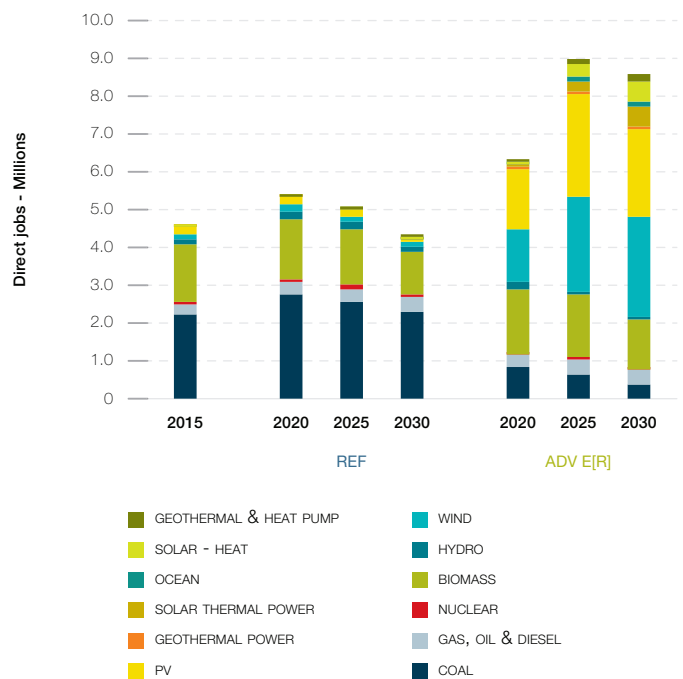
The Advanced Energy [R]evolution scenario results in more energy sector jobs in India at every stage of the projection.

- There are 6.3 million energy sector jobs in the Advanced Energy [R]evolution in 2020, and 5.3 million in the Reference scenario.
- In 2025, there are 9 million jobs in the Advanced Energy [R]evolution scenario, and 5 million in the Reference scenario.
- In 2030, there are 8.6 million jobs in the Advanced Energy [R]evolution scenario and 4.3 million in the Reference scenario.

Figure 6.8.10 shows the change in job numbers under both scenarios for each technology between 2015 and 2030. Jobs in the Reference scenario increase by 17% by 2020, before declining to 6% below 2015 levels in 2030.

Exceptionally strong growth in renewable energy offsets losses in the fossil fuel sector. Advanced Energy [R]evolution jobs increase to 38% above 2015 levels in 2020 and are nearly double 2015 levels in 2025. Jobs reduce slightly from 2025 to 2030, but remain 88% above 2015 levels. Renewable energy accounts for 91% of energy jobs in 2030, with wind having the greatest share (31%), followed by solar PV, and biomass.

**FIGURE 6.8.10 | INDIA: EMPLOYMENT IN THE ENERGY SECTOR UNDER THE REFERENCE AND ADVANCED ENERGY [R]EVOLUTION SCENARIO**



**TABLE 6.8.4 | INDIA: TOTAL EMPLOYMENT IN THE ENERGY SECTOR IN THOUSAND JOBS**

	2015	2020	REFERENCE		ADVANCED ENERGY [R]EVOLUTION		
			2025	2030	2020	2025	2030
COAL	2,252	2,769	2,552	2,324	839	618	384
GAS, OIL & DIESEL	224	299	362	343	319	437	357
NUCLEAR	84	118	133	120	31	26	18
RENEWABLES	1,993	2,158	1,989	1,483	5,095	7,889	7,817
<b>TOTAL JOBS</b>	<b>4,554</b>	<b>5,344</b>	<b>5,035</b>	<b>4,271</b>	<b>6,284</b>	<b>8,969</b>	<b>8,576</b>
CONSTRUCTION AND INSTALLATION	1,241	1,637	1,445	1,221	1,496	2,866	2,799
MANUFACTURING	633	824	725	603	1,704	2,759	2,612
OPERATIONS AND MAINTENANCE	414	560	654	621	780	1,239	1,625
FUEL SUPPLY (DOMESTIC)	2,265	2,323	2,211	1,826	2,304.3	2,106	1,540
COAL AND GAS EXPORT	-	-	-	-	-	-	-
<b>TOTAL JOBS</b>	<b>4,554</b>	<b>5,344</b>	<b>5,035</b>	<b>4,271</b>	<b>6,284</b>	<b>8,969</b>	<b>8,576</b>



### 6.8.8 TRANSPORT

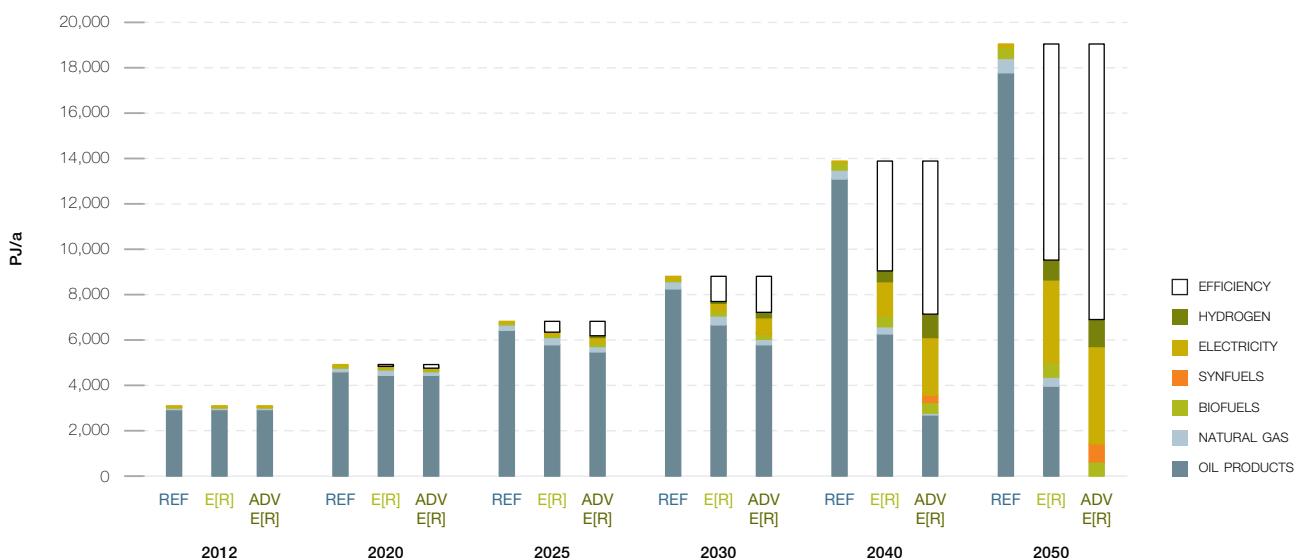
In 2050, the car fleet in India will be significantly larger than today. Therefore a key target is the successful introduction of highly efficient vehicle concepts. In addition, it is vital to shift transport use to efficient modes like rail, light rail and buses, especially in the expanding large metropolitan areas. Along with rising prices for fossil fuels, these changes reduce the further growth in car sales projected under the Reference scenario. Due to population increase, GDP growth and higher living standards, energy demand from the transport sector is expected to strongly increase in the Reference scenario by around 518% to 19,030 PJ/a in 2050. In the basic Energy [R]evolution scenario, efficiency measures and modal shifts will save 50% (9,530 PJ/a) in 2050 compared to the Reference scenario.

Additional modal shifts and technology switches lead to even higher energy savings in the Advanced scenario of 64% (12,100 PJ/a) in 2050 compared to the Reference scenario. Highly efficient propulsion technology with hybrid, plug-in hybrid and battery-electric power trains will bring about large efficiency gains. By 2030, electricity will provide 5% of the transport sector's total energy demand in the Energy [R]evolution, while in 2050 the share will be 38% (62% in the Advanced scenario). Hydrogen and other synthetic fuels generated using renewable electricity are complementary options to further increase the renewable share in the transport sector. In 2050, up to 1,220 PJ/a of hydrogen is used in the transport sector for the Advanced Energy [R]evolution scenario.

**TABLE 6.8.5 | INDIA: PROJECTION OF TRANSPORT ENERGY DEMAND BY MODE IN THE REFERENCE AND THE ENERGY [R]EVOLUTION SCENARIOS** IN PJ/a

		2012	2020	2030	2040	2050
RAIL	REF	168	261	297	356	387
	E[R]	168	228	314	390	450
	ADV	168	234	450	894	1,342
ROAD	REF	2,811	6,326	8,147	13,031	17,844
	E[R]	2,811	4,390	7,093	8,209	8,477
	ADV	2,811	4,356	6,458	5,849	5,196
DOMESTIC AVIATION	REF	71	175	227	379	632
	E[R]	71	132	216	322	442
	ADV	71	131	201	251	265
DOMESTIC NAVIGATION	REF	29	72	92	132	170
	E[R]	29	57	87	112	130
	ADV	29	57	87	112	130
TOTAL	REF	3,078	6,834	8,762	13,898	19,033
	E[R]	3,078	4,807	7,711	9,034	9,500
	ADV	3,078	4,779	7,196	7,107	6,934

**FIGURE 6.8.11 | INDIA: FINAL ENERGY CONSUMPTION IN TRANSPORT UNDER THE SCENARIOS**



### 6.8.10 DEVELOPMENT OF CO<sub>2</sub> EMISSIONS

Whilst India's emissions of CO<sub>2</sub> will increase by 248% between 2012 and 2050 under the Reference scenario, under the Energy [R]evolution scenario they will decrease from 1,950 million tonnes in 2012 to 780 million tonnes in 2050. Annual per capita emissions will drop from 1.6 tonne to 0.5 tonne. In spite of the abstinence of nuclear power production and increasing power demand, CO<sub>2</sub> emissions will decrease in the electricity sector. In the long run efficiency gains and the increased use of renewable electricity in vehicles strongly reduce emissions in the transport sector as well.

With a 34% share of CO<sub>2</sub>, the Transport sector will be the largest source of emissions in 2050 in the basic Energy [R]evolution scenario. By 2050, India's CO<sub>2</sub> emissions are still 34% above 1990 levels in the Energy [R]evolution scenario while energy consumption is fully decarbonised in the Advanced case.

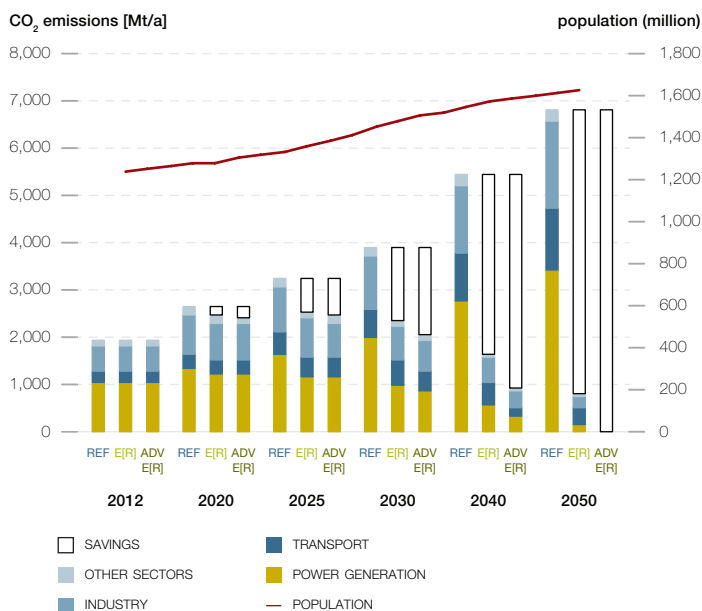
### 6.8.11 PRIMARY ENERGY CONSUMPTION

Taking into account the assumptions discussed above, the resulting primary energy consumption under the Energy [R]evolution scenarios is shown in Figure 6.8.12. Under the basic Energy [R]evolution scenario, primary energy demand will increase by 58% from today's 32,940 PJ/a to around 52,000 PJ/a. Compared to the Reference scenario, overall primary energy demand will be reduced by 47% in 2050 under the Energy [R]evolution scenario (Reference scenario: around 99,000 PJ in 2050). The Advanced scenario results in a primary energy consumption of around 51,300 PJ in 2050.

The Energy [R]evolution scenarios aim to phase out coal and oil as fast as technically and economically possible by expansion of renewable energies and a fast introduction of very efficient vehicle concepts in the transport sector to

**FIGURE 6.8.13 | INDIA: DEVELOPMENT OF CO<sub>2</sub> EMISSIONS BY SECTOR UNDER THE ENERGY [R]EVOLUTION SCENARIOS**

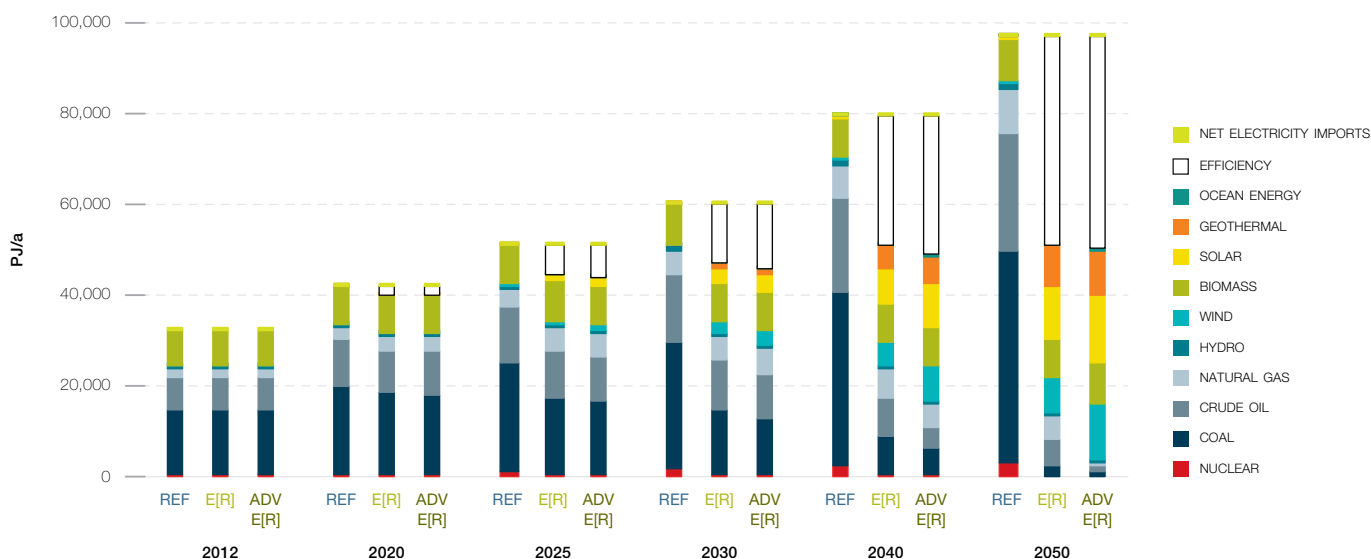
'SAVINGS' = REDUCTION COMPARED TO THE REFERENCE SCENARIO



replace oil based combustion engines. This leads to an overall renewable primary energy share of 34% in 2030 and 74% in 2050 in the basic Energy [R]evolution and of more than 94% in 2050 in the Advanced case (incl. non-energy consumption). In contrast to the Reference scenario, no new nuclear power plants will be built in India in the Energy [R]evolution scenarios.

**FIGURE 6.8.12 | INDIA: PROJECTION OF TOTAL PRIMARY ENERGY DEMAND (PED) BY ENERGY CARRIER**

INCLUDING ELECTRICITY IMPORT BALANCE – REFERENCE, ENERGY [R]EVOLUTION, ADVANCED ENERGY [R]EVOLUTION SCENARIOS



**TABLE 6.8.6 | INDIA: ACCUMULATED INVESTMENT COSTS FOR ELECTRICITY GENERATION AND FUEL COST SAVINGS UNDER THE ENERGY [R]EVOLUTION SCENARIO COMPARED TO THE REFERENCE SCENARIO**

ACCUMULATED INVESTMENT COSTS DIFFERENCE REF MINUS E[R]	UNIT	2012-2020	2021-2030	2031-2040	2041-2050	2012-2050	2012 - 2050 AVERAGE PER YEAR
CONVENTIONAL (FOSSIL + NUCLEAR)	BILLION \$	44.5	363.8	438.4	423.9	1,270.5	32.6
RENEWABLES (INCL. CHP)	BILLION \$	-114.7	-1,010.7	-1,504.5	-1,764.5	-4,394.3	-112.7
TOTAL	BILLION \$	-70.2	-646.9	-1,066.1	-1,340.6	-3,123.8	-80.1
<b>ACCUMULATED FUEL COST SAVINGS</b>							
SAVINGS CUMULATIVE E[R] VERSUS REF							
FUEL OIL	BILLION \$	2.9	17.8	31.8	20.5	73.0	1.9
GAS	BILLION \$	-5.3	-33.0	150.7	386.1	498.6	12.8
HARD COAL	BILLION \$	15.5	322.5	874.0	1,354.0	2,566.1	65.8
LIGNITE	BILLION \$	0.9	15.7	58.4	124.3	199.2	5.1
NUCLEAR ENERGY	BILLION \$	0.5	8.9	27.0	54.3	90.7	2.3
TOTAL	BILLION \$	14.6	331.9	1,142.0	1,939.1	3,427.6	87.9

**TABLE 6.8.7 | INDIA: ACCUMULATED INVESTMENT COSTS FOR RENEWABLE HEAT GENERATION UNDER THE ENERGY [R]EVOLUTION SCENARIO COMPARED TO THE REFERENCE SCENARIO**

ACCUMULATED INVESTMENT COSTS DIFFERENCE REF MINUS E[R]	UNIT	2012-2020	2021-2030	2031-2040	2041-2050	2012-2050	2012 - 2050 AVERAGE PER YEAR
RENEWABLES	BILLION \$	-61.4	161.2	224.8	360.1	684.7	17.6

**TABLE 6.8.8 | INDIA: ACCUMULATED INVESTMENT COSTS FOR ELECTRICITY GENERATION AND FUEL COST SAVINGS UNDER THE ADVANCED ENERGY [R]EVOLUTION SCENARIO COMPARED TO THE REFERENCE SCENARIO**

ACCUMULATED INVESTMENT COSTS DIFFERENCE REF MINUS ADVANCED E[R]	UNIT	2012-2020	2021-2030	2031-2040	2041-2050	2012-2050	2012 - 2050 AVERAGE PER YEAR
CONVENTIONAL (FOSSIL + NUCLEAR)	BILLION \$	44.8	365.7	437.9	406.5	1,254.8	32.2
RENEWABLES (INCL. CHP)	BILLION \$	-130.9	-1,377.2	-2,179.3	-2,545.9	-6,233.3	-159.8
TOTAL	BILLION \$	-86.2	-1,011.5	-1,741.4	-2,139.5	-4,978.5	-127.7
<b>ACCUMULATED FUEL COST SAVINGS</b>							
SAVINGS CUMULATIVE ADVANCED E[R] VERSUS REF							
FUEL OIL	BILLION \$	2.9	17.8	31.8	20.5	73.0	1.9
GAS	BILLION \$	-5.3	-30.6	167.7	485.6	617.3	15.8
HARD COAL	BILLION \$	15.7	346.2	961.6	1,416.0	2,739.5	70.2
LIGNITE	BILLION \$	0.9	15.7	58.4	124.3	199.2	5.1
NUCLEAR ENERGY	BILLION \$	0.5	8.9	27.0	54.3	90.7	2.3
TOTAL	BILLION \$	14.7	357.9	1,246.4	2,100.6	3,719.7	95.4

**TABLE 6.8.9 | INDIA: ACCUMULATED INVESTMENT COSTS FOR RENEWABLE HEAT GENERATION UNDER THE ADVANCED ENERGY [R]EVOLUTION SCENARIO COMPARED TO THE REFERENCE SCENARIO**

ACCUMULATED INVESTMENT COSTS DIFFERENCE REF MINUS ADVANCED E[R]	UNIT	2012-2020	2021-2030	2031-2040	2041-2050	2012-2050	2012 - 2050 AVERAGE PER YEAR
RENEWABLES	BILLION \$	-61.4	160.6	231.7	396.1	727.0	18.6

## 6.9 OTHER ASIA

### 6.9.1 FINAL ENERGY DEMAND BY SECTOR

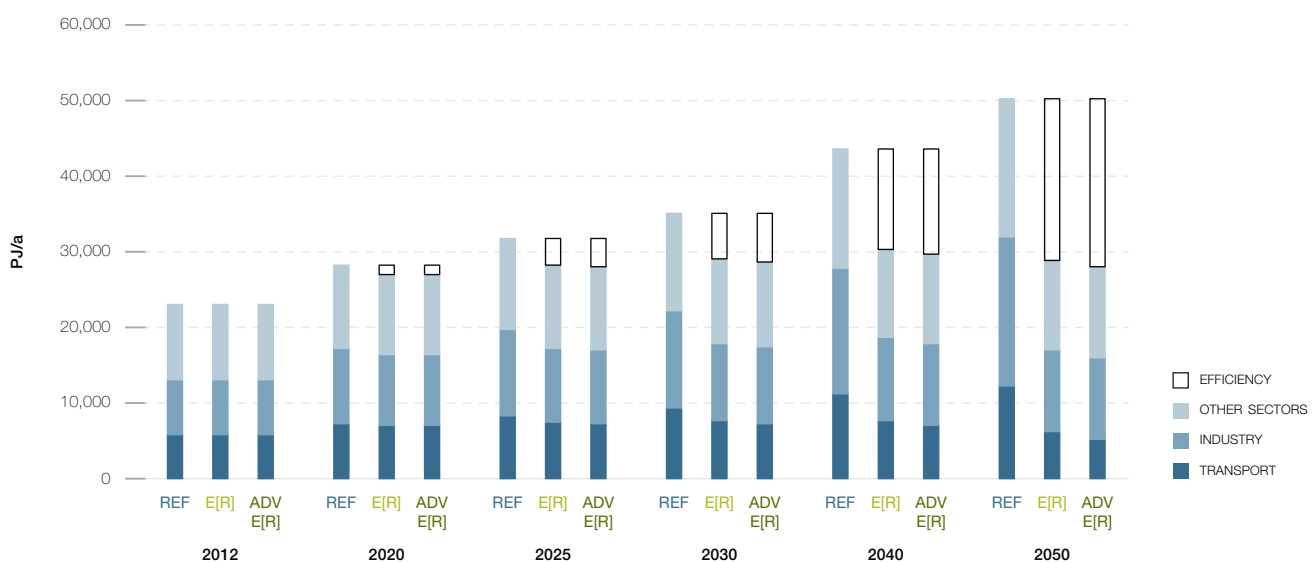
Combining the projections on population development, GDP growth and energy intensity results in future development pathways for Other Asia's final energy demand. These are shown in Figure 6.9.1 for the Reference and Energy [R]evolution scenarios. Under the Reference scenario, total final energy demand increases by 118% from the current 23,000 PJ/a to 50,200 PJ/a in 2050. In the basic Energy [R]evolution scenario, final energy demand increases at a much lower rate by 25% compared to current consumption and is expected to reach 28,800 PJ/a by 2050. The Advanced scenario results in some additional reductions due to a higher share of electric cars.

Under both Energy [R]evolution scenarios, due to economic growth, increasing living standards and electrification of the transport sector, overall electricity demand is expected to increase despite efficiency gains in all sectors (see Figure 6.9.2). Total electricity demand will rise from about 1,080 TWh/a to 3,680 TWh/a by 2050 in the basic Energy [R]evolution scenario. Compared to the Reference scenario, efficiency measures in the industry, residential and service sectors avoid the generation of about 1,730 TWh/a.

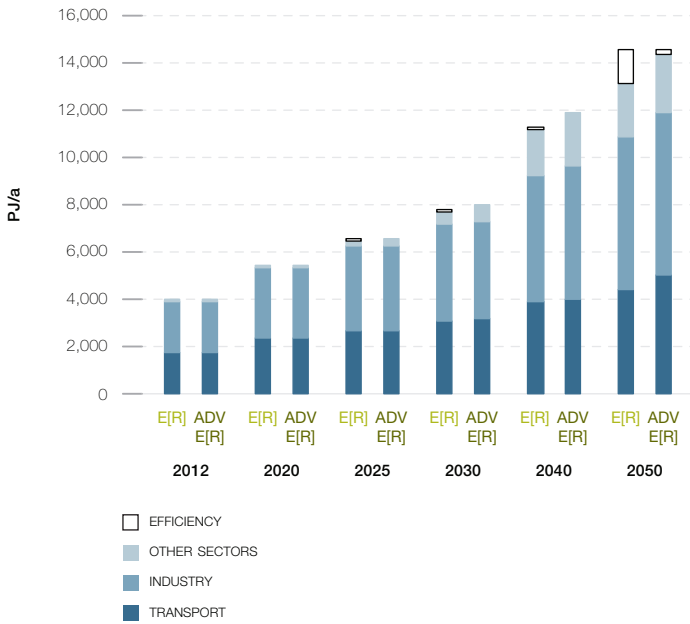
This reduction can be achieved in particular by introducing highly efficient electronic devices using the best available technology in all demand sectors. The transformation to a carbon free energy system in the Advanced scenario will further increase the electricity demand in 2050 up to 4,000 TWh/a. Electricity will become the major renewable 'primary' energy, not only for direct use for various purposes but also for the generation of synthetic fuels for fossil fuels substitution. Around 680 TWh are used in 2050 for electric vehicles and rail transport in 2050 in the Advanced scenario, around 630 TWh for hydrogen and 70 TWh for synthetic liquid fuel generation for the transport sector (excluding bunkers).

Efficiency gains in the heating sector are even larger than in the electricity sector. Under the Energy [R]evolution scenarios, consumption equivalent to about 6,100 PJ/a is avoided through efficiency gains by 2050 compared to the Reference scenario. As a result of energy-related renovation of the existing stock of residential buildings, the introduction of low energy standards and 'passive climatisation' for new buildings, as well as highly efficient air conditioning systems, enjoyment of the same comfort and energy services will be accompanied with much lower future energy demand.

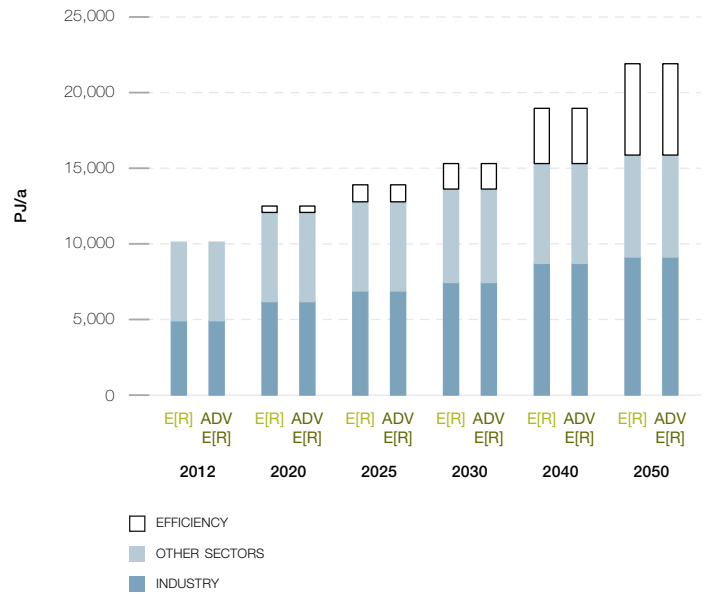
**FIGURE 6.9.1 | OTHER ASIA: PROJECTION OF TOTAL FINAL ENERGY DEMAND BY SECTOR – REFERENCE, ENERGY [R]EVOLUTION, ADVANCED ENERGY [R]EVOLUTION SCENARIOS** WITHOUT NON-ENERGY USE AND HEAT FROM CHP AUTOPRODUCERS



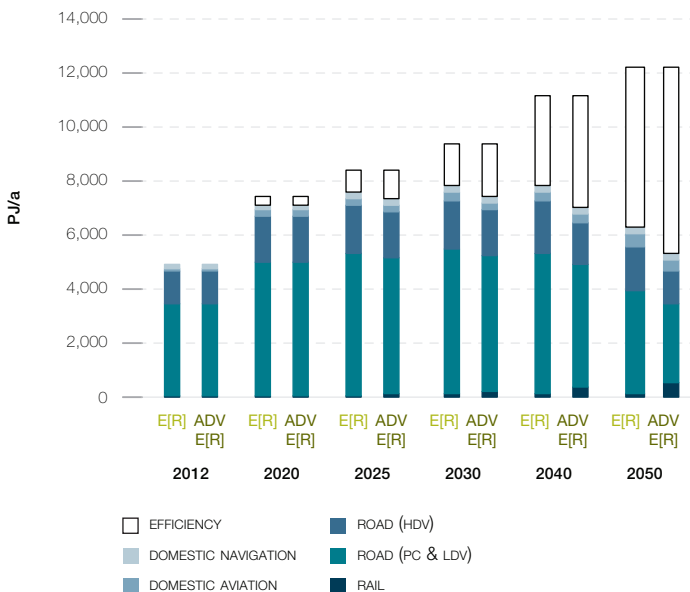
**FIGURE 6.9.2 | OTHER ASIA: DEVELOPMENT OF ELECTRICITY DEMAND BY SECTOR IN THE ENERGY [R]EVOLUTION SCENARIOS**



**FIGURE 6.9.4 | OTHER ASIA: DEVELOPMENT OF FINAL ENERGY DEMAND FOR HEAT BY SECTOR IN THE ENERGY [R]EVOLUTION SCENARIOS**



**FIGURE 6.9.3 | OTHER ASIA: DEVELOPMENT OF THE FINAL ENERGY DEMAND FOR TRANSPORT BY SECTOR IN THE ENERGY [R]EVOLUTION SCENARIOS**



### 6.9.2 ELECTRICITY GENERATION

The development of the electricity supply sector is characterised by a dynamically growing renewable energy market and an increasing share of renewable electricity. This trend will more than compensate for the phasing out of nuclear power production in the Energy [R]evolution scenarios, continuously reducing the number of fossil fuel-fired power plants as well. By 2050, 92% of the electricity produced in Other Asia will come from renewable energy sources in the basic Energy [R]evolution scenario. ‘New’ renewables – mainly wind, PV, CSP and geothermal energy – will contribute 73% to the total electricity generation. Already by 2020 the share of renewable electricity production will be 25% and 60% by 2030. The installed capacity of renewables will reach about 620 GW in 2030 and 1,930 GW by 2050.

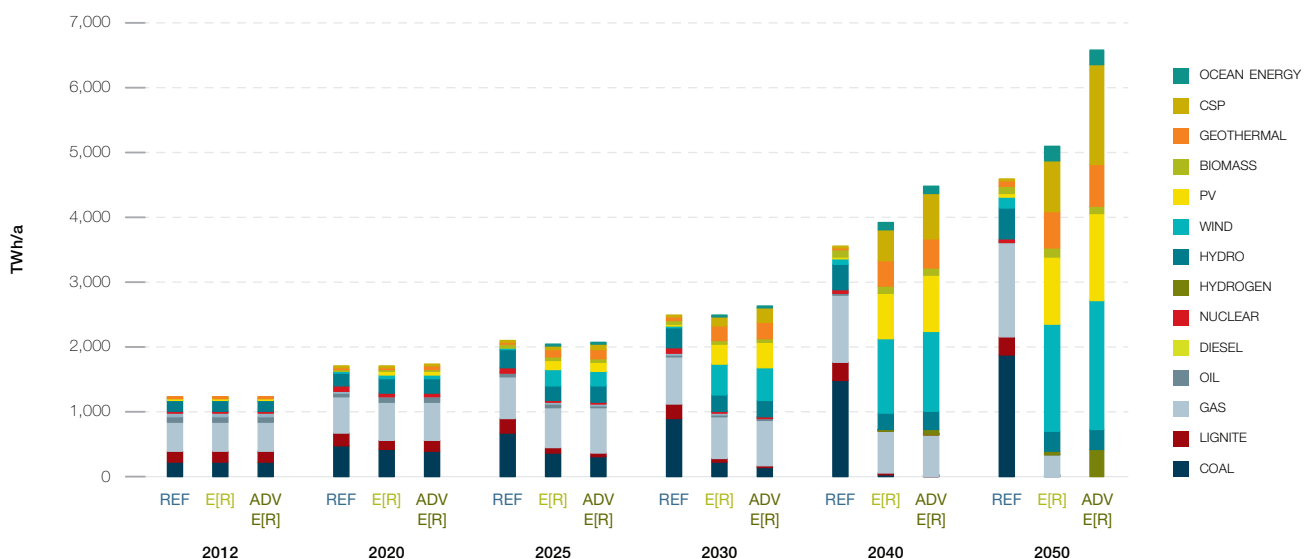
A 100% electricity supply from renewable energy resources in the Advanced scenario leads to around 2,450 GW installed generation capacity in 2050.

Table 6.9.1 shows the comparative evolution of the different renewable technologies in Other Asia over time. Up to 2020 wind and PV will become the main contributors to the growing market share. After 2020, the continuing growth of wind and PV will be complemented by electricity from solar thermal, geothermal and ocean energy. The Energy [R]evolution scenarios will lead to a high share of fluctuating power generation sources (PV, wind and ocean) of already 33% to 34% by 2030 and 57% to 54% by 2050. Therefore, smart grids, demand side management (DSM), energy storage capacities and other options need to be expanded in order to increase the flexibility of the power system for grid integration, load balancing and a secure supply of electricity.

**TABLE 6.9.1 | OTHER ASIA: PROJECTION OF RENEWABLE ELECTRICITY GENERATION CAPACITY UNDER THE REFERENCE AND THE ENERGY [R]EVOLUTION SCENARIOS** IN GW

		2012	2020	2030	2040	2050
HYDRO	REF	52	74	107	135	168
	E[R]	52	75	85	92	102
	ADV	52	75	86	93	102
BIOMASS	REF	5	10	14	19	26
	E[R]	5	11	16	26	35
	ADV	5	11	17	27	34
WIND	REF	1	5	16	34	62
	E[R]	1	33	196	443	645
	ADV	1	33	201	488	769
GEOTHERMAL	REF	3	4	6	8	11
	E[R]	3	5	32	61	83
	ADV	3	5	36	69	93
PV	REF	1	6	15	25	39
	E[R]	1	36	235	535	801
	ADV	1	36	290	665	1,030
CSP	REF	0	0	0	0	1
	E[R]	0	0	43	105	159
	ADV	0	0	61	150	311
OCEAN	REF	0	0	0	0	0
	E[R]	0	0	10	55	110
	ADV	0	0	10	55	110
TOTAL	REF	62	99	159	222	308
	E[R]	62	161	617	1,317	1,935
	ADV	62	161	702	1,547	2,450

**FIGURE 6.9.5 | OTHER ASIA: DEVELOPMENT OF ELECTRICITY GENERATION STRUCTURE – REFERENCE, ENERGY [R]EVOLUTION, ADVANCED ENERGY [R]EVOLUTION SCENARIOS**



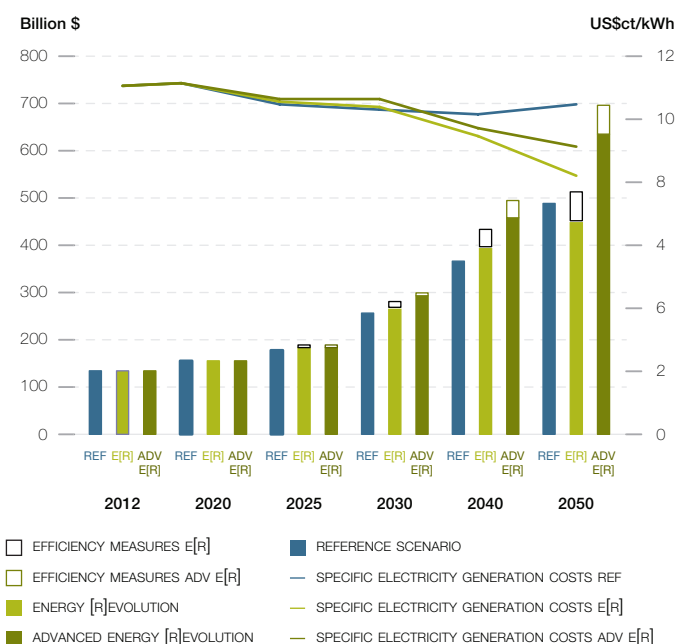
### 6.9.3 FUTURE COSTS OF ELECTRICITY GENERATION

Figure 6.9.6 shows that the introduction of renewable technologies under both Energy [R]evolution scenarios increases the future costs of electricity generation compared to the Reference scenario until 2030. This difference in full cost of generation will be less than 0.1 US\$ct/kWh in the basic Energy [R]evolution and about 0.4 US\$ct/kWh in the Advanced scenario, without taking into account integration costs for storage or other load-balancing measures. Because of increasing prices for conventional fuels, electricity generation costs will become economically favourable starting in 2030 under the Energy [R]evolution scenarios. By 2050, the cost will be 2.3/1.4 US\$ct/kWh, respectively, below those in the Reference case.

Under the Reference scenario, on the other hand, growth in demand and increasing fossil fuel prices result in total electricity supply costs rising from today's US\$ 136 billion per year to more than US\$ 488 billion in 2050, compared to US\$ 450 billion in the basic and US\$ 634 billion in the Advanced Energy [R]evolution scenario. Figure 6.9.6 shows that both Energy [R]evolution scenarios not only comply with Other Asia's CO<sub>2</sub> reduction targets, but also help stabilise energy costs and relieve the economic pressure on society.

Increasing energy efficiency and shifting energy supply to renewables lead to long term costs for electricity supply that are 8% higher in the basic Energy [R]evolution scenario than in the Reference scenario, due to a 12% increase in electricity production. The Advanced scenario with 100% renewable power and an increase in power generation of 44% results in supply costs 30% higher than the Reference case.

**FIGURE 6.9.6 | OTHER ASIA: DEVELOPMENT OF TOTAL ELECTRICITY SUPPLY COSTS & OF SPECIFIC ELECTRICITY GENERATION COSTS IN THE SCENARIOS**



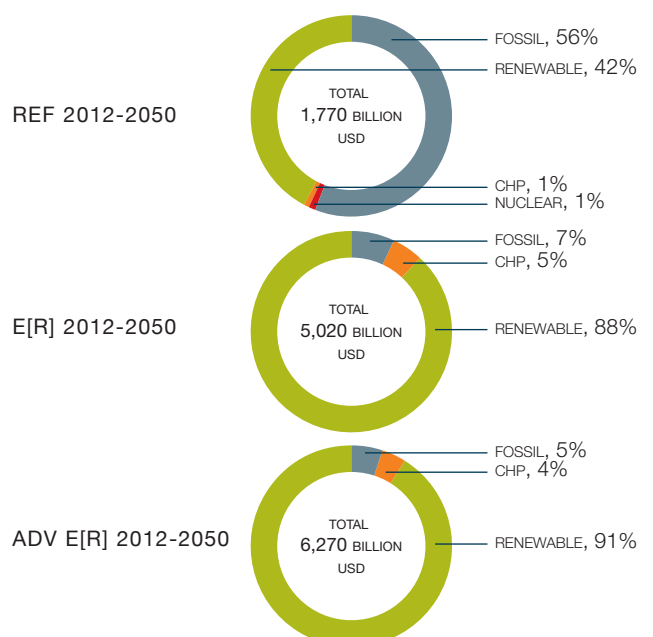
### 6.9.4 FUTURE INVESTMENTS IN THE POWER SECTOR

Around US\$ 5,020 billion is required in investment for the Energy [R]evolution scenario to become reality (including investments for replacement after the economic lifetime of the plants) - approximately US\$ 129 billion per year, US\$ 3,250 billion more than in the Reference scenario (US\$ 1,770 billion). Investments for the Advanced scenario add up to US\$ 6,270 billion until 2050, on average US\$ 161 billion per year, including high investments in additional power plants for the production of synthetic fuels. Under the Reference scenario, the levels of investment in conventional power plants add up to almost 57% while approximately 43% would be invested in renewable energies and cogeneration until 2050.

Under the Energy [R]evolution scenarios, however, Other Asia would shift almost 93%/95% of the entire investment towards renewables and cogeneration, respectively. By 2030, the fossil fuel share of power sector investment would be focused mainly on gas power plants.

Because renewable energy has no fuel costs, the fuel cost savings in the basic Energy [R]evolution scenario reach a total of US\$ 3,810 billion up to 2050, US\$ 98 billion per year. The total fuel cost savings therefore would cover 120% of the total additional investments compared to the Reference scenario. Fuel cost savings in the Advanced scenario are even higher and add up to US\$ 4,010 billion, or US\$ 103 billion per year. Renewable energy sources would then go on to produce electricity without any further fuel costs beyond 2050, while costs for coal and gas will continue to be a burden on national economies.

**FIGURE 6.9.7 | OTHER ASIA: INVESTMENT SHARES - REFERENCE VERSUS ENERGY [R]EVOLUTION SCENARIOS**



### 6.9.5 ENERGY SUPPLY FOR HEATING

Today, renewables meet around 42% of Other Asia’s energy demand for heat, the main contribution coming from the use of biomass. Dedicated support instruments are required to ensure a dynamic development in particular for renewable technologies for buildings and renewable process heat production. In the basic Energy [R]evolution scenario, renewables already provide 56% of Other Asia’s total heat demand in 2030 and 86% in 2050.

- Energy efficiency measures help to reduce the currently growing energy demand for heating by 28 % in 2050 (relative to the Reference scenario), in spite of improving living standards and economic growth.
- In the industry sector solar collectors, geothermal energy (incl. heat pumps) as well as electricity and hydrogen from renewable sources are increasingly substituting for fossil fuel-fired systems.
- A shift from coal and oil to natural gas in the remaining conventional applications leads to a further reduction of CO<sub>2</sub> emissions.

Table 6.9.2 shows the development of different renewable technologies for heating in Other Asia over time. Up to 2030 biomass remains the main contributor of the growing market share. After 2030, the continuing growth of solar collectors and a growing share of geothermal and environmental heat as well as heat from renewable hydrogen will further reduce the dependence on fossil fuels. The Advanced scenario results in a complete substitution of the remaining gas consumption by hydrogen generated from renewable electricity.

**TABLE 6.9.2 | OTHER ASIA: PROJECTION OF RENEWABLE HEAT SUPPLY UNDER THE REFERENCE AND BOTH ENERGY [R]EVOLUTION SCENARIOS** IN PJ/a

		2012	2020	2030	2040	2050
BIOMASS	REF	4,215	4,583	4,651	4,820	4,780
	E[R]	4,215	4,756	4,386	3,587	3,173
	ADV	4,215	4,756	4,386	3,658	3,353
SOLAR HEATING	REF	4	41	55	96	154
	E[R]	4	446	1,131	2,529	3,179
	ADV	4	446	1,131	2,529	3,703
GEOTHERMAL HEAT AND HEAT PUMPS	REF	0	0	0	0	0
	E[R]	0	545	1,068	2,049	3,287
	ADV	0	545	1,068	2,048	3,271
HYDROGEN	REF	0	0	0	0	0
	E[R]	0	0	0	17	657
	ADV	0	0	0	358	1,431
TOTAL	REF	4,219	4,624	4,706	4,916	4,934
	E[R]	4,219	5,747	6,585	8,182	10,296
	ADV	4,219	5,747	6,585	8,593	11,759

**FIGURE 6.9.8 | OTHER ASIA: PROJECTION OF HEAT SUPPLY BY ENERGY CARRIER – REFERENCE, ENERGY [R]EVOLUTION, ADVANCED ENERGY [R]EVOLUTION SCENARIOS**





### 6.9.6 FUTURE INVESTMENTS IN THE HEATING SECTOR

Also in the heating sector the Energy [R]evolution scenarios would require a major revision of current investment strategies in heating technologies. In particular, solar thermal, geothermal and heat pump technologies need an enormous increase in installations if these potentials are to be tapped for the heating sector. The use of biomass for heating purposes - often traditional biomass today - will be substantially reduced in the Energy [R]evolution scenarios and replaced by more efficient and sustainable renewable heating technologies.

Renewable heating technologies are extremely variable, from low tech biomass stoves and unglazed solar collectors to very sophisticated enhanced geothermal and solar systems. Thus, it can only be roughly estimated that the Energy [R]evolution scenario in total requires around US\$ 1,490 billion to be invested in renewable heating technologies up to 2050 (including investments for replacement after the economic lifetime of the plants) - approximately US\$ 38 billion per year. The Advanced scenario assumes an even more ambitious expansion of renewable technologies resulting in an average investment of around US\$ 41 billion per year, while the main strategy in the scenario is the substitution of the remaining natural gas amounts with hydrogen or other synthetic fuels.

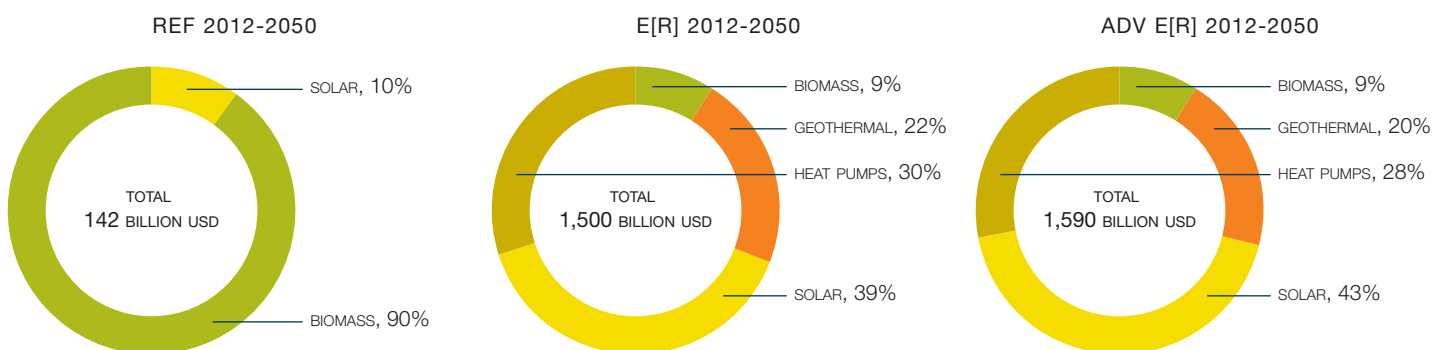
**TABLE 6.9.3 | OTHER ASIA: INSTALLED CAPACITIES FOR RENEWABLE HEAT GENERATION UNDER THE SCENARIOS**

IN GW

		2012	2020	2030	2040	2050
BIOMASS	REF	1,971	1,947	1,848	1,737	1,565
	E[R]	1,971	2,081	1,696	1,263	941
	ADV	1,971	2,081	1,696	1,294	986
GEOTHERMAL	REF	0	0	0	0	0
	E[R]	0	17	45	88	117
	ADV	0	17	45	88	116
SOLAR HEATING	REF	1	8	17	30	48
	E[R]	1	33	349	780	981
	ADV	1	33	349	780	1,143
HEAT PUMPS	REF	0	0	0	0	0
	E[R]	0	0	64	119	221
	ADV	0	0	64	119	220
TOTAL*	REF	1,973	1,955	1,865	1,767	1,613
	E[R]	1,973	2,131	2,154	2,250	2,260
	ADV	1,973	2,131	2,154	2,281	2,465

\* Excluding direct electric heating.

**FIGURE 6.9.9 | OTHER ASIA: DEVELOPMENT OF INVESTMENTS FOR RENEWABLE HEAT GENERATION TECHNOLOGIES – REFERENCE, ENERGY [R]EVOLUTION, ADVANCED ENERGY [R]EVOLUTION SCENARIOS**



### 6.9.7 FUTURE EMPLOYMENT IN THE ENERGY SECTOR

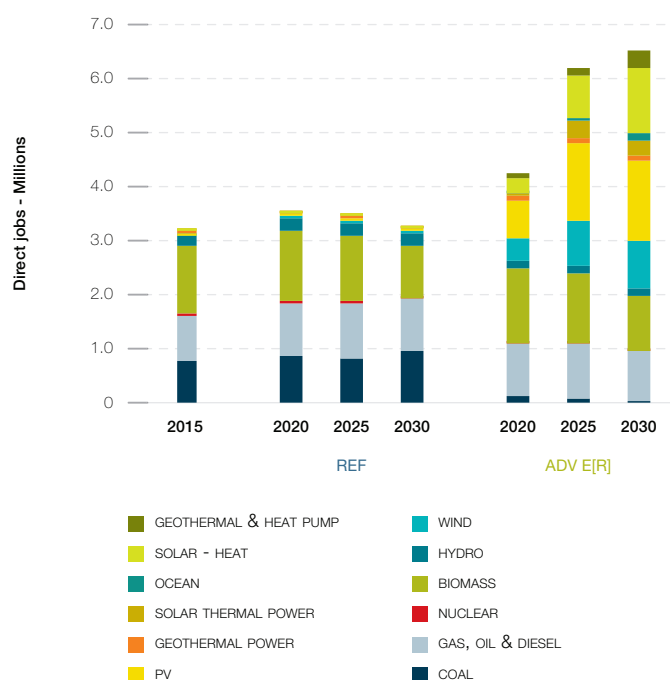
The Advanced Energy [R]evolution scenario results in more energy sector jobs in Developing Asia at every stage of the projection.

- There are 4.3 million energy sector jobs in the Advanced Energy [R]evolution in 2020, and 3.6 million in the Reference scenario.
- In 2025, there are 6.2 million jobs in the Advanced Energy [R]evolution scenario, and 3.5 million in the Reference scenario.
- In 2030, there are 6.5 million jobs in the Advanced Energy [R]evolution scenario and 3.3 million in the Reference scenario.

Figure 6.9.10 shows the change in job numbers under both scenarios for each technology between 2015 and 2030. Jobs in the Reference scenario remain fairly stable after 2020, and are 2% above 2015 levels at 2030.

Strong growth in renewable energy in the Advanced Energy [R]evolution scenario offsets the virtual disappearance of coal and leads to an increase of 33% in total energy sector jobs by 2020. Continued growth leads to energy jobs reaching double 2015 levels in 2030. Renewable energy accounts for 85% of energy sector jobs in 2030, with solar PV having the largest share (23%), followed by solar heating and then biomass.

**FIGURE 6.9.10 | OTHER ASIA: EMPLOYMENT IN THE ENERGY SECTOR UNDER THE REFERENCE AND ADVANCED ENERGY [R]EVOLUTION SCENARIO**



**TABLE 6.9.4 | OTHER ASIA: TOTAL EMPLOYMENT IN THE ENERGY SECTOR IN THOUSAND JOBS**

	2015	2020	REFERENCE		ADVANCED ENERGY [R]EVOLUTION		
			2025	2030	2020	2025	2030
COAL	783	870	816	946	90	126	45
GAS, OIL & DIESEL	811	963	1,019	964	987	950	905
NUCLEAR	38	37	31	28.1	19.8	20.0	16.7
RENEWABLES	1,578	1,697	1,610	1,329	5,112	3,166	5,562
<b>TOTAL JOBS</b>	<b>3,209</b>	<b>3,567</b>	<b>3,476</b>	<b>3,267</b>	<b>6,208</b>	<b>4,262</b>	<b>6,528</b>
CONSTRUCTION AND INSTALLATION	671	749	670	708	2,328	1,154	2,579
MANUFACTURING	306	350	320	350	1,045	488	1,277
OPERATIONS AND MAINTENANCE	349	433	484	467	849	547	1,105
FUEL SUPPLY (DOMESTIC)	1,812	1,985	1,980	1,742	1,963	2,020.6	1,568
COAL AND GAS EXPORT	71	50	22	-	23	52	-
<b>TOTAL JOBS</b>	<b>3,209</b>	<b>3,567</b>	<b>3,476</b>	<b>3,267</b>	<b>6,208</b>	<b>4,262</b>	<b>6,528</b>

### 6.9.8 TRANSPORT

In 2050, the car fleet in Other Asia will be significantly larger than today. Therefore a key target is the successful introduction of highly efficient vehicle concepts. In addition, it is vital to shift transport use to efficient modes like rail, light rail and buses, especially in the expanding large metropolitan areas. Along with rising prices for fossil fuels, these changes reduce the further growth in car sales projected under the Reference scenario. Due to population increase, GDP growth and higher living standards, energy demand from the transport sector is expected to strongly increase in the Reference scenario by around 108% to 12,220 PJ/a in 2050. In the basic Energy [R]evolution scenario, efficiency measures and modal shifts will save 49% (5,940 PJ/a) in 2050 compared to the Reference scenario.

Additional modal shifts and technology switches lead to even higher energy savings in the Advanced scenario of 57% (6,920 PJ/a) in 2050 compared to the Reference scenario. Highly efficient propulsion technology with hybrid, plug-in hybrid and battery-electric power trains will bring about large efficiency gains. By 2030, electricity will provide 7% of the transport sector's total energy demand in the Energy [R]evolution, while in 2050 the share will be 36% (46% in the Advanced scenario). Hydrogen and other synthetic fuels generated using renewable electricity are complementary options to further increase the renewable share in the transport sector. In 2050, up to 1,750 PJ/a of hydrogen is used in the transport sector for the Advanced Energy [R]evolution scenario.

**TABLE 6.9.5 | OTHER ASIA: PROJECTION OF TRANSPORT ENERGY DEMAND BY MODE IN THE REFERENCE AND THE ENERGY [R]EVOLUTION SCENARIOS** IN PJ/a

		2012	2020	2030	2040	2050
RAIL	REF	65	105	122	159	199
	E[R]	65	83	108	136	160
	ADV	65	83	237	408	559
ROAD	REF	5,471	7,738	8,601	10,138	10,927
	E[R]	5,471	6,650	7,202	7,129	5,398
	ADV	5,471	6,650	6,676	6,098	4,126
DOMESTIC AVIATION	REF	172	318	384	507	652
	E[R]	172	212	264	345	499
	ADV	172	212	256	321	399
DOMESTIC NAVIGATION	REF	177	264	300	372	444
	E[R]	177	200	235	213	221
	ADV	177	200	235	213	221
TOTAL	REF	5,886	8,425	9,407	11,177	12,222
	E[R]	5,886	7,144	7,808	7,824	6,278
	ADV	5,886	7,144	7,403	7,040	5,305

6

**FIGURE 6.9.11 | OTHER ASIA: FINAL ENERGY CONSUMPTION IN TRANSPORT UNDER THE SCENARIOS**



### 6.9.10 DEVELOPMENT OF CO<sub>2</sub> EMISSIONS

Whilst Other Asia's emissions of CO<sub>2</sub> will increase by 173% between 2012 and 2050 under the Reference scenario, under the Energy [R]evolution scenario they will decrease from 1,740 million tonnes in 2012 to 338 million tonnes in 2050. Annual per capita emissions will drop from 1.6 tonne to 0.2 tonne. In spite of the abstinence of nuclear power production and increasing power demand, CO<sub>2</sub> emissions will decrease in the electricity sector. In the long run efficiency gains and the increased use of renewable electricity in vehicles strongly reduce emissions in the transport sector as well.

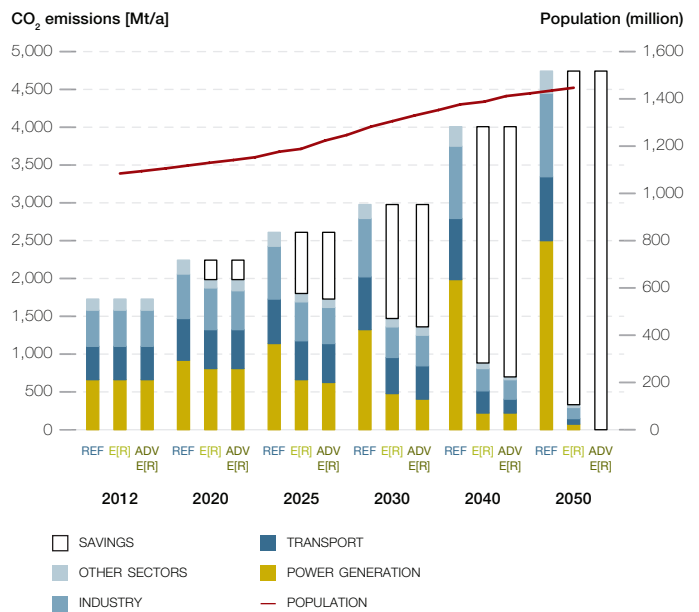
With a 39% share of CO<sub>2</sub>, the Industry sector will be the largest source of emissions in 2050 in the basic Energy [R]evolution scenario. By 2050, Other Asia's CO<sub>2</sub> emissions are around 52% below 1990 levels in the Energy [R]evolution scenario while energy consumption is fully decarbonised in the Advanced case.

### 6.9.11 PRIMARY ENERGY CONSUMPTION

Taking into account the assumptions discussed above, the resulting primary energy consumption under the Energy [R]evolution scenarios is shown in Figure 6.9.12. Under the basic Energy [R]evolution scenario, primary energy demand will increase by 29% from today's 35,530 PJ/a to around 46,000 PJ/a. Compared to the Reference scenario, overall primary energy demand will be reduced by 43% in 2050 under the Energy [R]evolution scenario (Reference scenario: around 80,000 PJ in 2050). The Advanced scenario results due to additional conversion losses in a primary energy consumption of around 46,900 PJ in 2050.

The Energy [R]evolution scenarios aim to phase out coal and oil as fast as technically and economically possible by

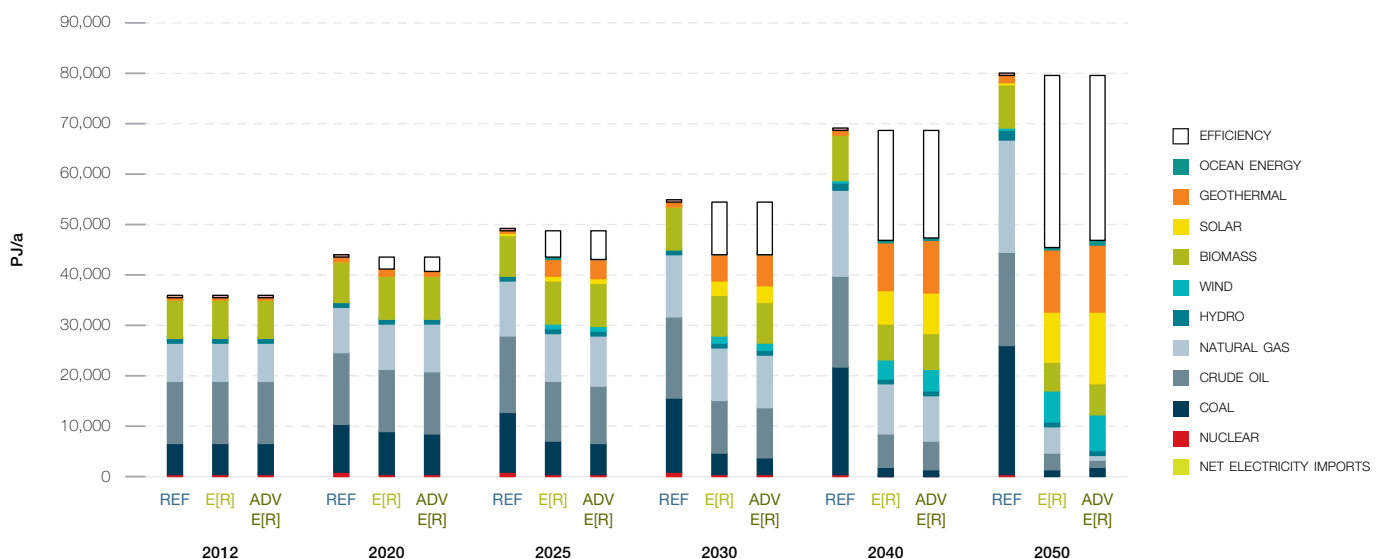
**FIGURE 6.9.13 | OTHER ASIA: DEVELOPMENT OF CO<sub>2</sub> EMISSIONS BY SECTOR UNDER THE ENERGY [R]EVOLUTION SCENARIOS** 'SAVINGS' = REDUCTION COMPARED TO THE REFERENCE SCENARIO



expansion of renewable energies and a fast introduction of very efficient vehicle concepts in the transport sector to replace oil based combustion engines. This leads to an overall renewable primary energy share of 43% in 2030 and 79% in 2050 in the basic Energy [R]evolution and of more than 91% in 2050 in the Advanced case (incl. non-energy consumption). In contrast to the Reference scenario, no new nuclear power plants will be built in Other Asia in the Energy [R]evolution scenarios.

**FIGURE 6.9.12 | OTHER ASIA: PROJECTION OF TOTAL PRIMARY ENERGY DEMAND (PED) BY ENERGY CARRIER**

INCLUDING ELECTRICITY IMPORT BALANCE – REFERENCE, ENERGY [R]EVOLUTION, ADVANCED ENERGY [R]EVOLUTION SCENARIOS



**TABLE 6.9.6 | OTHER ASIA: ACCUMULATED INVESTMENT COSTS FOR ELECTRICITY GENERATION AND FUEL COST SAVINGS UNDER THE ENERGY [R]EVOLUTION SCENARIO COMPARED TO THE REFERENCE SCENARIO**

ACCUMULATED INVESTMENT COSTS DIFFERENCE REF MINUS E[R]	UNIT	2012-2020	2021-2030	2031-2040	2041-2050	2012-2050	2012 - 2050 AVERAGE PER YEAR
CONVENTIONAL (FOSSIL + NUCLEAR)	BILLION \$	54.7	157.1	209.5	235.9	657.1	16.8
RENEWABLES (INCL. CHP)	BILLION \$	-114.1	-961.0	-1,352.7	-1,487.3	-3,915.1	-100.4
TOTAL	BILLION \$	-59.4	-803.9	-1,143.2	-1,251.5	-3,258.0	-83.5
<b>ACCUMULATED FUEL COST SAVINGS</b>							
SAVINGS CUMULATIVE E[R] VERSUS REF							
FUEL OIL	BILLION \$	0.7	24.1	39.5	20.0	84.3	2.2
GAS	BILLION \$	-8.9	109.8	513.1	1,278.6	1,892.6	48.5
HARD COAL	BILLION \$	8.4	191.0	567.9	894.2	1,661.5	42.6
LIGNITE	BILLION \$	1.7	25.6	46.6	62.9	136.9	3.5
NUCLEAR ENERGY	BILLION \$	1.6	7.9	10.5	12.8	32.8	0.8
TOTAL	BILLION \$	3.5	358.4	1,177.5	2,268.5	3,808.0	97.6

**TABLE 6.9.7 | OTHER ASIA: ACCUMULATED INVESTMENT COSTS FOR RENEWABLE HEAT GENERATION UNDER THE ENERGY [R]EVOLUTION SCENARIO COMPARED TO THE REFERENCE SCENARIO**

ACCUMULATED INVESTMENT COSTS DIFFERENCE REF MINUS E[R]	UNIT	2012-2020	2021-2030	2031-2040	2041-2050	2012-2050	2012 - 2050 AVERAGE PER YEAR
RENEWABLES	BILLION \$	125.4	312.7	376.5	538.7	1,353.3	34.7

**TABLE 6.9.8 | OTHER ASIA: ACCUMULATED INVESTMENT COSTS FOR ELECTRICITY GENERATION AND FUEL COST SAVINGS UNDER THE ADVANCED ENERGY [R]EVOLUTION SCENARIO COMPARED TO THE REFERENCE SCENARIO**

ACCUMULATED INVESTMENT COSTS DIFFERENCE REF MINUS ADVANCED E[R]	UNIT	2012-2020	2021-2030	2031-2040	2041-2050	2012-2050	2012 - 2050 AVERAGE PER YEAR
CONVENTIONAL (FOSSIL + NUCLEAR)	BILLION \$	56.2	166.8	204.1	249.5	676.6	17.3
RENEWABLES (INCL. CHP)	BILLION \$	-115.0	-1,169.1	-1,630.9	-2,262.4	-5,177.4	-132.8
TOTAL	BILLION \$	-58.8	-1,002.3	-1,426.8	-2,012.9	-4,500.9	-115.4
<b>ACCUMULATED FUEL COST SAVINGS</b>							
SAVINGS CUMULATIVE ADVANCED E[R] VERSUS REF							
FUEL OIL	BILLION \$	0.7	28.8	44.7	23.1	97.3	2.5
GAS	BILLION \$	-14.6	69.0	500.2	1,468.9	2,023.5	51.9
HARD COAL	BILLION \$	10.3	217.4	593.2	899.7	1,720.5	44.1
LIGNITE	BILLION \$	1.7	25.6	46.6	63.1	137.1	3.5
NUCLEAR ENERGY	BILLION \$	1.6	7.9	10.5	12.8	32.8	0.8
TOTAL	BILLION \$	-0.3	348.7	1,195.1	2,467.6	4,011.1	102.8

**TABLE 6.9.9 | OTHER ASIA: ACCUMULATED INVESTMENT COSTS FOR RENEWABLE HEAT GENERATION UNDER THE ADVANCED ENERGY [R]EVOLUTION SCENARIO COMPARED TO THE REFERENCE SCENARIO**

ACCUMULATED INVESTMENT COSTS DIFFERENCE REF MINUS ADVANCED E[R]	UNIT	2012-2020	2021-2030	2031-2040	2041-2050	2012-2050	2012 - 2050 AVERAGE PER YEAR
RENEWABLES	BILLION \$	125.6	312.6	375.6	637.0	1,450.8	37.2

## 6.10 CHINA

### 6.10.1 FINAL ENERGY DEMAND BY SECTOR

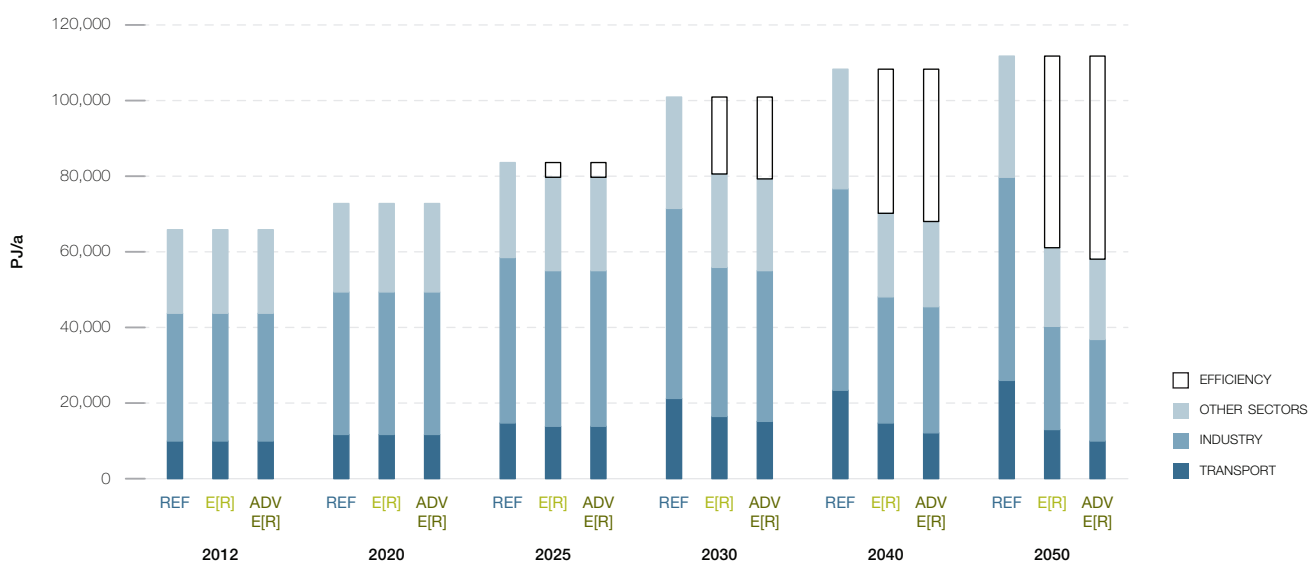
Combining the projections on population development, GDP growth and energy intensity results in future development pathways for China's final energy demand. These are shown in Figure 6.10.1 for the Reference and Energy [R]evolution scenarios. Under the Reference scenario, total final energy demand increases by 70% from the current 65,900 PJ/a to 111,800 PJ/a in 2050. In the basic Energy [R]evolution scenario, final energy demand decreases by 7% compared to current consumption and is expected to reach 61,000 PJ/a by 2050. The Advanced scenario results in some additional reductions due to a higher share of electric cars.

Under both Energy [R]evolution scenarios, due to economic growth, increasing living standards and electrification of the transport sector, overall electricity demand is expected to increase despite efficiency gains in all sectors (see Figure 6.10.2). Total electricity demand will rise from about 4,170 TWh/a to 8,730 TWh/a by 2050 in the basic Energy [R]evolution scenario. Compared to the Reference scenario, efficiency measures in the industry, residential and service sectors avoid the generation of about 4,760 TWh/a.

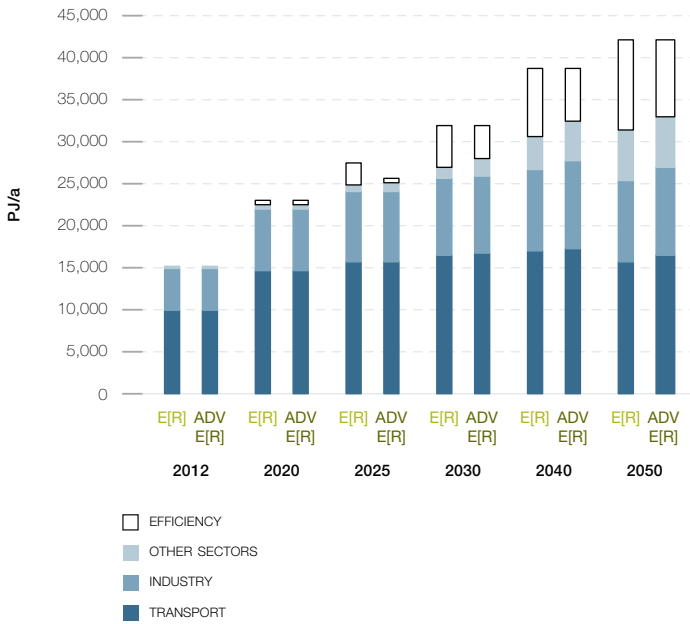
This reduction can be achieved in particular by introducing highly efficient electronic devices using the best available technology in all demand sectors. The transformation to a carbon free energy system in the Advanced scenario will further increase the electricity demand in 2050 up to 9,200 TWh/a. Electricity will become the major renewable 'primary' energy, not only for direct use for various purposes but also for the generation of synthetic fuels for fossil fuels substitution. Around 1,710 TWh are used in 2050 for electric vehicles and rail transport in 2050 in the Advanced scenario, around 500 TWh for hydrogen and 950 TWh for synthetic liquid fuel generation for the transport sector (excluding bunkers).

Efficiency gains in the heating sector are very large as well. Under the Energy [R]evolution scenarios, consumption equivalent to about 15,500 PJ/a is avoided through efficiency gains by 2050 compared to the Reference scenario. As a result of energy-related renovation of the existing stock of residential buildings, the introduction of low energy standards and 'passive climatisation' for new buildings, as well as highly efficient air conditioning systems, enjoyment of the same comfort and energy services will be accompanied with much lower future energy demand.

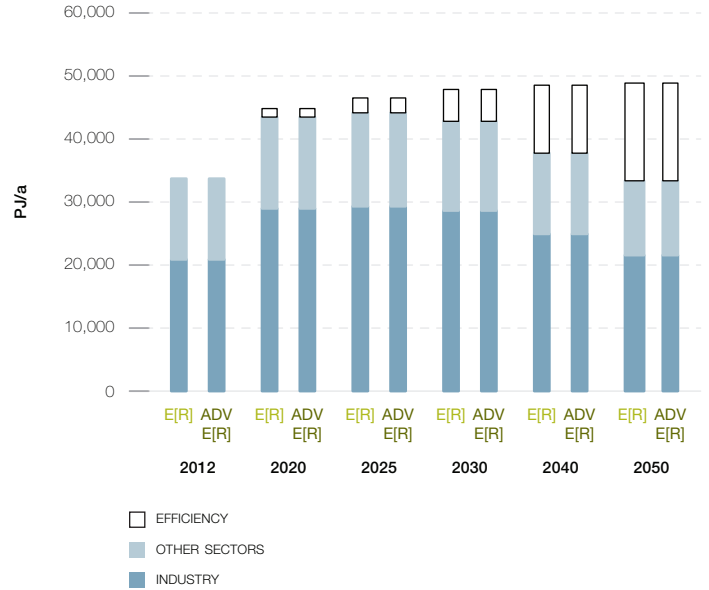
**FIGURE 6.10.1 | CHINA: PROJECTION OF TOTAL FINAL ENERGY DEMAND BY SECTOR - REFERENCE, ENERGY [R]EVOLUTION, ADVANCED ENERGY [R]EVOLUTION SCENARIOS** WITHOUT NON-ENERGY USE AND HEAT FROM CHP AUTOPRODUCERS



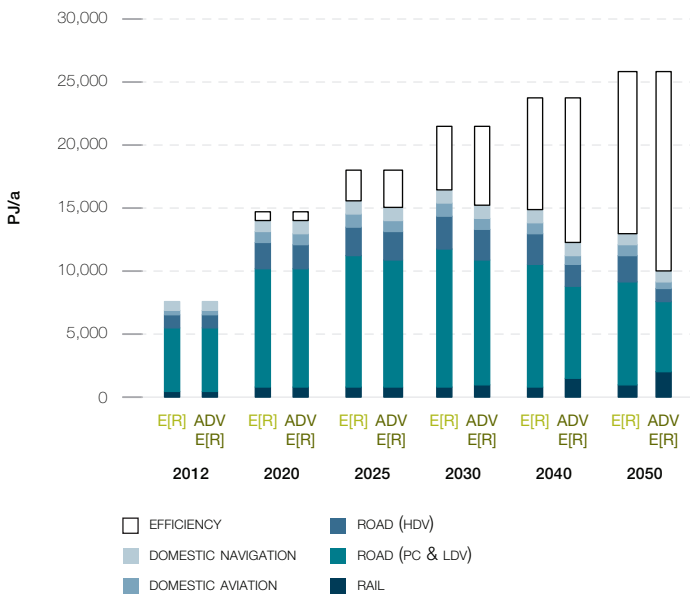
**FIGURE 6.10.2 | CHINA: DEVELOPMENT OF ELECTRICITY DEMAND BY SECTOR IN THE ENERGY [R]EVOLUTION SCENARIOS**



**FIGURE 6.10.4 | CHINA: DEVELOPMENT OF FINAL ENERGY DEMAND FOR HEAT BY SECTOR IN THE ENERGY [R]EVOLUTION SCENARIOS**



**FIGURE 6.10.3 | CHINA: DEVELOPMENT OF THE FINAL ENERGY DEMAND FOR TRANSPORT BY SECTOR IN THE ENERGY [R]EVOLUTION SCENARIOS**



### 6.10.2 ELECTRICITY GENERATION

The development of the electricity supply sector is characterised by a dynamically growing renewable energy market and an increasing share of renewable electricity. This trend will more than compensate for the phasing out of nuclear power production in the Energy [R]evolution scenarios, continuously reducing the number of fossil fuel-fired power plants as well. By 2050, 87% of the electricity produced in China will come from renewable energy sources in the basic Energy [R]evolution scenario. ‘New’ renewables – mainly wind, PV, CSP and geothermal energy – will contribute 58% to the total electricity generation. Already by 2020 the share of renewable electricity production will be 26% and 44% by 2030. The installed capacity of renewables will reach about 1,520 GW in 2030 and 3,410 GW by 2050.

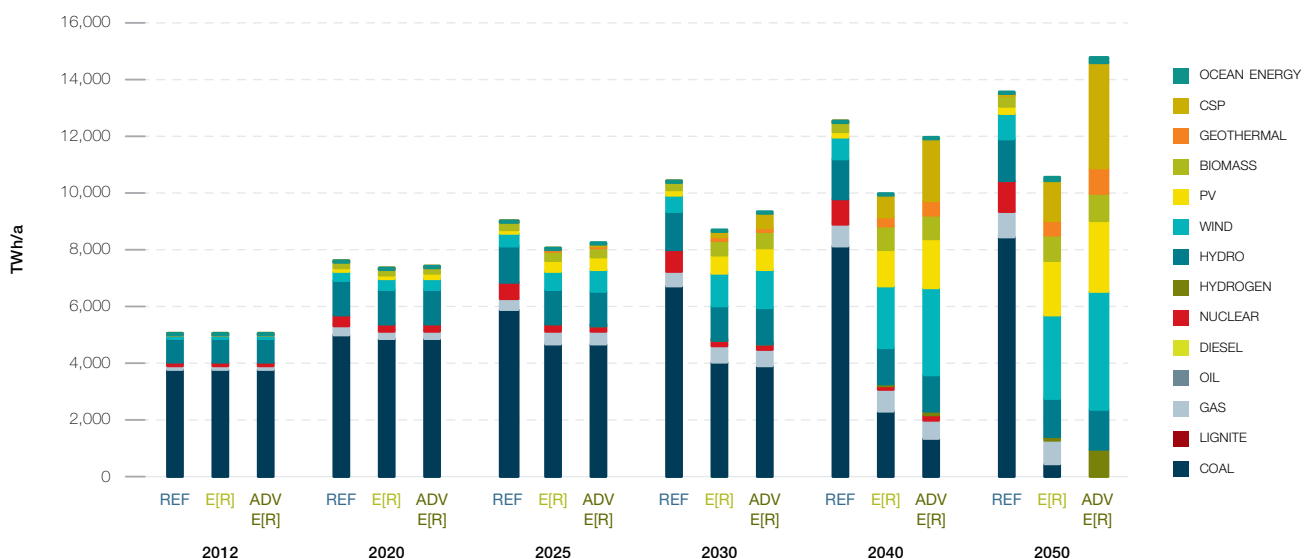
A 100% electricity supply from renewable energy resources in the Advanced scenario leads to around 4,740 GW installed generation capacity in 2050.

Table 6.10.1 shows the comparative evolution of the different renewable technologies in China over time. Up to 2020 wind and PV will become the main contributors to the growing market share. After 2020, the continuing growth of wind and PV will be complemented by electricity from solar thermal, geothermal and ocean energy. The Energy [R]evolution scenarios will lead to a high share of fluctuating power generation sources (PV, wind and ocean) of already 21% to 23% by 2030 and up to 47% by 2050. Therefore, smart grids, demand side management (DSM), energy storage capacities and other options need to be expanded in order to increase the flexibility of the power system for grid integration, load balancing and a secure supply of electricity.

**TABLE 6.10.1 | CHINA: PROJECTION OF RENEWABLE ELECTRICITY GENERATION CAPACITY UNDER THE REFERENCE AND THE ENERGY [R]EVOLUTION SCENARIOS** IN GW

		2012	2020	2030	2040	2050
HYDRO	REF	249	360	406	434	461
	E[R]	249	360	381	399	418
	ADV	249	360	381	399	427
BIOMASS	REF	6	30	46	55	64
	E[R]	6	31	106	164	194
	ADV	6	31	106	164	203
WIND	REF	75	183	269	312	362
	E[R]	75	195	498	884	1,181
	ADV	75	205	582	1,220	1,604
GEOTHERMAL	REF	0	0	0	1	2
	E[R]	0	0	13	53	81
	ADV	0	0	19	79	137
PV	REF	7	81	124	155	186
	E[R]	7	131	483	892	1,232
	ADV	7	146	612	1,208	1,626
CSP	REF	0	0	1	5	10
	E[R]	0	0	39	154	249
	ADV	0	1	114	429	678
OCEAN	REF	0	0	0	1	1
	E[R]	0	0	4	21	52
	ADV	0	0	5	27	62
TOTAL	REF	337	655	847	962	1,087
	E[R]	337	718	1,523	2,565	3,407
	ADV	337	744	1,819	3,525	4,736

**FIGURE 6.10.5 | CHINA: DEVELOPMENT OF ELECTRICITY GENERATION STRUCTURE – REFERENCE, ENERGY [R]EVOLUTION, ADVANCED ENERGY [R]EVOLUTION SCENARIOS**





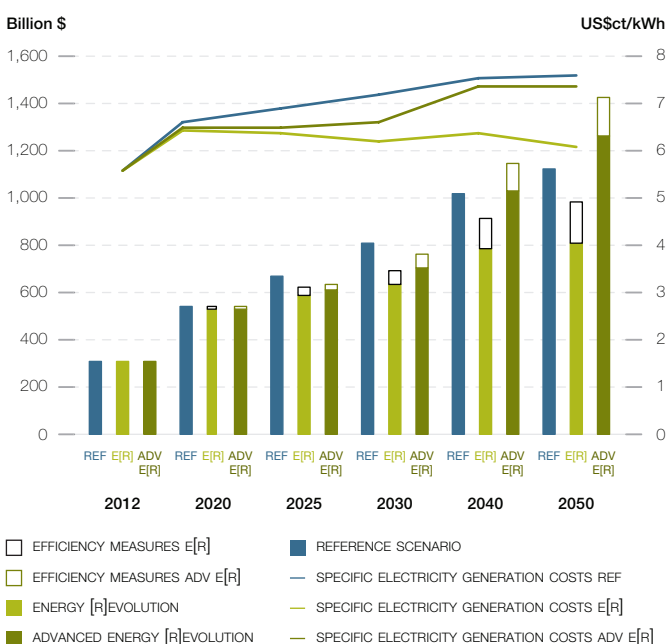
### 6.10.3 FUTURE COSTS OF ELECTRICITY GENERATION

Figure 6.10.6 shows that the introduction of renewable technologies under both Energy [R]evolution scenarios decreases the future costs of electricity generation compared to the Reference scenario already by 2020. This difference in full cost of generation will be in 2030 already 1.0 US\$ct/kWh in the basic Energy [R]evolution and 0.6 US\$ct/kWh in the Advanced scenario, without taking into account integration costs for storage or other load-balancing measures. Because of increasing prices for conventional fuels, electricity generation costs will become economically favourable starting in 2020 under the Energy [R]evolution scenarios. By 2050, the cost will be 1.5/0.2 US\$ct/kWh, respectively, below those in the Reference case.

Under the Reference scenario, on the other hand, growth in demand and increasing fossil fuel prices result in total electricity supply costs rising from today's US\$ 311 billion per year to more than US\$ 1,125 billion in 2050, compared to US\$ 813 billion in the basic and US\$ 1,268 billion in the Advanced Energy [R]evolution scenario. Figure 6.10.6 shows that both Energy [R]evolution scenarios not only comply with China's CO<sub>2</sub> reduction targets, but also help stabilise energy costs and relieve the economic pressure on society.

Increasing energy efficiency and shifting energy supply to renewables lead to long term costs for electricity supply that are more than 28% lower in the basic Energy [R]evolution scenario than in the Reference scenario. The Advanced scenario with 100% renewable power and an increase in power generation of 10% results in supply costs 13% higher than the Reference case.

**FIGURE 6.10.6 | CHINA: DEVELOPMENT OF TOTAL ELECTRICITY SUPPLY COSTS & OF SPECIFIC ELECTRICITY GENERATION COSTS IN THE SCENARIOS**



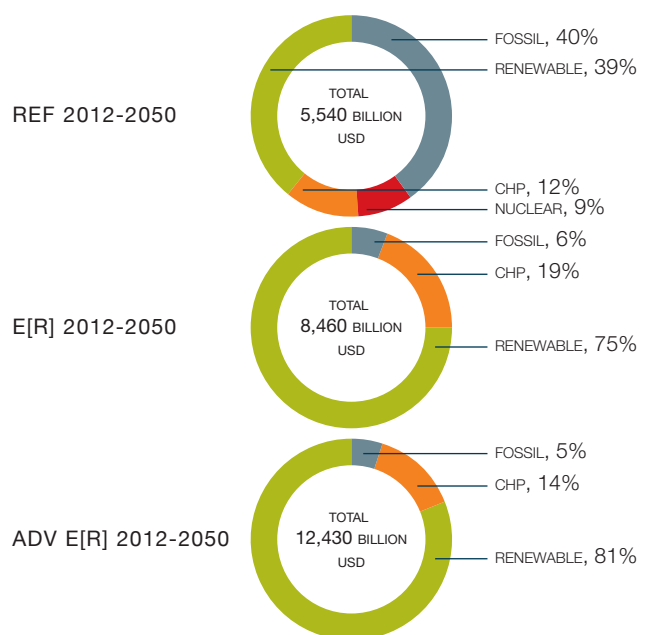
### 6.10.4 FUTURE INVESTMENTS IN THE POWER SECTOR

Around US\$ 8,470 billion is required in investment for the Energy [R]evolution scenario to become reality (including investments for replacement after the economic lifetime of the plants) - approximately US\$ 217 billion per year, US\$ 3,130 billion more than in the Reference scenario (US\$ 5,340 billion). Investments for the Advanced scenario add up to US\$ 12,430 billion until 2050, on average US\$ 319 billion per year, including high investments in additional power plants for the production of synthetic fuels. Under the Reference scenario, the levels of investment in conventional power plants add up to almost 49% while approximately 51% would be invested in renewable energies and cogeneration until 2050.

Under the Energy [R]evolution scenarios, however, China would shift up to 95% of the entire investment towards renewables and cogeneration, respectively. By 2030, the fossil fuel share of power sector investment would be focused mainly on gas power plants.

Because renewable energy has no fuel costs, the fuel cost savings in the basic Energy [R]evolution scenario reach a total of US\$ 8,840 billion up to 2050, US\$ 227 billion per year. The total fuel cost savings therefore would cover 280% of the total additional investments compared to the Reference scenario. Fuel cost savings in the Advanced scenario are even higher and add up to US\$ 9,610 billion, or US\$ 246 billion per year. Renewable energy sources would then go on to produce electricity without any further fuel costs beyond 2050, while costs for coal and gas will continue to be a burden on national economies.

**FIGURE 6.10.7 | CHINA: INVESTMENT SHARES - REFERENCE VERSUS ENERGY [R]EVOLUTION SCENARIOS**



### 6.10.5 ENERGY SUPPLY FOR HEATING

Today, renewables meet around 19% of China's energy demand for heating, the main contribution coming from the use of biomass. Dedicated support instruments are required to ensure a dynamic development in particular for renewable technologies for buildings and renewable process heat production. In the basic Energy [R]evolution scenario, renewables already provide 34% of China's total heat demand in 2030 and 82% in 2050.

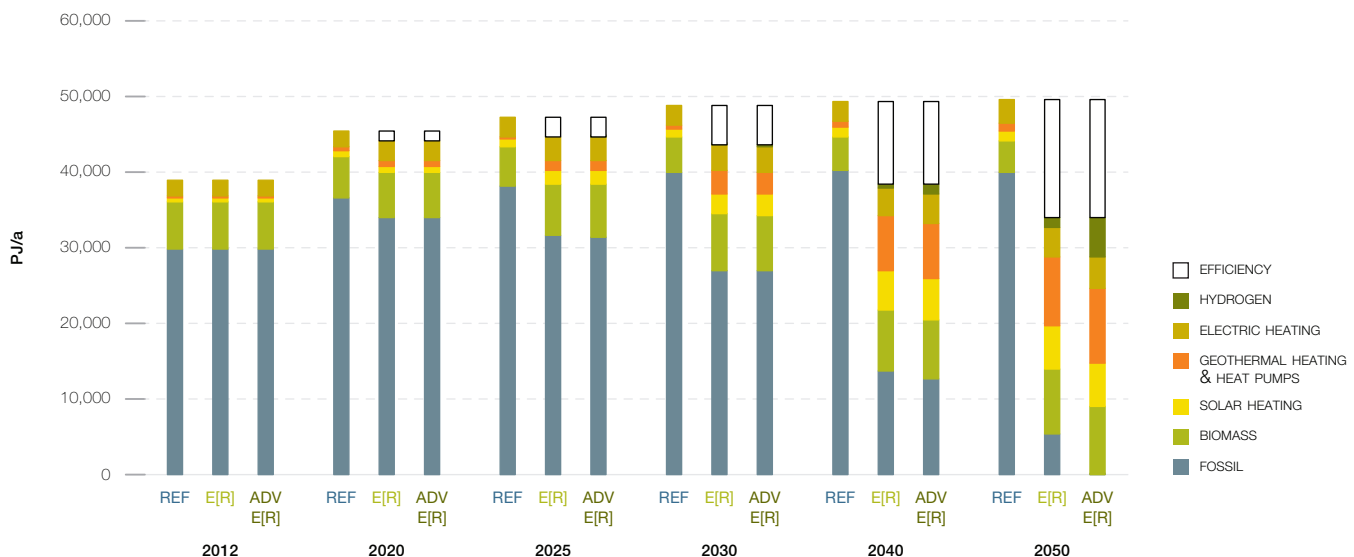
- Energy efficiency measures help to reduce the currently growing energy demand for heating by 31% in 2050 (relative to the Reference scenario), in spite of improving living standards and economic growth.
- In the industry sector solar collectors, geothermal energy (incl. heat pumps) as well as electricity and hydrogen from renewable sources are increasingly substituting for fossil fuel-fired systems.
- A shift from coal and oil to natural gas in the remaining conventional applications leads to a further reduction of CO<sub>2</sub> emissions.

Table 6.10.2 shows the development of different renewable technologies for heating in China over time. Up to 2030 biomass remains the main contributor of the growing market share. After 2030, the continuing growth of solar collectors and a growing share of geothermal and environmental heat as well as heat from renewable hydrogen will further reduce the dependence on fossil fuels. The Advanced scenario results in a complete substitution of the remaining gas consumption by hydrogen generated from renewable electricity.

**TABLE 6.10.2 | CHINA: PROJECTION OF RENEWABLE HEAT SUPPLY UNDER THE REFERENCE AND BOTH ENERGY [R]EVOLUTION SCENARIOS** IN PJ/a

		2012	2020	2030	2040	2050
BIOMASS	REF	6,221	5,131	4,832	4,539	4,382
	E[R]	6,221	6,989	7,448	7,949	8,425
	ADV	6,221	6,989	7,448	7,949	9,068
SOLAR HEATING	REF	539	928	1,036	1,114	1,207
	E[R]	539	1,713	2,716	5,427	5,859
	ADV	539	1,713	2,716	5,427	5,711
GEOHERMAL HEAT AND HEAT PUMPS	REF	256	454	527	746	1,029
	E[R]	256	1,389	2,903	7,137	8,908
	ADV	256	1,389	2,903	7,263	9,925
HYDROGEN	REF	0	0	0	0	0
	E[R]	0	0	13	520	1,469
	ADV	0	42	194	1,458	5,297
TOTAL	REF	7,016	6,513	6,395	6,399	6,618
	E[R]	7,016	10,091	13,079	21,033	24,661
	ADV	7,016	10,133	13,261	22,097	30,002

**FIGURE 6.10.8 | CHINA: PROJECTION OF HEAT SUPPLY BY ENERGY CARRIER – REFERENCE, ENERGY [R]EVOLUTION, ADVANCED ENERGY [R]EVOLUTION SCENARIOS**



### 6.10.6 FUTURE INVESTMENTS IN THE HEATING SECTOR

Also in the heating sector the Energy [R]evolution scenarios would require a major revision of current investment strategies in heating technologies. In particular, solar thermal, geothermal and heat pump technologies need an enormous increase in installations if these potentials are to be tapped for the heating sector. The use of biomass for heating purposes - often traditional biomass today - will be substantially reduced in the Energy [R]evolution scenarios and replaced by more efficient and sustainable renewable heating technologies.

Renewable heating technologies are extremely variable, from low tech biomass stoves and unglazed solar collectors to very sophisticated enhanced geothermal and solar systems. Thus, it can only be roughly estimated that the Energy [R]evolution scenario in total requires around US\$ 3,310 billion to be invested in renewable heating technologies up to 2050 (including investments for replacement after the economic lifetime of the plants) - approximately US\$ 85 billion per year. The Advanced scenario assumes an even more ambitious expansion of renewable technologies resulting in an average investment of around US\$ 86 billion per year, while the main strategy in the scenario is the substitution of the remaining natural gas amounts with hydrogen or other synthetic fuels.

**TABLE 6.10.3 | CHINA: INSTALLED CAPACITIES FOR RENEWABLE HEAT GENERATION UNDER THE SCENARIOS**

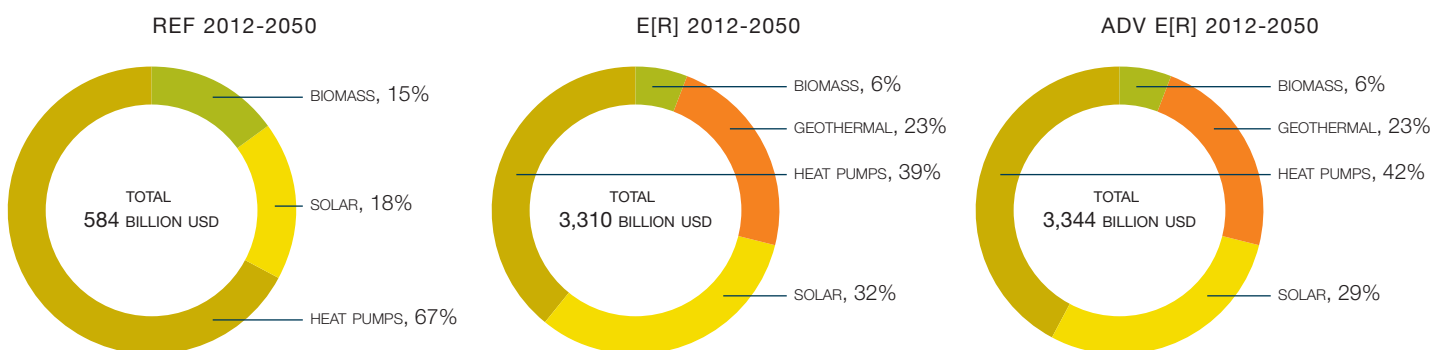
IN GW

		2012	2020	2030	2040	2050
BIOMASS	REF	2,876	2,442	2,001	1,729	1,501
	E[R]	2,876	2,556	2,243	1,695	1,460
	ADV	2,876	2,556	2,243	1,695	1,624
GEOTHERMAL	REF	0	0	0	0	0
	E[R]	0	0	78	262	366
	ADV	0	0	78	262	384
SOLAR HEATING	REF	159	243	307	333	365
	E[R]	159	279	768	1,549	1,676
	ADV	159	279	768	1,549	1,634
HEAT PUMPS	REF	46	69	96	135	187
	E[R]	46	87	274	482	564
	ADV	46	87	274	505	621
TOTAL*	REF	3,082	2,754	2,403	2,197	2,053
	E[R]	3,082	2,923	3,362	3,988	4,066
	ADV	3,082	2,923	3,362	4,011	4,263

\* Excluding direct electric heating.

6

**FIGURE 6.10.9 | CHINA: DEVELOPMENT OF INVESTMENTS FOR RENEWABLE HEAT GENERATION TECHNOLOGIES - REFERENCE, ENERGY [R]EVOLUTION, ADVANCED ENERGY [R]EVOLUTION SCENARIOS**



### 6.10.7 FUTURE EMPLOYMENT IN THE ENERGY SECTOR

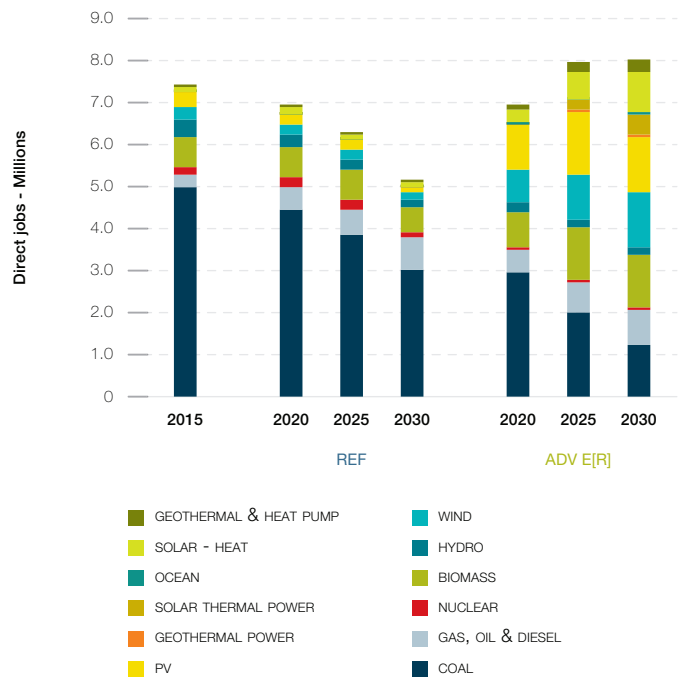
The Advanced Energy [R]evolution scenario results in more energy sector jobs in China from 2025 onwards, despite substantial reductions in fossil fuel jobs in both scenarios.

- There are 6.9 million energy sector jobs in both the Advanced Energy [R]evolution and Reference scenarios in 2020.
- In 2025, there are 8 million jobs in the Advanced Energy [R]evolution scenario, and 6.2 million in the Reference scenario.
- In 2030, there are 8 million jobs in the Advanced Energy [R]evolution scenario and 5.1 million in the Reference scenario.

Figure 6.10.10 shows the change in job numbers under both scenarios for each technology between 2015 and 2030. Jobs in the coal sector decline sharply in both scenarios, reflecting substantial increases in productivity in China's coal industry.

Strong growth in the renewable sector compensates for some of the losses in the coal industry, so while jobs in the Advanced Energy [R]evolution scenario are below 2015 levels, they are 1.7 million higher than jobs in the Reference scenario in 2025 and 2.9 million higher in 2030. Renewable energy accounts for 74% of energy jobs by 2030 in the Advanced Energy [R]evolution scenario.

**FIGURE 6.10.10 | CHINA: EMPLOYMENT IN THE ENERGY SECTOR UNDER THE REFERENCE AND ADVANCED ENERGY [R]EVOLUTION SCENARIO**



**TABLE 6.10.4 | CHINA: TOTAL EMPLOYMENT IN THE ENERGY SECTOR IN THOUSAND JOBS**

	2015	2020	REFERENCE		ADVANCED ENERGY [R]EVOLUTION		
			2025	2030	2020	2025	2030
COAL	4,985	4,462	3,832	3,029	2,950	2,016	1,238
GAS, OIL & DIESEL	316	501	632	747	549	695	852
NUCLEAR	178	253	223	170	53	46	32
RENEWABLES	1,964	1,739	1,560	1,175	3,382	5,230	5,903
<b>TOTAL JOBS</b>	<b>7,443</b>	<b>6,956</b>	<b>6,248</b>	<b>5,121</b>	<b>6,934</b>	<b>7,987</b>	<b>8,025</b>
CONSTRUCTION AND INSTALLATION	1,689	1,495	1,294	868	1,222	2,115	2,336
MANUFACTURING	868	732	659	440	1,037	1,570	1,722
OPERATIONS AND MAINTENANCE	720	998	1,075	1,039	1,059	1,373	1,653
FUEL SUPPLY (DOMESTIC)	4,167	3,730	3,219	2,773	3,615.9	2,929	2,314
COAL AND GAS EXPORT	-	-	-	-	-	-	-
<b>TOTAL JOBS</b>	<b>7,443</b>	<b>6,956</b>	<b>6,248</b>	<b>5,121</b>	<b>6,934</b>	<b>7,987</b>	<b>8,025</b>

### 6.10.8 TRANSPORT

In 2050, the car fleet in China will be significantly larger than today. Therefore a key target is the successful introduction of highly efficient vehicle concepts. In addition, it is vital to shift transport use to efficient modes like rail, light rail and buses, especially in the expanding large metropolitan areas. Along with rising prices for fossil fuels, these changes reduce the further growth in car sales projected under the Reference scenario. Due to population increase, GDP growth and higher living standards, energy demand from the transport sector is expected to strongly increase in the Reference scenario by around 158% to 25,920 PJ/a in 2050. In the basic Energy [R]evolution scenario, efficiency measures and modal shifts will save 50% (12,860 PJ/a) in 2050 compared to the Reference scenario.

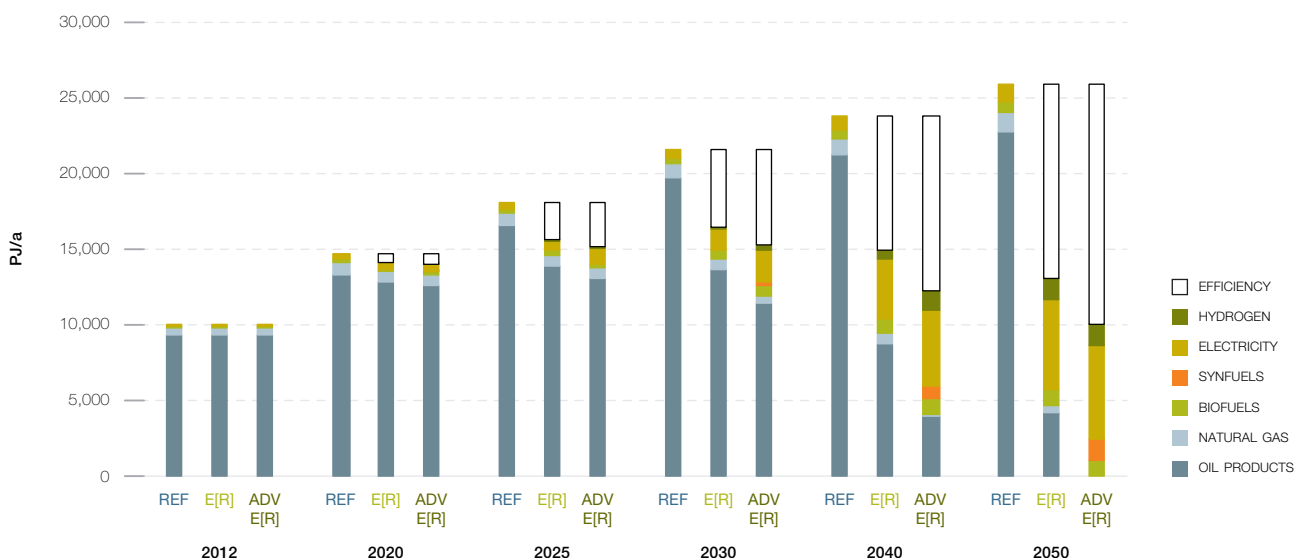
Additional modal shifts and technology switches lead to even higher energy savings in the Advanced scenario of 61% (15,940 PJ/a) in 2050 compared to the Reference scenario. Highly efficient propulsion technology with hybrid, plug-in hybrid and battery-electric power trains will bring about large efficiency gains. By 2030, electricity will provide 8% of the transport sector's total energy demand in the Energy [R]evolution, while in 2050 the share will be 46% (62% in the Advanced scenario). Hydrogen and other synthetic fuels generated using renewable electricity are complementary options to further increase the renewable share in the transport sector. In 2050, up to 1,380 PJ/a of hydrogen is used in the transport sector for the Advanced Energy [R]evolution scenario.

**TABLE 6.10.5 | CHINA: PROJECTION OF TRANSPORT ENERGY DEMAND BY MODE IN THE REFERENCE AND THE ENERGY [R]EVOLUTION SCENARIOS** IN PJ/a

		2012	2020	2030	2040	2050
RAIL	REF	582	795	835	927	1,039
	E[R]	582	742	790	850	950
	ADV	582	759	1,049	1,522	2,105
ROAD	REF	8,149	15,204	18,338	20,217	22,234
	E[R]	8,149	11,524	13,575	12,120	10,290
	ADV	8,149	11,436	12,250	9,035	6,500
DOMESTIC AVIATION	REF	513	1,082	1,184	1,260	1,279
	E[R]	513	870	1,000	880	800
	ADV	513	861	930	695	520
DOMESTIC NAVIGATION	REF	806	1,019	1,191	1,321	1,352
	E[R]	806	930	1,060	1,110	1,010
	ADV	806	930	1,030	1,000	850
TOTAL	REF	10,051	18,100	21,547	23,725	25,903
	E[R]	10,051	14,066	16,425	14,960	13,050
	ADV	10,051	13,987	15,259	12,252	9,975

6

**FIGURE 6.10.11 | CHINA: FINAL ENERGY CONSUMPTION IN TRANSPORT UNDER THE SCENARIOS**



### 6.10.10 DEVELOPMENT OF CO<sub>2</sub> EMISSIONS

Whilst China's emissions of CO<sub>2</sub> will increase by 58% between 2012 and 2050 under the Reference scenario, under the Energy [R]evolution scenario they will decrease from 8,230 million tonnes in 2012 to 1,319 million tonnes in 2050. Annual per capita emissions will drop from 5.9 tonne to 0.9 tonne. In spite of the abstinence of nuclear power production and increasing power demand, CO<sub>2</sub> emissions will decrease in the electricity sector. In the long run efficiency gains and the increased use of renewable electricity in vehicles strongly reduce emissions in the transport sector as well.

With a 40% share of CO<sub>2</sub>, the Industry sector will be the largest source of emissions in 2050 in the basic Energy [R]evolution scenario. By 2050, China's CO<sub>2</sub> emissions are around 42% below 1990 levels in the Energy [R]evolution scenario while energy consumption is fully decarbonised in the Advanced case.

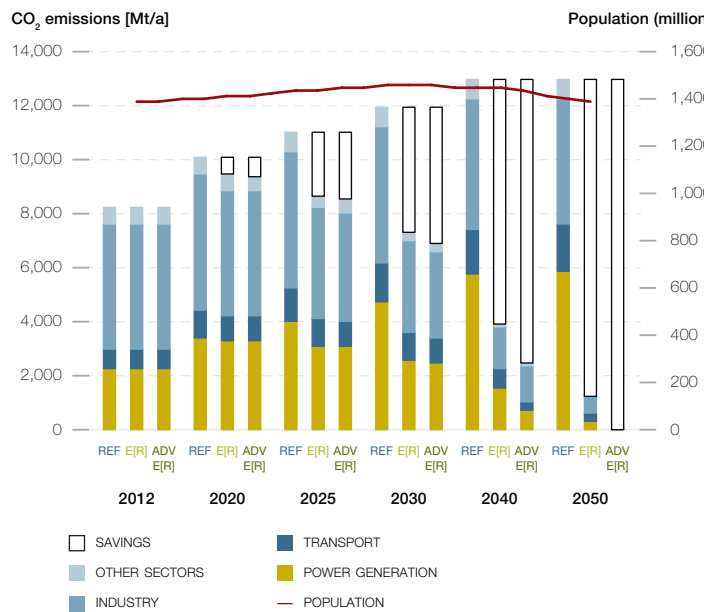
### 6.10.11 PRIMARY ENERGY CONSUMPTION

Taking into account the assumptions discussed above, the resulting primary energy consumption under the Energy [R]evolution scenarios is shown in Figure 6.10.12. Under the basic Energy [R]evolution scenario, primary energy demand will decrease by 20% from today's 114,450 PJ/a to around 91,000 PJ/a. Compared to the Reference scenario, overall primary energy demand will be reduced by 55% in 2050 under the Energy [R]evolution scenario (Reference scenario: around 203,000 PJ in 2050). The Advanced scenario results due to additional conversion losses in a primary energy consumption of around 95,300 PJ in 2050.

The Energy [R]evolution scenarios aim to phase out coal and oil as fast as technically and economically possible by

**FIGURE 6.10.13 | CHINA: DEVELOPMENT OF CO<sub>2</sub> EMISSIONS BY SECTOR UNDER THE ENERGY [R]EVOLUTION SCENARIOS**

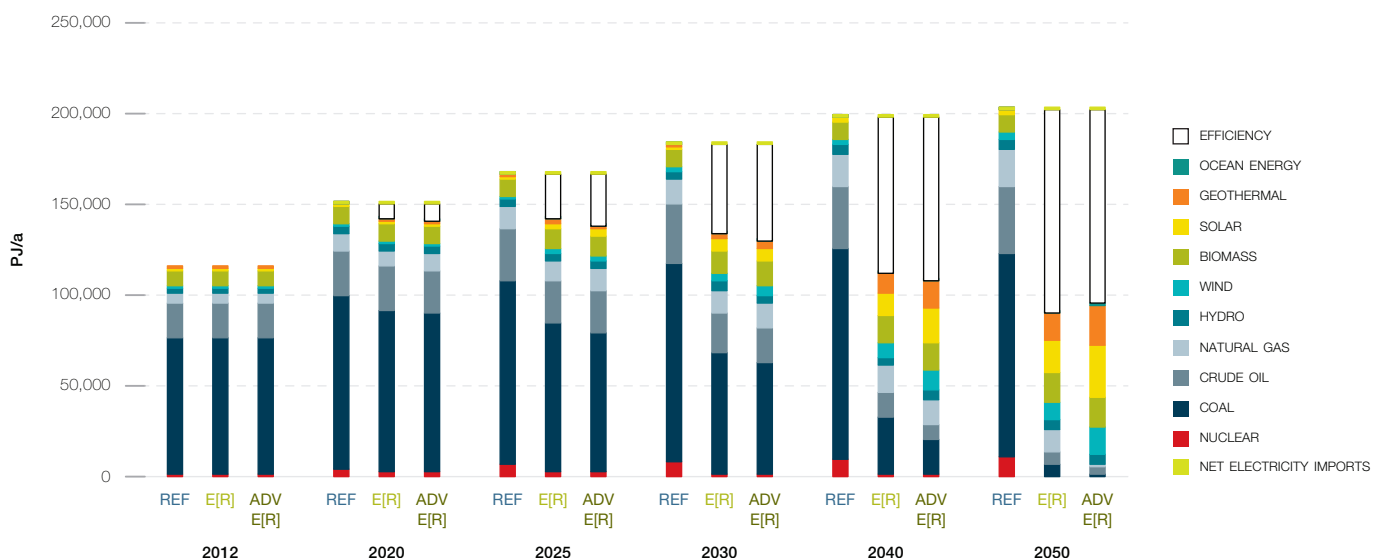
'SAVINGS' = REDUCTION COMPARED TO THE REFERENCE SCENARIO



expansion of renewable energies and a fast introduction of very efficient vehicle concepts in the transport sector to replace oil based combustion engines. This leads to an overall renewable primary energy share of 23% in 2030 and 71% in 2050 in the basic Energy [R]evolution and of more than 92% in 2050 in the Advanced case (incl. non-energy consumption). In contrast to the Reference scenario, no new nuclear power plants will be built in China in the Energy [R]evolution scenarios.

**FIGURE 6.10.12 | CHINA: PROJECTION OF TOTAL PRIMARY ENERGY DEMAND (PED) BY ENERGY CARRIER**

INCLUDING ELECTRICITY IMPORT BALANCE – REFERENCE, ENERGY [R]EVOLUTION, ADVANCED ENERGY [R]EVOLUTION SCENARIOS



**TABLE 6.10.6 | CHINA: ACCUMULATED INVESTMENT COSTS FOR ELECTRICITY GENERATION AND FUEL COST SAVINGS UNDER THE ENERGY [R]EVOLUTION SCENARIO COMPARED TO THE REFERENCE SCENARIO**

ACCUMULATED INVESTMENT COSTS DIFFERENCE REF MINUS E[R]	UNIT	2012-2020	2021-2030	2031-2040	2041-2050	2012-2050	2012 - 2050 AVERAGE PER YEAR
CONVENTIONAL (FOSSIL + NUCLEAR)	BILLION \$	109.0	725.2	637.0	539.9	2,011.1	51.6
RENEWABLES (INCL. CHP)	BILLION \$	-115.5	-1,055.6	-1,873.5	-2,155.2	-5,199.7	-133.3
TOTAL	BILLION \$	-6.5	-330.4	-1,236.5	-1,615.3	-3,188.7	-81.8
<b>ACCUMULATED FUEL COST SAVINGS</b>							
SAVINGS CUMULATIVE E[R] VERSUS REF							
FUEL OIL	BILLION \$	0.3	3.8	6.2	7.2	17.4	0.4
GAS	BILLION \$	7.1	39.7	193.2	396.6	636.6	16.3
HARD COAL	BILLION \$	20.1	1,008.2	2,784.0	3,958.5	7,770.9	199.3
LIGNITE	BILLION \$	0.0	0.0	0.0	0.0	0.0	0.0
NUCLEAR ENERGY	BILLION \$	7.5	63.8	129.5	210.7	411.4	10.5
TOTAL	BILLION \$	35.0	1,115.4	3,112.9	4,573.0	8,836.3	226.6

**TABLE 6.10.7 | CHINA: ACCUMULATED INVESTMENT COSTS FOR RENEWABLE HEAT GENERATION UNDER THE ENERGY [R]EVOLUTION SCENARIO COMPARED TO THE REFERENCE SCENARIO**

ACCUMULATED INVESTMENT COSTS DIFFERENCE REF MINUS E[R]	UNIT	2012-2020	2021-2030	2031-2040	2041-2050	2012-2050	2012 - 2050 AVERAGE PER YEAR
RENEWABLES	BILLION \$	80.2	591.9	1,201.3	857.4	2,730.8	70.0

**TABLE 6.10.8 | CHINA: ACCUMULATED INVESTMENT COSTS FOR ELECTRICITY GENERATION AND FUEL COST SAVINGS UNDER THE ADVANCED ENERGY [R]EVOLUTION SCENARIO COMPARED TO THE REFERENCE SCENARIO**

ACCUMULATED INVESTMENT COSTS DIFFERENCE REF MINUS ADVANCED E[R]	UNIT	2012-2020	2021-2030	2031-2040	2041-2050	2012-2050	2012 - 2050 AVERAGE PER YEAR
CONVENTIONAL (FOSSIL + NUCLEAR)	BILLION \$	109.3	734.4	628.2	401.3	1,873.3	48.0
RENEWABLES (INCL. CHP)	BILLION \$	-160.1	-1,749.9	-3,605.6	-3,510.4	-9,025.9	-231.4
TOTAL	BILLION \$	-50.8	-1,015.4	-2,977.3	-3,109.1	-7,152.7	-183.4
<b>ACCUMULATED FUEL COST SAVINGS</b>							
SAVINGS CUMULATIVE ADVANCED E[R] VERSUS REF							
FUEL OIL	BILLION \$	0.3	3.8	6.2	7.2	17.4	0.4
GAS	BILLION \$	7.1	43.6	228.4	671.5	950.7	24.4
HARD COAL	BILLION \$	20.4	1,024.3	2,963.7	4,219.5	8,227.9	211.0
LIGNITE	BILLION \$	0.0	0.0	0.0	0.0	0.0	0.0
NUCLEAR ENERGY	BILLION \$	7.5	63.8	129.5	210.7	411.4	10.5
TOTAL	BILLION \$	35.2	1,135.5	3,327.8	5,108.9	9,607.4	246.3

**TABLE 6.10.9 | CHINA: ACCUMULATED INVESTMENT COSTS FOR RENEWABLE HEAT GENERATION UNDER THE ADVANCED ENERGY [R]EVOLUTION SCENARIO COMPARED TO THE REFERENCE SCENARIO**

ACCUMULATED INVESTMENT COSTS DIFFERENCE REF MINUS ADVANCED E[R]	UNIT	2012-2020	2021-2030	2031-2040	2041-2050	2012-2050	2012 - 2050 AVERAGE PER YEAR
RENEWABLES	BILLION \$	80.2	591.9	1,238.8	849.6	2,760.5	70.8

## 6.11 OECD ASIA OCEANIA

### 6.11.1 FINAL ENERGY DEMAND BY SECTOR

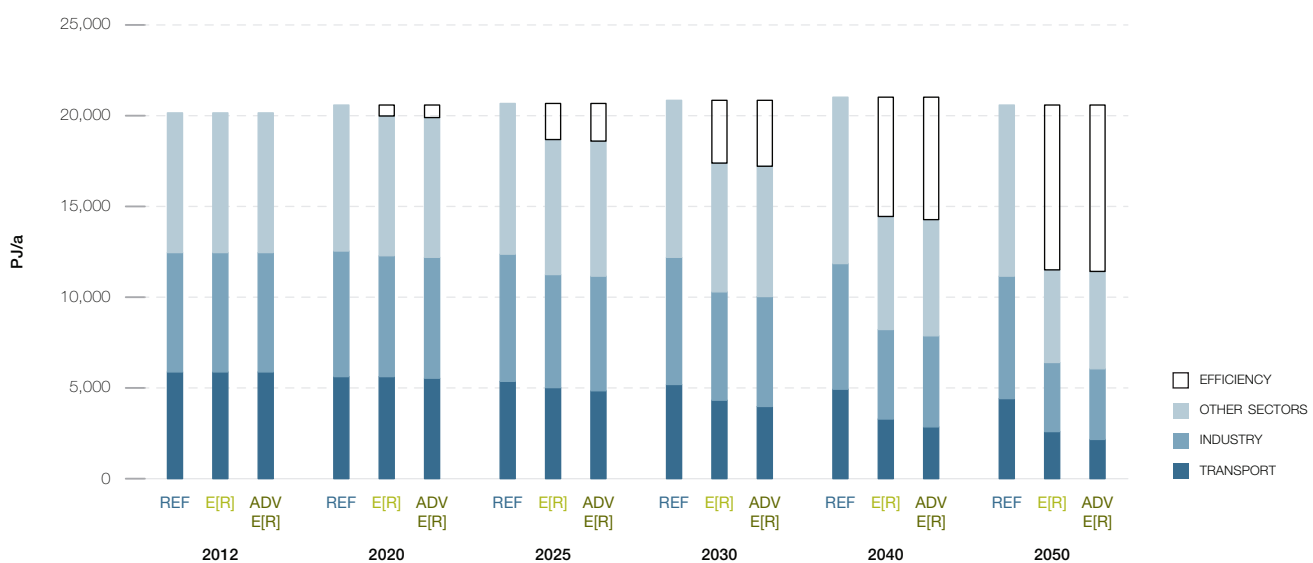
Combining the projections on population development, GDP growth and energy intensity results in future development pathways for OECD Asia Oceania's final energy demand. These are shown in Figure 6.11.1 for the Reference and Energy [R]evolution scenarios. Under the Reference scenario, total final energy demand increases by 2% from the current 20,100 PJ/a to 20,600 PJ/a in 2050. In the basic Energy [R]evolution scenario, final energy demand decreases by 43% compared to current consumption and is expected to reach 11,500 PJ/a by 2050. The Advanced scenario results in some additional reductions due to a higher share of electric cars.

Under both Energy [R]evolution scenarios, due to economic growth, increasing living standards and electrification of the transport sector, overall electricity demand is expected to increase despite efficiency gains in all sectors (see Figure 6.11.2). Total electricity demand will rise from about 1,650 TWh/a to 1,720 TWh/a by 2050 in the basic Energy [R]evolution scenario. Compared to the Reference scenario, efficiency measures in the industry, residential and service sectors avoid the generation of about 940 TWh/a.

This reduction can be achieved in particular by introducing highly efficient electronic devices using the best available technology in all demand sectors. The transformation to a carbon free energy system in the Advanced scenario will further increase the electricity demand in 2050 up to 1,900 TWh/a. Electricity will become the major renewable 'primary' energy, not only for direct use for various purposes but also for the generation of synthetic fuels for fossil fuels substitution. Around 330 TWh are used in 2050 for electric vehicles and rail transport in 2050 in the Advanced scenario, around 210 TWh for hydrogen and 220 TWh for synthetic liquid fuel generation for the transport sector (excluding bunkers).

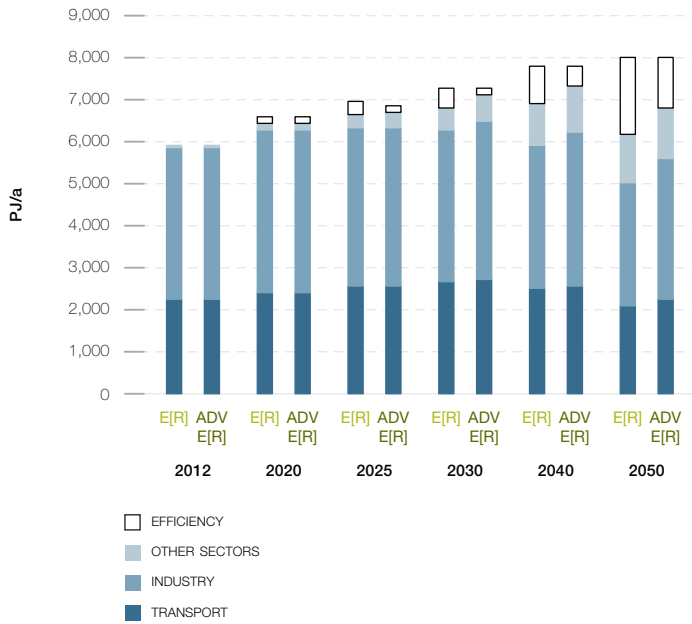
Efficiency gains in the heating sector are large as well. Under the Energy [R]evolution scenarios, consumption equivalent to about 3,000 PJ/a is avoided through efficiency gains by 2050 compared to the Reference scenario. As a result of energy-related renovation of the existing stock of residential buildings, the introduction of low energy standards and 'passive climatisation' for new buildings, as well as highly efficient air conditioning systems, enjoyment of the same comfort and energy services will be accompanied by much lower future energy demand.

**FIGURE 6.11.1 | OECD ASIA OCEANIA: PROJECTION OF TOTAL FINAL ENERGY DEMAND BY SECTOR – REFERENCE, ENERGY [R]EVOLUTION, ADVANCED ENERGY [R]EVOLUTION SCENARIOS** WITHOUT NON-ENERGY USE AND HEAT FROM CHP AUTOPRODUCERS

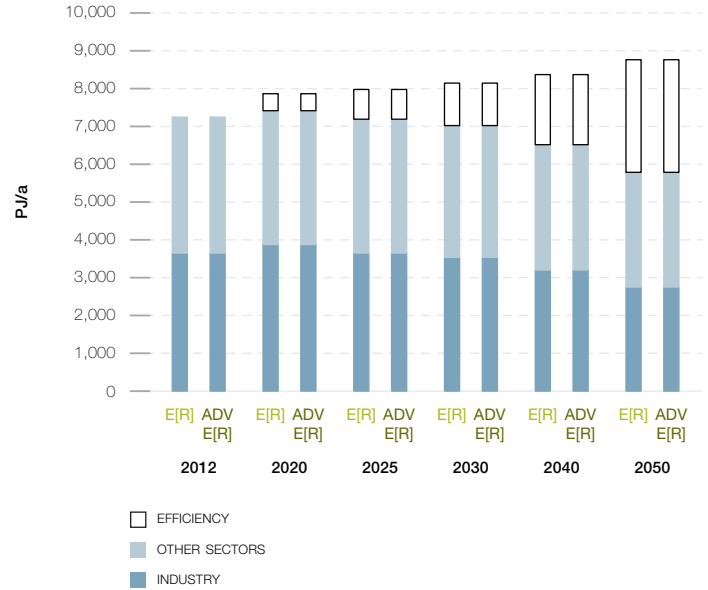




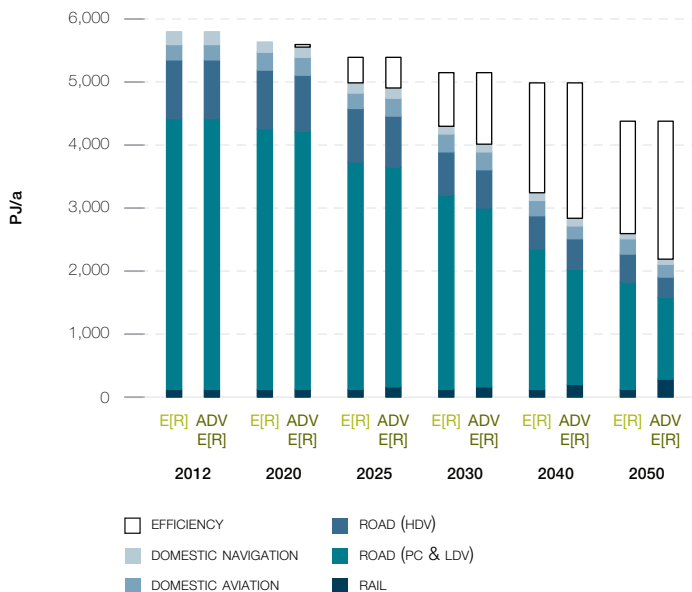
**FIGURE 6.11.2 | OECD ASIA OCEANIA: DEVELOPMENT OF ELECTRICITY DEMAND BY SECTOR IN THE ENERGY [R]EVOLUTION SCENARIOS**



**FIGURE 6.11.4 | OECD ASIA OCEANIA: DEVELOPMENT OF FINAL ENERGY DEMAND FOR HEAT BY SECTOR IN THE ENERGY [R]EVOLUTION SCENARIOS**



**FIGURE 6.11.3 | OECD ASIA OCEANIA: DEVELOPMENT OF THE FINAL ENERGY DEMAND FOR TRANSPORT BY SECTOR IN THE ENERGY [R]EVOLUTION SCENARIOS**



### 6.11.2 ELECTRICITY GENERATION

The development of the electricity supply sector is characterised by a dynamically growing renewable energy market and an increasing share of renewable electricity. This trend will more than compensate for the phasing out of nuclear power production in the Energy [R]evolution scenarios, continuously reducing the number of fossil fuel-fired power plants as well. By 2050, 95% of the electricity produced in OECD Asia Oceania will come from renewable energy sources in the basic Energy [R]evolution scenario. ‘New’ renewables – mainly wind, PV, ocean and geothermal energy – will contribute 76% to the total electricity generation. Already by 2020 the share of renewable electricity production will be 28% and 58% by 2030. The installed capacity of renewables will reach about 550 GW in 2030 and 870 GW by 2050.

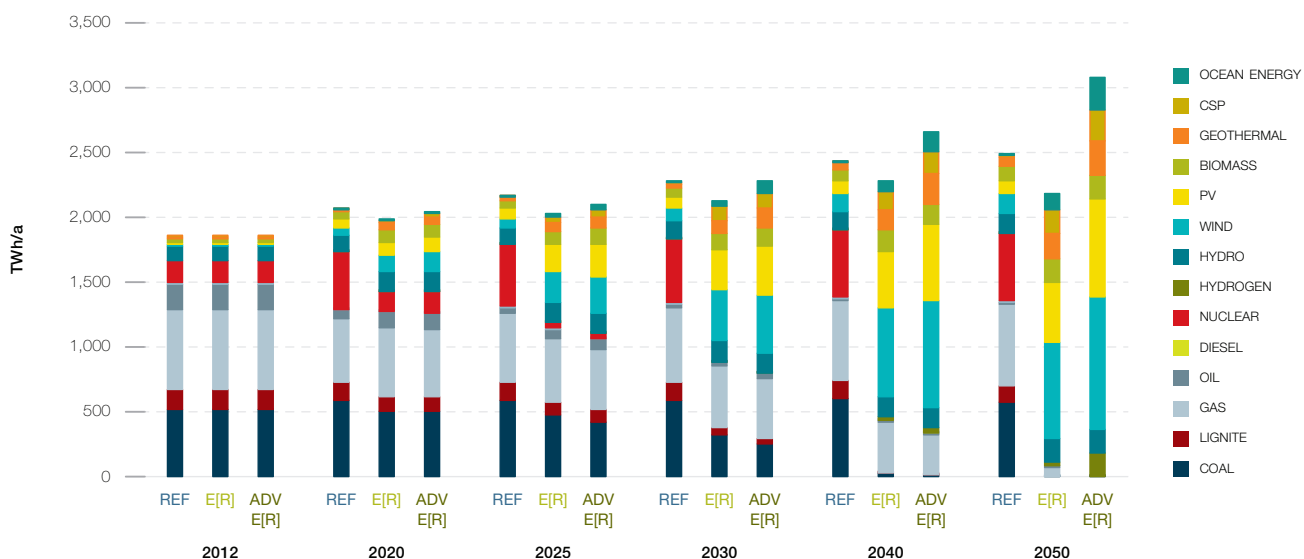
A 100% electricity supply from renewable energy resources in the Advanced scenario leads to around 1,250 GW installed generation capacity in 2050.

Table 6.11.1 shows the comparative evolution of the different renewable technologies in OECD Asia Oceania over time. Until 2020 hydro will remain the main renewable power source. After 2020, the continuing growth of wind and PV will be complemented by electricity from solar thermal, geothermal and ocean energy. The Energy [R]evolution scenarios will lead to a high share of fluctuating power generation sources (PV, wind and ocean) of already 35% to 40% by 2030 and 61% to 66% by 2050. Therefore, smart grids, demand side management (DSM), energy storage capacities and other options need to be expanded in order to increase the flexibility of the power system for grid integration, load balancing and a secure supply of electricity.

**TABLE 6.11.1 | OECD ASIA OCEANIA: PROJECTION OF RENEWABLE ELECTRICITY GENERATION CAPACITY UNDER THE REFERENCE AND THE ENERGY [R]EVOLUTION SCENARIOS IN GW**

		2012	2020	2030	2040	2050
HYDRO	REF	69	71	74	76	76
	E[R]	69	80	83	83	92
	ADV	69	80	83	83	92
BIOMASS	REF	6	10	12	15	18
	E[R]	6	14	20	29	58
	ADV	6	14	23	29	39
WIND	REF	6	16	31	44	51
	E[R]	6	45	125	208	223
	ADV	6	55	143	248	310
GEOTHERMAL	REF	1	2	5	7	10
	E[R]	1	8	16	24	30
	ADV	1	8	23	39	49
PV	REF	10	59	71	79	89
	E[R]	10	84	264	370	394
	ADV	10	101	315	496	637
CSP	REF	0	0	1	2	2
	E[R]	0	4	25	28	35
	ADV	0	7	30	34	50
OCEAN	REF	0	1	1	2	3
	E[R]	0	3	14	26	40
	ADV	0	3	28	48	76
TOTAL	REF	93	159	194	225	250
	E[R]	93	239	548	767	872
	ADV	93	268	644	976	1,252

**FIGURE 6.11.5 | OECD ASIA OCEANIA: DEVELOPMENT OF ELECTRICITY GENERATION STRUCTURE – REFERENCE, ENERGY [R]EVOLUTION, ADVANCED ENERGY [R]EVOLUTION SCENARIOS**



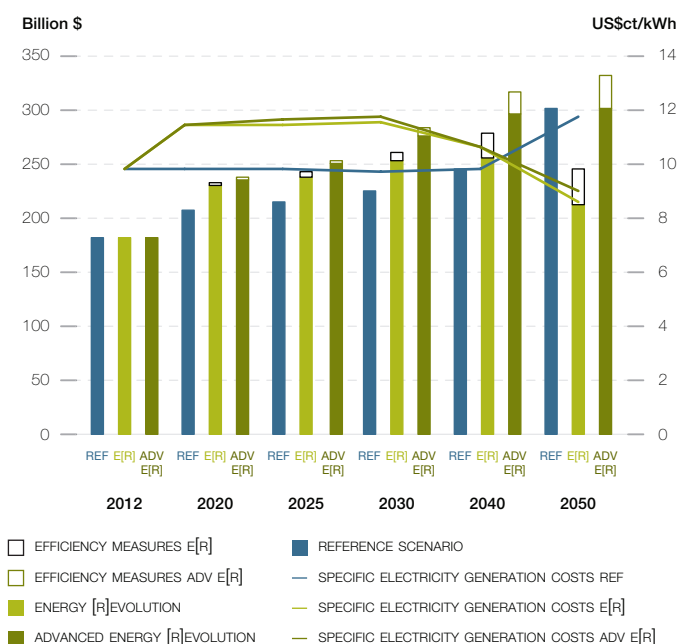
### 6.11.3 FUTURE COSTS OF ELECTRICITY GENERATION

Figure 6.11.6 shows that the introduction of renewable technologies under both Energy [R]evolution scenarios increases the future costs of electricity generation compared to the Reference scenario until 2030. This difference in full cost of generation will be less than 1.8 US\$/kWh in the basic Energy [R]evolution and about 2.1 US\$/kWh in the Advanced scenario, without taking into account integration costs for storage or other load-balancing measures. Because of increasing prices for conventional fuels and the lower CO<sub>2</sub> intensity of electricity generation, electricity generation costs will become economically favourable after 2040 under the Energy [R]evolution scenarios. By 2050, the cost will be 3.1/2.7 US\$/kWh, respectively, below those in the Reference case.

Under the Reference scenario, on the other hand, growth in demand and increasing fossil fuel prices result in total electricity supply costs rising from today's US\$ 183 billion per year to more than US\$ 302 billion in 2050, compared to US\$ 212 billion in the basic and US\$ 301 billion in the Advanced Energy [R]evolution scenario. Figure 6.11.6 shows that both Energy [R]evolution scenarios will help to comply with OECD Asia Oceania's CO<sub>2</sub> reduction targets, and eventually will also help to stabilise energy costs.

Increasing energy efficiency and shifting energy supply to renewables lead to long term investment costs for electricity supply that are more than 30% lower in the basic Energy [R]evolution scenario than in the Reference scenario. The Advanced scenario with 100% renewable power and an increase in power generation of 24% results in supply costs similar to the Reference case.

**FIGURE 6.11.6 | OECD ASIA OCEANIA: DEVELOPMENT OF TOTAL ELECTRICITY SUPPLY COSTS & OF SPECIFIC ELECTRICITY GENERATION COSTS IN THE SCENARIOS**



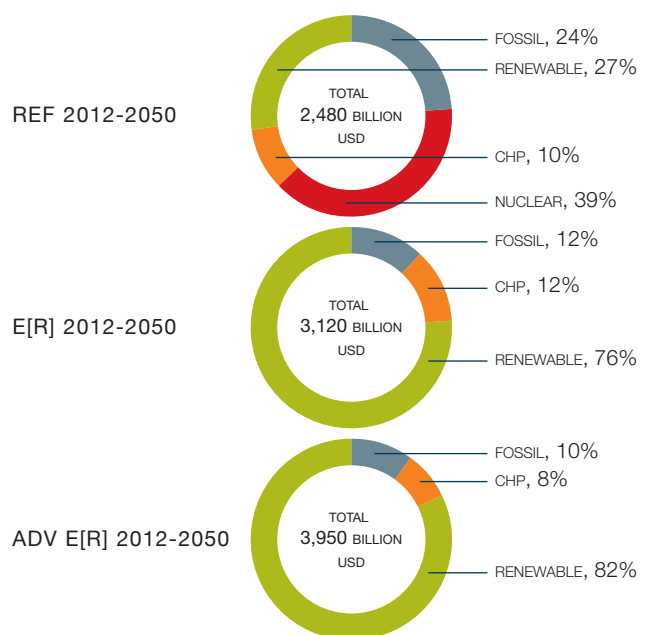
### 6.11.4 FUTURE INVESTMENTS IN THE POWER SECTOR

Around US\$ 3,120 billion is required in investment for the Energy [R]evolution scenario to become reality (including investments for replacement after the economic lifetime of the plants) - approximately US\$ 80 billion per year, US\$ 650 billion more than in the Reference scenario (US\$ 2,480 billion). Investments for the Advanced scenario sum up to US\$ 3,950 billion until 2050, on average US\$ 101 billion per year. Under the Reference scenario, the levels of investment in conventional power plants add up to almost 62% while approximately 38% would be invested in renewable energies and cogeneration until 2050.

Under the Energy [R]evolution scenarios, however, OECD Asia Oceania would shift almost 88%/90% of the entire investment towards renewables and cogeneration, respectively. By 2030, the fossil fuel share of power sector investment would be focused mainly on gas power plants.

Because renewable energy has no fuel costs, the fuel cost savings in the basic Energy [R]evolution scenario reach a total of US\$ 2,170 billion up to 2050, US\$ 56 billion per year. The total fuel cost savings therefore would cover 330% of the total additional investments compared to the Reference scenario. Fuel cost savings in the Advanced scenario are even higher and add up to US\$ 2,400 billion, or US\$ 62 billion per year. Renewable energy sources would then go on to produce electricity without any further fuel costs beyond 2050, while costs for coal and gas will continue to be a burden on national economies.

**FIGURE 6.11.7 | OECD ASIA OCEANIA: INVESTMENT SHARES - REFERENCE VERSUS ENERGY [R]EVOLUTION SCENARIOS**



### 6.11.5 ENERGY SUPPLY FOR HEATING

Today, renewables meet around 5% of OECD Asia Oceania's energy demand for heating, the main contribution coming from the use of biomass. Dedicated support instruments are required to ensure a dynamic development in particular for renewable technologies for buildings and renewable process heat production. In the basic Energy [R]evolution scenario, renewables already provide 35% of OECD Asia Oceania's total heat demand in 2030 and 93% in 2050.

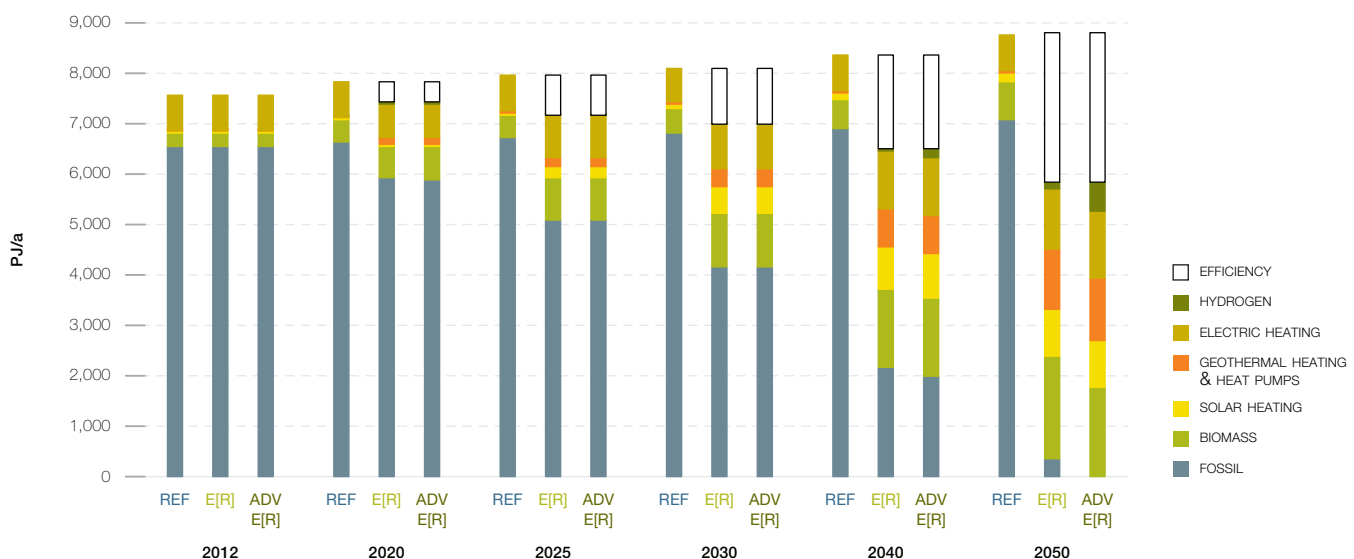
- Energy efficiency measures help to reduce the currently growing energy demand for heating by 34% in 2050 (relative to the Reference scenario), in spite of improving living standards and economic growth.
- In the industry sector solar collectors, geothermal energy (incl. heat pumps) as well as electricity and hydrogen from renewable sources are increasingly substituting for fossil fuel-fired systems.
- A shift from coal and oil to natural gas in the remaining conventional applications leads to a further reduction of CO<sub>2</sub> emissions.

Table 6.11.8 shows the development of different renewable technologies for heating in OECD Asia Oceania over time. Biomass remains the main contributor, with increasing investments in highly efficient modern biomass technology. After 2030, a massive growth of solar collectors and a growing share of geothermal and environmental heat as well as heat from renewable hydrogen can further reduce the dependence on fossil fuels. The Advanced scenario results in a complete substitution of the remaining gas consumption by hydrogen generated from renewable electricity.

**TABLE 6.11.2 | OECD ASIA OCEANIA: PROJECTION OF RENEWABLE HEAT SUPPLY UNDER THE REFERENCE AND BOTH ENERGY [R]EVOLUTION SCENARIOS** IN PJ/a

		2012	2020	2030	2040	2050
BIOMASS	REF	268	460	501	589	733
	E[R]	268	842	1,059	1,543	2,012
	ADV	268	842	1,059	1,548	1,758
SOLAR HEATING	REF	27	64	81	131	199
	E[R]	27	243	495	852	911
	ADV	27	243	495	852	921
GEOTHERMAL HEAT AND HEAT PUMPS	REF	30	33	34	36	38
	E[R]	30	193	360	780	1,233
	ADV	30	193	360	780	1,238
HYDROGEN	REF	0	0	0	0	0
	E[R]	0	4	11	27	131
	ADV	0	4	11	169	533
TOTAL	REF	326	556	615	757	970
	E[R]	326	1,282	1,925	3,202	4,286
	ADV	326	1,282	1,925	3,349	4,450

**FIGURE 6.11.8 | OECD ASIA OCEANIA: PROJECTION OF HEAT SUPPLY BY ENERGY CARRIER – REFERENCE, ENERGY [R]EVOLUTION, ADVANCED ENERGY [R]EVOLUTION SCENARIOS**



### 6.11.6 FUTURE INVESTMENTS IN THE HEATING SECTOR

Also in the heating sector the Energy [R]evolution scenarios would require a major revision of current investment strategies in heating technologies. In particular, solar thermal, geothermal and heat pump technologies need an enormous increase in installations if these potentials are to be tapped for the heating sector. The use of biomass for heating purposes will shift from often traditional biomass today to modern, efficient and environmentally friendly heating technologies in the Energy [R]evolution scenarios.

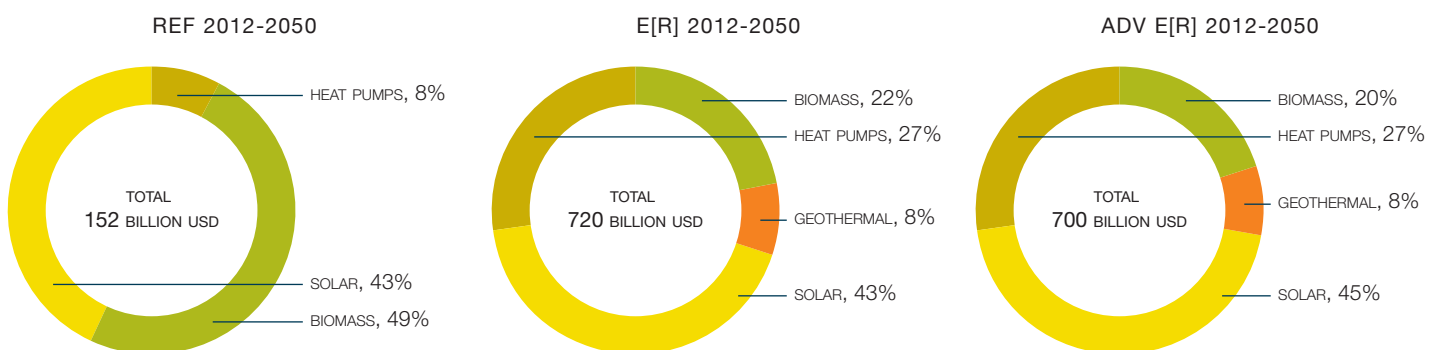
Renewable heating technologies are extremely variable, from low tech biomass stoves and unglazed solar collectors to very sophisticated enhanced geothermal and solar systems. Thus, it can only be roughly estimated that the Energy [R]evolution scenario in total requires around US\$ 720 billion to be invested in renewable heating technologies up to 2050 (including investments for replacement after the economic lifetime of the plants) - approximately US\$ 18 billion per year. The Advanced scenario assumes an equally ambitious expansion of renewable technologies assuming a slightly higher share of direct electric heating, while the main strategy in the scenario is the substitution of the remaining natural gas amounts with electricity, hydrogen or other synthetic fuels.

**TABLE 6.11.3 | OECD ASIA OCEANIA: INSTALLED CAPACITIES FOR RENEWABLE HEAT GENERATION UNDER THE SCENARIOS** IN GW

		2012	2020	2030	2040	2050
BIOMASS	REF	40	59	69	77	87
	E[R]	40	87	130	164	164
	ADV	40	86	130	164	122
GEOTHERMAL	REF	0	0	0	0	0
	E[R]	0	3	8	14	24
	ADV	0	3	8	14	25
SOLAR HEATING	REF	9	14	25	41	62
	E[R]	9	15	151	258	277
	ADV	9	15	151	258	280
HEAT PUMPS	REF	5	5	5	6	6
	E[R]	5	7	28	69	94
	ADV	5	7	28	69	95
TOTAL*	REF	53	78	100	124	155
	E[R]	53	111	317	506	560
	ADV	53	110	317	506	522

\* Excluding direct electric heating.

**FIGURE 6.11.9 | OECD ASIA OCEANIA: DEVELOPMENT OF INVESTMENTS FOR RENEWABLE HEAT GENERATION TECHNOLOGIES – REFERENCE, ENERGY [R]EVOLUTION, ADVANCED ENERGY [R]EVOLUTION SCENARIOS**



### 6.11.7 FUTURE EMPLOYMENT IN THE ENERGY SECTOR

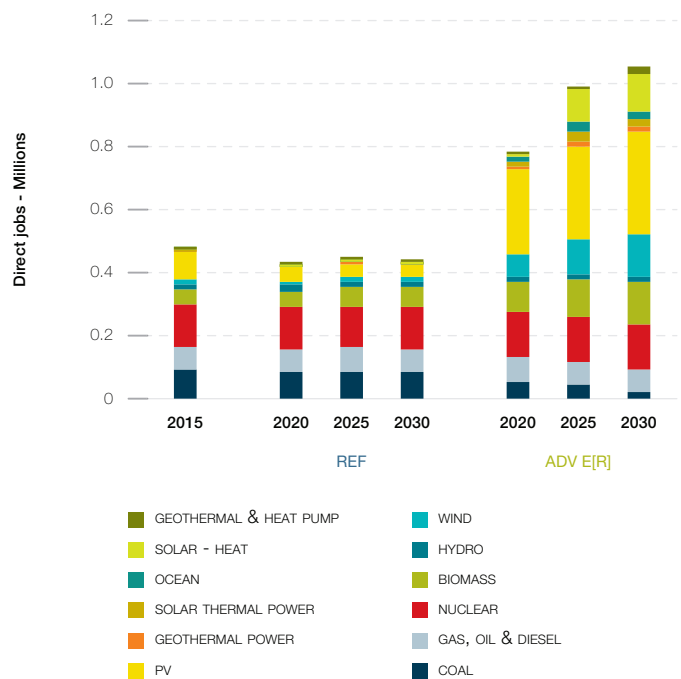
The Advanced Energy [R]evolution scenario results in more energy sector jobs in OECD Asia Oceania at every stage of the projection.

- There are 0.8 million energy sector jobs in the Advanced Energy [R]evolution in 2020, and 0.4 million in the Reference scenario.
- In 2025, there are 1 million jobs in the Advanced Energy [R]evolution scenario, and 0.4 million in the Reference scenario.
- In 2030, there are 1.1 million jobs in the Advanced Energy [R]evolution scenario and 0.4 million in the Reference scenario.

Figure 6.11.4 shows the change in job numbers under both scenarios for each technology between 2015 and 2030. Jobs in the Reference scenario drop to 10% below 2015 levels by 2020 and then remain quite stable to 2030.

Strong growth in renewable energy leads to an increase of 63% in total energy sector jobs in the Advanced Energy [R]evolution scenario by 2020. By 2030, energy jobs are more than double 2015 levels. Renewable energy accounts for 78% at 2030, with PV having the greatest share (32%), followed by biomass, wind, and solar heating.

**FIGURE 6.11.10 | OECD ASIA OCEANIA: EMPLOYMENT IN THE ENERGY SECTOR UNDER THE REFERENCE AND ADVANCED ENERGY [R]EVOLUTION**



**TABLE 6.11.4 | OECD ASIA OCEANIA: TOTAL EMPLOYMENT IN THE ENERGY SECTOR IN THOUSAND JOBS**

	2015	2020	REFERENCE		ADVANCED ENERGY [R]EVOLUTION		
			2025	2030	2020	2025	2030
COAL	90	81	88	88	52	41	24
GAS, OIL & DIESEL	78	72	73	70	77	72	72
NUCLEAR	134	135	133	133	145	144	140
RENEWABLES	177	140	147	147	509	735	820
<b>TOTAL JOBS</b>	<b>478</b>	<b>428</b>	<b>442</b>	<b>438</b>	<b>782</b>	<b>992</b>	<b>1,056</b>
CONSTRUCTION AND INSTALLATION	190	128	127	115	371	467	477
MANUFACTURING	37	17	17	12	99	141	149
OPERATIONS AND MAINTENANCE	135	158	160	162	176	233	276
FUEL SUPPLY (DOMESTIC)	112	114	118	123	131.6	149	154
COAL AND GAS EXPORT	5	11	19	27	4	2.3	0.8
<b>TOTAL JOBS</b>	<b>478</b>	<b>428</b>	<b>442</b>	<b>438</b>	<b>782</b>	<b>992</b>	<b>1,056</b>

### 6.11.8 TRANSPORT

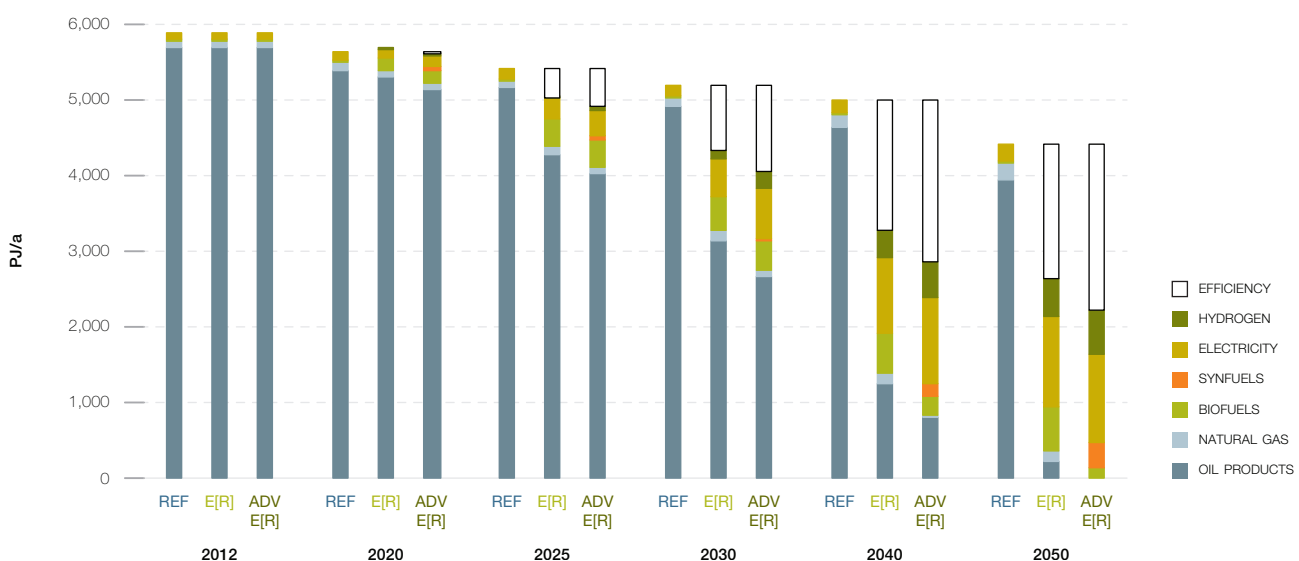
A key target in OECD Asia Oceania is to introduce incentives for people to drive smaller cars and buy new, more efficient vehicle concepts. In addition, it is vital to shift transport use to efficient modes like rail, light rail and buses, especially in the expanding large metropolitan areas. Along with rising prices for fossil fuels, these changes reduce the further growth in car sales projected under the Reference scenario. Despite population increase, GDP growth and higher living standards, energy demand from the transport sector is expected to decrease in the Reference scenario by around 25% to 4,400 PJ/a in 2050. In the basic Energy [R]evolution scenario, efficiency measures and modal shifts will save 40% (1,780 PJ/a) in 2050 compared to the Reference scenario.

Additional modal shifts and technology switches lead to even higher energy savings in the Advanced scenario of 50% (2,180 PJ/a) in 2050 compared to the Reference scenario. Highly efficient propulsion technology with hybrid, plug-in hybrid and battery-electric power trains will bring about large efficiency gains. By 2030, electricity will provide 12% of the transport sector's total energy demand in the Energy [R]evolution, while in 2050 the share will be 45% (53% in the Advanced scenario). Hydrogen and other synthetic fuels generated using renewable electricity are complementary options to further increase the renewable share in the transport sector. In 2050, up to 580 PJ/a of hydrogen is used in the transport sector for the Advanced Energy [R]evolution scenario.

**TABLE 6.11.5 | OECD ASIA OCEANIA: PROJECTION OF TRANSPORT ENERGY DEMAND BY MODE IN THE REFERENCE AND THE ENERGY [R]EVOLUTION SCENARIOS IN PJ/a**

		2012	2020	2030	2040	2050
RAIL	REF	149	152	152	153	154
	E[R]	149	144	132	131	138
	ADV	149	157	191	231	285
ROAD	REF	5,203	4,757	4,538	4,332	3,755
	E[R]	5,203	5,037	3,784	2,771	2,150
	ADV	5,203	4,958	3,449	2,282	1,650
DOMESTIC AVIATION	REF	254	317	325	342	338
	E[R]	254	298	258	239	221
	ADV	254	295	245	203	172
DOMESTIC NAVIGATION	REF	203	165	160	150	140
	E[R]	203	173	151	130	110
	ADV	203	173	151	130	110
TOTAL	REF	5,808	5,390	5,175	4,977	4,387
	E[R]	5,808	5,652	4,325	3,271	2,619
	ADV	5,808	5,584	4,036	2,845	2,217

**FIGURE 6.11.11 | OECD ASIA OCEANIA: FINAL ENERGY CONSUMPTION IN TRANSPORT UNDER THE SCENARIOS**



### 6.11.10 DEVELOPMENT OF CO<sub>2</sub> EMISSIONS

Whilst OECD Asia Oceania's emissions of CO<sub>2</sub> will decrease by 22% between 2012 and 2050 under the Reference scenario, under the Energy [R]evolution scenario they will decrease from 2,210 million tonnes in 2012 to 85 million tonnes in 2050. Annual per capita emissions will drop from 10.9 tonne to 0.4 tonne. In spite of the abstinence of nuclear power production and increasing power demand, CO<sub>2</sub> emissions will decrease in the electricity sector. In the long run efficiency gains and the increased use of renewable electricity in vehicles strongly reduce emissions in the transport sector as well.

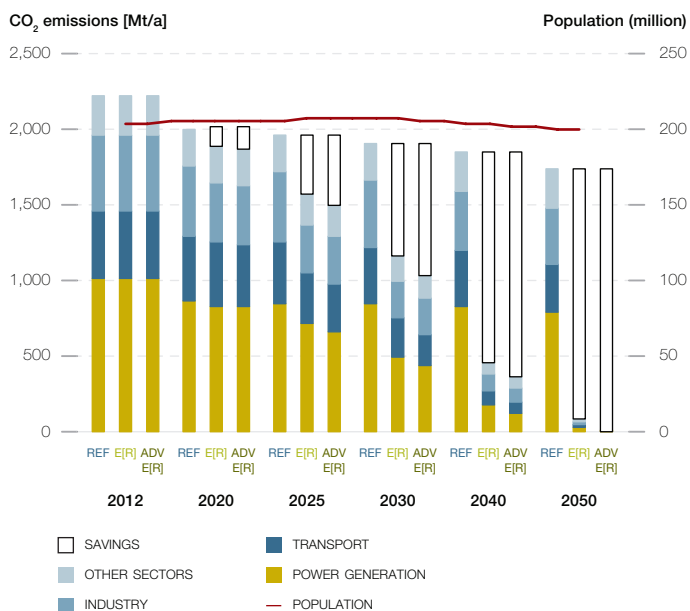
With a 29% share of CO<sub>2</sub>, the Industry sector will be the largest source of emissions in 2050 in the basic Energy [R]evolution scenario. By 2050, OECD Asia Oceania's CO<sub>2</sub> emissions are around 95% below 1990 levels in the Energy [R]evolution scenario while energy consumption is fully decarbonised in the Advanced case.

### 6.11.11 PRIMARY ENERGY CONSUMPTION

Taking into account the assumptions discussed above, the resulting primary energy consumption under the Energy [R]evolution scenarios is shown in Figure 6.11.12. Under the basic Energy [R]evolution scenario, primary energy demand will decrease by 47% from today's 35,800 PJ/a to around 19,000 PJ/a. Compared to the Reference scenario, overall primary energy demand will be reduced by 48% in 2050 under the Energy [R]evolution scenario (Reference scenario: around 36,000 PJ in 2050). The Advanced scenario results due to additional conversion losses in a primary energy consumption of around 20,900 PJ in 2050.

The Energy [R]evolution scenarios aim to phase out coal and oil as fast as technically and economically possible by

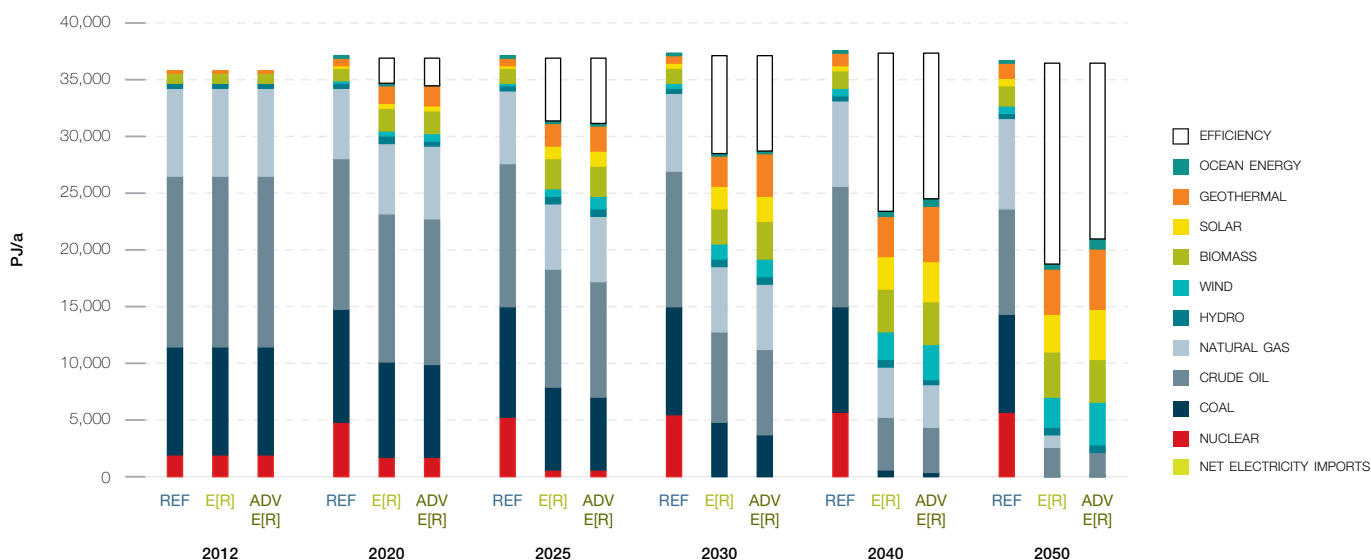
**FIGURE 6.11.13 | OECD ASIA OCEANIA: DEVELOPMENT OF CO<sub>2</sub> EMISSIONS BY SECTOR UNDER THE ENERGY [R]EVOLUTION SCENARIOS** 'SAVINGS' = REDUCTION COMPARED TO THE REFERENCE SCENARIO



expansion of renewable energies and a fast introduction of very efficient vehicle concepts in the transport sector to replace oil based combustion engines. This leads to an overall renewable primary energy share of 35% in 2030 and 81% in 2050 in the basic Energy [R]evolution and of more than 89% in 2050 in the Advanced case (incl. non-energy consumption). In contrast to the Reference scenario, no new nuclear power plants will be built in OECD Asia Oceania in the Energy [R]evolution scenarios.

**FIGURE 6.11.12 | OECD ASIA OCEANIA: PROJECTION OF TOTAL PRIMARY ENERGY DEMAND (PED) BY ENERGY CARRIER**

INCLUDING ELECTRICITY IMPORT BALANCE – REFERENCE, ENERGY [R]EVOLUTION, ADVANCED ENERGY [R]EVOLUTION SCENARIOS





**TABLE 6.11.6 | OECD ASIA OCEANIA: ACCUMULATED INVESTMENT COSTS FOR ELECTRICITY GENERATION AND FUEL COST SAVINGS UNDER THE ENERGY [R]EVOLUTION SCENARIO COMPARED TO THE REFERENCE SCENARIO**

ACCUMULATED INVESTMENT COSTS DIFFERENCE REF MINUS E[R]	UNIT	2012-2020	2021-2030	2031-2040	2041-2050	2012-2050	2012 - 2050 AVERAGE PER YEAR
CONVENTIONAL (FOSSIL + NUCLEAR)	BILLION \$	183.8	309.8	338.1	311.6	1,143.3	29.3
RENEWABLES (INCL. CHP)	BILLION \$	-220.5	-589.4	-408.5	-588.7	-1,807.1	-46.3
TOTAL	BILLION \$	-36.7	-279.5	-70.4	-277.1	-663.8	-17.0
<b>ACCUMULATED FUEL COST SAVINGS</b>							
SAVINGS CUMULATIVE E[R] VERSUS REF							
FUEL OIL	BILLION \$	-31.2	-40.5	22.9	39.5	-9.4	-0.2
GAS	BILLION \$	-12.3	119.3	346.8	731.6	1,185.4	30.4
HARD COAL	BILLION \$	24.3	111.2	225.3	273.9	634.7	16.3
LIGNITE	BILLION \$	1.6	11.1	23.6	28.7	65.0	1.7
NUCLEAR ENERGY	BILLION \$	11.4	65.3	96.7	119.2	292.6	7.5
TOTAL	BILLION \$	-6.2	266.4	715.3	1,192.8	2,168.3	55.6

**TABLE 6.11.7 | OECD ASIA OCEANIA: ACCUMULATED INVESTMENT COSTS FOR RENEWABLE HEAT GENERATION UNDER THE ENERGY [R]EVOLUTION SCENARIO COMPARED TO THE REFERENCE SCENARIO**

ACCUMULATED INVESTMENT COSTS DIFFERENCE REF MINUS E[R]	UNIT	2012-2020	2021-2030	2031-2040	2041-2050	2012-2050	2012 - 2050 AVERAGE PER YEAR
RENEWABLES	BILLION \$	28.5	179.8	192.8	163.5	564.5	14.5

**TABLE 6.11.8 | OECD ASIA OCEANIA: ACCUMULATED INVESTMENT COSTS FOR ELECTRICITY GENERATION AND FUEL COST SAVINGS UNDER THE ADVANCED ENERGY [R]EVOLUTION SCENARIO COMPARED TO THE REFERENCE SCENARIO**

ACCUMULATED INVESTMENT COSTS DIFFERENCE REF MINUS ADVANCED E[R]	UNIT	2012-2020	2021-2030	2031-2040	2041-2050	2012-2050	2012 - 2050 AVERAGE PER YEAR
CONVENTIONAL (FOSSIL + NUCLEAR)	BILLION \$	185.7	332.2	350.9	269.1	1,137.8	29.2
RENEWABLES (INCL. CHP)	BILLION \$	-285.1	-796.4	-659.1	-887.1	-2,627.6	-67.4
TOTAL	BILLION \$	-99.4	-464.3	-308.1	-618.0	-1,489.8	-38.2
<b>ACCUMULATED FUEL COST SAVINGS</b>							
SAVINGS CUMULATIVE ADVANCED E[R] VERSUS REF							
FUEL OIL	BILLION \$	-31.2	-40.5	22.9	45.9	-2.9	-0.1
GAS	BILLION \$	-8.6	137.7	403.5	849.0	1,381.6	35.4
HARD COAL	BILLION \$	20.8	126.6	239.9	275.5	662.7	17.0
LIGNITE	BILLION \$	1.6	11.1	23.6	28.7	65.0	1.7
NUCLEAR ENERGY	BILLION \$	11.4	65.3	96.7	119.2	292.6	7.5
TOTAL	BILLION \$	-6.1	300.2	786.6	1,318.3	2,398.9	61.5

**TABLE 6.11.9 | OECD ASIA OCEANIA: ACCUMULATED INVESTMENT COSTS FOR RENEWABLE HEAT GENERATION UNDER THE ADVANCED ENERGY [R]EVOLUTION SCENARIO COMPARED TO THE REFERENCE SCENARIO**

ACCUMULATED INVESTMENT COSTS DIFFERENCE REF MINUS ADVANCED E[R]	UNIT	2012-2020	2021-2030	2031-2040	2041-2050	2012-2050	2012 - 2050 AVERAGE PER YEAR
RENEWABLES	BILLION \$	28.3	179.9	192.6	148.3	549.2	14.1

# EMPLOYMENT PROJECTIONS - METHODOLOGY AND ASSUMPTIONS

EMPLOYMENT FACTORS

REGIONAL ADJUSTMENTS



“  
just transition:  
investment in  
education rather  
than fossil fuels”

**IMAGE** HUNDREDS OF SALT LAKES ARE SPRINKLED ACROSS THE LANDSCAPE OF NORTHERN AND WESTERN AUSTRALIA. MOST, INCLUDING LAKE MACKAY, FILL INFREQUENTLY VIA SEASONAL RAINFALL THAT RUNS OFF OF NEARBY LANDS AND THROUGH MINOR DRAINAGE CHANNELS. WATER CAN PERSIST IN LAKE MACKAY FOR AT LEAST SIX MONTHS AFTER A FLOOD; WHEN IT DOES, THE EPHEMERAL LAKE PROVIDES AN IMPORTANT HABITAT AND BREEDING AREA FOR SHOREBIRDS AND WATERBIRDS

The Institute for Sustainable Futures at the University of Technology Sydney modelled the effects of the Reference scenario and Advanced Energy {R]evolution Scenario on jobs in the energy sector. This section provides a simplified overview of how the calculations were performed. A detailed methodology is also available.<sup>1</sup> Chapters 6 and 7 contain all the data on how the scenarios were developed. The main inputs to the calculations are:

For each scenario, namely the Reference (business as usual) and Advanced Energy [R]evolution scenario:

- The amount of electrical and heating capacity that will be installed each year for each technology.
- The primary energy demand for coal, gas, and biomass fuels in the electricity and heating sectors.
- The amount of electricity generated per year from nuclear, oil, and diesel.

For each technology:

- Employment factors', or the number of jobs per unit of capacity, separated into manufacturing, construction, operation and maintenance, and per unit of primary energy for fuel supply.

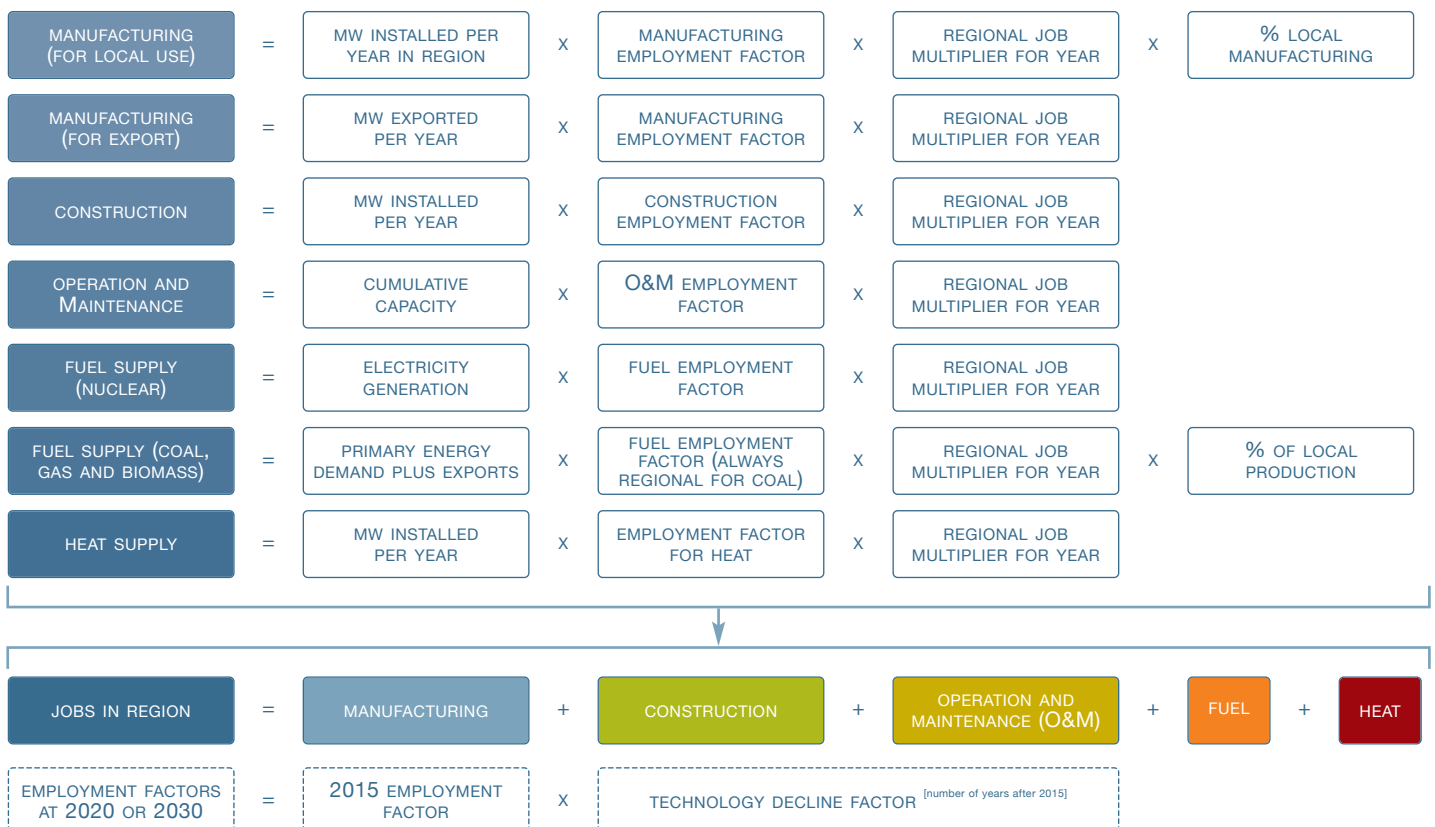
- For the 2020, 2025, and 2030 calculations, a 'decline factor' for each technology which reduces the employment factors by a certain percentage per year. This reflects the fact that employment per unit falls as technology efficiencies improve.

For each region:

- The percentage of local manufacturing and domestic fuel production in each region, in order to calculate the proportion of manufacturing and fuel production jobs which occur in the region.
- The percentage of world trade which originates in each region for coal and gas fuels, and renewable traded components.
- A "regional job multiplier", which indicates how labour-intensive economic activity is in that region compared to the OECD. This is used to adjust OECD employment factors where local data is not available.

The electrical capacity increase and energy use figures from each scenario are multiplied by the employment factors for each of the technologies, and then adjusted for regional labour intensity and the proportion of fuel or manufacturing which occurs locally. The calculation is summarised in the Figure 7.1.

FIGURE 7.1 | METHODOLOGY OVERVIEW



REFERENCES

<sup>1</sup> RUTOVITZ, J., DOMINISH, E. AND DOWNES, J. 2015. CALCULATING GLOBAL ENERGY SECTOR JOBS: 2015 METHODOLOGY UPDATE. PREPARED FOR GREENPEACE INTERNATIONAL BY THE INSTITUTE FOR SUSTAINABLE FUTURES, UNIVERSITY OF TECHNOLOGY SYDNEY.

A range of data sources are used for the model inputs, including the International Energy Agency, US Energy Information Administration, BP Statistical Review of World Energy, US National Renewable Energy Laboratory, International Labour Organisation, World Bank, industry associations, national statistics, company reports, academic literature, and ISF's own research.

These calculations only take into account direct employment, for example the construction team needed to build a new wind farm. They do not cover indirect employment, for example the extra services provided in a town to accommodate the construction team.

The calculations do not include jobs in energy efficiency, although these are likely to be substantial, as the Energy [R]evolution leads to a 34% drop in primary energy demand in the heating and electricity sectors at 2030.

The large number of assumptions required to make calculations mean that employment numbers are indicative only, especially for regions where little data exists. However, within the limits of data availability, the figures presented are representative of employment levels under the two scenarios.

## 7.1 EMPLOYMENT FACTORS

“Employment factors” are used to calculate how many jobs are required per unit of electrical or heating capacity, or per unit of fuel. They take into account jobs in manufacturing, construction, operation and maintenance and fuel. Table 7.1 lists the employment factors used in the calculations. These factors are usually from OECD countries, as this is where there is most data, although local factors are used wherever possible. For job calculations in non OECD regions, a regional adjustment is used where a local factor is not available.

Employment factors were derived for every region for coal supply, because coal is currently so dominant in the global energy supply, and because employment per tonne varies so much by region. In Australia and the US coal is extracted at an average of more than 8,000 tonnes<sup>3</sup> per person per year, while in Europe the average coal miner is responsible for less than 1,000 tonnes per year. India, China, and Eastern Europe/Eurasia have relatively low productivity at present, with 600-700 tonnes per worker per year, but annual increases in productivity are very high. The projections in coal mining employment take into account the trend in

TABLE 7.1 | SUMMARY OF EMPLOYMENT FACTORS USED IN GLOBAL ANALYSIS 2015

	CONSTRUCTION/INSTALLATION JOB YEARS/MW	MANUFACTURING JOB YEARS/MW	OPERATIONS & MAINTENANCE JOBS/MW	FUEL – PRIMARY ENERGY DEMAND
COAL	11.2	5.4	0.14	REGIONAL
GAS	1.3	0.93	0.14	REGIONAL
NUCLEAR	11.8	1.3	0.6	0.001 JOBS / GWh FINAL ENERGY DEMAND
BIOMASS	14.0	2.9	1.5	29.9 JOBS / PJ
HYDRO-LARGE	7.4	3.5	0.2	
HYDRO-SMALL	15.8	10.9	4.9	
WIND ONSHORE	3.2	4.7	0.3	
WIND OFFSHORE	8.0	15.6	0.2	
PV	13.0	6.7	0.7	
GEOHERMAL	11.2	5.4	0.4	
SOLAR THERMAL	1.3	0.93	0.6	
OCEAN	10.2	10.2	0.6	
GEOHERMAL - HEAT	6.9 JOBS/MW (CONSTRUCTION & MANUFACTURING)			
SOLAR - HEAT	8.4 JOBS/MW (CONSTRUCTION & MANUFACTURING)			
NUCLEAR DECOMMISSIONING	0.95 JOBS PER MW DECOMMISSIONED			
COMBINED HEAT AND POWER	CHP TECHNOLOGIES USE THE FACTOR FOR THE TECHNOLOGY, I.E. COAL, GAS, BIOMASS, GEOHERMAL, ETC, INCREASED BY A FACTOR OF 1.5 FOR O&M ONLY.			

note For details of sources and derivation of factors see Rutovitz et al, 2015.<sup>2</sup>

## REFERENCES

- RUTOVITZ, J., DOMINISH, E. AND DOWNES, J. 2015. CALCULATING GLOBAL ENERGY SECTOR JOBS: 2015 METHODOLOGY UPDATE. PREPARED FOR GREENPEACE INTERNATIONAL BY THE INSTITUTE FOR SUSTAINABLE FUTURES, UNIVERSITY OF TECHNOLOGY SYDNEY.
- DATA IS IN TONNES COAL EQUIVALENT, TO STANDARDISE BETWEEN REGIONS.

productivity in India, China, and Russia. Data for the the last 7 to 15 years were used to calculate an annual improvement trend, which has been used to derive an annual percentage reduction in the employment factors for coal mining over the study period.

Local data is also used for gas extraction for every region except India, the Middle East and Other (non-OECD) Asia.

The calculation of coal and gas employment per PJ draws on data from national statistics and company reports, combined with production figures from the BP Statistical review of World Energy 2015<sup>4</sup> or other sources. Data was collected for as many major coal producing countries as possible, with coverage obtained for 90% of world coal production

## 7.2 REGIONAL ADJUSTMENTS

### 7.2.1 REGIONAL JOB MULTIPLIERS

The employment factors used in this model for energy technologies other than coal mining are most often for OECD regions, which are typically wealthier. A regional multiplier is applied to make the jobs per MW more realistic for other parts of the world. In developing countries it typically means more jobs per unit of electricity because those countries have more labour intensive practices. The multipliers change over the study period in line with the projections for GDP per worker. This reflects the fact that as prosperity increases, labour intensity tends to fall. The multipliers are shown in Table 7.3.

### 7.2.2 LOCAL EMPLOYMENT FACTORS

Local employment factors are used where possible. Region specific factors are:

- **OECD North America:** gas and coal fuel, PV and offshore wind (all factors), and solar thermal power (construction and O&M).
- **Other Europe:** gas and coal fuel, offshore wind (all factors), solar thermal power (construction and O&M), and solar heating.
- **OECD Asia Oceania:** gas and coal fuel.
- **Africa:** gas, coal and biomass fuel.
- **China:** gas and coal fuel, and solar heating.
- **Eastern Europe/Eurasia:** gas and coal fuel.
- **Other (non-OECD) Asia:** coal fuel.
- **India:** coal fuel, and solar heating.
- **Latin America:** coal and biomass fuels, onshore wind (all factors), nuclear (construction and O&M), large hydro (O&M) and small hydro (construction and O&M).

TABLE 7.3 | REGIONAL MULTIPLIERS

	2015	2020	2030
OECD	1.0	1.0	1.0
AFRICA	5.7	5.4	4.5
CHINA	2.6	2.1	1.5
OTHER (NON-OECD) ASIA	2.4	2.3	1.9
EASTERN EUROPE/EURASIA	6.0	5.0	3.6
INDIA	6.9	5.9	3.8
LATIN AMERICA	3.4	3.3	2.9
MIDDLE EAST	1.4	1.4	1.2

source Derived from ILO (2013) Key Indicators of the Labour Market, Eighth Edition software, with growth in GDP per capita derived from IEA World Energy Outlook 2014 and World Bank data.

TABLE 7.2 | EMPLOYMENT FACTORS USED FOR COAL FUEL SUPPLY (MINING AND ASSOCIATED JOBS)

	EMPLOYMENT FACTOR JOBS PER PJ	TONNES PER PERSON PER YEAR (COAL EQUIVALENT)	AVERAGE YEARLY PRODUCTIVITY INCREASE 2015 - 2030
OECD NORTH AMERICA	3.8	8,900	NOT CALCULATED
OECD ASIA OCEANIA	4.1	8,380	NOT CALCULATED
OTHER (NON-OECD) ASIA	6.1	5,600	NOT CALCULATED
AFRICA	14.4	2,370	NOT CALCULATED
LATIN AMERICA	15.4	2,200	NOT CALCULATED
WORLD AVERAGE	39.0	875	NOT CALCULATED
OECD EUROPE	40.1	850	NOT CALCULATED
INDIA	48.3	700	5%
EASTERN EUROPE/EURASIA	51.1	670	10%
CHINA	56.1	600	6%
MIDDLE EAST	USED WORLD AVERAGE OF 39.7, AS NO EMPLOYMENT DATA AVAILABLE		

## REFERENCES

4 BP STATISTICAL REVIEW OF WORLD ENERGY 2015.

### **Local manufacturing and fuel production**

Some regions do not manufacture the equipment needed for installation of renewable technologies, for example wind turbines or solar PV panels. The model takes into account a projection of the percentage of renewable technology which is made locally. The jobs in manufacturing components for export are counted in the region where they originate. The same applies to coal and gas fuels, because they are traded internationally, so the model shows the region where the jobs are actually located.

### **Learning adjustments or 'decline factors'**

These account for the projected reduction in the cost of renewable over time, as technologies and companies become more efficient and production processes are scaled up. Generally, jobs per MW would fall in parallel with this trend. The cost projections for each region in the Energy [R]evolution scenarios have been used to derive these factors.

## 7.3 EMPLOYMENT RESULTS BY TECHNOLOGY

### 7.3.1 EMPLOYMENT IN FOSSIL FUELS AND NUCLEAR ENERGY

#### Employment in coal

Jobs in the coal sector drop significantly in both the Reference scenario and the Advanced Energy [R]evolution scenario. In the Reference scenario coal employment drops by 2 million jobs between 2020 and 2030, despite generation from coal nearly doubling. Coal employment in 2015 was close to 9.8 million, so this is in addition to a loss of 0.1 million jobs from 2015 to 2020.

This is because employment per ton in coal mining is falling dramatically as efficiencies increase around the world. For example, one worker in the new Chinese ‘super mines’ is expected to produce 30,000 tonnes of coal per year, compared to current average productivity across all mines in China of about 600 tonnes per year, and average productivity per worker in North America of close to 9,000 tonnes.

Unsurprisingly, employment in the coal sector in the Advanced Energy [R]evolution scenario falls even more between 2020 and 2030, reflecting reduction in coal generation from 34% to 16% of all generation, on top of the increase in efficiency.

Coal jobs in both scenarios include coal used for heat supply.

#### Employment in gas, oil & diesel

Employment in the gas, oil and diesel sectors increases by 12% in the Reference scenario, despite corresponding generation in gas, oil and diesel increasing by 29%. This reflects increasing efficiencies in the sector. In the Advanced Energy [R]evolution scenario, employment and generation remains relatively stable, just above 2015 levels. Gas sector jobs in both scenarios include heat supply jobs from gas.

#### Employment in nuclear energy

Employment in nuclear energy falls by 15% in the Reference scenario between 2020 and 2030, while generation increases by 14%. In the Advanced Energy [R]evolution generation is reduced by 70% between 2020 and 2030, representing a virtual phase out of nuclear power. Employment in the Energy [R]evolution scenario increases slightly, and in 2020 and 2030 is very similar in both scenarios. This is because jobs in nuclear decommissioning replace jobs in generation. It is expected these jobs will persist for 20 - 30 years.

TABLE 7.4 | FOSSIL FUELS AND NUCLEAR ENERGY: CAPACITY AND DIRECT JOBS

	UNIT	2015	2020	REFERENCE SCENARIO		ADV E[R] SCENARIO		
				2025	2030	2020	2025	2030
<b>EMPLOYMENT IN THE ENERGY SECTOR - FOSSIL FUELS AND NUCLEAR</b>								
COAL	THOUSANDS	9,757	9,671	8,634	7,704	4,799	3,279	1,966
GAS, OIL & DIESEL	THOUSANDS	3,581	4,163	4,564	4,667	4,002	4,176	3,978
NUCLEAR ENERGY	THOUSANDS	734	865	828	739	523	519	507
<b>COAL ENERGY</b>								
INSTALLED CAPACITY	GW	1,911	2,164	2,460	2,756	1,854	1,584	1,248
TOTAL GENERATION	TWH	9,732	11,086	12,676	14,266	9,450	8,058	5,873
SHARE OF TOTAL SUPPLY	%	39%	39%	39%	39%	34%	26%	16%
<b>MARKET</b>								
ANNUAL INCREASE IN CAPACITY	GW	-	56	65	64	6	-46	-51
<b>GAS, OIL &amp; DIESEL ENERGY</b>								
INSTALLED CAPACITY	GW	1,990	2,227	2,442	2,655	2,158	2,269	2,324
TOTAL GENERATION	TWH	6,528	6,993	8,004	9,016	7,228	7,329	7,089
SHARE OF TOTAL SUPPLY	%	26%	25%	25%	25%	26%	23%	19%
<b>MARKET</b>								
ANNUAL INCREASE IN CAPACITY	GW	0	28,019	51	50	39	33	22
<b>NUCLEAR ENERGY</b>								
INSTALLED CAPACITY	GW	414	447	471	496	260	184	76
TOTAL GENERATION	TWH	2,744	3,215	3,443	3,670	1,872	1,345	559
SHARE OF TOTAL SUPPLY	%	11%	11%	11%	10%	7%	4%	2%
<b>MARKET</b>								
ANNUAL INCREASE IN CAPACITY	GW	-	8.3	6.0	5.7	-21	-12	-10

### 7.3.2 EMPLOYMENT IN WIND ENERGY AND BIOMASS

#### Employment in wind energy

In the advanced Energy [R]evolution scenario, wind energy provides 21% of total electricity generation by 2030, and employs 8.2 million people. Growth is much more modest in the Reference scenario, with wind energy providing 5% of generation, and employing only 0.6 million people.

#### Employment in biomass

In the Advanced Energy [R]evolution scenario, biomass provides 5.4% of total electricity generation by 2030, and employs 11.5 million people. In the Reference scenario, biomass provides a smaller share of electricity, (2.9%), but employs 11.8 million people, slightly more than in the Advanced Energy [R]evolution Scenario. Jobs in heating from biomass fuels are also included here.

TABLE 7.5 | WINDPOWER: CAPACITY AND DIRECT JOBS

WIND ENERGY	UNIT	2015	2020	REFERENCE SCENARIO		ADV E[R] SCENARIO		
				2025	2030	2020	2025	2030
INSTALLED CAPACITY	GW	380	554	681	807	904	1,873	3,064
TOTAL GENERATION	TWH	794	1,254	1,608	1,962	2,158	4,645	7,737
SHARE OF TOTAL SUPPLY	%	3%	4%	5%	5%	8%	15%	21%
ANNUAL INCREASE IN CAPACITY	GW	-	41	29	28	158	280	302
EMPLOYMENT IN THE ENERGY SECTOR								
DIRECT JOBS IN CONSTRUCTION, MANUFACTURE, OPERATION AND MAINTENANCE	THOUSAND	697	720	760	650	4,218	6,906	8,181

TABLE 7.6 | BIOMASS: CAPACITY AND DIRECT JOBS

BIOMASS ENERGY	UNIT	2015	2020	REFERENCE SCENARIO		ADV E[R] SCENARIO		
				2025	2030	2020	2025	2030
INSTALLED CAPACITY	GW	119	150	174	199	200	295	405
TOTAL GENERATION	TWH	554	740	890	1 039	979	1,505	1,993
SHARE OF TOTAL SUPPLY	%	2.2%	2.6%	2.7%	2.9%	3.5%	4.8%	5.4%
ANNUAL INCREASE IN CAPACITY	GW	0.0	7.1	5.4	5.3	31.8	26.7	26.2
EMPLOYMENT IN THE ENERGY SECTOR								
DIRECT JOBS IN CONSTRUCTION, MANUFACTURE, OPERATION AND MAINTENANCE	THOUSAND	10,970	11,850	12,052	11,762	12,068	12,553	11,544



### 7.3.3 EMPLOYMENT IN GEOTHERMAL AND WAVE POWER

#### Employment in geothermal power

In the Advanced Energy [R]evolution scenario, geothermal power would provide 2% of total electricity generation by 2030, and would employ 386 thousand people. Growth is much more modest in the Reference scenario, with geothermal power providing less than 1% of generation, and employing only 34 thousand people.

#### Employment in wave and tidal power

In the Advanced Energy [R]evolution scenario, wave and tidal power would provide 1% of total electricity generation by 2030, and would employ 652 thousand people. Growth is much more modest in the Reference scenario, with wave and tidal power providing less than 0.1% of generation, and employing only 14 thousand people.

TABLE 7.7 | GEOTHERMAL: CAPACITY AND DIRECT JOBS

GEOTHERMAL	UNIT	2015	2020	REFERENCE SCENARIO		ADV E[R] SCENARIO		
				2025	2030	2020	2025	2030
ENERGY								
INSTALLED CAPACITY	GW	14	17	22	28	31	85	171
TOTAL GENERATION	TWH	93	113	151	188	210	558	1,149
SHARE OF TOTAL SUPPLY	%	0.4%	0.4%	0.5%	0.5%	0.7%	1.5%	2.5%
ANNUAL INCREASE IN CAPACITY	GW	-	0.7	1.2	1.2	7	19	24
EMPLOYMENT IN THE ENERGY SECTOR								
DIRECT JOBS IN CONSTRUCTION, MANUFACTURE, OPERATION AND MAINTENANCE	THOUSAND	32.2	35	33	34.0	181	305	386

TABLE 7.8 | WAVE AND TIDAL POWER: CAPACITY AND DIRECT JOBS

WAVE AND TIDAL POWER	UNIT	2015	2020	REFERENCE SCENARIO		ADV E[R] SCENARIO		
				2025	2030	2020	2025	2030
ENERGY								
INSTALLED CAPACITY	GW	0.6	1.1	2.3	3.6	11.4	46	131
TOTAL GENERATION	TWH	1.4	2.9	6.4	10	32	128	363
SHARE OF TOTAL SUPPLY	%	0.0%	0.0%	0.0%	0.027%	0.1%	0.4%	1.0%
ANNUAL INCREASE IN CAPACITY	GW	0.0		0.4	0.3	4.1		26.4
EMPLOYMENT IN THE ENERGY SECTOR								
DIRECT JOBS IN CONSTRUCTION, MANUFACTURE, OPERATION AND MAINTENANCE	THOUSAND	1.6	4	5	14	232	449	652

### 7.3.4 EMPLOYMENT IN SOLAR PHOTOVOLTAICS AND SOLAR THERMAL POWER

#### Employment in solar photovoltaics

In the Advanced Energy [R]evolution scenario, solar photovoltaic would provide 14% of total electricity generation by 2030, and would employ 10.3 million people. Growth is much more modest in the Reference scenario, with solar photovoltaic providing less than 2% of generation, and employing only 0.7 million people.

#### Employment in solar thermal power

In the Advanced Energy [R]evolution scenario, solar thermal power would provide 7% of total electricity generation by 2030, and would employ 2.7 million people. Growth is much lower in the Reference scenario, with solar thermal power providing only 0.2% of generation, and employing only 80 thousand people.

TABLE 7.9 | SOLAR PHOTOVOLTAICS: CAPACITY AND DIRECT JOBS

SOLAR PHOTOVOLTAICS	UNIT	2015	2020	REFERENCE SCENARIO		ADV E[R] SCENARIO		
				2025	2030	2020	2025	2030
ENERGY								
INSTALLED CAPACITY	GW	186	332	413	494	844	2,000	3,725
TOTAL GENERATION	TWH	214	408	519	630	1,090	2,659	5,067
SHARE OF TOTAL SUPPLY	%	0.9%	1.4%	1.6%	1.7%	3.9%	8.5%	13.7%
ANNUAL INCREASE IN CAPACITY	GW	-	38.0	18.6	17.8	232	326	447
EMPLOYMENT IN THE ENERGY SECTOR								
DIRECT JOBS IN CONSTRUCTION, MANUFACTURE, OPERATION AND MAINTENANCE	THOUSAND	1,015	870	839	661	6,690	11,042	10,322

TABLE 7.10 | SOLAR THERMAL POWER: CAPACITY AND DIRECT JOBS

SOLAR THERMAL POWER	UNIT	2015	2020	REFERENCE SCENARIO		ADV E[R] SCENARIO		
				2025	2030	2020	2025	2030
ENERGY								
INSTALLED CAPACITY	GW	6	11	19	26	42	177	635
TOTAL GENERATION	TWH	13	34	60	85	131	608	2,552
SHARE OF TOTAL SUPPLY	%	0.1%	0.1%	0.2%	0.2%	0.5%	2%	7%
ANNUAL INCREASE IN CAPACITY	GW	0.0	1.5	1.9	1.7	14.9	52	151
EMPLOYMENT IN THE ENERGY SECTOR								
DIRECT JOBS IN CONSTRUCTION, MANUFACTURE, OPERATION AND MAINTENANCE	THOUSAND	26	42	53	80	450	1,664	2,659

### 7.3.5 EMPLOYMENT IN THE RENEWABLE HEATING SECTOR

#### Employment in the renewable heating sector

Employment in the renewable heat sector includes jobs in installation, manufacturing, and fuel supply. This analysis includes only jobs associated with fuel supply in the biomass sector, and jobs in installation and manufacturing for direct heat from solar, geothermal and heat pumps. It is therefore likely to be an underestimate of jobs in this sector.

#### Employment in solar heating

In the Advanced Energy [R]evolution scenario, solar heating would provide 9% of total heat supply by 2030, and would employ 5.6 million people. Growth is much more modest in the Reference scenario, with solar heating providing just over 1% of heat supply, and employing only 0.3 million people.

#### Employment in geothermal and heat pump heating

In the Advanced Energy [R]evolution scenario, geothermal and heat pump heating would provide 7% of total heat supply by 2030, and would employ 1.5 million people. Growth is much more modest in the Reference scenario, with geothermal and heat pump heating providing less than 1% of heat supply, and employing only 37 thousand people.

#### Employment in biomass heat

In the Advanced Energy [R]evolution scenario, biomass heat would provide 24% of total heat supply by 2030, and would employ 5.5 million people. Growth is slightly less in the Reference scenario, with biomass heat providing 18% of heat supply, and employing 5.1 million people.

TABLE 7.11 | SOLAR HEATING: CAPACITY AND DIRECT JOBS

SOLAR HEATING	UNIT	2015	2020	REFERENCE SCENARIO		ADV E[R] SCENARIO		
				2025	2030	2020	2025	2030
ENERGY								
INSTALLED CAPACITY	GW	296	401	503	604	749	1,863	3,421
HEAT SUPPLIED	PJ	1,019	1,386	1,746	2,107	2,676	6,994	12,994
SHARE OF TOTAL HEAT SUPPLY	%	0.7%	0.9%	1.0%	1.2%	1.8%	5%	9%
ANNUAL INCREASE IN CAPACITY	GW	20.5	21	20	20	86	223	312
EMPLOYMENT IN THE ENERGY SECTOR								
DIRECT JOBS IN INSTALLATION AND MANUFACTURE	THOUSAND	363	373	337	312	1,592	3,940	5,637

TABLE 7.12 | GEOTHERMAL AND HEAT PUMP HEATING: CAPACITY AND DIRECT JOBS

GEOTHERMAL AND HEAT PUMP HEATING	UNIT	2015	2020	REFERENCE SCENARIO		ADV E[R] SCENARIO		
				2025	2030	2020	2025	2030
ENERGY								
INSTALLED CAPACITY	GW	100	123	144	166	281	680	1,286
HEAT SUPPLIED	PJ	565	689	810	929	2,134	5,197	10,417
SHARE OF TOTAL HEAT SUPPLY	%	0.4%	0.4%	0.5%	0.5%	1.4%	3%	7%
ANNUAL INCREASE IN CAPACITY	GW	5.0	4.5	4.4	4.3	34.4	80	121
EMPLOYMENT IN THE ENERGY SECTOR								
DIRECT JOBS IN INSTALLATION AND MANUFACTURE	THOUSAND	66	53	43	37	476	992	1,465

TABLE 7.13 | BIOMASS HEAT: DIRECT JOBS IN FUEL SUPPLY

BIOMASS HEAT	UNIT	2015	2020	REFERENCE SCENARIO		E[R] SCENARIO		
				2025	2030	2020	2025	2030
ENERGY								
HEAT SUPPLIED	PJ	28,407	29,818	31,115	32,467	31,404	34,909	36,623
SHARE OF TOTAL HEAT SUPPLY	%	19%	19%	18%	18%	21%	23%	24%
EMPLOYMENT IN THE ENERGY SECTOR								
DIRECT JOBS IN FUEL SUPPLY	THOUSAND	5,150	5,372	5,351	5,136	5,699	5,965	5,487

# THE SILENT ENERGY MARKET [R]EVOLUTION

THE POWER PLANT  
MARKET 1970 TO 2014

THE GLOBAL MARKET SHARES  
IN THE POWER PLANT MARKET:  
RENEWABLES GAINING GROUND

THE FIRST DECADE:  
THE DEVELOPMENT OF THE  
RENEWABLE POWER PLANT MARKET

THE GLOBAL RENEWABLE  
ENERGY MARKET IN 2014



“  
renewables  
gained the  
largest market  
share in 2014”

IMAGE TUNISIA'S SECOND LARGEST CITY, SFAX. SFAX IS A MAJOR PORT AND HOME TO TUNISIA'S LARGEST FISHING FLEET. THE MOST RECOGNIZABLE FEATURES OF SFAX FROM SPACE ARE THE BRILLIANTLY COLORED SALT PONDS SOUTH OF THE OLD CITY AND THE NEW CIRCULAR EARTH WORKS OF THE TAPARURA REDEVELOPMENT PROJECT JUST TO THE NORTH.

### 8.1 THE POWER PLANT MARKET 1970 TO 2011

An analysis of the global power plant market of the past 45 years shows that since the late 1990s, wind and solar installations grew faster than any other power plant technology across the world - about 533,000 MW total capacity between 2000 and 2014. Including all other renewable power technologies (hydro, biomass, concentrated solar and geothermal), a total of 894,000 MW of new capacity has been connected to the grid. However, it is too early to claim the end of the fossil fuel based power generation, because during the same timeframe, almost the same amount of new coal power plants – approx. 840,000 MW – were built with embedded cumulative emissions of around 100 billion tonnes CO<sub>2</sub> over their technical lifetime.

The global market volume of renewable energy in 2014 was, for the first time ever, higher than the global net addition of fossil fuel capacity (REN21-2015).<sup>1</sup> There is a window of opportunity for new renewable energy installations to replace old plants in OECD countries and for electrification in developing countries. However, the window will close within

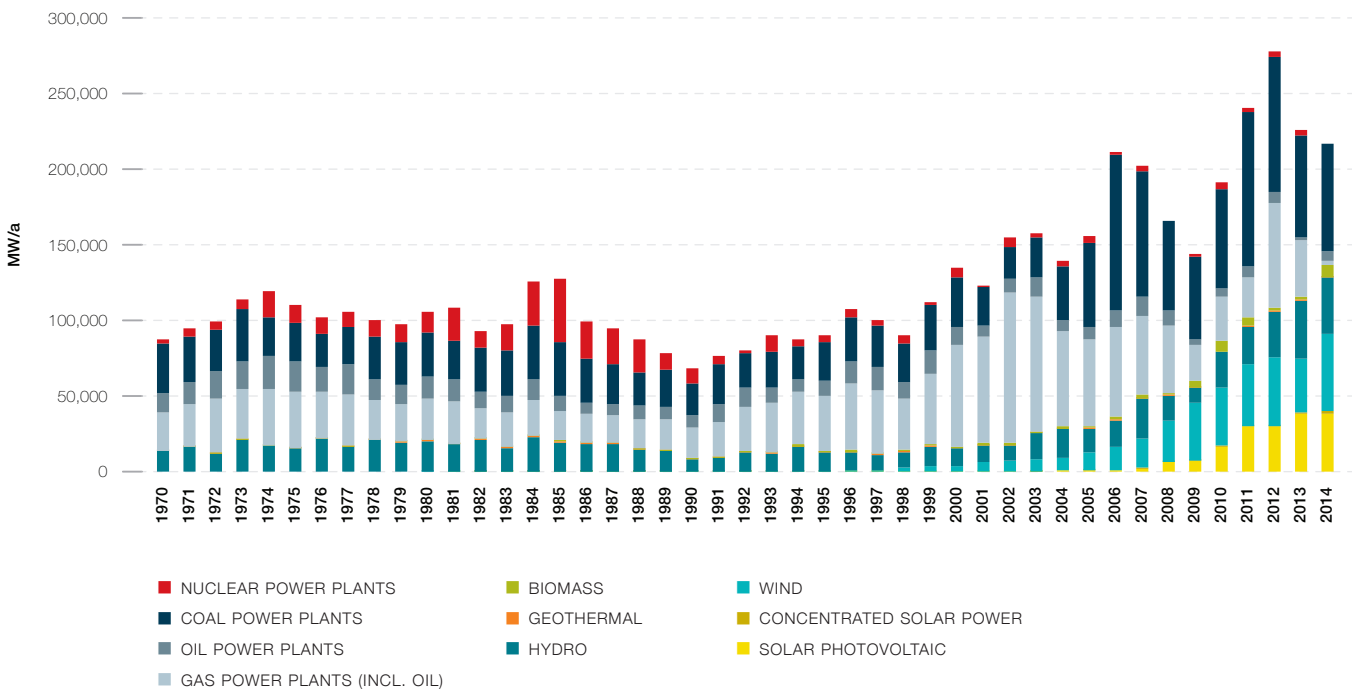
the next few years without good renewable energy policies – especially in regard to priority grid access and dispatching - and legally binding CO<sub>2</sub> reduction targets.

Between 1970 and 1990, the global power plant market in the OECD<sup>2</sup> was dominated by countries that electrified their economies mainly with coal, gas and hydro power plants. The power sector was largely in the hands of state-owned and investor owned utilities with regional or nationwide supply monopolies. The nuclear industry had a relatively short period of steady growth between 1970 and the mid-1980s - with a peak in 1985, one year before the Chernobyl accident - and went into decline in following years, with no signs of growth since then.

Between 1990 and 2000, the global power plant industry went through a series of changes. While OECD countries began to liberalise their electricity markets, electricity demand did not match previous growth, so fewer new power plants were built. Capital-intensive projects with long payback times, such as coal and nuclear power plants, were unable to get sufficient financial support. It was the decade of gas power plants.

8

FIGURE 8.1 | GLOBAL ANNUAL POWER PLANT MARKET 1970 - 2014



source Platts, REN21, EWEA, GWEC, EPIA, National Statistics, IEA, Breyer.  
data compilation Dr. Sven Teske/Greenpeace.

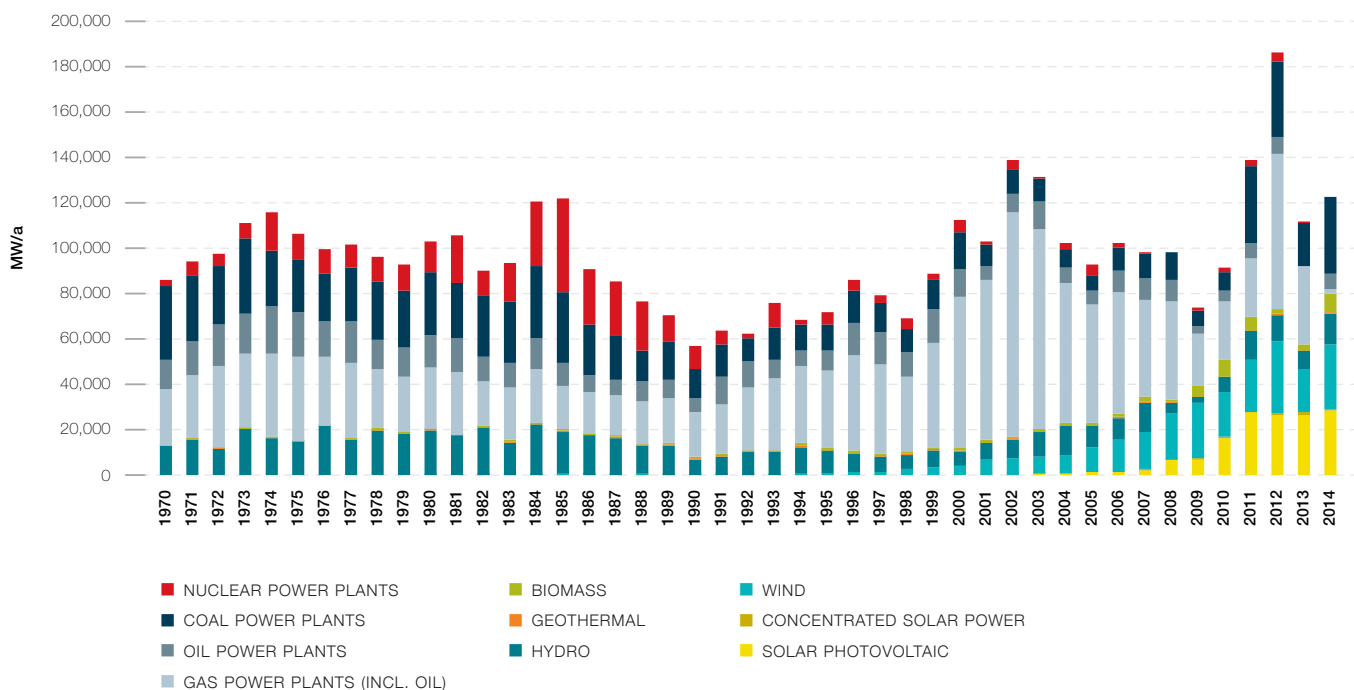
#### REFERENCES

1 (REN21 – 2015); RENEWABLES 2015 -GLOBAL STATUS REPORT; ANNUAL REPORTING ON RENEWABLES: TEN YEARS OF EXCELLENCE; REN21; C/O UNEP; 15, RUE DE MILAN, F-75441 PARIS CEDEX 09, FRANCE; JUNE 2015; WWW.REN21.NET.  
2 (OECD); ORGANISATION FOR ECONOMIC CO-OPERATION AND DEVELOPMENT.

The economies of developing countries, especially in Asia, started growing during the 1990s, triggering a new wave of power plant projects. Similarly to the US and Europe, most of the new markets in the ‘tiger states’ of Southeast Asia partly deregulated their power sectors. A large number of new power plants in this region were built by Independent Power Producer (IPPs), who sell the electricity mainly to state-owned utilities. The majority of new power plant technology in liberalised power markets is fuelled by gas except in China, which focused on building new coal power plants. About 75% of all new coal power plants worldwide between 2000 and

2014 were built in China. In 2014, the first signs that the end of aggressive coal expansion might end appeared: The National Bureau of Statistics of China (NBSC 2015)<sup>3</sup> revealed that the thermal power generation in the first quarter of 2015 was down 3.7%, hydropower generation up 17% and “other” power generation (mainly wind, solar and nuclear) was up 18% on year. Total energy consumption only grew 1% and total electricity consumption was stable. Furthermore, gas-fired capacity grew by 20% during 2014, and coal-power generation fell more than 4%; the overall coal consumption for the power sector declined by as much as 5%.

FIGURE 8.2 | GLOBAL ANNUAL POWER PLANT MARKET – EXCLUDING CHINA: 1970 - 2014



source Platts, REN21, EWEA, GWEC, EPIA, National Statistics, IEA, Breyer.  
data compilation Dr. Sven Teske/Greenpeace.

REFERENCES

3 (NBSC 2015);PRESS RELEASE FROM 15TH APRIL 2015;  
[HTTP://WWW.STATS.GOV.CN/ENGLISH/PRESSRELEASE/201504/T20150415\\_712435.HTML](http://www.stats.gov.cn/english/pressrelease/201504/T20150415_712435.html)

### 8.1.1 POWER PLANT MARKETS IN THE US, EUROPE AND CHINA

The graphs show how much electricity market liberalisation influences the choice of power plant technology. While the US and European power sectors moved towards deregulated markets, which favour mainly gas power plants and increasingly onshore wind, China added large quantities of power generation capacities of various technologies. Besides coal, there was a double digit GW market volume (over 10,000 MW of new capacity per year) for wind and hydro and – since 2013 – solar photovoltaics as well. China was the largest market for PV installations in 2013 and 2014 with no signs of decline in the near future.

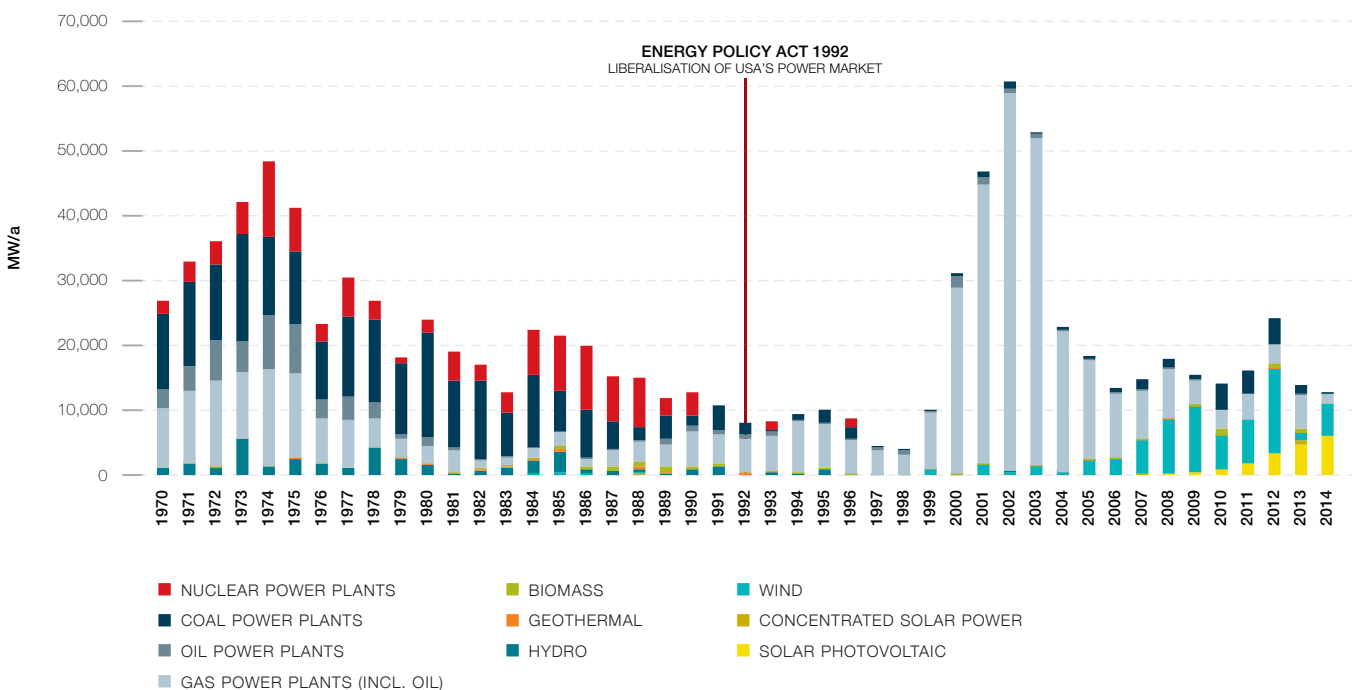
US: Liberalisation of the US power sector started with the Energy Policy Act 1992 and became a game changer for the whole sector. In 2015, the US is still far away from a fully liberalised electricity market, but the effect has been a shift from coal and nuclear towards gas and wind, with a slowly but steadily growing solar photovoltaic market. The economic backbone of the growing onshore wind market has been the

*Production Tax Credit (PTC)* during the past years. The federal renewable electricity production tax credit (PTC) is a per-kWh tax credit for electricity generated by qualified energy resources and sold by the taxpayer to an unrelated person during the taxable year. Originally enacted in 1992, the PTC has been changed numerous times, most recently in January 2013 (USA – energy.gov 2015).<sup>4</sup>

The impact of the PTC on the USA wind market is significant. The United States ranked third for global wind market additions (nearly 4.9 GW), second for cumulative capacity at year's end (65.9 GW), and first for wind power generation (181.8 TWh) during 2014. The US market rebounded with a record 13 GW under construction as of early 2015. Texas led for capacity added (more than 1.8 GW), followed by Oklahoma, Iowa, Washington, and Colorado. The federal PTC, which expired at the end of 2013, was reinstated retroactively in mid-December 2014. The solar photovoltaic market grows mainly due because grid parity has been reached. Net-metering and grid connection regulations are of vital importance for future solar growth.

8

FIGURE 8.3 | USA ANNUAL POWER PLANT MARKET: 1970 - 2014



source Platts, REN21, EWEA, GWEC, EPIA, National Statistics, IEA, Breyer.  
data compilation Dr. Sven Teske/Greenpeace.

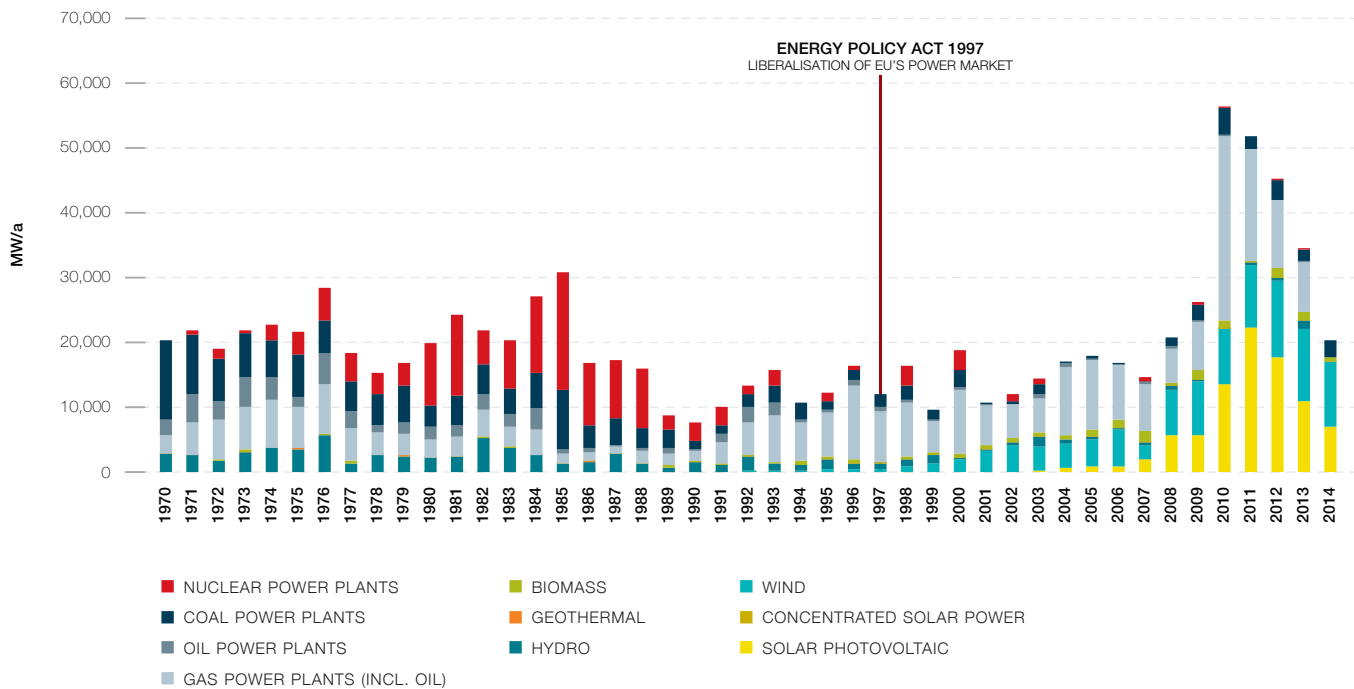
#### REFERENCES

<sup>4</sup> (USA – ENERGY.GOV 2015): OFFICIAL INFORMATION FROM THE WEBSITE OF THE US GOVERNMENT: [HTTP://ENERGY.GOV/SAVINGS/RENEWABLE-ELECTRICITY-PRODUCTION-TAX-CREDIT-PTC](http://energy.gov/savings/renewable-electricity-production-tax-credit-ptc)

**Europe:** About five years after the US began deregulating the power sector, the European Community started a similar process with similar effect on the power plant market. Investors backed fewer new power plants and extended the lifetime of the existing ones. New coal and nuclear power plants have had a market share of well below 10% for new projects since then. The growing share of renewables, especially wind and solar photovoltaics, is due to a legally binding target and the associated feed-in laws in force in many member states of the European Community since the late 1990s. Overall, new installed power plant capacity jumped to a record high because the aged power plant fleet

in Europe needed re-powering. In 1997, the EU established a renewable energy target of 20% by 2020. By mid-2015, it had become clear that this target will be most likely reached and that further energy policy changes – especially for infrastructure – are required. Europe’s grid infrastructure and many power plants are ageing, and major investment decisions are being taken. In October 2014, EU leaders agreed on rather low renewable energy and energy efficiency targets for 2030. The target for a minimum 27 per cent share of renewables across Europe ignores the potential for renewables to supply almost half of Europe’s energy by 2030 and might have a negative impact of the future renewable power market in Europe.

**FIGURE 8.4 | EU ANNUAL POWER PLANT MARKET: 1970 - 2014**



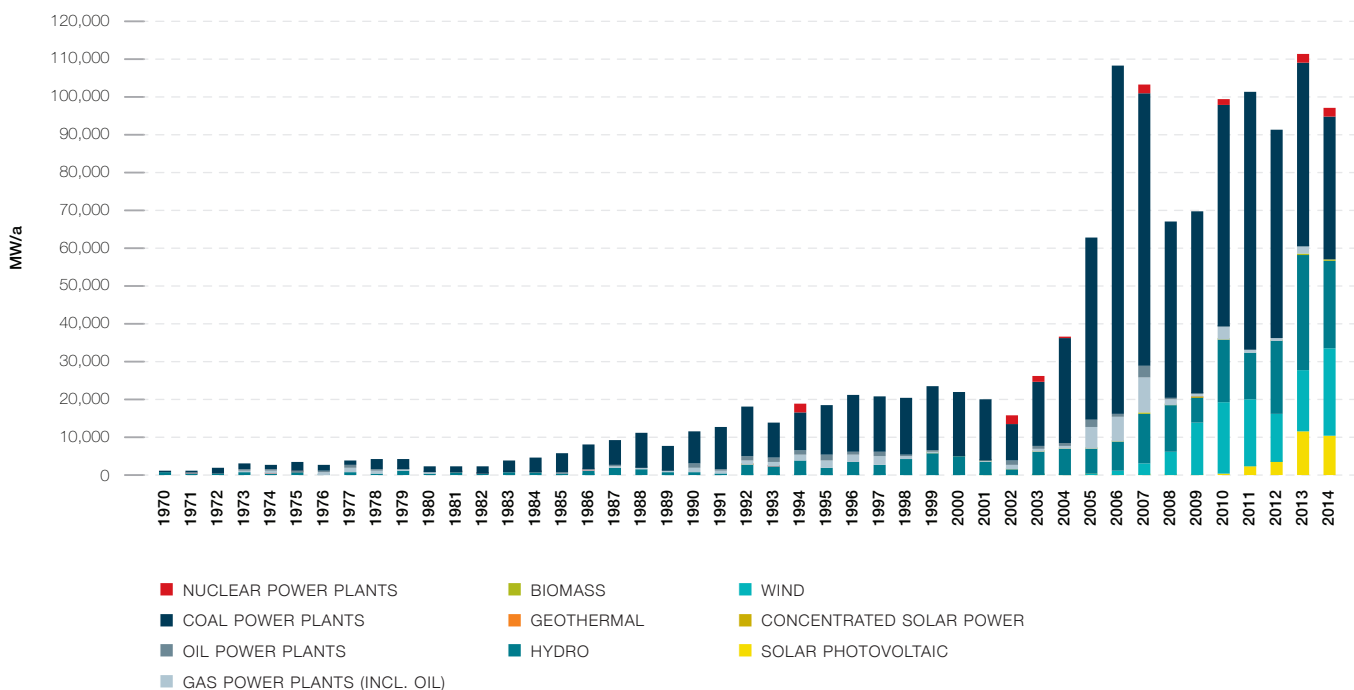
source Platts, REN21, EWEA, GWEC, EPIA, National Statistics, IEA, Breyer.  
data compilation Dr. Sven Teske/Greenpeace.



**China:** The steady economic growth in China since the late 1990s and the growing power demand led to an explosion of the coal power plant market, especially after 2002. In 2013, the market hit a new peak year for new coal power plants: 75% of new coal power plants built worldwide since 2000 were in China. At the same time, China is trying to take its dirtiest plants offline; between 2006 and 2010, a total of 76,825 MW of small coal power plants were phased out under the 11th Five Year Programme. While coal still dominates new added capacity, wind power is rapidly growing as well. Starting in 2003, the wind market doubled each year to over 18,000 MW<sup>5</sup> by 2010, constituting 49% of

the global wind market. The Chinese wind market declined to 12,960 MW in 2012 and increased again to 23,200 MW in 2014. Hydro power plants maintain a large market share for new installations: around 150,000 MW of new capacity has been added, increasing the total installed capacity for hydro to 280,000 MW in China. Solar photovoltaic is starting to play an increasing role with regard to newly installed capacity; 10,600 MW was added in 2014 alone; since 2011, China has added the same capacity of PV as Germany – the world leader – since 1994. Future expansion of renewables depends especially on grid regulation as access to the power grid is the economic basis for renewables.

**FIGURE 8.5 | CHINA ANNUAL POWER PLANT MARKET: 1970 - 2014**



source Platts, REN21, EWEA, GWEC, EPIA, National Statistics, IEA, Breyer.  
data compilation Dr. Sven Teske/Greenpeace.

**REFERENCES**

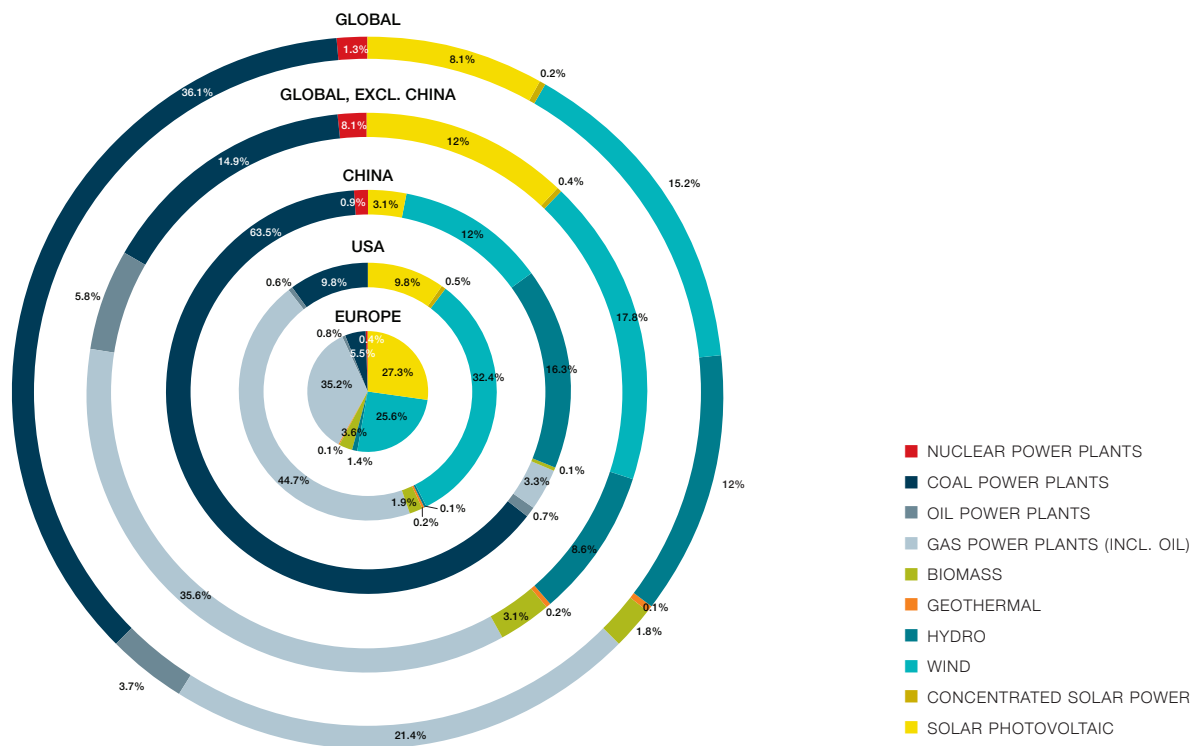
5 WHILE THE OFFICIAL STATISTIC OF THE GLOBAL AND CHINESE WIND INDUSTRY ASSOCIATIONS (GWEC/CREIA) ADDS UP TO 18,900 MW FOR 2010, THE NATIONAL ENERGY BUREAU SPEAKS ABOUT 13,999 MW. THE DIFFERENCES BETWEEN SOURCES ARE DUE TO THE TIME OF GRID CONNECTION, AS SOME TURBINES WERE INSTALLED IN THE LAST MONTHS OF 2010 BUT ONLY CONNECTED TO THE GRID IN 2011. THESE EFFECTS ALSO MIGHT ARISE IN THE FOLLOWING YEAR TILL 2014.

## 8.2 THE GLOBAL MARKET SHARES IN THE POWER PLANT MARKET: RENEWABLES GAINING GROUND

Since 2000, the wind power market gained a growing market share within the global power plant market. Initially only a handful of countries, namely Germany, Denmark and Spain, dominated the wind market, but the wind industry now has projects in over 100 countries around the world. The solar photovoltaic industry has experienced similar growth since 2005. Between 2000 and 2014, 38% of all new power plants worldwide were renewable-powered – mainly wind (15.8%) and PV (8.4%), while 22% were gas power plants and 34% coal. Thus around 60% of all new power plants installed globally are gas power plants and renewable, with close to one-third as coal. Nuclear remains irrelevant on a global scale with just 1% of the global market share for new builds.

The energy revolution has started on a global level already. This picture becomes even clearer when we look into the global market shares but exclude China, the only country with a massive expansion of coal. About 43% of all new power plants since 2000 have been renewables and 37% have been gas power plants (80% gas + RE in total). Coal gained a market share of only 12.5% globally, excluding China. The USA and Europe installed 44% and 59% of renewables, respectively, and 44% and 36% of gas power plants since 2000. Thus new renewables and gas power are the dominating power generation technologies, replacing coal and nuclear and putting both regions on a low-carbon pathway.

FIGURE 8.6 | GLOBAL AND REGIONAL POWER PLANT MARKET SHARES 2004 - 2014<sup>6</sup>



source TESKE 2015.

### REFERENCES

6 (TESKE 2015) MARKET ANALYSIS BASED ON STATISTICS OF PLATTS, REN21, GWEC, SOLARPOWEREUROPE.

### 8.3 THE FIRST DECADE: THE DEVELOPMENT OF THE RENEWABLE POWER PLANT MARKET

The Renewable Energy Network for the 21st Century (REN21) published its 10th in-depth analysis of the Global Renewable Energy Market analysis – “Renewables 2015 – Global Status Report” in June 2015. With the friendly permission of REN21, this section summarizes the main findings of this analysis with regard to renewable power markets and their status in 2014.

#### 8.3.1 THE RENEWABLE POWER SECTOR IN 2014 - REN21'S ANALYSIS

In 2014, most renewable energy projects were developed in the power sector. Including hydropower, which rose by 3.6 percent to around 1,055 GW, renewable electricity capacity increased worldwide to approximately 1,712 GW by the end of 2014. Most of the growth came from non-hydro renewables, which grew by almost 18 percent to an estimated 660 GW. PV and wind posted record capacity additions exceeding new hydropower; taken together, PV and wind made up more than 90 percent of non-hydro added capacity in 2014.

Including fossil and nuclear additions, renewables still made up around 59 percent of the global market, with several countries posting far higher shares. By the end of 2014, 27.7 percent of global generation capacity was renewable, enough to cover 22.8 percent of global power demand, 16.6 percent of which was hydropower. Renewable electricity production is also growing faster than demand. From 2007-2012, electricity consumption grew worldwide by 2.7 percent on average, while renewable power generation increased at an annual rate of 5.9 percent. While electricity consumption in non-OECD countries grew twice as fast as that average, these countries now make up roughly half of investments in renewable energy.

Variable renewables – PV and wind – have also reached high levels of penetration in numerous countries. In 2014, wind power covered 39 percent of power demand in Denmark, 27 percent in Portugal, and 21 percent in Nicaragua. The highest performers with PV were Italy at 7.9 percent of electricity demand, Greece at 7.6 percent, and Germany at seven percent.

The leading countries for total installed renewable power generation capacity at the end of 2014 were China, the United States, Brazil, Germany, and Canada. Roughly a quarter of the world's renewable power capacity was located in China, including some 280 GW of hydropower. Excluding hydropower, the leading countries were China, the United States, and Germany, followed by four countries roughly at the same level: Italy, Spain, Japan, and India. The top 20 countries for non-hydro renewable power capacity per capita were all in Europe. Denmark was far and away the leader, followed by Germany, Sweden, Spain, and Portugal.

Outside China – which added the most wind, solar, and hydropower capacity of any country in the world – there was significant market growth elsewhere in **Asia**. For instance, Thailand added 0.5 GW of PV – more than many European countries – and significant wind power capacity was built in the Philippines and Pakistan.

Renewables made up 78 percent of new generation capacity in the **European Union**, roughly the level of the past seven years. In Germany, the share of non-hydro renewable electricity grew from 10.5 percent in 2010 to 24 percent in 2014. In Scotland, renewables covered nearly half of electricity demand.

In **North America**, PV and wind continued to grow strongly, though the continent has hardly its tremendous resources. More renewable generation capacity was built than gas capacity in the US, and for the first time non-hydro resources produced more electricity than hydropower.

Brazil continues to be the leader with renewables in **Latin America and the Caribbean**. More than 3 GW of hydropower capacity was added in 2014 along with a record 2.5 GW of wind power. But Chile and Mexico also ramped up wind and PV significantly, while Uruguay added the most wind power capacity per capita worldwide.

In Africa, **South Africa** came in ninth worldwide for solar markets, putting the continent in the top 10 for the first time just ahead of India. South Africa also led the continent in wind installations. Kenya built more than half of new global geothermal capacity, and Rwanda added at least 30 MW of hydropower and an 8.5 MW PV plant.

In 2014, large renewable energy projects (more than one megawatt) owned by utilities and key investors continued to dominate global renewable energy production. But Australia, Europe, Japan, and North America have also witnessed significant growth in “prosumers” – power consumers who also produce their own electricity. National dialogues were held in France on how to support and manage this growing group, as did the European Union. In both developed and developing countries, industry also got a lot of the energy is needed from biomass waste from agriculture and forestry.

Development countries with quickly growing energy consumption are developing renewables and fossil fuel capacity simultaneously. In contrast, power consumption is relatively stagnant in numerous OECD countries; they are, renewable energy growth displaces existing generation. Some utilities and power providers in Europe and North America are therefore shedding fossil fuel investments and taking on renewable energy assets – including acquiring other utilities with such assets. Some countries have passed laws requiring utilities to come up with new business models and upgrade grids for the integration of greater shares of renewable electricity. India and Africa in particular are building transmission lines to areas with a lot of renewable energy resources.

Community energy co-ops also grew further in 2014, especially for PV. The first community-owned ocean energy system was built in Scotland, and community projects have also gone up from Thailand to Nova Scotia. Denmark and Germany have the strongest tradition of local ownership of renewable energy projects. As of 2012, 47 percent of renewable energy investments came from citizens in Germany, though that percentage has fallen since then.

In 2014, corporations and large institutions also increasingly got on board. Under the RE100 Initiative, a group of companies pledged to reach 100 percent renewable energy. The total amount that such firms independently invested in renewables added up to billions of dollars. The mining industry has also discovered renewable energy as a way of reducing energy supply costs at remote locations. Mines in Brazil, Canada, Chile, South Africa, and Tanzania now get some of their heat and/or power from renewables.

Traditional utilities are voluntarily purchasing renewable energy, especially electricity, even outside of mandates. In 2013, Germany has 5.7 million residential customers subscribing to 100 percent renewable electricity, up from 0.8 million in 2006. By now, nearly a sixth of private households in the country purchase a total of around 20 TWh of renewable electricity. Additional commercial customers bring green power purchases up to 30 TWh.

Australia, Canada, Japan, South Africa, and the United States also have green power markets. More than half of Americans can subscribe to green power packages from their utility. In the US, 5.4 million customers purchased 62 TWh (roughly 1.7 percent of total US power sales) in 2013.

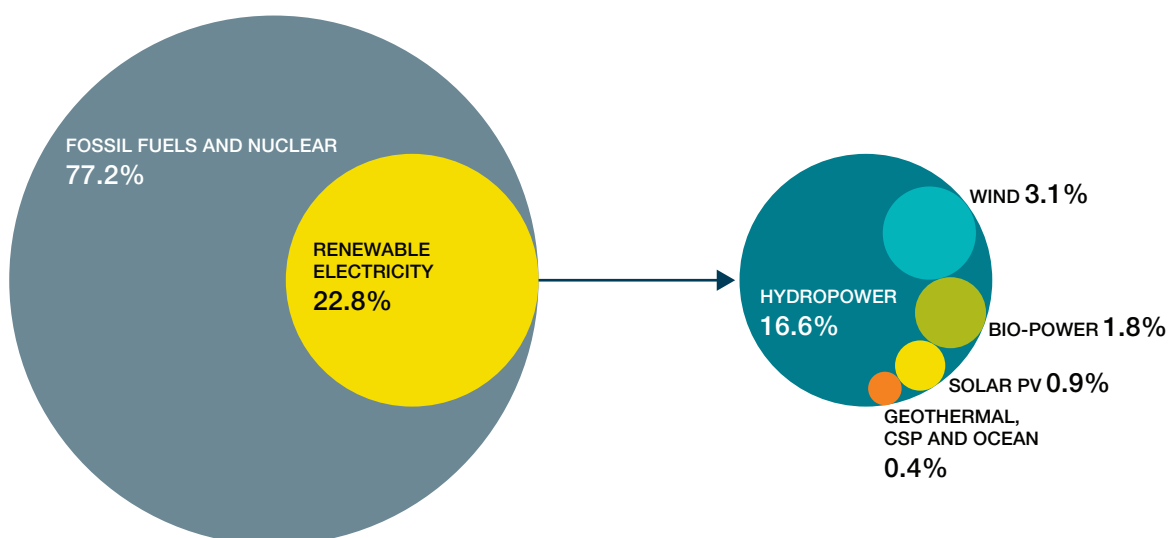
#### 8.4 THE GLOBAL RENEWABLE ENERGY MARKET IN 2014

The heating and cooling sectors have not grown as quickly as renewable electricity. Nonetheless, the market for solar thermal collectors grew by nine percent. In contrast, bio-heat remained nearly unchanged. Heat markets often require district heat networks, for instance, so the infrastructure obstacles are greater. Uncertain policies further impeded the growth of this market.

Electric mobility is moving quickly from a low level. In 2013, the number of electric vehicles doubled to 665,000. E-mobility and battery storage, whose cost is also rapidly dropping, are likely to lead to a breakthrough for renewables and transportation. Biofuels continued to grow, though at a slower pace; the main obstacle here is sustainability. Nonetheless, biofuels remain the primary source of renewable fuel in the transport sector, growing by 8.4 percent to 123.7 billion liters in 2014 (REN21-2015).

Table 8.1 shows the direct connection between strong renewable energy policies and market growth. Up to now, countries with stable, effective policies have had the most success. But as renewable energy becomes cost-competitive and even cheaper than conventional energy, the focus of policymaking will move away from financial incentives towards infrastructure provision, permitting, and levelling the playing field between incumbents and new players.

FIGURE 8.7 | ESTIMATED RENEWABLE ENERGY SHARE OF GLOBAL ELECTRICITY PRODUCTION, END-2014



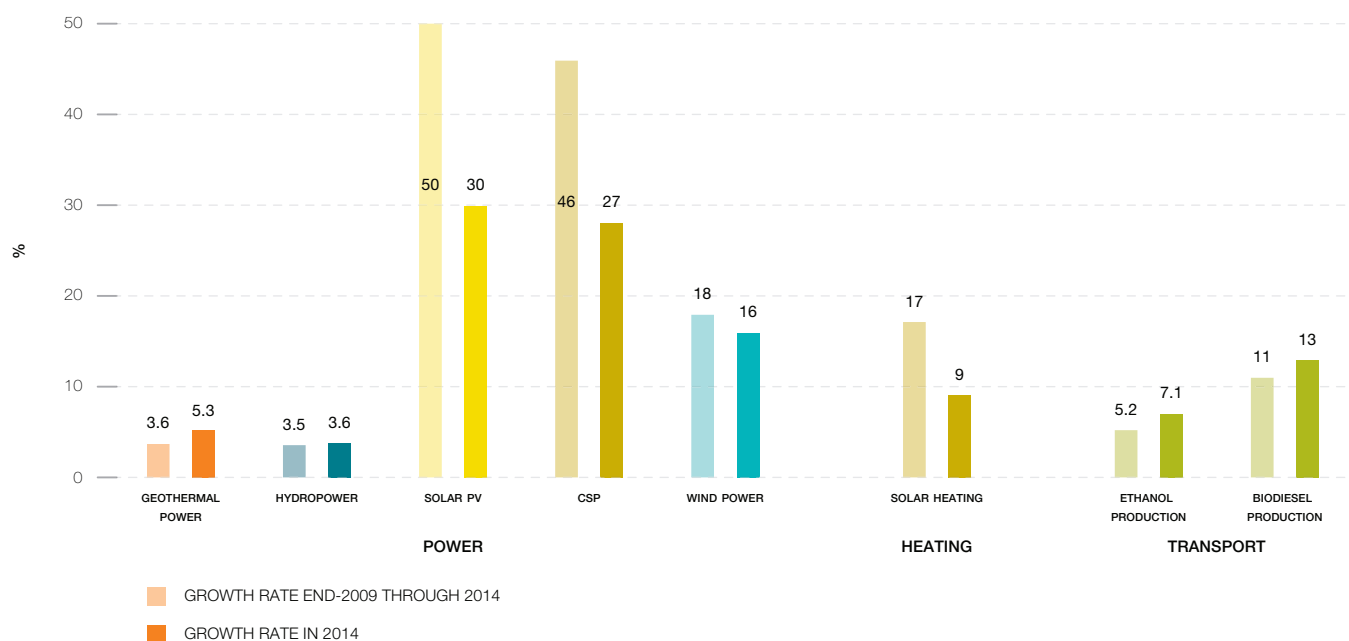
source REN21.

TABLE 8.1 | GLOBAL AND REGIONAL POWER PLANT MARKET SHARES (TESKE 2015)

		START 2004	2013	2014
<b>INVESTMENT</b>				
New investment (annual) in renewable power and fuels	BILLION USD	45	232	270
<b>POWER</b>				
Renewable power capacity (total, not including hydro)	GW	85	560	657
Renewable power capacity (total, including hydro)	GW	800	1,578	1,712
Hydropower capacity (total)	GW	715	1,018	1,055
Bio-power capacity	GW	< 36	88	93
Bio-power generation	TWh	227	396	433
Geothermal power capacity	GW	8.9	12.1	12.8
Solar PV capacity (total)	GW	2.6	138	177
Concentrating solar thermal power (total)	GW	0.4	3.4	4.4
Wind power capacity (total)	GW	48	319	370
<b>HEAT</b>				
Solar hot water capacity (total)	GW <sub>th</sub>	86	373	406
<b>TRANSPORT</b>				
Ethanol production (annual)	BILLION LITRES	28.5	87.8	94
Biodiesel production (annual)	BILLION LITRES	2.4	26.3	29.7
<b>POLICIES</b>				
Countries with policy targets		48	144	164
States/provinces/countries with feed-in policies		34	106	108
States/provinces/countries/ with RPS/quota policies		11	99	99
Countries with tendering/public competitive bidding		N/A	55	60
Countries with heat obligation/mandate		N/A	19	21
States/provinces/countries with biofuel mandates		10	63	64

source REN21-2015.

FIGURE 8.8 | AVERAGE ANNUAL GROWTH RATES OF RENEWABLE ENERGY CAPACITY AND BIOFUELS PRODUCTION, END 2009–2014



source REN21 - 2015.

# ENERGY RESOURCES AND SECURITY OF SUPPLY

## OIL

THE RESERVES CHAOS  
NON-CONVENTIONAL OIL RESERVES

## GAS

SHALE GAS  
COAL

## NUCLEAR

RENEWABLE ENERGY  
REGIONAL RENEWABLE  
ENERGY POTENTIAL

GREENPEACE PRINCIPLES AND  
CRITERIA FOR SUSTAINABLE  
BIOENERGY



“  
the only  
scarcity for  
solar energy  
is the lack of  
political will”

**IMAGE** COASTAL LAGOONS WITH NUMEROUS ROUNDED ISLANDS ARE TYPICAL OF THE INDIAN OCEAN COASTLINE OF WESTERN AUSTRALIA. THESE SHAPES CONTRAST WITH THE ANGULAR, WHITE PONDS OF THE SALT EXTRACTION INDUSTRY. THE AREA HAS EXPERIENCED MORE DIRECT HITS BY CYCLONES THAN ANY OTHER PLACE ON THE WESTERN AUSTRALIA'S COASTLINE. THE REPEATED HITS ALMOST RESULTED IN A DECISION TO PERMANENTLY EVACUATE THE SMALL TOWN OF ONSLOW (JUST OUTSIDE THE IMAGE). MEANWHILE, THE MONTE BELLO ISLANDS OFFSHORE (JUST TO THE NORTH OF THE IMAGE) ARE GUARDED AS DEFUNCT SITES OF ATOMIC BOMB TESTS.

The issue of supply security is at the top of the energy policy agenda. Concern is focused both on price security and the security of physical supply for countries with none of their own resources. In 2013, 78.3% of global final energy demand was met by fossil fuels, while 19.1% came from renewable energy sources and 2.6% from nuclear energy (IEA 2014).<sup>1</sup> The unrelenting increase in energy demand conflicts with the finite nature of these resources. At the same time, the global distribution of oil and gas resources does not match the distribution of demand. Some countries have to rely almost entirely on fossil fuel imports.

The Global Energy Assessment (GEA 2012)<sup>2</sup> is an integrated assessment of the global energy system to date, involving 300 authors and 200 reviewers worldwide, including scientists, policy experts, and industry leaders. Table 1 from that publication shows estimated deposits and the current use of fossil energy resources. There is obviously no shortage of fossil fuels; there might be a shortage of conventional oil and gas, but unconventional resources are still larger than our climate can cope with. Reducing global fossil fuel consumption for reasons of resource scarcity alone is not mandatory, even though there may be substantial price fluctuations and regional or structural shortages as we have seen in the past.

The presently known coal resources and reserves alone probably amount to around 3,000 times the amount currently mined in a year. Thus, in terms of resource potential, current-level demand could be met for many hundreds of years to come. Coal is also relatively evenly spread across the globe; each continent holds considerable deposits. However, the supply horizon is clearly much lower for conventional oil and gas reserves at 40–50 years. If some resources or deposits currently

still classified as ‘unconventional’ are included, the resource potentials exceed the current consumption rate by far more than one hundred years. However, serious ecological damage is frequently associated with fossil energy excavation, particularly oil sands and shale oil.

Over the past few years, new commercial processes have been developed in the natural gas extraction sector, allowing more affordable access to gas deposits previously considered ‘unconventional’, many of which are more frequently found and evenly distributed globally than traditional gas fields. However, tight gas and shale gas extraction can potentially lead to seismic activity and the pollution of groundwater basins and inshore waters. It therefore needs special regulations. A global distribution network for liquid gas already exists, in the form of tankers and loading terminals, so an effective gas market is expected to develop and that oil and gas prices will cease to be linked. Having more liquid gas in the energy mix (currently around 10 % of overall gas consumption) significantly increases supply security, such as by reducing the risks of supply interruptions associated with international pipeline networks.

Gas hydrates are another type of gas deposit found in the form of methane aggregates both in the deep sea and underground in permafrost. They are solid under high pressure and low temperatures. While there is the possibility of continued greenhouse gas emissions from such deposits as a consequence of arctic permafrost soil thaw or a thawing of the relatively flat Siberian continental shelf, there is also potential for extraction of this energy source. Many states, including the USA, Japan, India, China and South Korea have launched relevant research programmes. Estimates of global deposits vary greatly; however, all are in the zettajoule range, for example 70,000–700,000 EJ (Krey et al., 2009).

**TABLE 9.1 | FOSSIL AND URANIUM RESERVES, RESOURCES AND OCCURRENCES<sup>a</sup> (GEA 2012)**

	HISTORICAL PRODUCTION THROUGH 2015 EJ	PRODUCTION 2005 EJ	RESERVES EJ	RESOURCES EJ	ADDITIONAL OCCURRENCES EJ
CONVENTIONAL OIL	6,069	147.9	4,900-7,610	4,170-6,150	
UNCONVENTIONAL OIL	513	20.2	3,750-5,600	11,280-14,800	> 40,000
CONVENTIONAL GAS	3,087	89.8	5,000-7,100	7,200-8,900	
UNCONVENTIONAL GAS	113	9.6	20,100-67,100	40,200-121,900	> 1,000,000
COAL	6,712	123.8	17,300-21,000	291,000-435,000	
CONVENTIONAL URANIUM <sup>b</sup>	1,218	24.7	2,400	7,400	
UNCONVENTIONAL URANIUM	34	N.A.		7,100	> 2,600,000

<sup>a</sup> The data reflect the ranges found in the literature; the distinction between reserves and resources is based on current (exploration and production) technology and market conditions. Resource data are not cumulative and do not include reserves.

<sup>b</sup> Reserves, resources, and occurrences of uranium are based on once-through fuel cycle operation. Closed fuel cycles and breeding technology would increase the uranium resource dimension 50-60 fold. Thorium-based fuel cycles would enlarge the fissile-resource base further.

#### REFERENCES

- 1 (IEA 2014) WORLD ENERGY OUTLOOK 2014; INTERNATIONAL ENERGY AGENCY; 9 RUE DE LA FÉDÉRATION; 75739 PARIS CEDEX 15, FRANCE; WWW.IEA.ORG; NOVEMBER 2014, ISBN: 978 92 64 20804 9
- 2 (GEA 2012): GLOBAL ENERGY ASSESSMENT - TOWARD A SUSTAINABLE FUTURE, CAMBRIDGE UNIVERSITY PRESS, CAMBRIDGE, UK AND NEW YORK, NY, USA AND THE INTERNATIONAL INSTITUTE FOR APPLIED SYSTEMS ANALYSIS, LAXENBURG, AUSTRIA; WWW.GLOBALENERGYASSESSMENT.ORG

The Global Energy Assessment report estimates the theoretical potential to be 2,496 – 2,772,889 EJ (GEA, 2012), i.e. possibly more than a thousand times greater than the current annual total energy consumption. The wide range of this estimation shows the high uncertainty how much of the existing reserves can really be exploited. Approximately a tenth (1,200–245,600 EJ) is rated as potentially extractable. However, the WBGU advised against applied research for methane hydrate extraction, as mining bears considerable risks and methane hydrates do not represent a sustainable energy source ('The Future Oceans', WBGU, 2006).

## 9.1 THE ENERGY [R]EVOLUTION FOSSIL FUEL PATHWAY

The Energy [R]evolution scenario will phase-out fossil fuels not simply as they are depleted, but faster as part of a greenhouse gas reduction pathway required avoiding dangerous climate change. Decisions about opening up new oil, gas and coal mines lead almost certainly to a "lock-in" situation: investments in new oil production will make it more difficult to change to a renewable energy pathway in the future.

The Energy [R]evolution Scenario development aims to organise an energy transition without any new oil exploration and production investments in the Arctic or deep sea wells. Unconventional oil such as Canada's tar sands and Australia's shale oil is not needed to guarantee the supply oil until it is phased out under the Energy [R]evolution scenario (see chapter 5).

### 9.1.1 OIL

Oil is the lifeblood of the modern global economy, as the supply disruptions of the 1970s made clear. Oil is the number one source of energy, providing about one third of the world's needs and the fuel employed almost exclusively for essential uses such as transportation. However, a passionate debate has developed over the ability of supply to meet increasing consumption, a debate obscured by poor information and stirred by recent soaring prices.

#### The reserves chaos

Public information about oil and gas reserves is strikingly inconsistent, and potentially unreliable for legal, commercial, historical and sometimes political reasons. The most widely available and quoted figures, those from the industry journals *Oil & Gas Journal* and *World Oil* have limited value as they report the reserve figures provided by companies and governments without analysis or verification. Moreover, as there is no agreed definition of reserves or standard reporting practice, these figures usually represent different physical and conceptual magnitudes. Confusing terminology - 'proved', 'probable', 'possible', 'recoverable', 'reasonable certainty' - only adds to the problem. Furthermore estimations oil reserves changes sometimes within only a few years significantly: While the BP Statistical Review estimated the total global proven oil reserves by the end of 2010 at 1344 thousand million barrel (BP 2011)<sup>3</sup> only 4 years later the same source increased the estimation to 1701 thousand million barrels (BP 2015).<sup>4</sup>

TABLE 9.2 | POTENTIAL EMISSIONS AS A CONSEQUENCE OF THE USE OF FOSSIL RESERVES AND RESOURCES (GEA 2011)

	HISTORICAL PRODUCTION UP TO 2008 Gt CO <sub>2</sub>	PRODUCTION 2005 Gt CO <sub>2</sub>	RESERVES Gt CO <sub>2</sub>	RESOURCES Gt CO <sub>2</sub>	FURTHER OCCURRENCES Gt CO <sub>2</sub>	TOTAL: RESERVES, RESOURCES AND FURTHER OCCURRENCES	FACTOR BY WHICH THESE EMISSIONS ALONE EXCEED THE 2°C EMISSIONS BUDGET
CONVENTIONAL OIL	505	13	493	386	-	879	1
UNCONVENTIONAL OIL	39	2	295	2,640	3,649	6,584	9
CONVENTIONAL GAS	192	7	339	455	-	794	1
UNCONVENTIONAL GAS	9	1	2,405	3,197	27,724	33,325	44
COAL	666	14	1,970	41,277	-	43,247	58
<b>TOTAL FOSSIL FUELS</b>	<b>1,411</b>	<b>36</b>	<b>5,502</b>	<b>47,954</b>	<b>31,373</b>	<b>84,829</b>	<b>113</b>

Potential emissions as a consequence of the use of fossil reserves and resources. Also illustrated is their potential for endangering the 2°C guard rail. This risk is expressed as the factor by which, assuming complete exhaustion of the respective reserves and resources, the resultant CO<sub>2</sub> emissions would exceed the 750 Gt CO<sub>2</sub> budget permissible from fossil sources until 2050. The figures refer to CO<sub>2</sub> alone, other greenhouse gases have not been taken into account. They are based on the values in Table 9.2. Please note: This table shows corrected values and differs from the printed and earlier pdf versions. Source based on Table 9.1 and GEA 2011.

#### REFERENCES

- 3 (BP 2011) STATISTICAL REVIEW OF THE WORLD - 2011.  
4 (BP 2015 - STATISTICAL REVIEW OF THE WORLD - 2015; WWW.BP.COM.



Historically, private oil companies have consistently underestimated their reserves to comply with conservative stock exchange rules and for reasons of common business prudence. Whenever a discovery was made, only a portion of the geologist's estimate of recoverable resources was reported; subsequent revisions would then increase the reserves from that same oil field over time. National oil companies, mostly represented by OPEC (Organisation of Petroleum Exporting Countries), have taken a very different approach. They are not subject to any sort of accountability, and their reporting practices are even less clear. In the late 1980s, the OPEC countries blatantly overstated their reserves while competing for production quotas, which were allocated as a proportion of the reserves. Although some revision was needed after the companies were nationalised, between 1985 and 1990, OPEC countries increased their apparent joint reserves by 82%. Not only were these dubious revisions never corrected, but many of these countries have reported untouched reserves for years, even if no sizeable discoveries were made and production continued at the same pace. Additionally, the Former Soviet Union's oil and gas reserves have been overestimated by about 30% because the original assessments were later misinterpreted.

Whilst private companies are now becoming more realistic about the extent of their resources, the OPEC countries hold by far the majority of the reported reserves, and their information is as unsatisfactory as ever. Their conclusions should therefore be treated with considerable caution. Fairly estimating the world's oil resources would require a regional assessment of the mean backdated (i.e. 'technical') discoveries.

#### Non-conventional oil reserves

A large share of the world's remaining oil resources is classified as 'non-conventional'. Potential fuel sources such as oil sands, extra heavy oil and oil shale are generally more costly to exploit, and their recovery causes enormous environmental damage. The reserves of oil sands and extra heavy oil worldwide amount to an estimated 6 trillion barrels, 1 to 2 trillion of which are believed to be recoverable if the oil price is high enough and the environmental standards low enough.

One of the worst examples of environmental degradation resulting from the exploitation of unconventional oil reserves is the oil sands beneath the Canadian province of Alberta. They constitute the world's second-largest proven oil reserves after Saudi Arabia. Producing crude oil from these 'tar sands' - a heavy mixture of bitumen, water, sand and clay found beneath more than 54,000 square miles<sup>5</sup> of old-growth forest in northern Alberta, an area the size of England and

Wales - releases up to four times more carbon dioxide, the principal global warming gas, than conventional drilling does. The booming oil sands industry will produce 100 million tonnes of CO<sub>2</sub> a year (equivalent to a fifth of the UK's entire annual emissions) by 2012, ensuring that Canada would have missed its emission targets under the Kyoto Protocol. The oil rush is also scarring a wilderness landscape: millions of tonnes of plant life and top soil are scooped away in vast opencast mines, with millions of litres of water diverted from rivers. Up to five barrels of water are needed to produce a single barrel of crude, and the process requires huge amounts of natural gas. It takes two tonnes of the raw sands to produce a single barrel of oil.

Furthermore the exploitation of tar sands is significantly more expensive than conventional oil production. According to University of Michigan - Center for Sustainable Systems (CSS - 2014)<sup>6</sup> the production cost of oil sands range between 6.6 and 13.1 \$/GJ while conventional oil production costs are estimated between 1.6 to 6.6 \$/GJ. Thus, tar sands are only economical when the price of conventional oil is high. These production costs do not include the enormous environmental and climate damages.

#### 9.1.2 GAS

Natural gas has been the fastest growing fossil energy source over the last two decades, boosted by its increasing share in the electricity generation mix. Gas is generally regarded as an abundant resource; public concerns about depletion are limited to oil, even though few in-depth studies address the subject. Gas resources are more concentrated, and a few massive fields make up most of the reserves. The largest gas field in the world holds 15% of the Ultimate Recoverable Resources (URR), compared to 6% for oil. Unfortunately, information about gas resources suffers from the same bad practices as oil data because gas mostly comes from the same geological formations, and the same stakeholders are involved.

Most reserves are initially understated and then gradually revised upwards, giving an optimistic impression of growth. By contrast, Russia's reserves, the largest in the world, are considered to have been overestimated by about 30%. Owing to geological similarities, gas follows the same depletion dynamic as oil, and thus the same discovery and production cycles. In fact, existing data for gas is of worse quality than for oil, with ambiguities arising over the amount produced, partly because flared and vented gas is not always accounted for. As opposed to published reserves, the technical ones have been almost constant since 1980 because discoveries have roughly matched production.

#### REFERENCES

<sup>5</sup> THE INDEPENDENT, 10 DECEMBER 2007.

<sup>6</sup> (CSS 2014) CENTER FOR SUSTAINABLE SYSTEMS; UNIVERSITY OF MICHIGAN. 2014. "UNCONVENTIONAL FOSSIL FUELS FACTSHEET." PUB. NO. CSS13-19. OCTOBER 2014.

### 9.1.3 SHALE GAS

Natural gas production, especially in the United States, has recently involved a growing contribution from non-conventional gas supplies such as shale gas. Conventional natural gas deposits have a well-defined geographical area. The reservoirs are porous and permeable, and the gas is produced easily through a wellbore. It does not generally require artificial stimulation (INGAA 2008).<sup>7</sup>

Natural gas obtained from unconventional reserves (known as “shale gas” and “tight gas”) requires the reservoir rock to be fractured using a process known as hydraulic fracturing or “fracking”. Fracking is associated with a range of environmental impacts, some of which are not fully characterized or understood. In addition, it appears that the greenhouse gas “footprint” of shale gas production may be significantly greater than of conventional gas, possibly even worse than of coal. In the US, the country with the highest production of shale gas globally, experience shows a huge negative environmental impact (CSS 2014). A single gas well requires one to two hectares of land, in addition to road

networks. The drilling fluid, or “mud,” is used to cool the drill bit, regulate pressure, and remove rock fragments. One well may require hundreds of tonnes of mud and produce 100 to 550 tonnes of rock cuttings. Furthermore, small to moderate magnitude (<6) seismic activity has been linked to underground injection of wastewater produced in oil and gas operations, including a 5.3 and a 5.6 magnitude earthquake in 2011 (CSS 2014).

Research and investment in non-conventional gas resources has increased significantly in recent years due to the rising price of conventional natural gas. In some areas, the technologies for economic production have already been developed, in others it is still at the research stage. Extracting shale gas, however, usually goes hand in hand with environmentally hazardous processes. Even so, it is expected to increase.

**Greenpeace opposes the exploitation of unconventional gas reserves. These resources are not needed to guarantee the needed gas supply under the Energy [R]evolution scenario.**

TABLE 9.3 | ASSUMPTIONS ON FOSSIL FUEL USE IN THE ENERGY [R]EVOLUTION SCENARIO

	2012	2015	2020	2025	2030	2035	2040	2045	2050
<b>CONVENTIONAL OIL</b>									
REFERENCE [PJ/A]	161,342	167,429	176,000	183,891	191,839	196,748	201,700	205,204	208,159
REFERENCE [MILLION BARRELS]	26,363	27,358	28,758	30,048	31,346	32,148	32,958	33,530	34,013
ENERGY [R]EVOLUTION [PJ/A]	161,342	166,364	158,258	138,610	115,473	90,018	66,523	48,024	33,791
ENERGY [R]EVOLUTION [MILLION BARRELS]	26,363	27,184	25,859	22,649	18,868	14,709	10,870	7,847	5,521
ADVANCED ENERGY [R]EVOLUTION [PJ/A]	161,342	166,364	156,426	132,421	103,516	71,952	45,901	27,375	14,744
ADVANCED ENERGY [R]EVOLUTION [MILLION BARRELS]	26,363	27,184	25,560	21,637	16,914	11,757	7,500	4,473	2,409
<b>GAS</b>									
REFERENCE [PJ/A]	118,747	121,555	131,936	145,473	159,631	176,219	193,201	208,781	217,258
REFERENCE [BILLION CUBIC METRES = 10E9M]	3,125	3,199	3,472	3,828	4,201	4,637	5,084	5,494	5,717
ENERGY [R]EVOLUTION [PJ/A]	118,747	122,091	129,644	128,942	125,232	113,681	97,858	74,180	50,419
ENERGY [R]EVOLUTION [BILLION CUBIC METRES = 10E9M]	3,125	3,213	3,412	3,393	3,296	2,992	2,575	1,952	1,327
ADVANCED ENERGY [R]EVOLUTION [PJ/A]	118,747	122,059	130,861	129,841	124,606	107,041	82,188	45,360	8,715
ADVANCED ENERGY [R]EVOLUTION [BILLION CUBIC METRES = 10E9M]	3,125	3,212	3,444	3,417	3,279	2,817	2,163	1,194	229
<b>COAL (HARD COAL + LIGNITE)</b>									
REFERENCE [PJ/A]	154,241	169,064	183,737	198,385	213,587	226,741	240,051	247,154	250,765
REFERENCE [MILLION TONNES]	8,317	8,967	9,641	10,344	11,038	11,656	12,291	12,666	12,853
ENERGY [R]EVOLUTION [PJ/A]	154,241	165,787	161,569	140,973	109,218	75,832	50,437	30,367	17,680
ENERGY [R]EVOLUTION [MILLION TONNES]	8,317	8,773	8,282	6,859	5,040	3,443	2,264	1,342	768
ADVANCED ENERGY [R]EVOLUTION [PJ/A]	154,241	165,997	156,883	131,157	94,693	58,495	33,487	16,826	11,647
ADVANCED ENERGY [R]EVOLUTION [MILLION TONNES]	8,317	8,782	8,078	6,432	4,409	2,690	1,528	753	506

source ?

#### REFERENCES

<sup>7</sup> (INGAA 2008)INTERSTATE NATURAL GAS ASSOCIATION OF AMERICA (INGAA), “AVAILABILITY, ECONOMICS AND PRODUCTION POTENTIAL OF NORTH AMERICAN UNCONVENTIONAL NATURAL GAS SUPPLIES”, NOVEMBER 2008.

#### 9.1.4 COAL

Coal was the world's largest source of primary energy until it was overtaken by oil in the 1960s. Today, coal supplies almost one quarter of the world's energy. However, it is the biggest contributor of carbon emissions among all energy sources, even ahead of oil. Despite being the most abundant of fossil fuels, coal's development is currently threatened by environmental concerns; hence, its future will unfold in the context of both energy security and global warming.

Coal is abundant and more equally distributed throughout the world than oil and gas. Global recoverable reserves are the largest of all fossil fuels, and most countries have at least some. Moreover, existing and prospective big energy consumers like the US, China and India have been self-sufficient in coal, but the situation has changed over the past years. The USA is now a net exporter, while China is a net importer of coal.

While hard coal is a widely used fuel, lignite or brown coal is used only in 18 countries for power generation. This mirrors the available resources. The total reserves for hard coal are estimated with 18,246 EJ (consumption 2013 132.6 EJ/a), while lignite reserves are estimated at 2,775 EJ (consumption 2013 21.6 EJ/a) (GEA 2012).

Coal has been exploited on a large scale for two centuries, so both the product and the available resources are well known; no substantial new deposits are expected to be discovered. Extrapolating the demand forecast forward, the world will consume 20% of its current reserves by 2030 and 40% by 2050. Hence, if current trends are maintained, coal would still last several hundred years.

#### 9.1.5 NUCLEAR

Uranium, the fuel used in nuclear power plants, is a finite resource whose economically available reserves are limited. Its distribution is almost as concentrated as oil and does not match global consumption. Five countries - Canada, Australia, Kazakhstan, Russia and Niger - control three quarters of the world's supply, while on Canada and Russia operate their own nuclear power plants. As a significant user of uranium, however, Russia's reserves will be exhausted within ten years.

Conventional uranium resources are defined as those occurrences from which uranium is recoverable as a primary product, a co-product, or an important by-product. Uranium reserves are periodically estimated by the OECD's Nuclear Energy Agency (NEA) and the International Atomic Energy Agency (IAEA) with input from the World Nuclear Association (WNA), the World Energy Council (WEC), and numerous national geological institutions. NEA-IAEA estimates have the widest coverage, so the reserves reported in their latest survey (the so-called Red Book) are given here (NEA/IAEA, 2014). The two organizations define 'identified reserves' as deposits that could be produced competitively in an expanding market. Until 2008, it included uranium recoverable at less than 130 \$/kgU. Stimulated by high spot prices of up to 350 \$/kg in 2007 (GEA 2012), the 2010 edition of the Red Book extended the cost ranges to 260 \$/kgU, which had not yet further been increased as of 2014 (OECD-NEA 2014).<sup>8</sup>

Secondary sources, such as old deposits, currently make up nearly half of worldwide uranium reserves. However, these will soon be used up. Mining capacities will have to be nearly doubled in the next few years to meet current needs.

A joint report by the OECD Nuclear Energy Agency and the International Atomic Energy Agency<sup>9</sup> estimates that all existing nuclear power plants will have used up their nuclear fuel, employing current technology, within less than 70 years. Given the range of scenarios for the worldwide development of nuclear power, it is likely that uranium supplies will be exhausted sometime between 2026 and 2070. This forecast includes the use of mixed oxide fuel (MOX), a mixture of uranium and plutonium.

The maps on the following pages provide an overview of the availability of different fuels and their regional distribution. Information in this chapter is based partly on the report 'Plugging the Gap',<sup>10</sup> as well as information from the International Energy Agency's World Energy Outlook 2014 and BP Statistical Review 2015.

Map 1 Oil / Map 2: Gas / Map 3: Coal / Map 4: Nuclear / Map 5: Solar / Map 6: Wind

#### REFERENCES

- <sup>8</sup> (OECD NEA-2014) URANIUM 2014: RESOURCES, PRODUCTION AND DEMAND; OECD NUCLEAR ENERGY AGENCY; 12, BOULEVARD DES ÎLES; 92130 ISSY-LES-MOULINEAUX, FRANCE; WWW.OECD-NEA.ORG.  
<sup>9</sup> (OECD NEA 2003) 'URANIUM 2003: RESOURCES, PRODUCTION AND DEMAND'.  
<sup>10</sup> (RES 2007) 'PLUGGING THE GAP - A SURVEY OF WORLD FUEL RESOURCES AND THEIR IMPACT ON THE DEVELOPMENT OF WIND ENERGY', RENEWABLE ENERGY SYSTEMS LTD (RES); BEAUFORT COURT EGG FARM LANE; KINGS LANGLEY HERTS WD4 8LR; UNITED KINGDOM; WEB: WWW.RES-GROUP.COM.

## 9.2 RENEWABLE ENERGY

Nature offers a variety of freely available options for producing energy. Their exploitation is mainly a question of how to convert sunlight, wind, biomass or water into electricity, heat or power as efficiently, sustainably and cost-effectively as possible.

On average, the energy in the sunshine that reaches the Earth is about one kilowatt per square metre worldwide. According to the IPCC Special Report Renewables (SRREN),<sup>12</sup> solar energy reaches the earth at a rate 7,900 times greater than current energy consumption. In one day, the Earth gets enough energy from the Sun to satisfy the world's current energy requirements for twenty years, even before other renewable energy sources such as wind and ocean energy are taken into account. Even though only a percentage of that potential is technically accessible, there is still enough to provide up to ten times more energy than the world currently requires.

The Global Energy Assessment (GEA 2012) report provides a slightly higher estimation of renewable energy resources shown in Table 9.5; however, both sources prove that the availability of the resource on a global scale is not a constraint.

**TABLE 9.4 | RENEWABLE ENERGY POTENTIAL (IPCC – SPECIAL REPORT RENEWABLE ENERGY)**

RENEWABLE SOURCE	ANNUAL FLUX EJ/YR	RATIO (ANNUAL ENERGY FLUX / 2008 PRIMARY ENERGY SUPPLY	TOTAL RESERVE
BIOENERGY	1,548	3.1	-
SOLAR ENERGY	3,900,000	7,900	-
GEOHERMAL ENERGY	1,400	2.8	-
HYDROPOWER	147	0.30	-
OCEAN ENERGY	7,400	15	-
WIND ENERGY	6,000	12	-

source SRREN 2011

### BOX 9.2 | DEFINITION OF TYPES OF ENERGY RESOURCE POTENTIAL<sup>11</sup>

**Theoretical potential:** The physical upper limit of the energy available from a certain source. For solar energy, for example, this would be the total solar radiation falling on a particular surface.

**Conversion potential:** Derived from the annual efficiency of the respective conversion technology, it is therefore not a strictly defined value, since the efficiency of a particular technology depends on technological progress.

**Technical potential:** This takes into account additional restrictions regarding the area realistically available for energy generation. Technological, structural and ecological restrictions and legislative requirements are accounted for.

**Economic potential:** The proportion of the technical potential that can be utilised economically. Biomass, for example, is included if it can be exploited economically in competition with other products and land uses.

**Sustainable potential:** The potential of an energy source is limited based on an evaluation of ecological and socio-economic factors.

**TABLE 9.5 | RENEWABLE ENERGY FLOWS, POTENTIAL, AND UTILIZATION IN EJ OF ENERGY INPUTS PROVIDED BY NATURE**

RENEWABLE SOURCE	UTILIZATION EJ	TECHNICAL POTENTIAL EJ/a	ANNUAL FLOWS EJ/a
BIOMASS, MSW, ETC.	46.3	160-270	2,200
GEOHERMAL	2.3	810-1,545	1,500
HYDROPOWER	11.7	50-60	200
SOLAR ENERGY	0.5	62,000-280,000	3,900,000
WIND ENERGY	1.3	1,250-2,250	110,000
OCEAN ENERGY	-	3,240-10,500	1,000,000

source GEA 2012

#### REFERENCES

<sup>11</sup> WBGU (GERMAN ADVISORY COUNCIL ON GLOBAL CHANGE).

<sup>12</sup> (SRREN 2011) IPCC, 2011: IPCC SPECIAL REPORT ON RENEWABLE ENERGY SOURCES AND CLIMATE CHANGE MITIGATION. PREPARED BY WORKING GROUP III OF THE INTERGOVERNMENTAL PANEL ON CLIMATE CHANGE [O. EDENHOFER, R. PICHSMADRUGA, Y. SOKONA, K. SEYBOTH, P. MATSCHOSS, S. KADNER, T. ZWICKEL, P. EICKEMEIER, G. HANSEN, S. SCHLÖMER, C. VON STECHOW (EDS)]. CAMBRIDGE UNIVERSITY PRESS, CAMBRIDGE, UNITED KINGDOM AND NEW YORK, NY, USA, 1075 PP.

The overall technical potential of renewable energy is several times greater than current total energy demand. Technical potential is defined as the amount of renewable energy output obtainable by full implementation of demonstrated technologies or practices likely to develop. It takes into account the primary resources, the socio-geographical constraints and the technical losses in the conversion process. The complexity of calculating renewable energy potentials is particularly great because these technologies are comparatively young and their exploitation involves changes to the way in which energy is both generated and distributed. The technical potential depends on a number of uncertainties; for instance, a technology breakthrough could have a dramatic impact, changing the technical potential assessment within a very short time frame. Further, because of the speed of technology change, many existing studies are based on out-of-date information. More recent data, such as significantly increased average wind turbine capacity factors and output, would increase the technical potentials still further (SREEN, May 2011).

A wide range of estimates is provided in the literature but studies have consistently found that the total global technical potential for renewable energy is substantially higher than both current and projected future global energy demand. Solar has the highest technical potential amongst the renewable sources, but substantial technical potential exists for all forms (SRREN, May 2011).

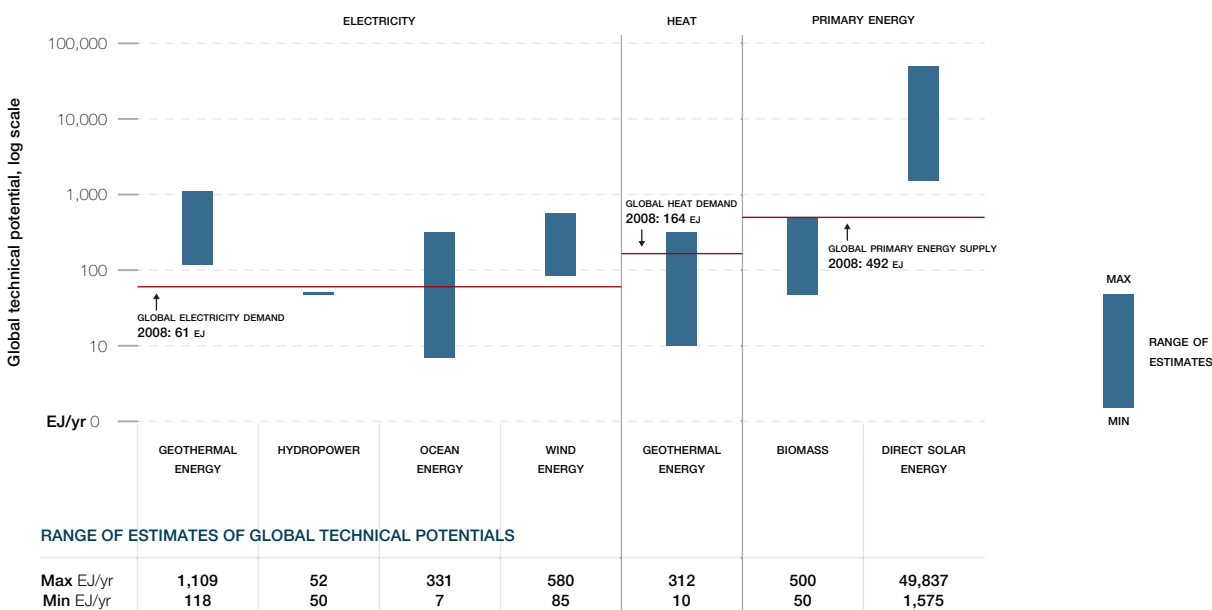
Taking into account the uncertainty of technical potential estimates, Figure 1 provides an overview of the technical potential of various RE resources in the context of current global electricity and heat demand as well as global primary energy supply. Issues related to technology evolution, sustainability, resource availability, land use and other factors that relate to this technical potential are explored in the relevant chapters. The regional distribution of technical potential is addressed in Chapter 10.

The various types of energy cannot necessarily be added together to estimate a total, because each type was estimated independently of the others (for example, the assessment did not take into account land use allocation; for instance, PV and concentrating solar power cannot occupy the same space when a particular site is suitable for either).

Given the large unexploited resources, even without having reached the full development limits of the various technologies, it can be concluded that the technical potential is not a limiting factor in the expansion of renewable energy generation. It will not be necessary or desirable to exploit the entire technical potential. Implementation of renewable energy has to respect sustainability criteria in order to achieve a sound future energy supply. Public acceptance is crucial, especially bearing in mind that the decentralised character of many renewable energy technologies will move systems closer to consumers. Without public acceptance, market expansion will be difficult or even impossible.

9

FIGURE 9.1 | GLOBALLY AVERAGED COMBINED LAND AND OCEAN SURFACE TEMPERATURE ANOMALY



source SRREN 2011

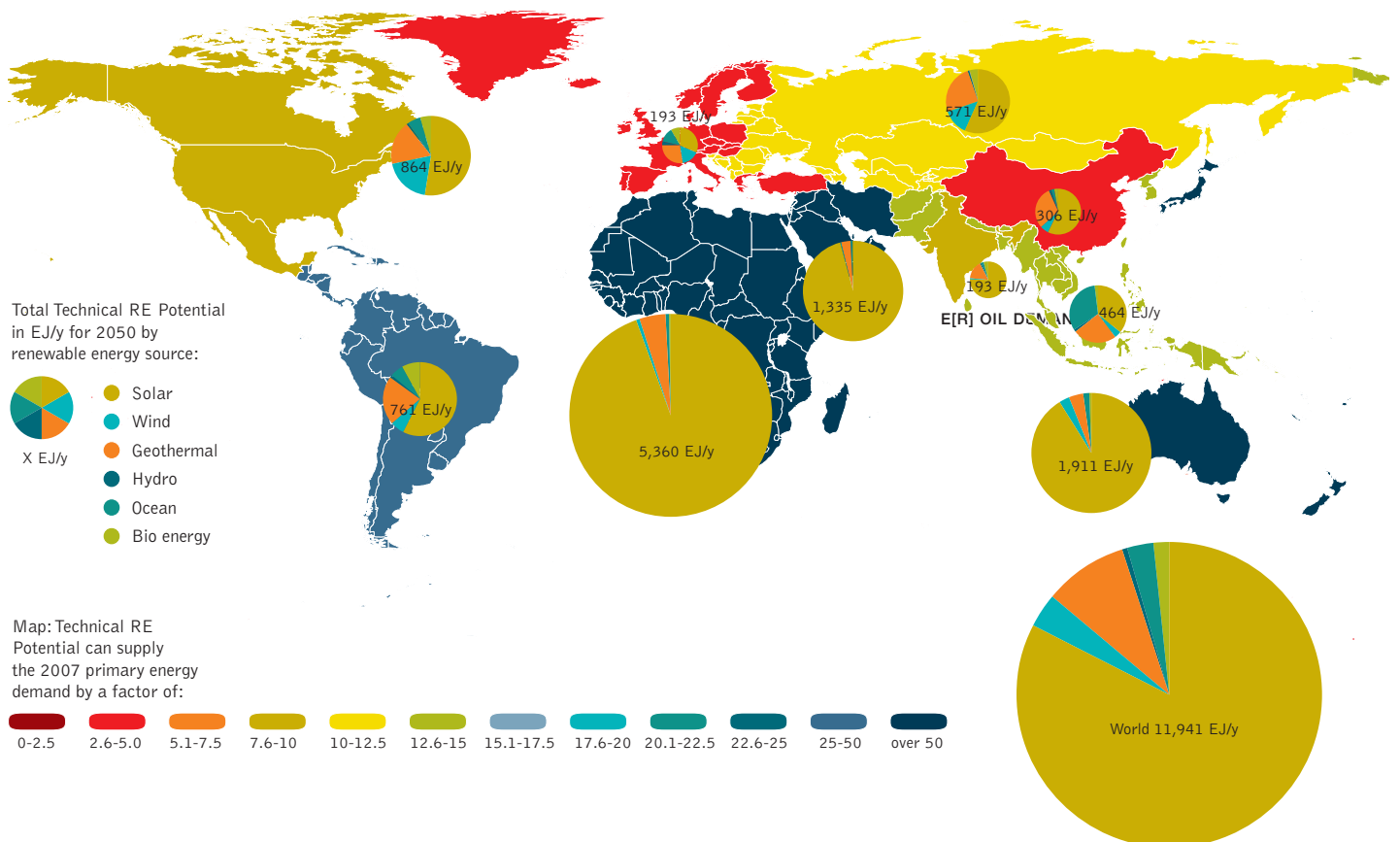
note Biomass and solar are shown as primary energy due to their multiple uses. Note that the figure is presented in logarithmic scale due to the wide range of assessed data.

In addition to the theoretical and technical potential discussions, this report also considers the economic potential of renewable energy sources, taking into account all social costs and assuming perfect information (covered in Section 10.6) and the market potential of RE sources. Market potential is defined in Box 9.2, but the term often used in different ways. The general understanding is that market potential means the total amount of renewable energy that can be implemented in the market, taking into account existing and expected real-world market conditions (covered in Section 10.3) shaped by policies, availability of capital and other factors, each of which is discussed in AR4 and defined in Annex I. The market potential may therefore in theory be larger than the economic potential. To be realistic, however,

market potential analyses have to take into account the behaviour of private economic agents under specific prevailing conditions, which are of course partly shaped by public authorities. The energy policy framework in a particular country or region will have a profound impact on the expansion of renewables.

Before looking at the possible regional contribution renewable energy can make, it is worth understanding the upper limits of the regional potential of each source to develop an optimal mix in terms of technical and economic circumstances.

FIGURE 9.2 | RENEWABLE ENERGY POTENTIAL ANALYSIS



source IPCC/SRREN.

**note** The technical RE potentials reported here represent total worldwide and regional potentials based on a review of studies published before 2009 by Krewitt et al. (2009). They do not deduct any potential already utilized for energy production. Due to methodological differences and accounting methods among studies, these estimates cannot be strictly compared across technologies and regions, nor in terms of primary energy demand. Technical RE potential analyses published after 2009 show higher results in some cases but are not included in this figure. Some RE technologies may compete for land, possibly lowering the overall RE potential. Scenario data: IEA WEO 2009 Reference scenario (International Energy Agency (IEA), 2009; Teske et al., 2010), ReMIND-RECIPE 450ppm Stabilization Scenario (Luderer et al., 2009), MiniCAM EMF22 1st-best 2.6 W/2 Overshoot Scenario (Calvin et al., 2009), Advanced Energy [R]evolution 2010 (Teske et al., 2010).

### 9.3 GREENPEACE PRINCIPLES AND CRITERIA FOR SUSTAINABLE BIOENERGY

Clearly, the biggest potential that the terrestrial environment offers for climate change mitigation lie in a radical change in the way we use land resources and not in just maximizing the amount of biomass available to burn. Strict criteria for bioenergy, adequate policies, institutional frameworks and enforcement capacities are needed to safeguard environmental, climate and social benefits and ensure that this scarce resource is used in the most effective manner. This must include the following principles and criteria (in random order):

#### PRINCIPLES

- Bioenergy production must not cause negative impacts on the world's natural capital, such as forests and other natural ecosystems, biodiversity, soil fertility and water resources.
- Bioenergy production must not cause negative impacts on livelihoods, nor on people's access to nutritious and healthy food. Land and water grabbing, land use conflicts and other social conflicts must be prevented.
- Bioenergy must not widen social inequalities between developing and developed countries. International trade in biomass or biofuels must not undermine food security. Production for local needs should take priority over production for the global market.
- Bioenergy production must be as resource efficient as possible, and deliver significant reductions in greenhouse gas emissions compared to fossil fuel-based energy systems.
- Biomass must be utilized for energy following the cascading use principle. Under this principle biomass is preferably used for maintaining soil fertility, food, feed and materials that store carbon.<sup>13</sup> Bioenergy should not compete with these sectors for biomass feedstock. Policies that incentivize the production of bioenergy (and thereby create a market) must enhance instead of distort the cascading use of biomass.
- In order to close nutrient cycles and reduce CO<sub>2</sub> emissions, bioenergy should preferably be produced from regionally available biomass and satisfy regional energy need.
- Energy demand reductions must be prioritised so as to reduce the volume of bioenergy required to secure a supply of 100% renewable energy.
- Biomass for bioenergy should preferably be utilized in applications where it delivers the highest CO<sub>2</sub> savings.
- Bioenergy for electricity should be used for dispatching and not for large base load capacity.

#### CRITERIA

##### Greenhouse gas emissions

- Any bioenergy project should replace energy produced from fossil fuels. Considering the entire production chain, above-ground and below-ground carbon stock changes and any indirect land use changes (ILUC), the net greenhouse gas emission reduction of such a project must be at least 50% compared to a natural gas reference, 60% compared to an oil reference and 70% compared to a coal reference. This net emission reduction must be realized within 20 years.<sup>14</sup>
- Greenhouse gas emissions as a result of Indirect Land Use Change (ILUC) must be integrated in the greenhouse gas calculation methodology of crops (including trees) for bioenergy, grown on agricultural land, by determining crop-specific ILUC-factors.
- Whether commercial, non-commercial, diseased or fire-damaged, standing trees from (semi)natural forests must not be cut specifically for bioenergy because of the large upfront carbon debt that is created.
- Tree harvest levels in forests must not be increased as a result of bioenergy production.
- Land with a high carbon stock (forests, woodlands, peatlands, grasslands) must not be converted.<sup>15, 16</sup>

##### Biodiversity

- Bioenergy production must not be extracted from High Conservation Value Areas (HCVAs) and must not cause direct or indirect destruction, conversion or degradation of valuable ecosystems, such as forests, woodlands, peatlands and grasslands.
- Bioenergy production must not cause a loss of biodiversity in agro-ecosystems.
- In forests that are managed for wood production, woody biomass should only be used for bioenergy production if it is proven to be sourced from responsibly managed forests and plantations, equivalent to or exceeding the standard of the Forest Stewardship Council (FSC).<sup>17</sup>
- No deliberate release of genetically engineered (GE) organisms to the environment must be permitted. Any bioenergy crops, including trees, must not be GE. GE microbes (including those developed by synthetic biology) must only be used in securely-contained facilities.

#### REFERENCES

- <sup>13</sup> GREENPEACE DOES NOT NECESSARILY VALUE FEED ABOVE ENERGY. THE LIVESTOCK SECTOR IS LARGELY UNSUSTAINABLE AND SHOULD BE STRONGLY DECREASED IN MOST PARTS OF THE WORLD. HOWEVER, THE COMPETITION EFFECT OF A POLICY DRIVEN BIOENERGY MARKET WITH THE FOOD AND FEED MARKET LEAD TO UNCONTROLLABLE NEGATIVE EFFECTS, MAINLY INDIRECT LAND USE CHANGE (ILUC), WHICH CAN UNDERMINE THE ENVIRONMENTAL BENEFITS OF BIOENERGY.
- <sup>14</sup> THE CALCULATION MUST INCLUDE EMISSIONS FROM CULTIVATION, EXTRACTION, PROCESSING, STORAGE, TRANSPORT, AND SMOKESTACK EMISSIONS (BURNING BIOMASS IS NOT CARBON NEUTRAL). WHEN BURNING BIOMASS, THE NET GREENHOUSE GAS EMISSIONS OVER A PERIOD OF 20 YEARS MUST BE ACCOUNTED FOR, AGAINST THE REFERENCE SCENARIO OF NOT USING THE BIOMASS FOR BIOENERGY.
- <sup>15</sup> GRASSLANDS STORE APPROXIMATELY 34% OF THE GLOBAL STOCK OF CARBON IN TERRESTRIAL ECOSYSTEMS WHILE FORESTS STORE APPROXIMATELY 39%.
- <sup>16</sup> GREENPEACE (2013), IDENTIFYING HIGH CARBON STOCK (HCS) FOREST FOR PROTECTION. [HTTP://M.GREENPEACE.ORG/INTERNATIONAL/GLOBAL/INTERNATIONAL/BRIEFINGS/FORESTS/2013/HCS-BRIEFING-2013.PDF](http://m.greenpeace.org/international/global/international/briefings/forests/2013/hcs-briefing-2013.pdf)
- <sup>17</sup> AT THIS MOMENT, ONLY THE FSC PRINCIPLES AND CRITERIA ARE SUFFICIENT TO GUARANTEE RESPONSIBLE MANAGEMENT OF FORESTS. SEE [WWW.FSC.ORG](http://www.fsc.org). THIS APPLIES TO ALL WOOD PRODUCTS, WHETHER BIOENERGY IS INVOLVED OR NOT.

- Crops and plantations must protect, conserve and restore native biodiversity on farm level, which means that they must not concentrate on monocultures.
- The expansion and development of new bioenergy crops, plantations and/or tree plantings, must not introduce any invasive species. Where there is doubt, the precautionary principle must be applied.

## Environment

- The production of bioenergy from crops or residues must maintain ecosystem services: water filtration, water quality and quantity, nutrient recycling, soil organic carbon, overall soil fertility and pollination.
- Ecological farming practices must be applied that do not pollute the biosphere through the accumulation of agrochemicals, such as synthetic fertilizers, pesticides and herbicides, in the soil, water or air. The use of agrochemicals must be minimised and ultimately phased out, which means that their use must be limited to when there is no biological or organic alternative and to only the most-efficient and non-polluting methods.<sup>18</sup>

## Social justice

- Bioenergy production must not cause direct or indirect destruction of, or transfer of land away from existing peasant, indigenous, and/or nomadic agricultural/agropastoral/pastoral systems.
- Local food security, livelihoods, stakeholder rights and land rights by local communities who live off the land must be respected and strengthened, in line with the tenure guidelines of the UN Committee on World Food Security (CFS).<sup>19</sup>
- Indigenous peoples and local communities must have the right to free and prior informed consent for the use of their land.
- Labour rights must be respected according to the International Labour Organization (ILO) standards.<sup>20</sup>

## Verification and transparency

- Above criteria must be verified by an accredited and transparent third party to prove that these criteria are met.
- Information about the volume, specific feedstock and feedstock origin of the bioenergy that each individual energy company brings to the market must be publicly available.

## 9.3.1 POLICY RECOMMENDATIONS

Bioenergy can only be ecologically sound if coming from sustainable and responsible sources and land uses. Large scale bioenergy production currently leads to uncontrollable negative impacts because most land is not managed in a sustainable way. This is why Greenpeace foresees a relatively small role for bioenergy in the transition towards 100% renewable energy. The constraints in the sphere of governance are too complex to realistically adopt and promote a large role for bioenergy in a socially and ecological sustainable way. Greenpeace advises governments and companies to be very cautious with policies related to bioenergy, to apply all the principles and criteria listed in this document and to make sure that acquisition of bioenergy feedstock does not lead to damage to ecosystems, avoids competition with soil fertility maintenance, food production and the production of materials that store carbon. The precautionary principle should guide the development and implementation of bioenergy policies. The enforcement of a robust institutional framework must prevent negative social and environmental impacts. Governments must prioritize sustainable land use policies, from ecological farming to effective forest protection.

## 9.3.2 BIOENERGY AND CLIMATE

The international accounting rules for greenhouse gas emissions, as agreed upon within the United Nations Framework Convention on Climate Change (UNFCCC) contain a major flaw regarding accounting for the greenhouse gas emissions of bioenergy. Greenhouse gas emissions due to Land Use, Land Use Change and Forestry (LULUCF) should be reported in the national greenhouse gas inventories of Annex 1 parties under the Kyoto protocol. Subsequently, smokestack greenhouse gas emissions from biomass combustion are set to zero, to avoid double counting. However, in practise a lot of biomass that is burned in Annex 1 countries comes from non-Annex 1 countries and not all Annex 1 countries report LULUCF emissions. Furthermore, while reporting Land Use and Land Use Changes emissions is mandatory for Annex 1 countries, reporting Forestry emissions is only optional. On top of that, due to Indirect Land Use Change (ILUC), land use change is taking place in non-Annex 1 countries, as a result of bioenergy policies in Annex 1 countries. Despite this, all bioenergy is accounted for as climate neutral leading to an enormous carbon accounting error. Therefore, carbon accounting schemes should stop assuming 'carbon neutrality' of bioenergy and account for the net direct and indirect greenhouse gas performance of bioenergy as outlined in the sustainability criteria for bioenergy presented in this document.

## REFERENCES

- <sup>18</sup> OBVIOUSLY THIS APPLIES TO ALL AGRICULTURE, WHETHER BIOENERGY PRODUCTION IS INVOLVED OR NOT.  
<sup>19</sup> UNITED NATIONS (UN) COMMITTEE ON WORLD FOOD SECURITY (CFS) (2012), VOLUNTARY GUIDELINES ON THE RESPONSIBLE GOVERNANCE OF TENURE OF LAND, FISHERIES AND FORESTS IN THE CONTEXT OF NATIONAL FOOD SECURITY, [HTTP://WWW.FAO.ORG/CFS/CFS-HOME/CFS-LAND-TENURE/EN/](http://www.fao.org/cfs/cfs-home/cfs-land-tenure/en/).  
<sup>20</sup> INTERNATIONAL LABOUR ORGANIZATION (ILO), INTERNATIONAL LABOUR STANDARDS, [HTTP://WWW.ILO.ORG/GLOBAL/STANDARDS/LANG-EN/INDEX.HTM](http://www.ilo.org/global/standards/lang-en/index.htm).



### Bioenergy and sustainable land use

- Agriculture has to be based on sustainable land use management practices. A shift is needed from industrial agriculture towards ecological farming based on closed nutrient and water cycles. Agricultural residues can only be used for bioenergy in limited amounts. Policies that promote bioenergy made from agricultural residues should not enhance unsustainable industrial agriculture.
- In countries that produce forest biomass, governments should impose strict biomass sourcing policies that would stop companies from cutting down standing trees for energy production.
- Livestock production uses 75% of agricultural land, including both the land used to grow crops for animal feed and pasture and grazing lands. Whether there will be space for growing dedicated energy crops on agricultural land in a responsible way in the future depends, amongst many other factors, on the development of the diet of populations around the world. Consuming less animal protein reduces significantly the surface of agricultural land needed for food production. Policies are therefore needed that disincentivise animal protein consumption.

### Bioenergy and the energy transition

- Access to clean renewable energy must be delivered for all. Apart from being inefficient and time consuming, most traditional use of biomass in developing countries leads to respiratory problems for its users and degradation of forests and woodland resources, as well as soil erosion and degradation. Clean energy access must therefore be prioritized for communities that still depend on traditional biomass for cooking and heating. This is a 'low-hanging fruit' that could combine a strong increase in welfare with environmental protection and nature conservation.
- According to the polluter-pays-principle, subsidies for bioenergy production must not make fundamentally unsustainable industries more competitive. Examples are co-firing of biomass with coal in coal-fired power plants or digestion of animal manure produced by intensive livestock operations for meat and dairy production. The latter must be required to mitigate methane emissions, but this should not be subsidized.
- In biomass importing countries, governments should not rely on bioenergy for meeting renewable energy targets. The share of bioenergy must be capped.
- In biomass-importing countries, governments should not rely on bioenergy for meeting renewable energy targets. The share of bioenergy must be capped.
- The transition to 100% renewable energy entails a radical system change, and bioenergy policies should not block nor delay this change. Replacing gasoline and diesel with biofuels within the infrastructure of the oil industry and within inefficient internal combustion engines does not trigger a system change, nor does replacing coal with wood in coal power plants.
- Sustainable bioenergy, which is an inherently a limited available energy source, should be part of a long term strategy that leads to 100% renewable energy. Sustainable bioenergy should not be utilized for large-scale base load electricity production, but for dispatching in the electricity sector, heat production and as biofuel in aviation, shipping and heavy road transport. Maximising energy savings is fundamental. Greenpeace's Energy [R]evolution provides a pathway towards reaching these objectives.
- Biofuel blending targets in the transport sector should be replaced by energy savings and renewable energy targets, with a focus on a shift to electric transport and truly sustainable biofuels produced according to the principles and criteria presented in this paper.

# ENERGY TECHNOLOGIES

FOSSIL FUEL TECHNOLOGIES

NUCLEAR TECHNOLOGIES

RENEWABLE ENERGY  
TECHNOLOGIES

RENEWABLE HEATING AND  
COOLING TECHNOLOGIES



10

“  
technologies which  
convert solar and  
wind into energy  
are likely to gain  
the largest  
market shares”

© NASA EARTH OBSERVATORY IMAGE BY JESSE ALLEN

**IMAGE** LOCATED WELL NORTH OF THE ARCTIC CIRCLE, UUMMANAQ ISLAND IS HOME TO ONE OF THE MOST NORTHERLY TOWNS IN GREENLAND. THE SUN NEVER DROPS BELOW THE HORIZON FOR NEARLY THREE MONTHS IN SUMMER, AND WINTER BRINGS MONTHS OF DARKNESS. SEA ICE STILL SURROUNDED THE ISLAND, BUT BREAKS IN THE ICE—CALLED LEADS—EXPOSE SEAWATER BENEATH IT. USUALLY, SEA ICE AROUND UUMMANAQ BREAKS UP AND DRIFTS AWAY BY THE END OF MAY. HOME TO ABOUT 1,200 PEOPLE, THE TOWN OF UUMMANAQ LIES ON THE SOUTHERN TIP OF THE ISLAND.

This chapter describes the range of technologies available now and in the future to satisfy the world's energy demand. The Energy Revolution scenario is focused on the potential for energy savings and renewable sources, primarily in the electricity and heat generating sectors.

## 10.1 FOSSIL FUEL TECHNOLOGIES

The most commonly used fossil fuels for power generation around the world are coal and gas. Oil is still used where other fuels are not readily available, for example islands or remote sites, or where there is an indigenous resource. Together, coal and gas currently account for 63% of global electricity supply (IEA 2015).<sup>1</sup>

### 10.1.1 COAL COMBUSTION TECHNOLOGIES

In a conventional coal-fired power station, pulverised or powdered coal is blown into a combustion chamber where it is burned at high temperature. The resulting heat is used to convert water flowing through pipes lining the boiler into steam. This drives a steam turbine and generates electricity. Over 90% of global coal-fired capacity uses this system.

Pulverized coal is still the most widely used fuel source and coal power plants, but supercritical conditions have become more common in modern coal plants in order to increase efficiency. Steam-drum boilers are still the norm, however, and they limit total efficiency to roughly 40 percent of the fuel's lower heating value (LHV). At the beginning of the century, state-of-the-art supercritical coal plants, in contrast, reached thermal efficiencies up to 47 percent of LHV (IEA-Coal Online).<sup>2</sup>

Coal power stations can vary in capacity from one block of few hundred megawatts up to ten or more blocks with a total capacity of several thousand megawatts. A number of technologies have been introduced to improve the environmental performance of conventional coal combustion. These include coal cleaning (to reduce the ash content) and various 'bolt-on' or 'end-of-pipe' technologies to reduce emissions of particulates, sulphur dioxide and nitrogen oxide, the main pollutants resulting from coal firing apart from carbon dioxide. Flue gas desulphurisation (FGD), for example, most commonly involves 'scrubbing' the flue gases using alkaline sorbent slurry, which is predominantly lime or limestone based.

More fundamental changes have been made to the way coal is burned both to improve its efficiency and further reduce emissions of pollutants (WCA 2015).<sup>3</sup> These include:

- **Integrated Gasification Combined Cycle:** Coal is not burned directly but reacted with oxygen and steam to form a synthetic gas composed mainly of hydrogen and carbon monoxide. This is cleaned and then burned in a gas turbine to generate electricity and produce steam to drive a steam turbine. IGCC improves the efficiency of coal combustion from 38-40% up to 50%.
- **Supercritical and Ultra supercritical:** These power plants operate at higher temperatures than conventional combustion, again increasing efficiency towards 50%.
- **Fluidised Bed Combustion (FBC):** Coal is burned in a reactor comprised of a bed through which gas is fed to keep the fuel in a turbulent state. This improves combustion, heat transfer and the recovery of waste products. By elevating pressures within a bed, a high-pressure gas stream can be used to drive a gas turbine, generating electricity. Emissions of both sulphur dioxide and nitrogen oxide can be reduced substantially (WCA 2015).
- **Pressurised Pulverised Coal Combustion:** Mainly being developed in Germany, this is based on the combustion of a finely ground cloud of coal particles creating high-pressure, high-temperature steam for power generation. The hot flue gases are used to generate electricity in a similar way to the combined cycle system.

Other potential future technologies involve the increased use of coal gasification. Underground Coal Gasification, for example, involves converting deep underground unworked coal into a combustible gas which can be used for industrial heating, power generation or the manufacture of hydrogen, synthetic natural gas or other chemicals. The gas can be processed to remove CO<sub>2</sub> before it is passed on to end users. Demonstration projects are underway in Australia, Europe, China and Japan.

### 10.1.2 GAS COMBUSTION TECHNOLOGIES

Natural gas can be used for electricity generation through the use of either gas or steam turbines. For the equivalent amount of heat, gas produces about 45% (IEA ETP 2014)<sup>4</sup> less carbon dioxide during its combustion than coal.

Gas turbine plants use the heat from gases to directly operate the turbine. Natural gas fuelled turbines can start rapidly and are therefore often used to supply energy during periods of peak demand, although at higher cost than base load generation power plants.

## REFERENCES

- <sup>1</sup> (IEA 2015) ENERGY CLIMATE AND CHANGE; WORLD ENERGY OUTLOOK SPECIAL REPORT 2015; INTERNATIONAL ENERGY AGENCY, 9 RUE DE LA FÉDÉRATION, 75739 PARIS CEDEX 15, JUNE 2015.
- <sup>2</sup> (IEA-COAL ONLINE 2011) [HTTP://WWW.COALONLINE.ORG/SITE/COALONLINE/CONTENT/VIEWER?LOGDOCID=81996&PHYDOCID=7800&FILENAME=780000023.HTML](http://www.coalonline.org/site/coalonline/content/viewer?LOGDOCID=81996&PHYDOCID=7800&FILENAME=780000023.HTML)
- <sup>3</sup> (WCA 2015) WORLD COAL ASSOCIATION 2015; [HTTP://WWW.WORLDCOAL.ORG/COAL-THE-ENVIRONMENT/COAL-USE-THE-ENVIRONMENT/IMPROVING-EFFICIENCIES/](http://www.worldcoal.org/coal-the-environment/coal-use-the-environment/improving-efficiencies/)
- <sup>4</sup> (IEA-ETP 2014) ENERGY TECHNOLOGY PERSPECTIVE – HARNESSING ELECTRICITIES POTENTIAL; IEA MAY 2014.

Particularly high electric efficiencies can be achieved by combining gas turbines with a steam turbine in combined cycle mode. In a combined cycle gas turbine (CCGT) plant, a gas turbine generator produces electricity and the exhaust gases from the turbine are then used to make steam to generate additional electricity. The efficiency of modern CCGT power stations can be up to 60 (IEA ETP 2014). Most new gas power plants built since the 1990s have been of this type. Historically, a major driver of technology development for gas-fired generation has been the quest for increased efficiency. However, the effort to raise power plant efficiency is not the only technical objective; other criteria, such as part-load efficiency, ramp rate, turndown ratio and start-up times, are important aspects for future flexible power generation systems as well (IEA-ETP 2014). During the transition period to 100% renewable flexible and quick starting gas turbines play an important role to integrate high shares of wind and solar.

In case of low gas prices, CCGT power stations are the cheapest option for electricity generation in many countries. Capital costs have been substantially lower than for coal and nuclear plants and construction time shorter.

## 10.2 CARBON REDUCTION TECHNOLOGIES AND CARBON CAPTURE AND STORAGE (CCS)

Whenever a fossil fuel is burned, carbon dioxide (CO<sub>2</sub>) is produced. Depending on the type of power plant, a large quantity of the gas will dissipate into the atmosphere and contribute to climate change. A hard coal power plant discharges 730 grams of carbon dioxide per kilowatt-hour if it is a (rare) ultra-supercritical coal plant, compared to 810g CO<sub>2</sub>/kWh (IEA-ETP 2014) in an average modern coal plant. A modern gas power plant in comparison emits around about 350g CO<sub>2</sub>/kWh. One method, currently under development, to mitigate the CO<sub>2</sub> impact of fossil fuel combustion is called carbon capture and storage (CCS). It involves capturing CO<sub>2</sub> from power plant smokestacks, compressing the captured gas for transport via pipeline or ship and pumping it into underground geological formations for permanent storage.

While frequently touted as the solution to the carbon problem inherent in fossil fuel combustion, CCS for coal-fired power stations is unlikely to be ready for at least another decade. Despite the 'proof of concept' experiments currently in progress, the technology remains unproven as a fully integrated process in relation to all of its operational components. Suitable and effective capture technology has not been developed and is unlikely to be commercially available any time soon; effective and safe long-term storage on the scale necessary has not been demonstrated; and serious concerns attach to the safety aspects of transport and injection of CO<sub>2</sub> into designated formations, while long term retention cannot reliably be assured.

Deploying the technology in coal power plants is likely to double construction costs, increase fuel consumption by 10-40%, consume more water, generate more pollutants and ultimately require the public sector to ensure that the CO<sub>2</sub> stays where it has been buried. In a similar way to the disposal of nuclear waste, CCS envisages creating a scheme whereby future generations monitor in perpetuity the climate pollution produced by their predecessors.

In October 2014, SaskPower's Boundary Dam unit 3 in Canada became the world's first commercial electricity generating unit with full CO<sub>2</sub> capture. Around 1 million tonnes of CO<sub>2</sub> (MtCO<sub>2</sub>) per year – 90% of CO<sub>2</sub> emissions from the unit – will be captured and stored underground through enhanced oil recovery (EOR) (IEA TCEP 2015).<sup>5</sup> To put this in a global context: 1 million tonnes of CO<sub>2</sub> storage is equal the global energy related CO<sub>2</sub> emissions of about 17 minutes (Teske CCS-1).<sup>6</sup> In 2014, energy-related CO<sub>2</sub> emission added up to 32.3 billion tonnes of CO<sub>2</sub>.

### 10.2.1 CARBON DIOXIDE STORAGE

In order to benefit the climate, captured CO<sub>2</sub> has to be stored somewhere permanently. Current thinking is that it can be pumped under the earth's surface at a depth of over 3,000 feet into geological formations, such as saline aquifers. However, the volume of CO<sub>2</sub> that would need to be captured and stored is enormous - a single coal-fired power plant can produce 7 million tonnes of CO<sub>2</sub> annually.

It is estimated that a single 'stabilisation wedge' of CCS (enough to reduce carbon emissions by 1 billion metric tonnes per year by 2050) would require a flow of CO<sub>2</sub> into the ground equal to the current flow of coal out of the ground - and in addition to the associated infrastructure to compress, transport and pump it underground. It is still not clear that it will be technically feasible to capture and bury this much carbon, both in terms of the number of storage sites and whether they will be located close enough to power plants.

Even if it is feasible to bury hundreds of thousands of megatonnes of CO<sub>2</sub>, there is no way to guarantee that storage locations will be appropriately designed and managed over the timescales required. The world has limited experience of storing CO<sub>2</sub> underground; the longest running storage project at Sleipner in the Norwegian North Sea began operation only in 1996. This is particularly concerning because as long as CO<sub>2</sub> is present in geological sites, there is a risk of leakage. Although leakages are unlikely to occur in well-characterised, managed and monitored sites, permanent storage stability cannot be guaranteed since tectonic activity and natural leakage over long timeframes are impossible to predict.

#### REFERENCES

<sup>5</sup> (IEA TCEP 2015); TRACKING CLEAN ENERGY PROGRESS 2015 - ENERGY TECHNOLOGY PERSPECTIVES 2015, IEA INPUT TO THE CLEAN ENERGY MINISTERIAL, JUNE 2015.

<sup>6</sup> (TESKE - CCS 1) LEAD AUTHORS OWN CALCULATION: 32.3 BN TONNES CO<sub>2</sub> / 8760H = 3.6 BN TONNES /H

Sudden leakage of CO<sub>2</sub> can be fatal. Carbon dioxide is not itself poisonous but is contained (approx. 0.04 %) in the air we breathe. But as concentrations increase, it displaces the vital oxygen in the air; air with concentrations of 7 to 8% CO<sub>2</sub> by volume causes death by suffocation after 30 to 60 minutes (GPI-FH 2008).<sup>7</sup>

There are also health hazards when large amounts of CO<sub>2</sub> are explosively released. Although the gas normally disperses quickly after leaking, it can accumulate in depressions in the landscape or closed buildings, since carbon dioxide is heavier than air. It is equally dangerous when it escapes more slowly and without being noticed in residential areas, for example in cellars below houses.

The dangers from such leaks are known from natural volcanic CO<sub>2</sub> degassing. Gas escaping at the Lake Nyos Crater Lake in Cameroon, Africa, in 1986 killed over 1,700 people. At least ten people have died in the Lazio region of Italy in the last 20 years as a result of CO<sub>2</sub> being released.

### 10.2.2 CARBON STORAGE AND CLIMATE CHANGE TARGETS

Can carbon storage contribute to climate change reduction targets? In order to avoid dangerous climate change, global greenhouse gas emissions need to peak by between 2015 and 2020 and fall dramatically thereafter. However, power plants capable of capturing and storing CO<sub>2</sub> are still being developed and won't become a reality in a truly commercial scale for at least another decade, if ever. This means that even if CCS works, the technology would not make any substantial contribution towards protecting the climate before 2020.

Power plant CO<sub>2</sub> storage will also not be of any great help in attaining the goal of at least an 80% greenhouse gas reduction by 2050 in OECD countries. Even if CCS were to be available in 2020, most of the world's new power plants will have just finished being modernised. All that could then be done would be for existing power plants to be retrofitted and CO<sub>2</sub> captured from the waste gas flow. Retrofitting power plants would be an extremely expensive exercise. 'Capture ready' power plants are equally unlikely to increase the likelihood of retrofitting existing fleets with capture technology.

The conclusion reached in the Energy Revolution scenario is that renewable energy sources are already available, in many cases cheaper, and lack the negative environmental impacts associated with fossil fuel exploitation, transport and processing. It is renewable energy together with energy efficiency and energy conservation – and not carbon capture and storage – that has to increase worldwide so that the primary cause of climate change – the burning of fossil fuels like coal, oil and gas – is stopped.

**Greenpeace opposes any CCS efforts which leads to:**

- public financial support to CCS at the expense of funding renewable energy development and investment in energy efficiency.
- stagnation of renewable energy, energy efficiency and energy conservation improvements.
- inclusion of CCS in the Kyoto Protocol's Clean Development Mechanism (CDM) as it would divert funds away from the stated intention of the mechanism, and cannot be considered clean development under any coherent definition of this term.
- promotion of this possible future technology as the only major solution to climate change, thereby leading to new fossil fuel developments – especially lignite and black coal-fired power plants, and an increase in emissions in the short to medium term.

### 10.3 NUCLEAR TECHNOLOGIES

Generating electricity from nuclear power involves transferring the heat produced by a controlled nuclear fission reaction into a conventional steam turbine generator. The nuclear reaction takes place inside a core and surrounded by a containment vessel of varying design and structure. Heat is removed from the core by a coolant (gas or water) and the reaction controlled by a moderating element or "moderator".

Across the world over the last two decades there has been a general slowdown in building new nuclear power stations because of concern about a possible nuclear accident (following the events at Three Mile Island, Chernobyl, Monju and Fukushima) and increased scrutiny of economics and environmental factors, such as waste management and radioactive discharges.

#### Nuclear reactor designs: evolution and safety issues

By mid-2015 there were 391 nuclear power reactors operating in 31 countries around the world.

Nuclear plants are commonly divided into four generations. There are no clear definitions of design categories (Scheider/Froggatt 2015):<sup>8</sup>

Generation I: Prototype commercial reactors developed in the 1950s and 1960s as modified or enlarged military reactors, originally either for submarine propulsion or plutonium production.

Generation II: Mainstream reactor designs in commercial operation worldwide.

#### REFERENCES

- <sup>7</sup> (GPI-FH 2008) 'FALSE HOPE'; GREENPEACE INTERNATIONAL; EMILY ROCHON ET. AL.; MAY 2008; GREENPEACE INTERNATIONAL; OTTHO HELDRINGSTRAAT 5; 1066 AZ AMSTERDAM; THE NETHERLANDS.
- <sup>8</sup> (SCHEIDER/FROGGATT 2015) THE WORLD NUCLEAR INDUSTRY – STATUS REPORT 2015; PARIS, LONDON, JULY 2015; © A MYCLE SCHNEIDER CONSULTING PROJECT.

Generation III: New generation reactors now being built.

Generation III+ and IV: Reactors developed or significantly modified after the Chernobyl disaster.

Generation III+ reactors include the so-called Advanced Reactors, three of which are already in operation in Japan, with more under construction or planned. About 20 different designs are reported to be under development,<sup>9</sup> most of them 'evolutionary' designs developed from Generation II reactor types with some modifications, but without introducing drastic changes. Some of them represent more innovative approaches.

According to the World Nuclear Association, reactors of Generation III are characterised by the following:

- a standardised design for each type to expedite licensing, reduce capital cost and construction time
- a simpler and more rugged design, making them easier to operate and less vulnerable to operational upsets
- higher availability and longer operating life, typically 60 years
- reduced possibility of core melt accidents
- minimal effect on the environment
- higher burn-up to reduce fuel use and the amount of waste
- burnable absorbers ('poisons') to extend fuel life

To what extent these goals address issues of higher safety standards, as opposed to improved economics, remains unclear.

Of the new reactor types, the European Pressurised Water Reactor (EPR) has been developed from the most recent Generation II designs to start operation in France and Finland (Schneider/Froggatt 2015). Its stated goals are to improve safety levels - in particular to reduce the probability of a severe accident by a factor of ten, achieve mitigation from severe accidents by restricting their consequences to the plant itself, and reduce costs. Compared to its predecessors, however, the EPR displays several modifications which constitute a reduction of safety margins, including:

- The volume of the reactor building has been reduced by simplifying the layout of the emergency core cooling system, and by using the results of new calculations which predict less hydrogen development during an accident.
- The thermal output of the plant has been increased by 15% relative to existing French reactors by increasing core outlet temperature, letting the main coolant pumps run at higher capacity and modifying the steam generators.

- The EPR has fewer redundant pathways in its safety systems than a German Generation II reactor.

Several other modifications are hailed as substantial safety improvements, including a 'core catcher' system to control a meltdown accident. Nonetheless, in spite of the changes being envisaged, there is no guarantee that the safety level of the EPR actually represents a significant improvement. In particular, reduction of the expected core melt probability by a factor of ten is not proven. Furthermore, there are serious doubts as to whether the mitigation and control of a core melt accident with the core catcher concept will actually work.

The World Nuclear Association (WNA) claims that: "Newer advanced reactors [Generation III+] now being built have simpler designs which reduce capital cost. They are more fuel efficient and are inherently safer. In more detail, it lists some of the design characteristics of which the most relevant to this analysis are (Schneider/Froggatt 2015):

- a standardized design for each type to expedite licensing, reduce capital cost and reduce construction time,
- a simpler and more rugged design, making them easier to operate and less vulnerable to operational upsets,
- further reduced possibility of core melt accidents,
- substantial grace period, so that following shutdown the plant requires no active intervention for (typically) 72 hours,
- resistance to serious damage that would release radioactivity after an aircraft impact.

Price rises occur throughout the period from project announcement to operation. For example, in 2003, the French Industry Ministry estimated that construction costs for an EPR would be just over €1 billion (US\$1.2 billion) per reactor. The price tag had tripled by the time the contract was signed for the Flamanville plant in 2007, and by 2012, the estimated cost had reached €8.5 billion (US\$10.6 billion) (Schneider/Froggatt 2015).

Finally, Generation IV reactors are currently being developed with the aim of commercialisation in 20-30 years.

## 10.4 RENEWABLE POWER TECHNOLOGIES AND HEATING TECHNOLOGIES

Renewable energy covers a range of natural sources which are constantly renewed and therefore, unlike fossil fuels and uranium, will never be exhausted. Most of them derive from the effect of the sun and moon on the earth's weather patterns. They also produce none of the harmful emissions and pollution associated with 'conventional' fuels. Although hydroelectric power has been used on an industrial scale since the middle of the last century, the serious exploitation of other renewable sources has a more recent history.

### REFERENCES

9 (IAEA 2004; WNO 2004)

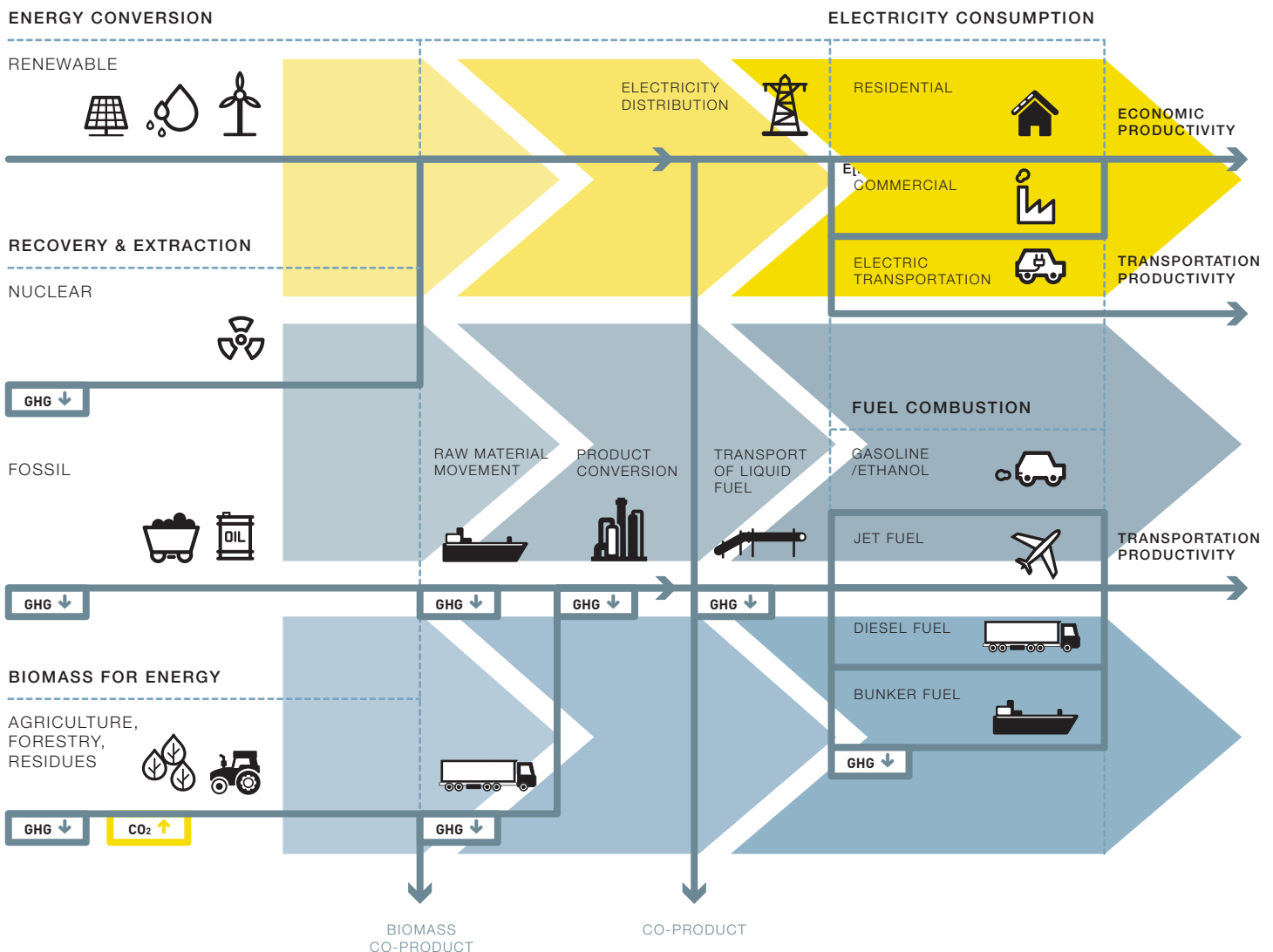
**BOX 10.1 | DEFINITION OF RENEWABLE ENERGY**

“Renewable energy is any form of energy from solar, geophysical or biological sources that is replenished by natural processes at a rate that equals or exceeds its rate of use. RE is obtained from the continuing or repetitive flows of energy occurring in the natural environment and includes resources such as biomass, solar energy, geothermal heat, hydropower, tide and waves and ocean thermal energy, and wind energy. However, it is possible to utilize biomass at a greater rate than it can grow, or to draw heat from a

geothermal field at a faster rate than heat flows can replenish it. On the other hand, the rate of utilization of direct solar energy has no bearing on the rate at which it reaches the Earth. Fossil fuels (coal, oil, natural gas) do not fall under this definition, as they are not replenished within a time frame that is short relative to their rate of utilization.”

*IPCC definition for renewable energy (Source IPCC, Special Report Renewable Energy /SRREN Renewables for Power Generation.*

**FIGURE 10.1 | ILLUSTRATIVE SYSTEM FOR ENERGY PRODUCTION AND USE ILLUSTRATING THE ROLE OF RE ALONG WITH OTHER PRODUCTION OPTIONS**



### 10.4.1 SOLAR POWER (PHOTOVOLTAICS)

There is more than enough solar radiation available all over the world to satisfy a vastly increased demand for solar power systems. The sunlight which reaches the earth's surface is enough to provide 7,900 times as much energy as we can currently use. On a global average, each square metre of land is exposed to enough sunlight to produce 1,700 kWh of power every year. The average irradiation in Europe is about 1,000 kWh per square metre and 1,800 kWh in the Middle East.

Photovoltaic (PV) technology involves the generation of electricity from light. Photovoltaic systems contain cells that convert sunlight into electricity. Inside each cell there are layers of a semi-conducting material. Light falling on the cell creates an electric field across the layers, causing electricity to flow. The intensity of the light determines the amount of electrical power each cell generates. A photovoltaic system does not need bright sunlight in order to operate. It can also generate some electricity on cloudy and rainy days from diffuse sunlight.

The most important parts of a PV system are the cells which form the basic building blocks, the modules which bring together large numbers of cells into a unit, and, in some situations, the inverters used to convert the electricity generated into a form suitable for everyday use. When a PV installation is described as having a capacity of 3 kWp (peak), this refers to the output of the system under standard testing

conditions, allowing comparison between different modules. In central Europe a 3 kWp rated solar electricity system, with a surface area of approximately 27 square metres, would produce enough power to meet the electricity demand of an energy conscious household.

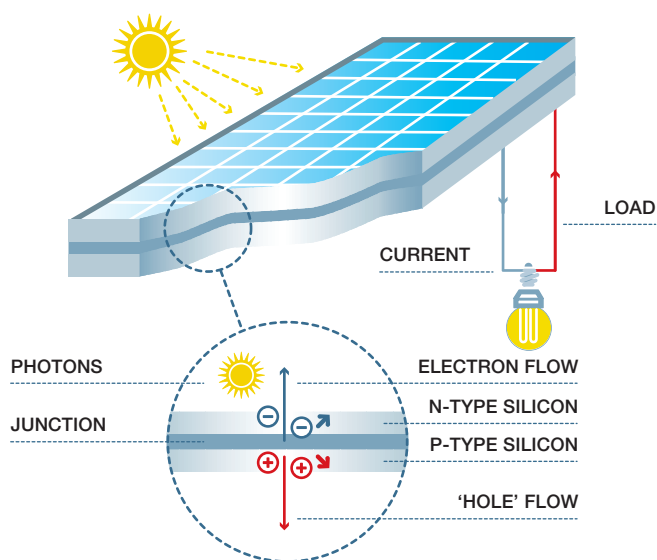
There are several different PV technologies and types of installed system.

PV systems can provide clean power for small or large applications. They are already installed and generating energy around the world on individual homes, housing developments, offices and public buildings.

Today, fully functioning solar PV installations operate in both built environments and remote areas where it is difficult to connect to the grid or where there is no energy infrastructure. PV installations that operate in isolated locations are known as stand-alone systems. In built areas, PV systems can be mounted on top of roofs (known as Building Adapted PV systems – or BAPV) or can be integrated into the roof or building facade (known as Building Integrated PV systems – or BIPV).

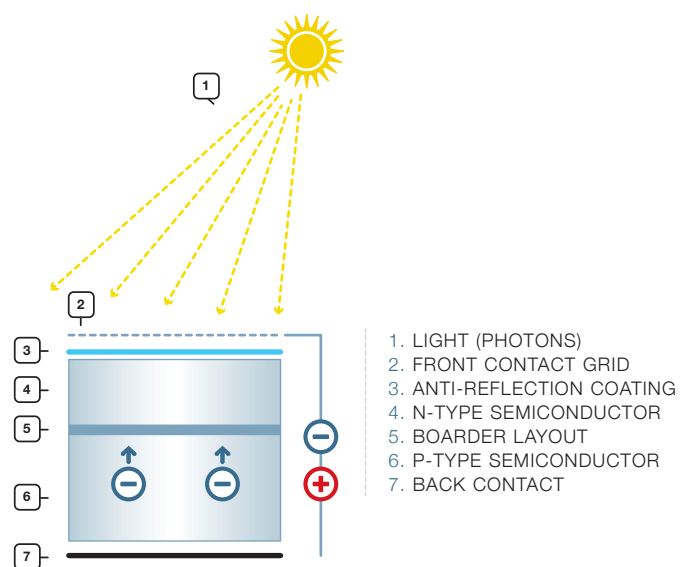
Modern PV systems are not restricted to square and flat panel arrays. They can be curved, flexible and shaped to the building's design. Innovative architects and engineers are constantly finding new ways to integrate PV into their designs, creating buildings that are dynamic, beautiful and provide free, clean energy throughout their life.

FIGURE 10.2 | EXAMPLE OF THE PHOTOVOLTAIC EFFECT



source EPIA.

FIGURE 10.3 | PHOTOVOLTAIC TECHNOLOGY



source EPIA.



### 10.4.2 PV CELLS AND MODULES

**Crystalline silicon technology:** Crystalline silicon cells are made from thin slices cut from a single crystal of silicon (mono crystalline) or from a block of silicon crystals (polycrystalline or multi crystalline). This technology is the most common, representing about 80% of the market today. In addition, it also exists in the form of ribbon sheets (Hoffmann /Teske 2012).<sup>10</sup>

**Thin film technology:** Thin film modules are constructed by depositing extremely thin layers of photosensitive materials onto a substrate such as glass, stainless steel or flexible plastic. The latter opens up a range of applications, especially for building integration (roof tiles) and end-consumer purposes. Four types of thin film modules are commercially available at the moment: Amorphous Silicon, Cadmium Telluride, Copper Indium/Gallium Diselenide/Disulphide and multi-junction cells.

**Other emerging cell technologies (at the development or early commercial stage):** These include Concentrated Photovoltaic, consisting of cells built into concentrating collectors that use a lens to focus the concentrated sunlight onto the cells, and Organic Solar Cells, whereby the active material consists at least partially of organic dye, small, volatile organic molecules or polymer.

Cells are connected to form larger units called modules. Thin sheets of EVA (Ethyl Vinyl Acetate) or PVB (Polyvinyl Butyral) are used to bind cells together and provide weather protection. The modules are normally enclosed between a transparent cover (usually glass) and a weatherproof backing sheet (typically made from a thin polymer). Modules can be framed for extra mechanical strength and durability. Thin film modules are usually encapsulated between two sheets of glass, so a frame is not needed (EPIA-2011).<sup>11</sup>

**TABLE 10.1 | TYPICAL TYPE AND SIZE OF APPLICATIONS PER MARKET SEGMENT**

TYPE OF APPLICATION	RESIDENTIAL < 10 kWp	COMMERCIAL 10 kWp - 100 kWp	INDUSTRIAL 100 kWp - 1 MWp	UTILITY-SCALE > 1 MWp
GROUND-MOUNTED	-	-	YES	YES
ROOF-TOP	YES	YES	YES	
INTEGRATED TO FACADE/ROOF	YES	YES	-	

source ?

#### REFERENCES

<sup>10</sup> (HOFFMANN/TESKE 2012) PREPARATION FOR EPIA/GREENPEACE SOLARGENERATION REPORT SERIES(EDITION I – VI).  
<sup>11</sup> (EPIA 2011) SOLARGENERATION 6 – EPIA-GREENPEACE REPORT; EUROPEAN PHOTOVOLTAIC INDUSTRY ASSOCIATION (EPIA); GPI, BRUSSELS / AMSTERDAM; 2011.

### 10.4.3 PV SYSTEMS

The key parts of a solar energy generation system are:

- Photovoltaic modules to collect sunlight
- An inverter to transform direct current (DC) to alternate current (AC)
- A set of batteries for stand-alone PV systems
- Support structures to orient the PV modules toward the Sun.

The system components, excluding the PV modules, are referred to as the balance of system (BOS) components.

#### Industrial and utility-scale power plants

Large industrial PV systems can produce enormous quantities of electricity at a single location. Such power plants have outputs ranging from hundreds of kilowatts (kW) to hundreds of megawatts (MW).

The solar panels for industrial systems are usually mounted on frames on the ground. However, they can also be installed on large industrial buildings, such as warehouses, airport terminals and railways stations. The system can make double use of an urban space and put electricity into the grid where energy-intensive consumers are located.

#### Residential and commercial systems

##### GRID CONNECTED

Grid connected arrays are the most popular type of solar PV systems for homes and businesses in the developed world. Connected to the local grid, they allow any excess power produced to be sold to the utility. When solar energy is not available, electricity can be drawn from the grid. An inverter is used to convert the DC power produced by the system to AC power for running normal electrical equipment. This type of PV system is referred to as being 'on-grid.' A 'Grid Support' system can be connected to the local grid along with a back-up battery. Any excess solar electricity produced after the battery has been charged is then sold to the grid. This system is ideal for use in areas of unreliable power supply.

##### STAND-ALONE, OFF-GRID SYSTEMS

Off-grid PV systems have no connection to a grid. An off-grid system usually has batteries, so power can still be used at night or after several days of low sun. An inverter is needed to convert the DC power generated into AC power for use in appliances. Typical off-grid applications include:

- **Off-grid systems for rural electrification** Grid Typical off-grid installations bring electricity to remote areas or villages in developing countries. They can be small home systems, which cover a household's basic electricity needs, or larger solar mini-grids, which provide enough power for several homes, a community or small business use.

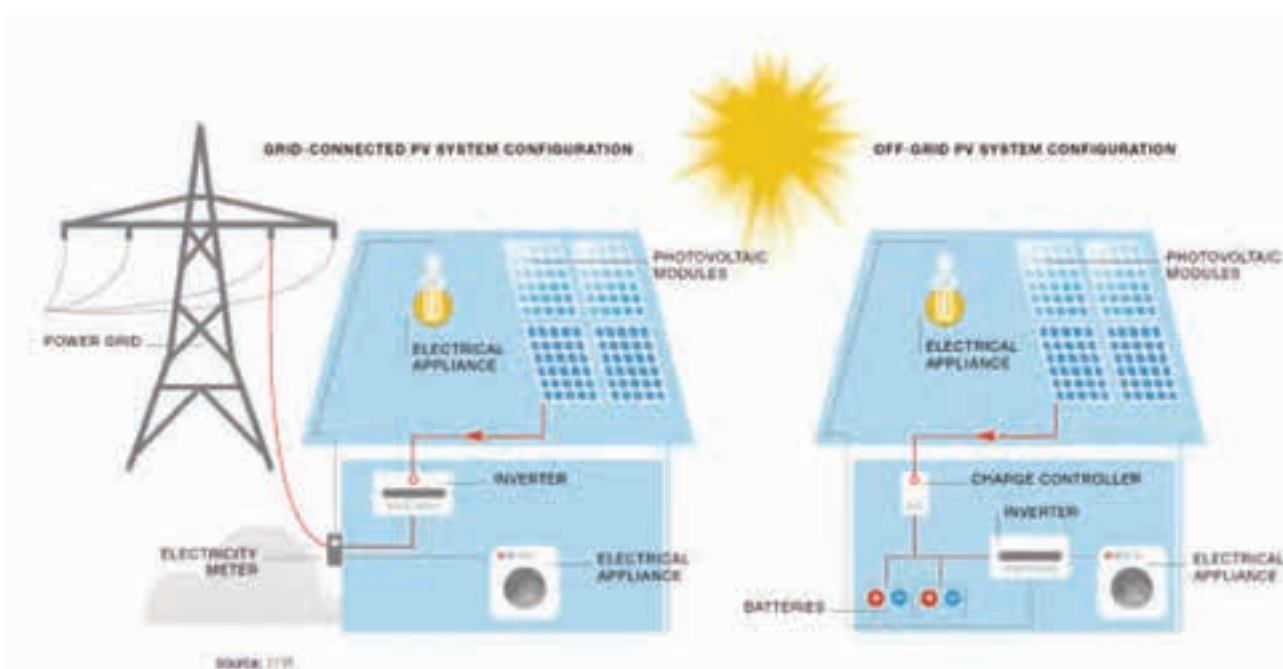
- **Off-grid industrial applications** Off-grid industrial systems are used in remote areas to power repeater stations for mobile telephones (enabling communications), traffic signals, marine navigational aids, remote lighting, highway signs and water treatment plants. Both full PV and hybrid systems are used. Hybrid systems are powered by the sun when it is available and by other fuel sources during the night and extended cloudy periods. Off-grid industrial systems provide a cost-effective way to bring power to areas very far from existing grids. The high cost of installing cabling makes off-grid solar power an economical choice.
- **Consumer goods** PV cells are now found in many everyday electrical appliances such as watches, calculators, toys, and battery chargers (as for instance embedded in clothes and bags). Services such as water sprinklers, road signs, lighting and telephone boxes also often rely on individual PV systems.
- **Hybrid Systems** A solar power system can be combined with another source of power – such as a biomass generator, a wind turbine or diesel generator - to ensure a consistent supply of electricity. A hybrid system can be grid-connected, standalone or grid-supported.

#### 10.4.4 CONCENTRATING SOLAR POWER (CSP)

The majority of the world's electricity today—whether generated by coal, gas, nuclear, oil or biomass—comes from creating a hot fluid. Concentrating Solar Power (CSP) technologies produce electricity by concentrating direct-beam solar irradiance to heat a liquid, solid or gas that is then used in a downstream process for electricity generation. CSP simply provides an alternative heat source. CSP uses direct sunlight, called 'beam radiation' or Direct Normal Irradiation (DNI) – sunlight not dispersed by clouds, fumes or dust in the atmosphere. This sunlight reaches the Earth's surface in parallel beams for concentration. Suitable sites need to get a lot of this direct sun - at least 2,000 kilowatt-hours (kWh) per square metre annually and the best sites receive more than 2,800 kWh/m<sup>2</sup>/year. In these regions, one square kilometre of land is enough to generate as much as 100-130 gigawatt hours (GWh) of solar electricity per year using solar thermal technology.

Thus, CSP plants, also called solar thermal power plants, produce electricity in much the same way as conventional power stations. They obtain their energy input by concentrating solar radiation and converting it to high temperature steam or gas to drive a turbine or motor engine. Large mirrors concentrate sunlight into a single line or point.

FIGURE 10.4 | DIFFERENT CONFIGURATIONS OF SOLAR POWER SYSTEMS



source EPIA 2011

The heat created there is used to generate steam. This hot, highly pressurised steam is used to power turbines which generate electricity. In sun-drenched regions, CSP plants can guarantee a large proportion of electricity production. This technology builds on much of the current know-how on power generation in the world today. It will benefit from on-going advances in solar concentrator technology and as improvements continue to be made in steam and gas turbine cycles.

Some of the advantages of CSP:

- it can integrate thermal storage for peaking loads (less than one hour) and intermediate loads (three to six hours);
- it can provide industrial process heat
- it can be used of desalination to produce drinking water
- it has modular and scalable components;

#### Types of CSP Systems

All systems require four main elements: a concentrator, a receiver, some form of transfer medium or storage, and power conversion. Many different types of system are possible, including combinations with other renewable and non-renewable technologies, but there are four main groups of solar thermal technologies. This whole subchapter is based on a technical paper of the European Solar Thermal Electricity Association (ESTELA 2015):<sup>12</sup>

#### Parabolic trough

Parabolic trough plants use rows of parabolic trough collectors, each of which reflect the solar radiation into an absorber tube. The troughs track the Sun around one axis, with the axis typically being oriented north-south. Synthetic oil circulates through the tubes, heating up to approximately 400°C. The hot oil from numerous rows of troughs is passed through a heat exchanger to generate steam for a conventional steam turbine generator to generate electricity. Some of the plants under construction have been designed to produce power not only during sunny hours but also to store energy, allowing the plant to produce an additional 7.5 hours of nominal power after sunset, which dramatically improves their integration into the grid. Molten salts are normally used as storage fluid in a hot-and-cold two-tank concept. Plants in operation in Europe: Andasol 1 and 2 (50 MW +7.5 hour storage each); Puertollano (50 MW); Alvarado (50 MW) and Extresol 1 (50 MW + 7.5 hour storage). Land requirements are of the order of 2 km<sup>2</sup> for a 100-MWe plant, depending on the collector technology and assuming no storage is provided.

#### Linear Fresnel Systems

Collectors resemble parabolic troughs, with a similar power generation technology, using long lines of flat or nearly flat Fresnel reflectors to form a field of horizontally mounted flat mirror strips, collectively or individually tracking the sun. These are cheaper to install than trough systems but not as efficient. There is one plant currently in operation in Europe: Puerto Errado (2 MW).

#### Central receiver or solar tower

Central receivers (or “power towers”) are point-focus collectors that are able to generate much higher temperatures than troughs and linear Fresnel reflectors. This technology uses a circular array of mirrors (heliostats) where each mirror tracks the Sun, reflecting the light onto a fixed receiver on top of a tower. Temperatures of more than 1,000°C can be reached. A heat-transfer medium absorbs the highly concentrated radiation reflected by the heliostats and converts it into thermal energy to be used for the subsequent generation of superheated steam for turbine operation. To date, the heat transfer media demonstrated include water/steam, molten salts, liquid sodium and air. If pressurised gas or air is used at very high temperatures of about 1,000°C or more as the heat transfer medium, it can even be used to directly replace natural gas in a gas turbine, thus making use of the excellent efficiency (60%+) of modern gas and steam combined cycles.

After an intermediate scaling up to 30 MW capacity, solar tower developers now feel confident that grid-connected tower power plants can be built up to a capacity of 200 MWe solar-only units. Use of heat storage will increase their flexibility. Although solar tower plants are considered to be further from commercialisation than parabolic trough systems, they have good longer-term prospects for high conversion efficiencies. Projects are being developed in Spain, South Africa and Australia.

#### Parabolic dish

A dish-shaped reflector is used to concentrate sunlight on to a receiver located at its focal point. The receiver moves with the dish. The concentrated beam radiation is absorbed into the receiver to heat a fluid or gas to approximately 750°C. This is then used to generate electricity in a small piston, Stirling engine or micro turbine attached to the receiver. Dishes have been used to power Stirling engines up to 900°C, and also for steam generation. The largest solar dishes have a 485-m<sup>2</sup> aperture and are in research facilities or demonstration plants. Currently the capacity of each Stirling engine is small — in the order of 10 to 25 kWelectric. There is now significant operational experience with dish/Stirling engine systems and the technology has been under development for many years, with advances in dish structures, high-temperature receivers, use of hydrogen as the circulating working fluid, as well as some experiments

#### REFERENCES

<sup>12</sup> (ESTELA 2015) CONCENTRATED SOLAR POWER OUTLOOK 2015; EUROPEAN SOLAR THERMAL ELECTRIC ASSOCIATION; BRUSSELS SEPTEMBER 2015.

with liquid metals and improvements in Stirling engines — all bringing the technology closer to commercial deployment. Although the individual unit size may only be of the order of tens of kWe, power stations having a large capacity of up to 800 MWe have been proposed by aggregating many modules. Because each dish represents a stand-alone electricity generator, from the perspective of distributed generation there is great flexibility in the capacity and rate at which units are installed. However, the dish technology is less likely to integrate thermal storage. The potential of parabolic dishes lies primarily for decentralised power supply and remote, stand-alone power systems. Projects are currently planned in the United States, Australia and Europe.

#### CSP system components

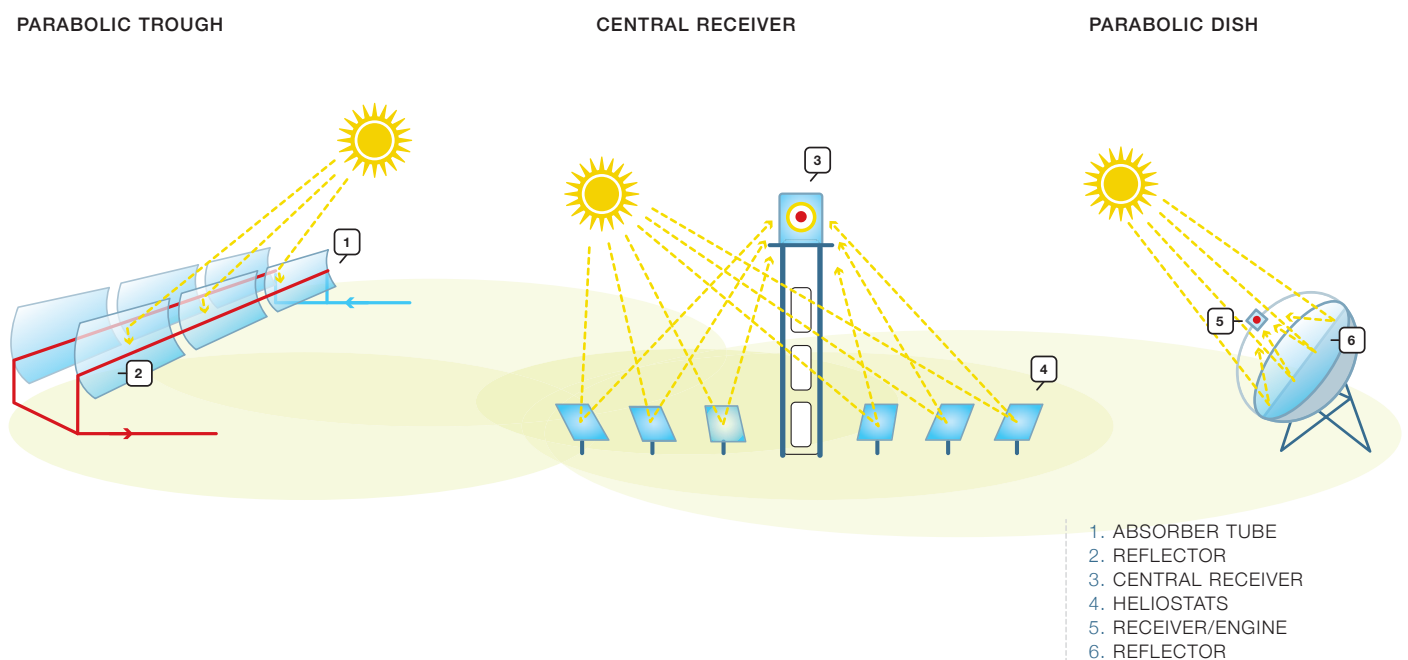
In addition to the different types of solar reflector systems, a CSP power plant has power generation equipment like what is used in gas power plants; increasingly, a thermal storage unit is also installed. The output of a CSP power plant is power and different levels of heat which can be used for industrial process heat, for the desalination of water, etc.

#### 10.4.5 CSP - THERMAL STORAGE

Thermal energy storage integrated into a system is an important attribute of CSP. Until recently, this has been primarily for operational purposes, providing 30 minutes to 1 hour of full-load storage. This eases the impact of thermal transients such as clouds on the plant, assists start-up and shut-down, and provides benefits to the grid. Trough plants are now designed for 6 to 7.5 hours of storage, which is enough to allow operation well into the evening when peak demand can occur and tariffs are high.

To provide solar electricity after sunset with CSP, thermal energy is stored in very large quantities. Thermal energy storage (TES) systems are an integral part of a CSP power plant, allowing eliminating short term variations of electricity production: the thermal energy collected by the solar field is stored for conversion to electricity later in the day. Storage can adapt the profile of power produced throughout the day to demand and can increase the total power output of a plant with given maximum turbine capacity by storing excess energy of a larger solar field before it is used in the turbine. Eventually the plant can be operated nearly at 100% capacity factor as a base load plant in appropriate locations.

FIGURE 10.5 | CSP TECHNOLOGIES: PARABOLIC TROUGH, CENTRAL RECEIVER/SOLAR TOWER AND PARABOLIC DISH



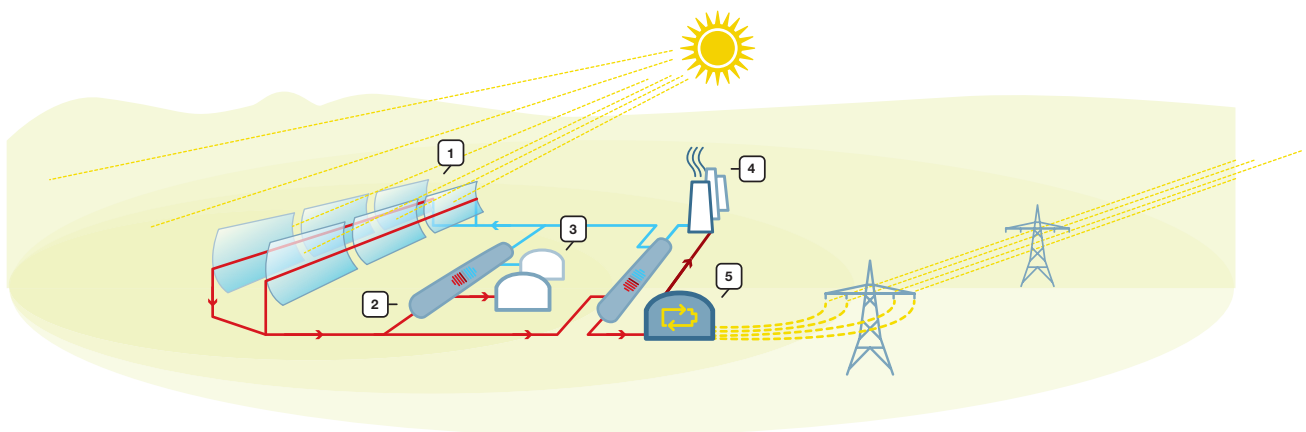
Thermal storage has been used in 40% of Spanish plants since 2010 and is almost included in every new plant today. A number of 5 to 10 hours storage, depending on the DNI is an average. The IEA reports that “when thermal storage is used to increase the capacity factor, it can reduce the levelised cost of solar thermal electricity (LCOE). Thermal storage also has remarkable “return” efficiency, especially when the storage medium is also used as heat transfer fluid. It may then achieve 98% return efficiency – i.e., energy losses are limited to about 2%.

There are 3 categories of storage media that can be used in CSP plant but their maturity degree is different (ESTELA 2015):

- **Advanced sensible heat storage systems:** Such systems are in most of the state-of-the-art CSP plants, with a “two-tank molten salt storage” (two tanks with molten salts at different temperature levels). The development of new storage mediums with improved thermal stability, such as molten salt mixtures will allow higher temperatures to be attained. Higher temperatures allow for increased energy density within the TES and hence lower the specific investment costs for the system. Improvements to TES systems would have the potential to reduce CAPEX while improving efficiency.

- **Cost-effective latent heat storage systems:** Latent heat storage has not been implemented in commercial STE plants yet, but several research projects support the introduction and use of phase changing materials in TES technologies. The use of latent heat storage offers new possibilities for DSG helping in achieving cost competitiveness with sensible heat technologies.
- **Thermochemical storage systems:** To date, there are no known commercial systems for thermochemical TES in STE plants. Research into the application of this technology started 40 years ago. Development projects assume potentials in energy density up to 10 times higher than a comparable sensible heat TES (ESTELA 2015).

FIGURE 10.6 | PRINCIPLE OF CSP SYSTEMS



1. **PARABOLIC MIRRORS (CONCENTRATING SOLAR COLLECTOR FIELD).** HEAT TRANSFER FLUID IS HEATED DIRECTLY BY THE SUN'S RAYS.

2. **HEAT EXCHANGERS.**

3. **THERMAL STORAGE TANKS.**

4. **CONDENSER.** CONVERTS THE STEAM BACK INTO WATER AND THE PROCESS BEGINS AGAIN.

5. **STEAM TURBINE & GENERATOR.** INSIDE THE STEAM EXPANDS AND SPINS THE TURBINE, GENERATING ELECTRICITY THAT PASSES THROUGH A TRANSFORMER BEFORE BEING FEED INTO THE GRID.

source ESTELA 2015.

#### 10.4.6 WIND POWER

Wind energy has grown faster than all other electricity sources in the last 20 years, and turbine technology has advanced sufficiently that a single machine can have a capacity of 7 Megawatt. In Europe, wind farms are generally well integrated into the environment and accepted by the public. Smaller models can produce electricity for areas that are not connected to a central grid, through use of battery storage.

Wind speeds and patterns are good enough for this technology on all continents, on both coastlines and inland. The wind resource out at sea is particularly productive and is now being harnessed by offshore wind parks with foundations embedded in the ocean floor.

##### Wind turbine design

Modern wind technology is available for low and high wind speeds, and in a variety of climates. A variety of onshore wind turbine configurations have been investigated, including both horizontal and vertical axis designs (see Figure 4 ). The horizontal axis design dominates, and most designs now centre on the three-blade, upwind rotor; locating the turbine blades upwind of the tower prevents the tower from blocking wind flow onto the blades and producing extra aerodynamic noise and loading (EWEA 2008).<sup>13</sup>

The blades are attached to a hub and main shaft, which transfers power to a generator, sometimes via a gearbox (depending on design). The electricity output is channelled down the tower to a transformer and eventually into the local grid. The

main shaft and main bearings, gearbox, generator and control system are contained within a housing called the nacelle.

As turbine size has increased over time, turbine output is controlled by pitching (i.e., rotating) the blades along their long axis.<sup>14</sup> Reduced cost of power electronics allowed for variable speed wind turbine operation, which helps maintain production in variable and gusty winds, keeps large wind power plants generating during electrical faults, and provides reactive power.

Modern wind turbines typically operate at variable speeds using full-span blade pitch control. Over the past 30 years, the average wind turbine size has grown significantly (Figure 9), with most onshore wind turbines installed globally in 2014 having a rated capacity of 3.5 to 7.5 MW; the average size of turbines installed in 2014 was at around 2.5 – 3.0 MW.

As of 2015, wind turbines used on land typically have 80 to 120-m tall towers, with rotors between 80 to 125 m in diameter. The average tower installed in 2014 in Germany for example was 93 m tall (STATISTICA 2015).<sup>15</sup> Some commercial machines have diameters and tower heights above 125 m, and even larger models are being developed. Modern turbines operate spin at 12 to 20 revolutions per minute (RPM), much slower than the models from the 1980s models, which spun at 60 RPM. Modern rotors are slower, less visually disruptive and less noisy.

Onshore wind turbines are typically grouped together into wind power plants, with between 5- 300 MW generating capacity, and are sometimes also called wind farms. Turbines have been getting larger to help reduce the cost of generation (reach better quality wind), reduce investment per unit of capacity and reduce operation and maintenance costs (EWEA 2014).<sup>16</sup>

FIGURE 10.7 | EWEA EARLY WIND TURBINE DESIGNS

##### HORIZONTAL AXIS TURBINES

##### VERTICAL AXIS TURBINES



source South et.al. 1983 / EWEA 2008.

##### REFERENCES

- 13 (EWEA 2009) WIND ENERGY – THE FACTS; EUROPEAN WIND ENERGY ASSOCIATION; BRUSSELS/BELGIUM ; [HTTP://WWW.WIND-ENERGY-THE-FACTS.ORG](http://www.wind-energy-the-facts.org).
- 14 EWEA 2009.
- 15 (STATISTICA 2015); ONLINE STATISTICAL RESEARCH TOOL; [HTTP://WWW.STATISTA.COM/STATISTICS/263905/EVOLUTION-OF-THE-HUB-HEIGHT-OF-GERMAN-WIND-TURBINES/](http://www.statista.com/statistics/263905/evolution-of-the-hub-height-of-german-wind-turbines/).
- 16 (EWEA 2014) WIND ENERGY SCENARIOS FOR 2020; EUROPEAN WIND ENERGY ASSOCIATION; JULY 2014; [WWW.EWEA.ORG](http://www.ewea.org).

For turbines in land, there will be engineering and logistical constraints to size because the components have to travel by road.

Modern wind turbines have nearly reached their theoretical maximum (0.59) of aerodynamic efficiency, measured by the coefficient of performance (0.44 in the 1980s to about 0.50 by the mid-2000s).

### Offshore wind energy technology

By the end of 2014, the existing offshore market made up just 2.4% of the world's land-based installed wind capacity; however, the potential at sea is driving the latest developments towards large turbine sizes. Wind technology currently develops for two different markets: offshore and sites of high wind resources; and onshore sites of moderate resources which requires different technical concepts.

The first offshore wind power plant was built in 1991 in Denmark, consisting of eleven 450 kW wind turbines. In 2014 1,713 MW of new offshore capacity was added, bringing the total to 8,759 megawatts (GWEC 2015).<sup>17</sup>

By going offshore, wind energy can make use stronger winds and provide clean energy to countries where there is less technical potential for land-based wind energy development and where it would conflict with other land uses. There is less 'shear' near hub height with offshore wind. Greater economies of scale result from large turbines that can be transported by ship and from larger power plants. Offshore wind farms also reduce the

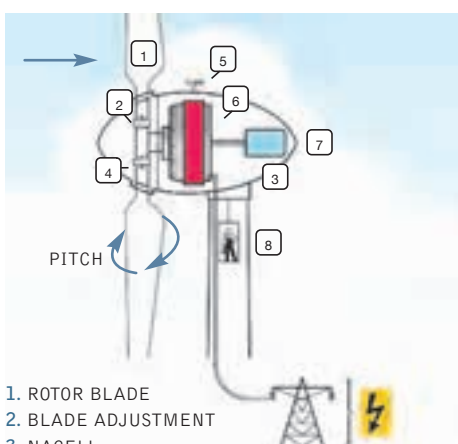
need for new, long-distance, land-based transmission infrastructure that wind farms on land can require.<sup>18</sup>

There is considerable interest in offshore wind energy technology in the EU and, increasingly, in other regions such as China, Japan and North America, despite the typically higher costs relative to onshore wind energy, because of its advantage to supply large coastal cities and/or industry.

Offshore wind turbines built between 2009 and 2014 typically have nameplate capacity ratings of 2 to 5 MW, and larger turbines are under development. Offshore wind farms are installed in groups of 50 to 100 turbines with total capacities in the low to medium hundred megawatt capacity, and often installed in water between 10 and 20 m deep. Distance to shore has is mostly less than 20 km, but average distance has increased over time.<sup>19</sup> Offshore wind is likely to be installed at greater depths, and the larger turbines (5 to 10MW or larger) as experience is gained and for greater economies of scale.

Offshore wind turbine technology has been very similar to onshore designs, with some structural modifications and with special foundations.<sup>20</sup> Other design features include marine navigational equipment and monitoring and infrastructure to minimise expensive servicing. By 2015, the offshore wind industry started moving into the commercialization phase; further cost reductions are likely. The German Offshore Wind Industry expects that, in stable market conditions, the costs of offshore wind power can decrease by up to 39 % by 2023 (GOWEF 2014).<sup>21</sup>

**FIGURE 10.8 | BASIC COMPONENT OF WIND TURBINES WITHOUT GEARBOXES**



1. ROTOR BLADE
2. BLADE ADJUSTMENT
3. NACELL
4. ROTOR SHAFT
5. ANEMOMETOR
6. GENERATOR
7. SYSTEM CONTROL
8. LIFT INSIDE THE TOWER

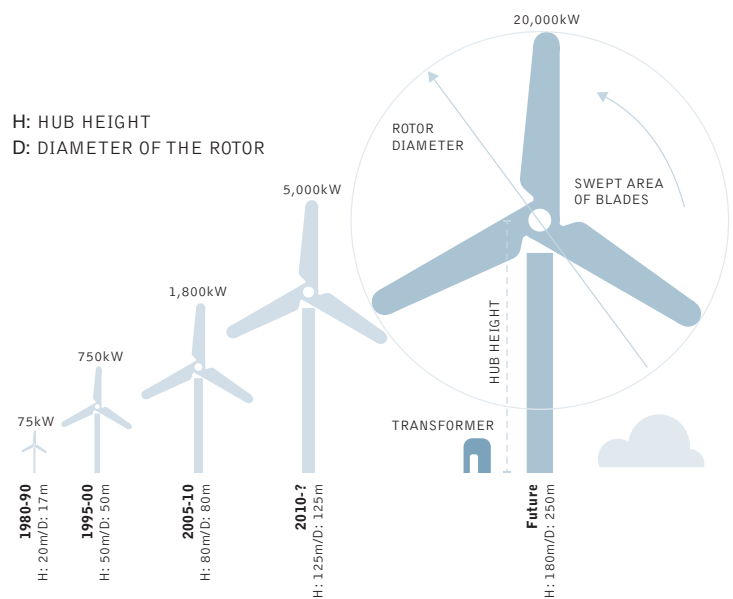
source EWEA 2008.

### REFERENCES

17 (GWEC, 2015) GLOBAL WIND REPORT 2014 – ANNUAL MARKET UPDATE; GLOBAL WIND ENERGY COUNCIL, BRUSSELS/BELGIUM, WWW.GWEC.NET ; MARCH 2015.

18 CARBON TRUST, 2008B; SNYDER AND KAISER, 2009B; TWIDELL AND GAUDIOSI, 2009.

**FIGURE 10.9 | GROWTH OF SIZE OF TYPICAL COMMERCIAL WIND TURBINES**



source EWEA 2008/2014.

19 (EWEA, 2010A).

20 MUSIAL, 2007; CARBON TRUST, 2008B.

21 (GOWEF 2014); COST REDUCTION POTENTIALS OF OFFSHORE WIND POWER IN GERMANY; PROGNOSE / FICHTNER, COMMISSIONED BY: THE GERMAN OFFSHORE WIND ENERGY FOUNDATION; ANDREAS WAGNER; OLDENBURGER STR. 65; 26316 VAREL; GERMANY; WWW.OFFSHORESTIFTUNG.DE

### The next step – Floating Offshore Wind

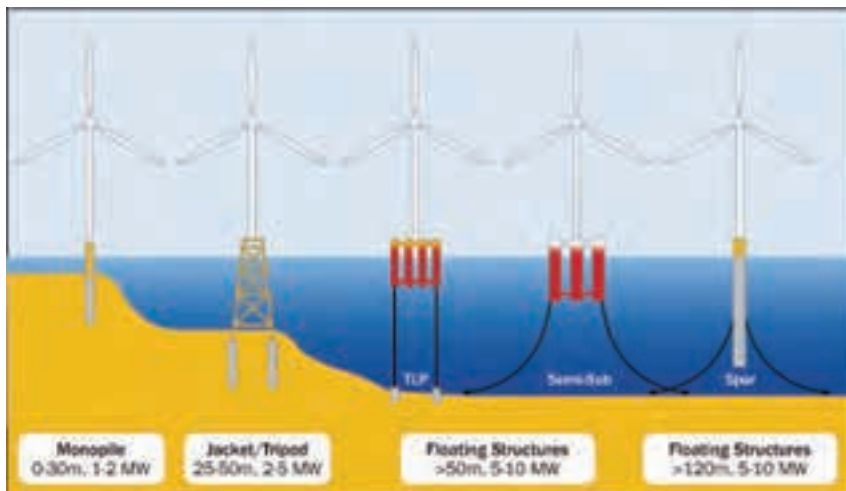
In order to unlock the full potential of offshore wind, areas with water depth greater than 50 meters must be opened for this technique. Large cities in Asia and Latin America are often close to the sea, and offshore wind farms can potentially supply mega-cities with electricity and/or the production of syn-fuels in the future.

The concept of a floating wind turbine has existed since the early 1970s, but the industry only started researching it in the mid-1990s. In 2008, Blue H technologies installed the first test floating wind turbine off the Italian coast. The turbine had a rated capacity of 80 kW; after a year of testing and data collection, it was decommissioned. A year later, the Poseidon 37 project followed, a 37m-wide wave energy plant and floating wind turbine foundation tested at DONG's offshore wind farm at Onsevig. In 2009, Statoil installed the world's first large scale grid connected floating wind turbine, Hywind, in Norway, with a 2.3 MW Siemens turbine. The second large scale floating system, WindFloat, developed by Principle Power in partnership with EDP and Repsol, was installed off the Portuguese coast in 2011. Equipped with a 2 MW Vestas wind turbine, the installation started producing energy in 2012 (EWEA 7-2013).<sup>22</sup>

2011 was the best year on record for deep offshore development with two floating substructures tested, SeaTwirl and SWAY, in addition to the grid connected Windfloat project. By the end of 2013, offshore wind farms used three main types of deep offshore foundations, adapted from the offshore oil and gas industry (EWEA 7-2013):

- Spar Buoy: a very large cylindrical buoy stabilizes the wind turbine using ballast. The centre of gravity is much lower in the water than the centre of buoyancy. Whereas the lower parts of the structure are heavy, the upper parts are usually empty elements near the surface, raising the centre of buoyancy. The Hywind concept consists of this slender, ballast-stabilised cylinder structure.
- Tension Leg Platform: a very buoyant structure is semi submerged. Tensioned mooring lines are attached to it and anchored on the seabed to add buoyancy and stability.
- Semi-submersible: combining the main principles of the two previous designs, a semi submerged structure is added to reach the necessary stability. WindFloat uses this technology.

FIGURE 10.10 | OFFSHORE WIND FOUNDATION TECHNOLOGIES



source EWEA-7-2013.

#### REFERENCES

<sup>22</sup> (EWEA-7-2013); DEEP WATER - THE NEXT STEP FOR OFFSHORE WIND ENERGY; EUROPEAN WIND ENERGY ASSOCIATION - JULY 2013; ISBN: 978-2-930670-04-1.



### 10.4.7 BIOMASS ENERGY

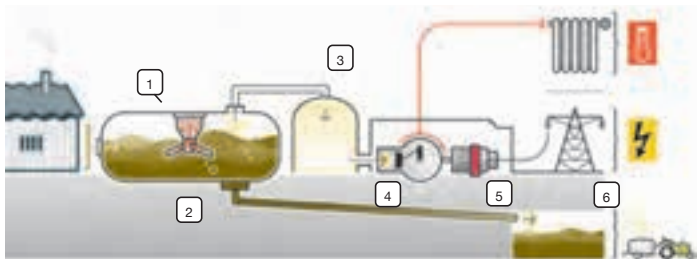
Biomass is a broad term used to describe material of recent biological origin that can be used as a source of energy. It includes wood, crops, algae and other plants as well as agricultural and forest residues. Biomass can be used for a variety of end uses: heating, electricity generation or as fuel for transportation. The term 'bioenergy' is used for biomass energy systems that produce heat and/or electricity; 'biofuels', for liquid fuels used in transport. Biodiesel and bioethanol manufactured from various crops have become increasingly common as vehicle fuels, especially as the cost of oil has risen.

Biological power sources are renewable, easily stored, and, if sustainably harvested, CO<sub>2</sub> neutral. The gas emitted during their transfer into useful energy is balanced by the carbon dioxide absorbed when they were growing plants.

#### Bioenergy for power generation

Electricity generating biomass power plants work just like natural gas or coal power stations, except that the fuel must be processed before it can be burned. These power plants are generally not as large as coal power stations because their fuel supply needs to grow as near as possible to the plant. Heat generation from biomass power plants can result either from utilising a Combined Heat and Power (CHP) system, piping the heat to nearby homes or industry, or through dedicated heating systems. Small heating systems using specially produced pellets made from waste wood, for example, can be used to heat single family homes instead of natural gas or oil.

FIGURE 10.11 | BIOGAS TECHNOLOGY



1. HEATED MIXER
2. CONTAINMENT FOR FERMENTATION
3. BIOGAS STORAGE
4. COMBUSTION ENGINE
5. GENERATOR
6. WASTE CONTAINMENT

### 10.4.8 BIOMASS TECHNOLOGY

A number of processes can be used to convert energy from biomass: thermochemical processes (direct combustion of solids, liquids or a gas via pyrolysis or gasification) and biological systems, (decomposition of solid biomass to liquid or gaseous fuels by processes such as anaerobic digestion and fermentation).

#### Thermochemical processes

##### DIRECT COMBUSTION

Direct biomass combustion is the most common way of converting biomass into energy for both heat and electricity, accounting for over 90% of biomass generation. Combustion processes are well understood; in essence, when carbon and hydrogen in the fuel react with excess oxygen to form CO<sub>2</sub> and water and release heat. In rural areas, many forms of biomass are burned for cooking. Wood and charcoal are also used as a fuel in industry. A wide range of existing commercial technologies are tailored to the characteristics of the biomass and the scale of their applications (IEA Bio-2009).

The technologies types are fixed bed, fluidised bed or entrained flow combustion. In fixed bed combustion, such as a grate furnace, air first passes through a fixed bed for drying, gasification and charcoal combustion. The combustible gases produced are burned after the addition of secondary air, usually in a zone separated from the fuel bed. In fluidised bed combustion, the primary combustion air is injected from the bottom of the furnace with such high velocity that the material inside the furnace becomes a seething mass of particles and bubbles. Entrained flow combustion is suitable for fuels available as small particles, such as sawdust or fine shavings, which are pneumatically injected into the furnace.

##### GASIFICATION

Biomass fuels are increasingly being used with advanced conversion technologies, such as gasification systems, which are more efficient than conventional power generation. Biomass gasification occurs when a partial oxidation of biomass happens upon heating, producing a combustible gas mixture (called producer gas or fuel gas) rich in CO and hydrogen (H<sub>2</sub>) that has an energy content of 5 to 20 MJ/Nm<sup>3</sup> (depending on the type of biomass and whether gasification is conducted with air, oxygen or through indirect heating). This energy content is roughly 10 to 45% of the heating value of natural gas (IPCC SRREN 2011).<sup>23</sup>

#### REFERENCES

- <sup>23</sup> (IPCC-AR5-SPM) INTERNATIONAL PANEL ON CLIMATE CHANGE – 5TH ASSESSMENT REPORT; CLIMATE CHANGE 2014, SUMMARY FOR POLICY MAKERS; [HTTP://IPCC.CH/PDF/ASSESSMENT-REPORT/AR5/SYR/AR5\\_SYR\\_FINAL\\_SPM.PDF](http://ipcc.ch/pdf/assessment-report/ar5/syr/ar5_syr_final_spm.pdf)

Fuel gas can then be upgraded to a higher-quality gas mixture called biomass synthesis gas or syngas (Faaij 2006).<sup>24</sup> A gas turbine, boiler or steam turbine can be used to employ unconverted gas for electricity co-production. Coupled with electricity generators, syngas can be used as a fuel in place of diesel in suitably designed or adapted internal combustion engines. Most commonly available gasifiers use wood or woody biomass, specially designed gasifiers can convert non-woody biomass materials (Yokoyama and Matsumura 2008).<sup>25</sup> Compared to combustion, gasification is more efficient, providing better controlled heating, higher efficiencies in power production and the possibility for co-producing chemicals and fuels (Kirkels and Verbong 2011).<sup>26</sup> Gasification can also decrease emission levels compared to power production with direct combustion and a steam cycle.

#### PYROLYSIS

Pyrolysis is the thermal decomposition of biomass occurring in the absence of oxygen (anaerobic environment) that produces a solid (charcoal), a liquid (pyrolysis oil or bio-oil) and a gas product. The relative amounts of the three co-products depend on the operating temperature and the residence time used in the process. Lower temperatures produce more solid and liquid products and higher temperatures more biogas. Heating the biomass feedstock to moderate temperatures (450°C to 550°C) produce oxygenated oils as the major products (70 to 80%), with the remainder split between a bio char and gases (IEA Bio-2009).

#### Biological systems

These processes are suitable for very wet biomass materials such as food or agricultural wastes, including farm animal slurry.

#### ANAEROBIC DIGESTION

Anaerobic digestion means the breakdown of organic waste by bacteria in an oxygen-free environment. This produces a biogas typically made up of 65% methane and 35% carbon dioxide. Purified biogas can then be used both for heating and electricity generation.

#### FERMENTATION

Fermentation is the process by which growing plants with a high sugar and starch content are broken down with the help of micro-organisms to produce ethanol and methanol. The end product is a combustible fuel that can be used in vehicles.

Biomass power station capacities typically range up to 15 MW, but larger plants are possible. However bio mass power station should use the heat as well, in order to use the energy of the biomass as much as possible, and therefore the size should not be much larger than 25 MW (electric). This size could be supplied by local bioenergy and avoid unsustainable long-distance fuel supply.

#### REFERENCES

- <sup>24</sup> (FAAIJ 2006).  
<sup>25</sup> (YOKOYAMA AND MATSUMURA 2008).  
<sup>26</sup> (KIRKELS AND VERBONG 2011).

BIOFUELS

Converting crops into ethanol and bio diesel made from rapeseed methyl ester (RME) currently takes place mainly in Brazil, the USA and Europe. Also processes to produce synthetic fuels from ‘biogenic synthesis’ gases will play a larger role in the future, especially for aviation and marine transport systems. Theoretically, biofuels can be produced from any biological carbon source, although the most common are photosynthetic plants. Various plants and plant-derived materials are used for biofuel production.

Globally, biofuels are most commonly used to power vehicles but can also be used for other purposes. The production and use of biofuels must result in a net reduction in carbon emissions compared to the use of traditional fossil fuels to have a positive effect in climate change mitigation. Sustainable biofuels can reduce the dependency on petroleum and thereby enhance energy security.

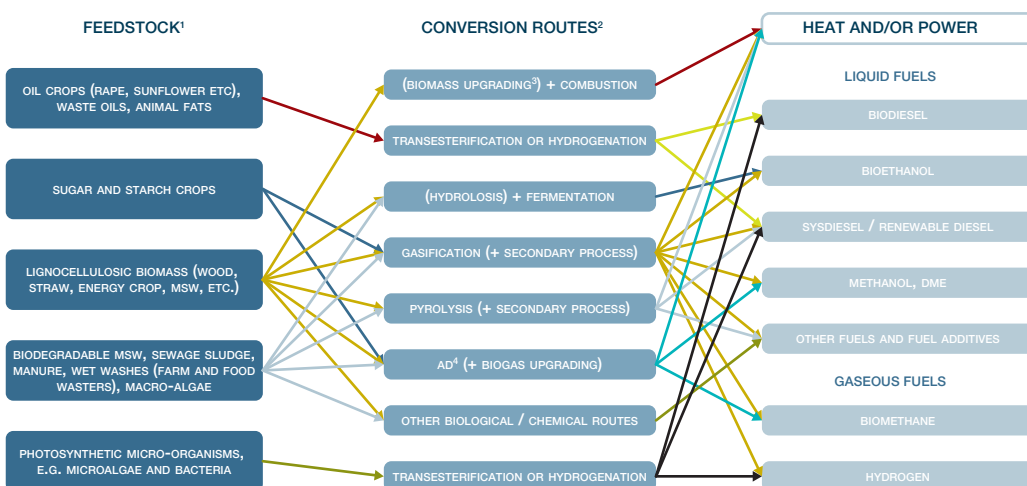
- Bioethanol is a fuel manufactured through the fermentation of sugars. Sugars are used directly (sugar cane or beet) or by breaking down starch in grains such as wheat, rye, barley or maize. In the European Union, bioethanol is mainly produced from grains, with wheat as the dominant feedstock. In Brazil, the preferred feedstock is sugar cane, whereas in the USA it is corn (maize). Bioethanol produced from cereals has a by-product, a protein-rich animal feed called Dried Distillers Grains with Soluble (DDGS). For every tonne of cereals used for ethanol production, on average one third will enter the

animal feed stream as DDGS. Because of its high protein level, DDGS is currently used as a replacement for soy cake. Bioethanol can either be blended into gasoline (petrol) directly or be used in the form of ETBE (Ethyl Tertiary Butyl Ether).

- Biodiesel is a fuel produced from vegetable oil sourced from rapeseed, sunflower seeds or soybeans along with used cooking oils or animal fats. If used vegetable oils are recycled as feedstock for biodiesel production, pollution from discarded oil is reduced, providing a new way of transforming a waste product into transport energy. Blends of biodiesel and conventional diesel are the most common products distributed in the retail transport fuel market.
- Most countries use a labelling system to explain the proportion of biodiesel in any fuel mix. Fuel containing 20% biodiesel is labelled B20, while pure biodiesel is referred to as B100. Blends of 20 % biodiesel with 80 % petroleum diesel (B20) can generally be used in unmodified diesel engines. Used in its pure form, B100 may require certain engine modifications. Biodiesel can also be used as a heating fuel in domestic and commercial boilers. Older furnaces may contain rubber parts that would suffer from biodiesel’s solvent properties but can otherwise burn it without any conversion.

There are many different biomass feedstock types and numerous conversion technologies to produce fuels for heat and/or power and transport technologies; Figure 10.12 provides a simplified overview.

FIGURE 10.12 | SCHEMATIC VIEW OF COMMERCIAL BIOENERGY ROUTES<sup>27</sup>



1 Parts of each feedstock, e.g. crop residues, could also be used in other routes.  
 2 Each route also gives co-products.  
 3 Biomass upgrading includes any one of the densification processes (pelletisation, pyrolysis, torrefaction, etc.)  
 4 AD = Anaerobic Digestion  
 source IEA-BIO 2009

REFERENCES

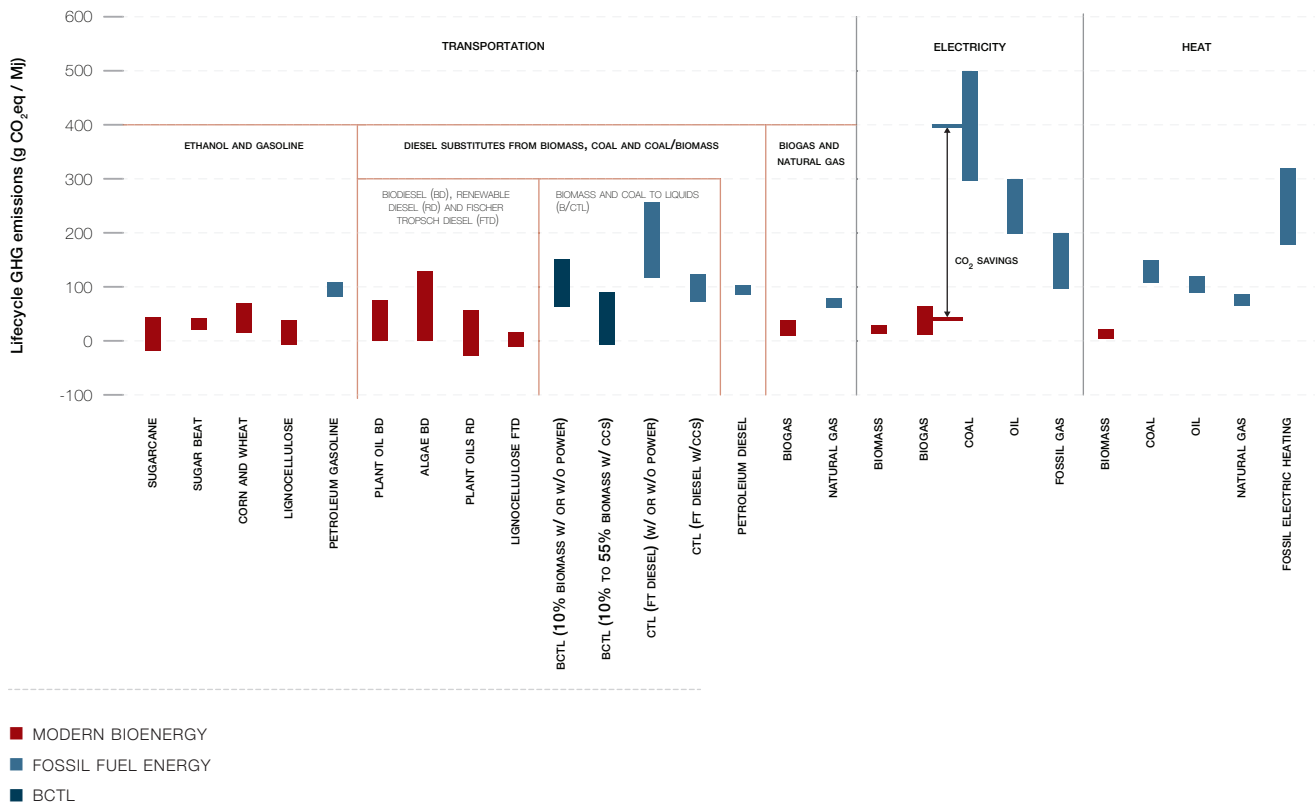
27 (IEA BIO-2009) BIOENERGY – A SUSTAINABLE AND RELIABLE ENERGY SOURCE MAIN REPORT; INTERNATIONAL ENERGY AGENCY 2009.

### 10.4.9 BIOENERGY AND GREENHOUSE GAS (GHG) EMISSION REDUCTION

It is of great importance that bioenergy lower greenhouse gas emissions; only then does the use of bioenergy make ecologic sense. The ranges of GHG emissions per unit of energy output (MJ) from major modern bioenergy chains compared to conventional and selected advanced fossil fuel energy systems (land use-related net changes in carbon stocks and land management impacts are excluded) are shown in Figure 10.13. Commercial and developing (such as algae biofuels, Fischer-Tropsch, etc.) systems for biomass and fossil technologies are illustrated.

Greenpeace has a very strict policy in order to use only sustainable bioenergy in future energy systems. Guidelines for the future use of bioenergy are documented in Chapter 8.

FIGURE 10.13 | GHG EMISSIONS OF BIOENERGY AND FOSSIL FUELS



note ccs = Carbon Capture and Storage  
source IPCC-SRREN 2012

#### 10.4.10 GEOTHERMAL ENERGY

Geothermal energy is heat derived from underneath the earth's crust. In most areas, this heat comes from a long way down and has mostly dissipated by the time it reaches the surface, but in some places the geothermal resources are relatively close to the surface and can be used as non-polluting sources of energy. These "hotspots" include the western part of the USA, west and central Eastern Europe, Iceland, Asia and New Zealand (the Pacific Rim).

The uses of geothermal energy depend on temperatures. Low and moderate areas temperature areas (less than 90°C or between 90°C and 150°C, respectively) can be used for their heat directly, while the highest temperature resources (above 150°C) are suitable only for electric power generation. Today's total global geothermal generation is approximately 10,700 MW, with nearly one-third in USA (over 3,000 MW), and the next biggest share in Philippines (1,900 MW) and Indonesia (1,200 MW) (IPCC-SRREN 2012).<sup>28</sup>

##### Technology and applications

Geothermal energy is currently extracted using wells or other means that produce hot fluids from either hydrothermal reservoirs with naturally high permeability or reservoirs engineered and fractured to extract heat. See below for more information on these "enhanced geothermal systems". Production wells discharge hot water and/or steam.

In high-temperature hydrothermal reservoirs, water occurs naturally underground under pressure in liquid form. As it is extracted, the pressure drops, and the water is converted to steam to a turbine that generates electricity. Any remaining hot water may go through the process again to obtain more steam. The remaining salty water is sent back to the reservoir through injection wells, sometimes via another system to use the remaining heat. A few reservoirs, such as The Geysers in the USA, Larderello in Italy, Matsukawa in Japan, and some Indonesian fields, naturally produce steam vapour that can be used in a turbine. Hot water produced from intermediate-temperature hydrothermal or Enhanced Geothermal System (EGS) reservoirs can also be used in heat exchangers to generate power in a binary cycle, or in direct use applications. Recovered fluids are also injected back into the reservoir.<sup>29</sup> The key technologies are:

**Exploration and drilling** includes estimating where the resource is, its size and depth with geophysical methods and then drilling exploration wells to test the resource. Today, geothermal wells are drilled over a range of depths down to 5 km using methods similar to those used for oil and gas. Advances in exploration and drilling can technology can be expected. For example, if several wells are drilled from the same pad, it can access more heat resources and minimize the surface impact.<sup>30</sup>

**Reservoir engineering** is focused on determining the volume of geothermal resource and the optimal plant size. The optimum has to consider sustainable use of the resources and safe, efficient operation. The modern method of estimating reserves and sizing power plants is 'reservoir simulation' – a process that starts with a conceptual model followed by a calibrated, numerical representation.<sup>31</sup> Then, future behaviour is forecast under selected load conditions using an algorithm (such as TOUGH2) to select the plant size. Injection management looks after the production zones, and uses data to make sure the hot reservoir rock is re-charged sufficiently.

**Geothermal power plants** use the steam created from heating water via natural underground sources to power a turbine that produces electricity. The technique has been used for decades in the US, New Zealand and Iceland and is under trial in Germany, where it is necessary to drill many kilometres down to reach high-temperature zones. The basic types of geothermal power plants in use today are steam-condensing turbines, binary-cycle units and cogeneration plants.

- Steam condensing turbines can be used in flash or dry-steam plants operating at sites with intermediate and high-temperature resources ( $\geq 150^{\circ}\text{C}$ ). The power units usually have 20 to 110 MWe (DiPippo, 2008) and may utilize a multiple-flash system, obtaining steam at successively lower pressures to get as much energy as possible from the geothermal fluid. The only difference between a flash plant and a dry-steam plant is that the latter does not require brine separation, resulting in a simpler and cheaper design.
- Binary-cycle plants, typically organic Rankine cycle (ORC) units, typically extract heat from low and intermediate-temperature geothermal fluids from hydrothermal and EGS reservoirs. Binary plants are more complex than condensing ones since the geothermal fluid (water, steam or both) passes through a heat exchanger to heat another working fluid (such as isopentane or isobutene), which vaporises, drives a turbine, and then is air-cooled or condensed with water. Binary plants are often constructed as smaller, linked modular units (a few MWe each).
- Combined or hybrid plants comprise two or more of the above basic types to improve versatility, increase overall thermal efficiency, improve load-following capability, and efficiently cover a wide resource-temperature range.
- Cogeneration plants or combined / cascaded heat and power plants (CHP) produce both electricity and hot water for direct use. They can be used in relatively small industries and communities of a few thousand people. Iceland, for example, runs geothermal cogeneration plants with a combined capacity of 580 MWth.<sup>32</sup> At the Oregon Institute of Technology, a CHP plant cover most of the electricity and all the heat demand.<sup>33</sup>

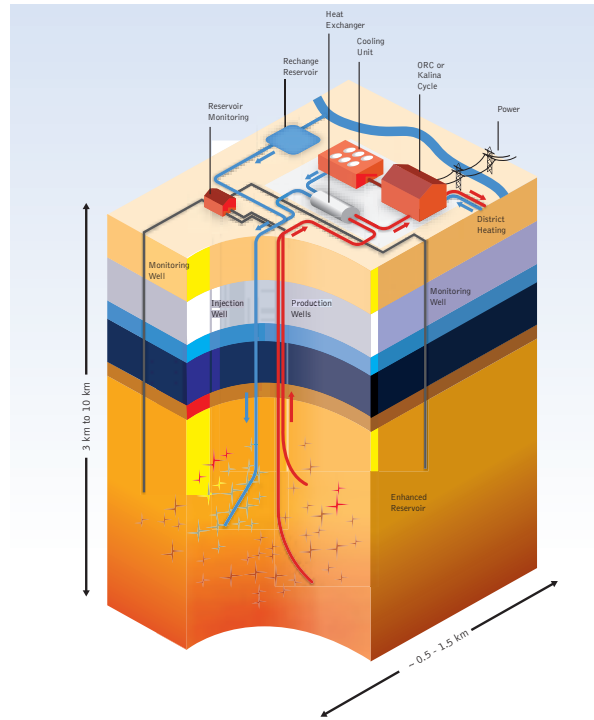
##### REFERENCES

- 28 (IPCC-SRREN 2012); CHAPTER 4 GEOTHERMAL ENERGY.  
 29 ARMSTEAD AND TESTER, 1987; DICKSON AND FANELLI, 2003; DIPIPPO, 2008.  
 30 IPCC, SRREN 2012.  
 31 GRANT ET AL., 1982.  
 32 HJARTARSON AND EINARSSON, 2010.  
 33 LUND AND BOYD, 2009.

#### 10.4.11 ENHANCED GEOTHERMAL SYSTEMS (EGS)

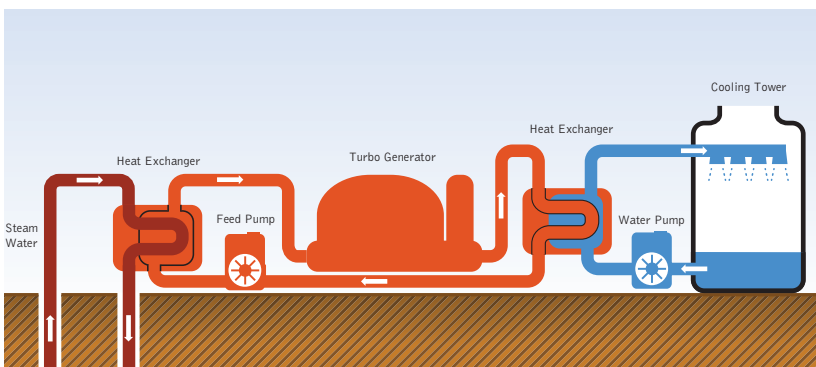
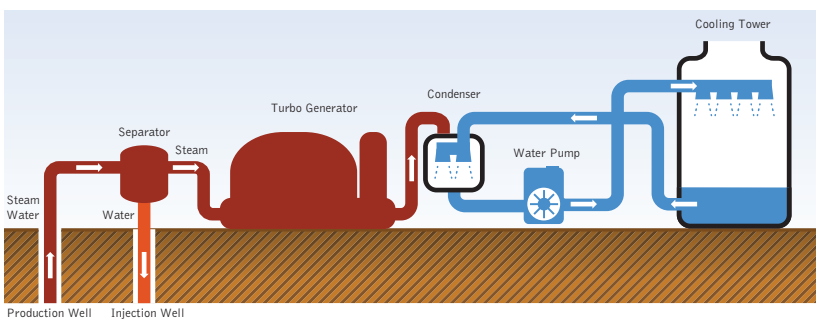
In some areas, the subsurface regions are 'stimulated' to make use of geothermal energy for power generation. A reservoir is made by creating or enhancing a network of fractures in the rock underground so fluid can move between the injection point and where power is produced (production wells) (see Figure 10.14). Heat is extracted by circulating water through the reservoir in a closed loop; it can be used for power generation or heating via the technologies described above. Recently developed models provide insights into geothermal exploration and production. EGS projects are currently at a demonstration and experimental stage in a number of countries. The key challenges are creating enough reservoirs with sufficient volumes for commercial rates of energy production, while protecting water resources and avoiding instability of the earth or seismicity (earthquakes).<sup>34</sup>

**FIGURE 10.14 | SCHEME SHOWING AN ENHANCED GEOTHERMAL SYSTEM (EGS)**



source IPCC 2012: Special Report on Renewable Energy Sources and Climate Change Mitigation. Prepared by Working Group III of the Intergovernmental Panel on Climate Change, Cambridge University Press.

**FIGURE 10.15 | SCHEMATIC DIAGRAM OF A GEOTHERMAL CONDENSING STEAM POWER PLANT (TOP) AND A BINARY-CYCLE POWER PLANT (BOTTOM)**



source IPCC 2012: Special Report on Renewable Energy Sources and Climate Change Mitigation. Prepared by Working Group III of the Intergovernmental Panel on Climate Change, Cambridge University Press.

#### REFERENCES

34 TESTER ET AL., 2006.

#### 10.4.12 HYDROPOWER

Water has been used to produce electricity for about a century. Even today, it covers around one fifth of the world's power demand. The main requirement for hydropower is to create an artificial head of water that has sufficient energy to power a turbine when diverted into a channel or pipe.

##### Classification by head and size

The 'head' in hydropower refers to the difference between the upstream and the downstream water levels, which determines the water pressure on the turbines. Along with discharge, the pressure level determines what type of hydraulic turbine is used. The classification of 'high head' and 'low head' varies from country to country, and there is no generally accepted scale.

Broadly, Pelton impulse turbines are used for high heads (where a jet of water hits a turbine and reverses direction). Francis reaction turbines are used to exploit medium heads (which run full of water and in effect generate hydrodynamic 'lift' to propel the turbine blades). For low heads, Kaplan and Bulb turbines are applied.

Classification according to capacity refers to installed capacity measured in MW. Small-scale hydropower plants are more likely to be run-of-river facilities than are larger hydropower plants, but reservoir (storage) hydropower stations of all sizes use the same basic components and technologies. It typically takes less time and effort to construct and integrate small hydropower schemes into local environments<sup>35</sup> so their deployment is increasing in many parts of the world. Small schemes are often considered in remote areas where other energy sources are not viable or are not economically attractive.

**Greenpeace supports the sustainability criteria developed by the International Rivers Network ([www.internationalrivers.org](http://www.internationalrivers.org)).**

#### REFERENCES

<sup>35</sup> EGRE AND MILEWSKI, 2002.

##### Classification by facility type

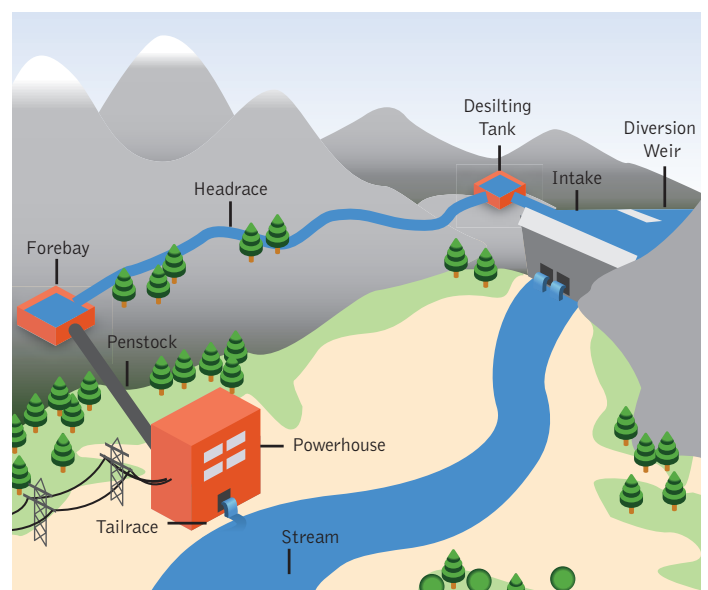
Hydropower plants are also classified in the following categories according to operation and type of flow:

- run-of-river (RoR)
- storage (reservoir)
- pumped storage, and
- in-stream technology, a young and less-developed technology.

##### RUN-OF-RIVER

These plants draw the energy for electricity mainly from the available flow of the river and do not collect significant amounts of stored water. They may include some short-term storage (hourly, daily), but the generation profile will generally be dictated by local river flow conditions. Because generation depends on rainfall, it may have substantial daily, monthly or seasonal variations, especially when located in small rivers or streams with widely varying flows. In a typical plant, a portion of the river water might be diverted to a channel or pipeline (penstock) to convey the water to a hydraulic turbine connected to an electricity generator (see Figure 10.16). RoR projects may form cascades along a river valley, often with a reservoir-type hydropower plants in the upper reaches of the valley. Run-of-river installation is relatively inexpensive. Facilities typically have lower environmental impacts than similar-sized storage hydropower plants.

**FIGURE 10.16 | RUN-OF-RIVER HYDROPOWER PLANT**



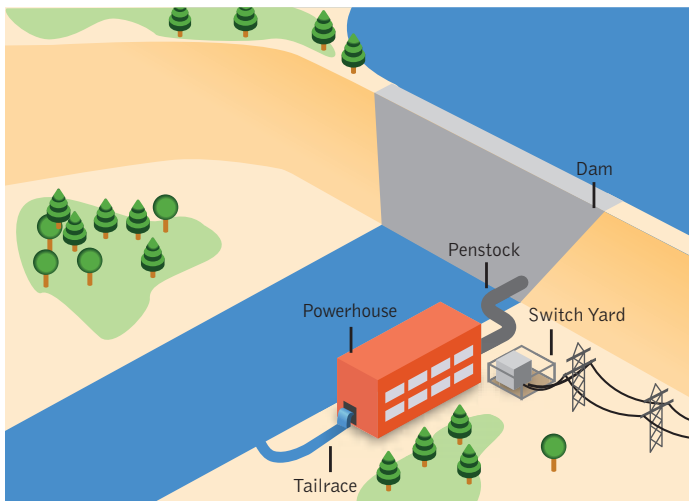
source IPCC 2012: Special Report on Renewable Energy Sources and Climate Change Mitigation. Prepared by Working Group III of the Intergovernmental Panel on Climate Change, Cambridge University Press.

STORAGE HYDROPOWER

Hydropower projects with a reservoir are also called storage hydropower. The reservoir reduces dependence on the variability of inflow, and the generating stations are located at the dam toe or further downstream, connected to the reservoir through tunnels or pipelines (Figure 10.17). Reservoirs are designed according to the landscape. In many parts of the world, river valleys are inundated to make an artificial lake. In geographies with mountain plateaus, high-altitude lakes are another kind of reservoir that retains many of the properties of the original lake. In these settings, the generating station is often connected to the reservoir lake via tunnels (lake tapping). For example, in Scandinavia, natural high-altitude lakes create high pressure systems where the heads may reach over 1,000 m. A storage power plant may have tunnels coming from several reservoirs and may also be connected to neighbouring watersheds or rivers. Large hydroelectric power plants with concrete dams and extensive collecting lakes often have very negative effects on the environment, requiring the flooding of habitable areas.

10.

FIGURE 10.17 | TYPICAL HYDROPOWER PLANT WITH RESERVOIR

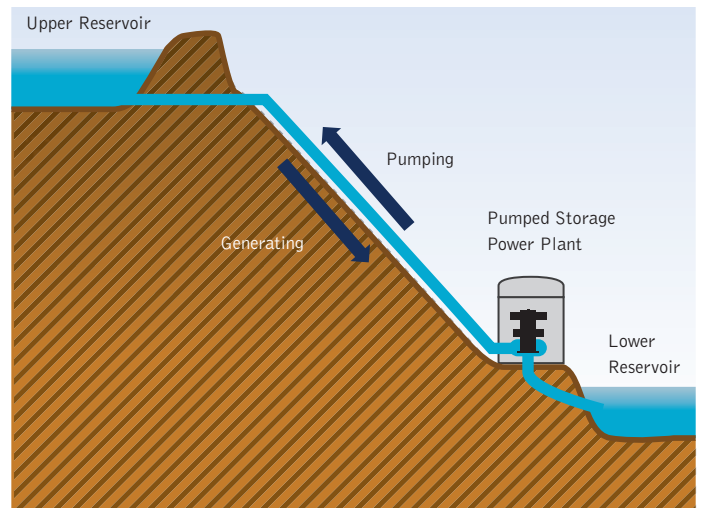


source IPCC 2012: Special Report on Renewable Energy Sources and Climate Change Mitigation. Prepared by Working Group III of the Intergovernmental Panel on Climate Change, Cambridge University Press.

PUMPED STORAGE

Pumped storage plants generate electricity but are energy storage devices. In such a system, water is pumped from a lower reservoir into an upper reservoir (Figure 10.18), usually during off-peak hours when electricity is cheap. The flow is reversed to generate electricity during the daily peak load period or at other times of need. The plant is a net energy consumer overall, because it uses power to pump water; however, the plant provides system benefits by helping to meet fluctuating demand profiles. Pumped storage is the largest-capacity form of grid energy storage now readily available worldwide.

FIGURE 10.18 | TYPICAL PUMPED STORAGE POWER PLANT



source IPCC 2012: Special Report on Renewable Energy Sources and Climate Change Mitigation. Prepared by Working Group III of the Intergovernmental Panel on Climate Change, Cambridge University Press.



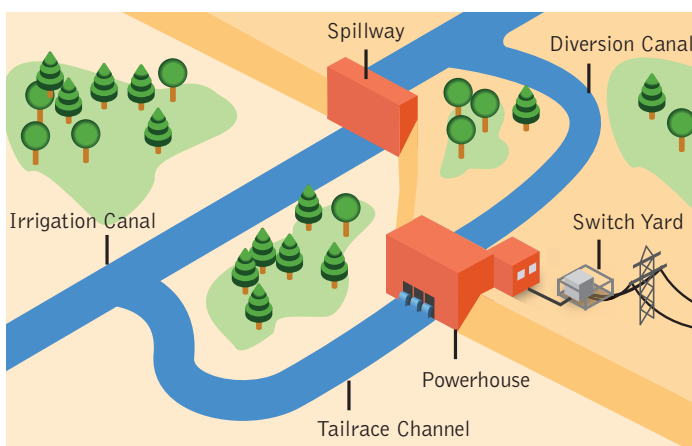
## IN-STREAM TECHNOLOGY USING EXISTING FACILITIES

To optimize existing facilities like weirs, barrages, canals or falls, small turbines or hydrokinetic turbines can be installed for electricity generation. These basically function like a run-of-river scheme, as shown in Figure 10.19. Hydrokinetic devices being developed to capture energy from tides and currents may also be deployed inland for free-flowing rivers and engineered waterways.

**Hydropower – future developments**

A relatively small number of equipment suppliers dominate the market for large hydropower plants (above 10 megawatts). The basic equipment remains the same, though IT has improved efficiency, with additional services ranging from monitoring and diagnostics to advanced control systems. More R&D is needed to produce further progress and reduce the considerable impact of large hydropower on environmental systems and local communities (IRENA-Hydro-2015).<sup>36</sup> The local population must be consulted before projects are further developed.

FIGURE 10.19 | TYPICAL IN-STREAM HYDROPOWER PLANT



source IPCC 2012: Special Report on Renewable Energy Sources and Climate Change Mitigation. Prepared by Working Group III of the Intergovernmental Panel on Climate Change, Cambridge University Press.

## REFERENCES

- 36 (IRENA-HYDRO 2015) HYDROPOWER – TECHNOLOGY BRIEF; IEA-ETSAP AND IRENA TECHNOLOGY BRIEF E06 – FEBRUARY 2015. WWW.ETSAP.ORG – WWW.IRENA.ORG; INTERNATIONAL RENEWABLE ENERGY AGENCY (IRENA); ENERGY TECHNOLOGY SYSTEMS ANALYSIS PROGRAMME.
- 37 (IPCC-SRREN 2012), CHAPTER 6.

There are 3 classes of hydro power plants:

- Large hydropower (>10 MWelectric);
- Small hydropower (≤10 MWelectric)
- Mini-hydro (100 kWe to 1 MWelectric)

Small-scale hydropower (from 1 MW to 10 MW) has a much wider range of designs, equipment, and material. Therefore, expertise in a wider range of fields is crucial towards tapping the potential of local resources affordably and without a detrimental environmental impact (IRENA-Hydro-2015).

Upgrades are an excellent way of getting more energy from existing hydropower facilities – and often the least-cost option. Realistically, 5-10 percent more electricity can be generated at modest cost. Legal and technical hurdles may, however, hamper repowering, for instance when there is limited documentation from decades ago. Today, it is possible to accurately analyse local geology and hydrology in advance in order to assess potential gains from upgrades (IRENA-Hydro-2015). In Energy [R]evolution scenarios, up-grading of existing hydropower plants is of particular importance and preferred to new builds, especially for large power plants.

**Greenpeace does not support large hydropower stations that require large dams and flooding areas but does support small-scale run-of-river power plants.**

## 10.4.13 OCEAN ENERGY

**Wave energy**

In wave power generation, a structure interacts with the incoming waves, converting this energy to electricity through a hydraulic, mechanical or pneumatic power take-off system. The structure is moored or placed directly on the seabed/seashore. Power is transmitted to the seabed by a flexible submerged electrical cable and to shore by a sub-sea cable. Wave power can potentially provide a predictable supply of energy and does not create much visual impact.

Many wave energy technologies are at an early phase of conceptual development and testing. Power plants designs vary to deal with different wave motion (heaving, surging, pitching) water depths (deep, intermediate, shallow) and distance from shore (shoreline, near-shore, offshore).

Shoreline devices are fixed to the coast or embedded in the shoreline. Near-shore devices work at depths of 20-25 m to ~500 m from the shore, where there are stronger, more productive waves. Offshore devices exploit the more powerful waves in water over 25 m deep (IPCC-SRREN 2012).<sup>37</sup> No particular technology is dominant for wave power. Several different systems are being prototyped and tested at sea, with most development being carried out in UK.

A generic scheme for characterizing ocean wave energy generation devices consists of primary, secondary and tertiary conversion stages,<sup>38</sup> which refer to the conversions of kinetic energy (in water) to mechanical energy, and then to electrical energy in the generator. Recent reviews have identified more than 50 wave energy devices at various stages of development,<sup>39</sup> and we have not explored the limits of size in practice.

Utility-scale electricity generation from wave energy will require arrays of devices, and like wind turbines, devices are likely to be chosen for specific site conditions. Wave power converters can be made up from connected groups of smaller generator units of 100 – 500 kW, or several mechanical or hydraulically interconnected modules can supply a single larger turbine generator unit of 2 – 20 MW. However, large waves needed to make the technology more cost effective are mostly a long way from shore which would require costly sub-sea cables to transmit the power. The converters themselves also take up large amounts of space.

Wave energy systems may be categorised by their genus, location and principle of operation as shown in Figure 10.20.

#### OSCILLATING WATER COLUMNS

Oscillating water columns use wave motion to induce different pressure levels between the air-filled chamber and the

atmosphere.<sup>40</sup> Air is pushed at high speed through an air turbine coupled to an electrical generator (Figure 10.21), creating a pulse when the wave advances and recedes, as the air flows in two directions. The air turbine rotates in the same direction, regardless of the flow. A device can be: a fixed structure above the breaking waves (cliff-mounted or part of a breakwater); bottom-mounted near shore; or it can be a floating system moored in deeper waters.

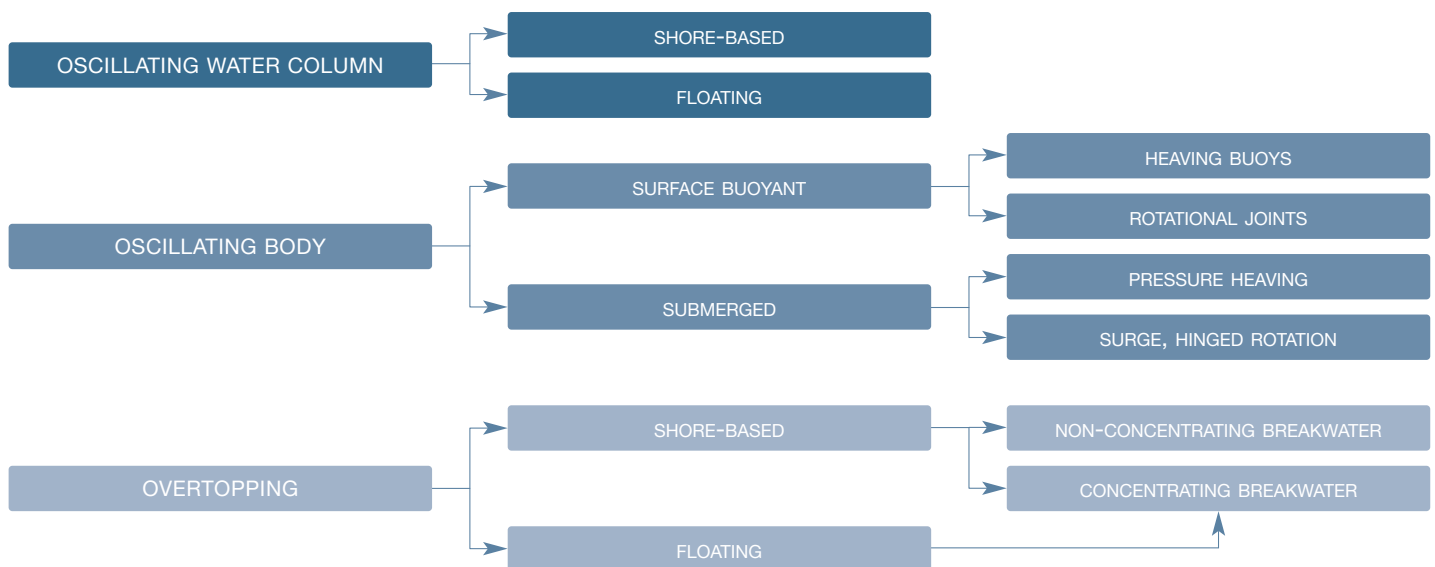
#### OSCILLATING-BODY SYSTEMS

Oscillating-body systems use the incident wave motion to make two bodies move in oscillation to drive the power take-off system.<sup>41</sup> They can be surface devices or, less often, fully submerged. Surface flotation devices are generally referred to as ‘point absorbers’, because they are non-directional. Some oscillating body devices are fully submerged and rely on oscillating hydrodynamic pressure to extract the wave energy. Lastly, hinged devices sit on the seabed relatively close to shore and harness the horizontal surge energy of incoming waves.

#### OVERTOPPING DEVICES

Overtopping devices convert wave energy into potential energy by collecting surging waves into a water reservoir at a level above the free water surface.<sup>42</sup> The reservoir drains down through a conventional low-head hydraulic turbine. These systems can float offshore or be incorporated into shorelines or man-made breakwaters (Figure 10.23).

FIGURE 10.20 | WAVE ENERGY: CLASSIFICATION BASED ON PRINCIPLES OF OPERATION



source Falcao 2009.

#### REFERENCES

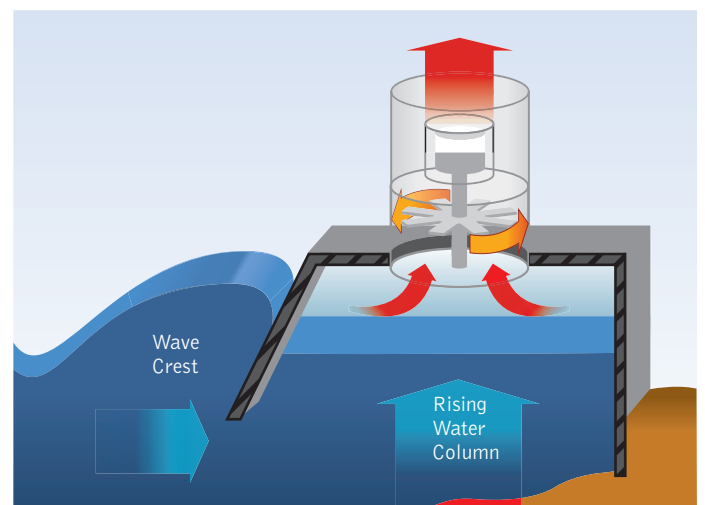
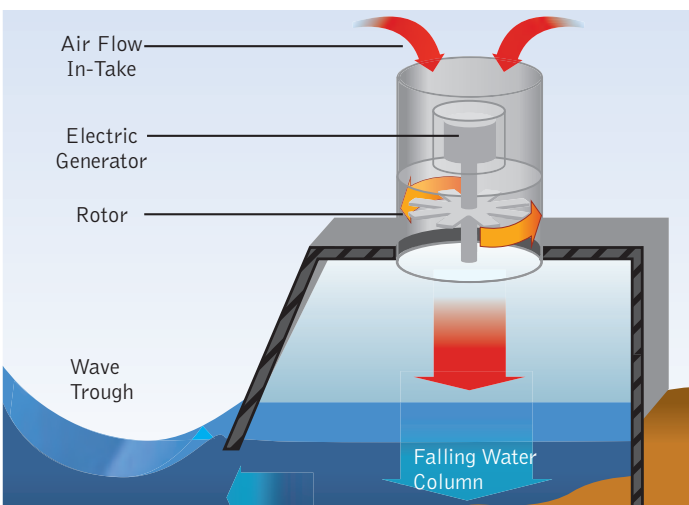
- 38 (KHAN ET AL., 2009).
- 39 FALCAO, 2009; KHAN AND BHUYAN, 2009; US DOE, 2010.
- 40 FALCAO ET AL., 2000; FALCAO, 2009.
- 41 FALCAO, 2009.
- 42 FALCAO, 2009.

POWER TAKE-OFF SYSTEMS

Power take-off systems are used to convert the kinetic energy, air flow or water flow generated by the wave energy device into a useful form, usually electricity. A large number of different technology options are described in the literature.<sup>43</sup> The overall concept is that real-time wave

oscillations will produce corresponding electrical power oscillations. In practice, some method of short-term energy storage (in seconds) may be needed to smooth energy delivery. These devices would probably be deployed in arrays because the cumulative power generated by several devices will be smoother than from a single device.

FIGURE 10.21 | OSCILLATING WATER COLUMNS



source IPCC 2012: Special Report on Renewable Energy Sources and Climate Change Mitigation. Prepared by Working Group III of the Intergovernmental Panel on Climate Change, Cambridge University Press.

FIGURE 10.22 | OSCILLATING-BODY SYSTEMS

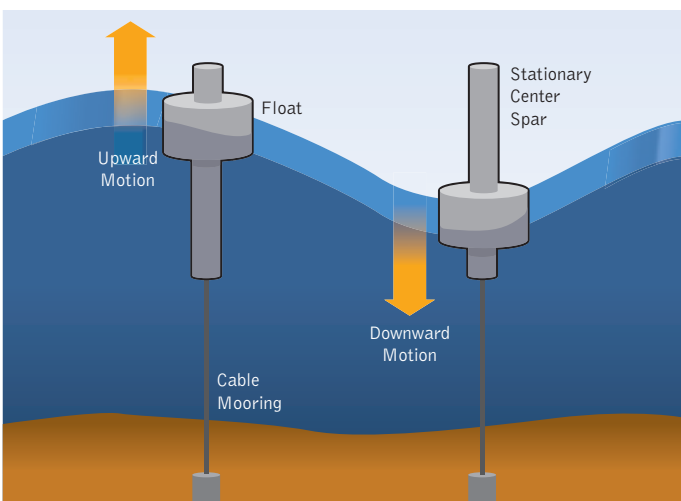
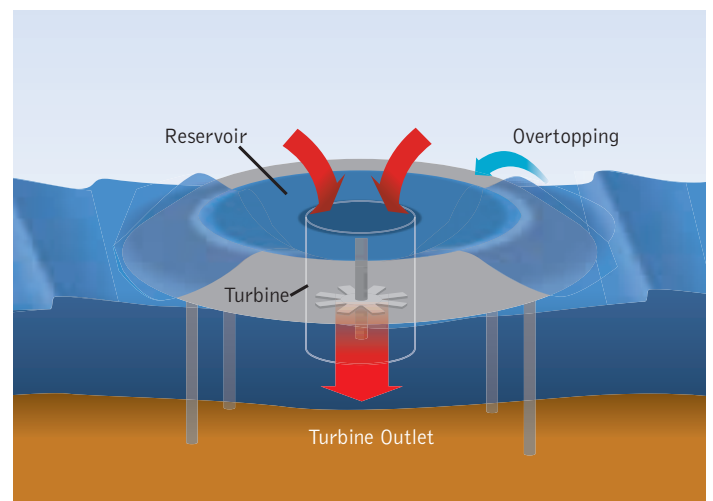


FIGURE 10.23 | OVERTOPPING DEVICES



source IPCC 2012: Special Report on Renewable Energy Sources and Climate Change Mitigation. Prepared by Working Group III of the Intergovernmental Panel on Climate Change, Cambridge University Press.

REFERENCES

43 KHAN AND BHUYAN, 2009.

### Tidal range

Tidal range hydropower has been tested in estuarine developments where a barrage encloses an estuary, which creates a single reservoir (basin) behind it with conventional low-head hydro turbines in the barrage. Alternative configurations of multiple barrages have been proposed where basins are filled and emptied at different times, with turbines located between the basins. Multi-basin schemes may offer more flexible power generation availability than normal schemes because they could generate power almost continuously.

Recent developments focus on single or multiple offshore basins away from estuaries ('tidal lagoons'), which could provide more flexible capacity and output with little or no impact on delicate estuarine environments. This technology uses commercially available systems. The conversion mechanism most widely used to produce electricity from tidal range is the bulb-turbine.<sup>44</sup> Examples of power plants with bulb turbines technology include a 240 MW power plant at La Rance in northern France<sup>45</sup> and the 254 MW Sihwa Barrage in the Republic of Korea, which is nearing completion.<sup>46</sup>

Some favourable sites with very gradually sloping coastlines are well suited to tidal range power plants, such as the Severn Estuary between southwest England and South Wales. Current feasibility studies there include options such as barrages and tidal lagoons. The average capacity factor for tidal power stations has been estimated from 22.5% to 35%.<sup>47</sup>

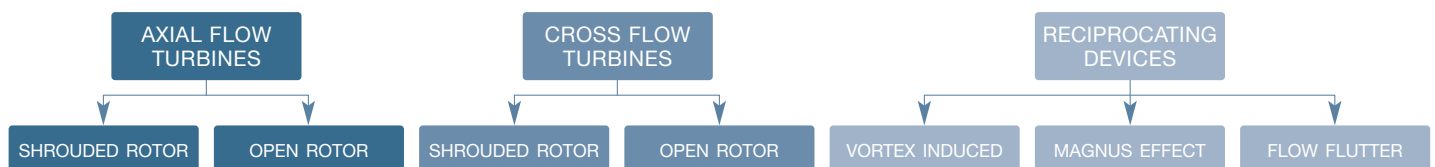
### Tidal and ocean currents

To capture energy from tidal currents, a device can be fitted underwater to a column fixed to the sea bed with a rotor to generate electricity from fast-moving currents. Technologies that extract kinetic energy from tidal and ocean currents are under development; tidal energy converters are the most common to date, designed to generate as the tide travels in both directions. Devices types include axial-flow turbines, cross-flow turbines and reciprocating devices. Axial-flow turbines (Figure 10.26 see below) work on a horizontal axis, while cross-flow turbines may operate about a vertical axis (Figure 10.27 see below) or a horizontal axis with or without a shroud to accentuate the flow. A single unit can have multiple turbines (Figure 10.27).

Marine turbine designs look somewhat like wind turbines but must contend with reversing flows, cavitation and harsh underwater marine conditions (salt water corrosion, debris, fouling, etc.). Axial flow turbines must be able to respond to reversing flow directions, while cross-flow turbines continue to operate regardless of current flow direction. Rotor shrouds (also known as cowlings or ducts) can enhance hydrodynamic performance by increasing the speed of water through the rotor and reducing losses at the tips. Some technologies in the conceptual stage of development are based on reciprocating devices incorporating hydrofoils or tidal sails. Two prototype oscillating devices have been trialled at open sea locations in the UK.<sup>48</sup>

The development of tidal current resources will require multiple machines deployed in a similar fashion to a wind farm, and siting will need to take into account wake effects.<sup>49</sup>

FIGURE 10.24 | CLASSIFICATION OF CURRENT TIDAL AND OCEAN ENERGY TECHNOLOGIES (PRINCIPLES OF OPERATION)



source IPCC-SRREN 2012.

#### REFERENCES

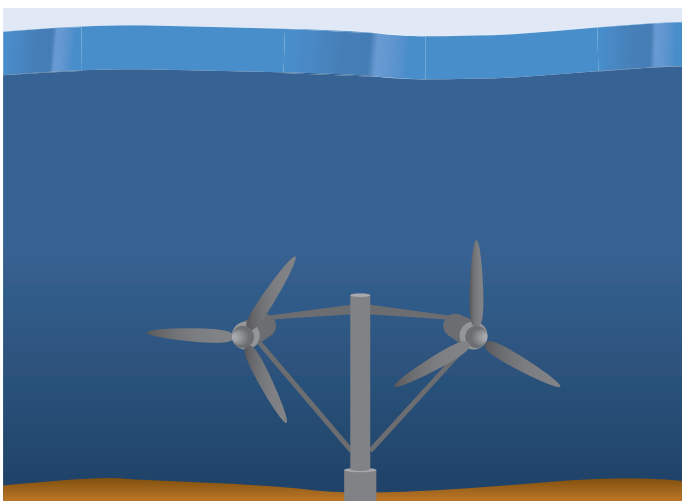
- 44 BOSC, 1997.
- 45 ANDRE, 1976; DE LALEU, 2009.
- 46 PAIK, 2008.
- 47 CHARLIER, 2003; ETSAP 2010B.
- 48 ENGINEERING BUSINESS, 2003; TSB, 2010.
- 49 PEYRARD ET AL., 2006.

Capturing the energy of open-ocean current systems is likely to require the same basic technology as for tidal flows but with some different infrastructure. Deep-water applications may require neutrally buoyant turbine/generator modules with mooring lines and anchor systems. They could also be attached to other structures, such as offshore platforms.<sup>50</sup> These modules will also have hydrodynamic lifting designs to allow for optimal and flexible vertical positioning.<sup>51</sup> Systems to capture energy from open ocean current systems may have larger rotors, as there is no restriction based on the channel size.

### Ocean Energy – Future Developments

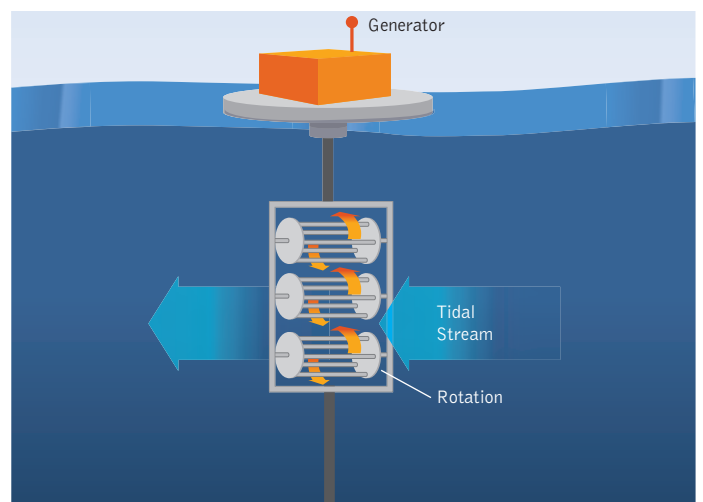
Ocean energy can play a significant role for the power supply of islands and coastal regions. A combination with offshore wind farms, ocean energy power plants might help to integrate larger shares of flexible one-shore and/or solar photovoltaic electricity. Greenpeace supports the developments of ocean energy in a sustainable manner.

FIGURE 10.25 | TWIN TURBINE HORIZONTAL AXIS DEVICE



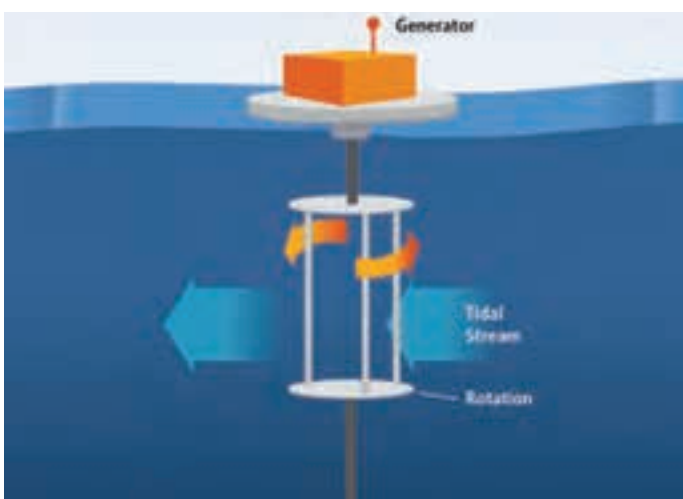
source IPCC 2012: Special Report on Renewable Energy Sources and Climate Change Mitigation. Prepared by Working Group III of the Intergovernmental Panel on Climate Change, Cambridge University Press.

FIGURE 10.27 | CROSS FLOW DEVICE



source IPCC 2012: Special Report on Renewable Energy Sources and Climate Change Mitigation. Prepared by Working Group III of the Intergovernmental Panel on Climate Change, Cambridge University Press.

FIGURE 10.26 | VERTICAL AXIS DEVICE



source IPCC 2012: Special Report on Renewable Energy Sources and Climate Change Mitigation. Prepared by Working Group III of the Intergovernmental Panel on Climate Change, Cambridge University Press.

### REFERENCES

- 50 VANZWIETEN ET AL., 2005.
- 51 VENEZIA AND HOLT, 1995; RAYE, 2001; VANZWIETEN ET AL., 2005.

## 10.5 POWER GRID TECHNOLOGIES – INFRASTRUCTURE FOR RENEWABLES

With increasing market shares of renewable power generation, there will be less space for base load power plants. As a result conventional power plants cannot run in base load mode anymore, which increases costs of operation and therefore lowers the profit on each kWh sold. The integration of large-scale renewable energy requires a variety of existing grid technologies applied in a new context and with new operational concepts. This section provides a short overview of technologies and operational concepts used for the integration of large shares of renewables and are based on Greenpeace International's reports about power grids published between 2009 and 2014 (GPI- EN 2014).<sup>52</sup>

Smart-grid technology will play a significant role, in particular by integrating demand-side management into power system operation. The future power supply will not consist of a few centralized power plants, but of numerous smaller generation units, such as solar panels, wind turbines and other renewable units, partly on the distribution network and partly concentrated in large power plants (such as offshore wind farms). Smart-grid solutions will help to monitor and integrate this diversity into power system operation and at the same time will make interconnection simpler.

The tradeoff is that power system planning will become more complex due to the larger number of generation assets and the significant share of variable power generation causing constantly changing power flows in the power systems. Smart-grid technology will be needed to support power system planning, i.e. actively support day-ahead planning and power system balancing by providing real-time information about the status of the network and the generation units in combination with weather forecasts. Smart-Grid technology will also play a significant role in making sure systems can meet the peak demand at all times. Smart-Grid technology will make better use of distribution and transmission assets, thereby limiting the need for transmission network extension to the absolute minimum.

**Smart grids use information and communication technology (ICT) to enable a power system based on renewable energy sources.**

ICT in smart grids is used to:

- easily interconnect a large number of renewable generation assets into the power system (plug and play)
- create a more flexible power system through large-scale demand-side management and by integrating storage to balance the impact of variable renewable generation resources
- provide the system operator with a better information about the state of the system, which so they can operate the system more efficiently

- minimize network upgrades using of network assets efficiently and supporting an efficient coordination of power generation over very large geographic areas needed for renewable energy generation.

### 10.5.1 DEMAND SIDE MANAGEMENT

In reality, load varies over time which means that additional flexible power generation resources are required to provide the right amount of power. For rural areas, typical technologies are combined-cycle gas turbines (CCGT) or hydro-power stations with a sufficient storage capacity to follow the daily load variations. In conventional island power systems, typically a number of small diesel generators (gen-sets) are used to provide 24/7 supply. Several gen-sets have to operate continuously at the point of their highest efficiency, while one is used to follow the load variations.

The impact of adding renewable power generation to a conventionally centralized or island power system will affect the way in which a conventionally designed electricity system runs. The level of impact depends on the renewable energy technology: Biomass, geothermal-, concentrated solar- and hydropower with storage can regulate power output and therefore can supply base load as well as peak load.

Hydropower without storage (run-of- river), photovoltaic and wind power depends on the available natural resources, so the power output is variable. Sometimes these renewable energy sources are sometimes described as 'intermittent' power sources; however, the terminology is not correct as intermittent stands for uncontrollable, i.e. non-dispatchable, but the power output of these generation plants can be forecast, so they can be dispatched.

Furthermore, they can always be ramped down if needed. There are two main types of impacts to consider when introducing renewable energy to micro-grids: the balancing impact and reliability impact.

**Balancing impact** To relates to the short-term adjustments needed to manage fluctuations over a period ranging from minutes to hours before the time of delivery. In power systems without variable power generation, there can be a mismatch between demand and supply. The reasons could be that the energy load was not forecast correctly, or a conventional power plant is not operating as it is scheduled, for instance when a power station trips due to a technical problem.

Adding a variable power generation source increases the risk that the forecast power generation in the power system will not be reached, for instance due to a weather system moving faster than predicted into the area. The overall impact on the system depends on how large and how widely distributed the variable power sources are. A certain amount of wind power distributed over a larger geographical area will have a lower

#### REFERENCES

<sup>52</sup> (GPI-EN 2014) POWER [R] 2030 -. A EUROPEAN GRID FOR 3/4 RENEWABLE ELECTRICITY BY 2030; GREENPEACE INTERNATIONAL / ENERGINAUTICS; MARCH 2014.

impact on system balancing than the same amount of wind power concentrated in one single location, as geographical distribution will smoothen out the renewable power generation.

System balancing is relevant to:

- **Day-ahead planning**, which needs to make sure that sufficient generation is available to match expected demand taking into account forecasted generation from variable power generation sources (typically 12 to 36 hours ahead);
- **Short-term system balancing**, which allocates balancing resources to cover events such as a mismatch between forecasted generation/demand or sudden loss of generation (typically seconds to hours ahead planning).

In island power systems, both aspects must be handled automatically by the system.

**Reliability impact** is the extent to which sufficient generation will be available to meet peak demands at all times. No electricity system can be 100% reliable, since there will always be a small chance of major failures in power stations or transmission lines when demand is high. As renewable power production is often more distributed than conventional large-scale power plants, it reduces the risk of sudden drop-outs of major individual production units. On the other hand, variable renewable power generation reduces the probability that generation is available at the time of high demand, thus adding complexity to system planning.

Reliability is important for long-term system planning, which assesses the system adequacy typically two to 10 years ahead. Long-term system planning with variable generation sources is a challenge, because of the actual geographical location of the resource. To get a high level of renewable energy into the system, it ideally must be situated at some distance from each other, for example using solar power from Southern Europe when there is no or limited wind power available in Northern Europe.

In island power systems, all power generation is typically close to each other, which means that there must be a mix of different generation technologies in the island system or that they must be partly over-designed to make sure that there is always sufficient generation capacity available. This is typically done by adding some back-up diesel gen-sets. In addition, island power systems can adjust power demand to meet power supply, rather than the other way round. This approach is called demand-side management. An example of a “flexible” load in island systems for demand-side management is water pumps and irrigation pumps, which can be turned on and off depending on how much electricity supply there is.

### 10.5.2 “OVERLAY” OR “SUPER GRID” – THE INTERCONNECTION OF SMART GRIDS

Based on the current technology development of energy storage technologies, it is difficult to envision that energy storage could provide a comprehensive solution to this challenge. While different storage technologies such as electrochemical batteries are already available today, it is not clear whether large-scale electricity storage, other than pumped hydropower described in the previous section, will become technically and economically viable.

Feasible storage systems would have to cover most of the European electricity supply during up to two successive weeks of low solar radiation and little wind – difficult to envision based on current technology development. To design a power system that can adequately react to such extreme situations, a substantial amount of planning is needed in order to ensure available generation capacity together with sufficient network capacity to match demand. Different timescales must be considered:

- Long-term system plans to assess the system adequacy over the coming years (typically a time horizon of 2 to 10 years ahead)
- Day-ahead planning, making sure that sufficient generation is available to match expected demand (typically 12 to 36 hours ahead)
- Short-term balancing, covering events such as a mismatch between forecasted generation/demand or sudden loss of generation (typically seconds to hours-ahead planning)

#### Benefits of a Super Grid

Starting around 1920, each load center in Europe had its own isolated power system. With the development of transmission lines using higher voltages, the transport of power over larger distances became feasible. Soon, the different centers were interconnected. In the beginning, only stations in the same region were interconnected. Over the years, technology developed further, and maximum possible transmission line voltage increased step by step.

There were two main drivers of extending network structure:

- Larger transmission networks and high voltage lines meant suppliers could follow the aggregated demand of a large number of customers, instead of the demand variation of one customer - which can change significantly over time - with one generation resource. The demand of those aggregated customers became easier to predict and generation scheduling therefore significantly easier.
- The larger transmission networks created economies of scale by installing larger generation units. In the 1930s, the most cost-effective size of thermal power stations was about 60 MW. In the 1950s, it was 180 MW, and by the 1980s about 1,000 MW. This approach made only

economic sense because extending the power system was cheaper than adding local generation capacity.

The approach includes some major risks, like the failure of a large power station or the interruption of a major transmission line, which can interrupt of the power system over a large area. To be better prepared for such situations national transmission systems in Europe and elsewhere were interconnected across borders. Countries can help each other in case of emergency situations by cooperating in the organization of spinning reserve, reserve capacity and frequency control.

Shifting to an energy mix with over 90% of the electricity supply coming from renewable energy sources will also require a significant redesign of the transmission network to adapt to the needs of the new generation structure. The right kind of grid provides an economic, reliable and sustainable energy supply.

In principal, over-sizing local generation locally would reduce the need for large-scale renewable generation elsewhere as well as upgrading the transmission network. In this case the local power system will evolve into a hybrid system that can operate without any outside support.

However, making local plants bigger (over-sized) is less economical than installing large-scale renewable energy plants at a regional scale and integrating them into the power system via extended transmission lines. The allocation of 70% distributed renewable generation and 30% large-scale renewable generation is not based on a detailed technical or economic optimization; in each location, the optimum mix is specific to local conditions. Further detailed studies on regional levels will be needed to better quantify the split between distributed and large-scale renewable generation better.

An appropriately designed transmission system is the solution in both cases as it can be used to transmit the required electricity from areas with surplus of generation to areas that have an electricity deficit.

In general, the transmission system must be designed to cope with:

- Long-term issues: Extreme variations in the availability of natural resources from one year to another; for instance, the output of wind turbines in any given area can vary by up to 30% from one year to the next. For hydropower, the variations can be even larger
- Medium-term issues: extreme combinations in the availability of natural resources, such as no wind over main parts of Europe during the winter, when solar radiation is low

- Short-term issues: Significant mismatch between forecasted wind or solar production and actual production with significant impact on power system operation in the range of 15 minutes to 3 hours
- Loss of a significant amount of generation due to unscheduled break-down or network interruption, impact within milliseconds. The mainland European power system is currently designed to cope with a maximum sudden generation loss of 3,000 MW. Whether this level is sufficient for the future depends, for example, on the maximum transmission capacity of a single transmission line. Most likely the maximum transmission capacity of a single transmission in the future HVDC Super Grid will exceed a capacity of 3,000 MW; hence, sufficient spare generation and/or network capacity must be considered when redesigning the power system (considered in the simulation report by loading the Super Grid to a maximum of 70%).

#### Super Grid Transmission Options

In principal different technical options exists for the redesign of the onshore transmission network. In the following, the following technical options are briefly presented, followed by a general comparison.

- HVAC (High Voltage Alternating Current)
- HVDC LCC (High voltage direct current system using line commutated converter)
- HVDC VSC (High voltage direct current system using voltage source converter)
- Other technical solutions

#### 10.5.3 HVAC

High voltage AC transmission (HVAC) using overhead lines has become a leading technology in electrical networks.<sup>53</sup> Its advantage is in using transformers to increase the typical, rather low voltage from the generators to higher voltage levels, which is a significantly cheaper approach than the AC/DC converter stations for the HVDC technologies. Transmission over long distances with low or medium voltage will result in high and prohibitively expensive losses, so high voltage AC (400 kV or more) over medium distance (a few hundred kilometers) is typically the most cost effective solution. As AC systems develop, there are increases in transmission voltage. Typically, doubling the voltage quadruples the power transfer capability. Consequently, the evolution of grids in most countries is characterized by the addition of network layers of higher and higher voltages.

Today, the highest HVAC voltage used is around 800 kV for overhead lines. The Canadian company Hydro Quebec, for instance, operates a massive 735 kV transmission system using overhead lines; the first line was in operation 1965. 1000 kV and 1200 kV AC has been tested in several test-

#### REFERENCES

<sup>53</sup> HVAC CABLE SYSTEMS ARE CURRENTLY LESS ATTRACTIVE AS CABLE LOSSES ARE HIGHER AND TRANSMISSION CAPACITY IS LESS THAN WITH HVAC OVERHEAD LINES.



installations and even short-term commercial applications. There are several challenges involved in building such lines and new equipment needing to be developed includes transformers, breakers, transformers, and switches.

The major advantage of an AC-based system is the flexibility with which loads and generation along the route can be connected. This is especially important if the transmission route passes through a highly populated area and if many local generation facilities are located at many places along the route. The disadvantage of HVAC systems are the comparatively high costs for transmission of large capacity (> 1,000 MW) over very long distances (> 1000 km) due to the additional equipment required for keeping the voltage level on the overhead lines, for instance.

#### 10.5.4 HVDC LCC

The advantage of line commutated converter (LCC) high voltage DC (HVDC) connections is certainly their proven track record. The first commercial LCC HVDC link was installed in 1954 between the island of Gotland and the Swedish mainland. The link was 96 km long, rated at 20 MW, and used a 100 kV submarine cable. Since then, LCC based HVDC technology has been installed in many locations in the world, primarily for bulk power transmission over long geographical distances and for interconnecting power systems, such as island systems in Japan and New Zealand. Other well-known examples for conventional HVDC technology are:

- The 1,354 km Pacific Interie DC link with a rating of 3,100 MW at a DC voltage of  $\pm 500$  kV
- The Itaipu link between Brazil and Paraguay, rated at 6,300 MW at a DC voltage of  $\pm 600$  kV (2 bipoles x 3,150 MW)

The total conversion efficiency from AC to DC and back to AC using the two converters lies in the range of 97 to 98 % and depends on the design details of the converter stations. A system design with a 98 % efficiency will have higher investment costs compared to a design with lower efficiency. The advantage of an LCC HVDC solution are comparatively low losses – in the order of 2-3 % for a 500 MW transmission over 100 km, including losses in converters and transmission. In addition, the higher transmission capacity of a single cable compared to HVAC transmission and voltage source converter transmission can be an advantage when transmitting large capacities. The disadvantage of the HVDC LCC design is lack of power system support capability. Typically, a strong HVAC network is required on both sites of the HVDC LCC connection. Hence, building up an entire HVDC back-bone network using HVDC LCC technology that has to support the underlying HVAC network is technically challenging and only possible with the installation of additional equipment such as Statcoms (= Static Synchronous Compensator).

#### 10.5.5 HVDC VSC

The voltage source converter (VSC) based HVDC technology is capturing more and more attention. This comparatively new technology has only become possible due to advances in high power electronics, namely Insulated Gate Bipolar Transistors (IGBTs). Pulse Width Modulation (PWM) can then be used for the VSC converter, as opposed to the thyristor line-commutated converters used in conventional HVDC technology.

The first commercial VSC-based HVDC link was installed by ABB on the Swedish island of Gotland in 1999. It is 70 km long, with 60 MVA at  $\pm 80$  kV. The link was mainly built in order to provide voltage support for the large amount of wind power installed in the South of Gotland. Today about 10 VSC-based HVDC links are in operation world-wide. Key projects are:

- In 2000, the Murraylink was built in Australia with a length of almost 180 km. This connection was the longest VSC-based HVDC link in the world until 2009. It has a capacity of 220 MVA at a DC voltage of  $\pm 150$  kV
- The Bard Offshore 1 Project BorWind in Germany connects a 400 MW offshore wind farm to the onshore grid using a 203 km long cable, operating at a DC voltage of  $\pm 150$  kV
- The longest HVDC VSC project is the Caprivi link in Namibia. It is 970 km long and operates at  $\pm 350$  kV, the highest voltage level used so far for HVDC VSC projects, to transmit a capacity of 300 MW.

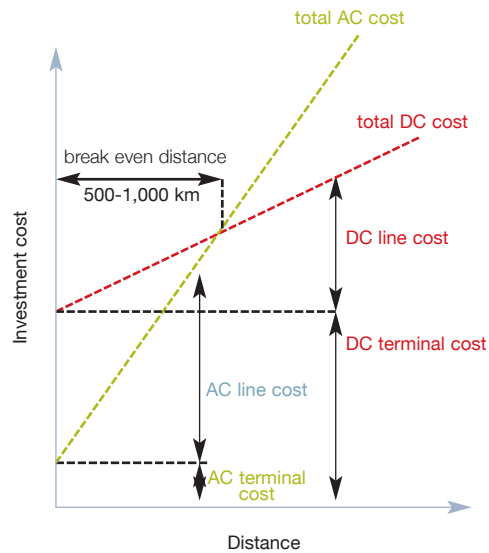
The total efficiency of a VSC-based HVDC system is slightly less than that of a LCC HVDC system, but efficiency is expected to improve with future technical development. Also, rating per converter is presently limited to approximately 400-500 MW, while the cable rating at  $\pm 150$  kV is 600 MW. More cable and converter stations are required for a VSC-based HVDC solution compared to an LCC-based HVDC solution; however, manufacturers are already working on converter stations with higher ratings and increased cable ratings. The significant advantages of VSC-based HVDC solutions are its power system support capabilities, such as independent control of active and reactive power. In addition, a VSC-based HVDC link does not require a strong AC network, it can even start up against a non-load network. Building up a VSC-based HVDC backbone network will be technically easier than using LCC-based HVDC technology. However, multi-terminal VSC HVDC systems are also new for the power system industry, so there will a learning curve to achieve it.

### Comparison of transmission solutions

Table 10.2 compares the three standard transmission solutions. The technical capabilities of each system can probably be improved by adding additional equipment to the overall system solution.

The cost of transmitting electricity is dominated by the investment cost of the transmission lines and by the electricity losses during transmission. At present, overhead lines are predominant since costs of overhead lines are about 20 % of that for ground cables. The transmission losses of HVAC overhead lines are roughly twice as high as those of HVDC. On the one hand, the cost of overhead lines is similar for the lower voltage level, but at 800 kV HVDC lines are much less expensive than comparable AC lines. On the other hand, AC/DC converter stations for HVDC technology are considerably more expensive than the transformer stations of AC systems. Therefore, for shorter distances and lower voltages AC is typically the most economical solution, while HVDC lines are applied at distances well over 500 km.

**FIGURE 10.28 | COMPARISON OF AC AND DC INVESTMENT COSTS USING OVERHEAD LINES**



source Energynautics; Dr Thomas Ackermann 2014.  
note The break even point is typically between 500 to 1000 km.

**TABLE 10.2 | OVERVIEW OF THE THREE MAIN TRANSMISSION SOLUTIONS**

	HVAC	LCC HVDC	VSC HVDC
MAXIMUM AVAILABLE CAPACITY PER SYSTEM	Cable system: <ul style="list-style-type: none"> <li>• 200 MW at 150 kV;</li> <li>• 350 MW at 245 kV;</li> </ul> Overhead lines: <ul style="list-style-type: none"> <li>• 2,000 MW at 800 kV</li> <li>• 4,000 MW at 1000 kV (under development)</li> </ul>	Cable system: <ul style="list-style-type: none"> <li>• ~ 1200 MW</li> </ul> Overhead lines: <ul style="list-style-type: none"> <li>• 3,150 MW at ± 600 kV</li> <li>• 6,400 MW at ± 800 kV (under development)</li> </ul>	Cable/Overhead: <ul style="list-style-type: none"> <li>• 400 MW</li> <li>• 500 - 800 MW announced</li> </ul>
VOLTAGE LEVEL	Cable system: <ul style="list-style-type: none"> <li>• Up to 245 kV realistic, short cables up to 400 kV possible</li> </ul> Overhead lines: <ul style="list-style-type: none"> <li>• Up to 800 kV</li> <li>• 1,000 kV under development</li> </ul>	Cable system: <ul style="list-style-type: none"> <li>• Up to ± 500 kV</li> </ul> Overhead lines: <ul style="list-style-type: none"> <li>• Up to ± 600 kV</li> <li>• ± 800 kV under development</li> </ul>	Cable: <ul style="list-style-type: none"> <li>• Up to ± 150 kV, higher voltages announced</li> </ul> Overhead lines: <ul style="list-style-type: none"> <li>• Up to ± 350 kV</li> </ul>
TRANSMISSION CAPACITY DISTANCE DEPENDING?	Yes	No	No
TOTAL SYSTEM LOSSES	Distance depending	2 - 3 % (plus requirements for ancillary services offshore)	5 – 10 %
BLACK START CAPABILITY	(Yes)	No	Yes
TECHNICAL CAPABILITY FOR NETWORK SUPPORT	Limited	Limited	Large range of possibilities.
SPACE REQUIREMENTS FOR SUBSTATION.	Small	Depending on capacity. Converter larger than VSC.	Depending on capacity. Converter smaller than LCC but larger than HVAC substation.

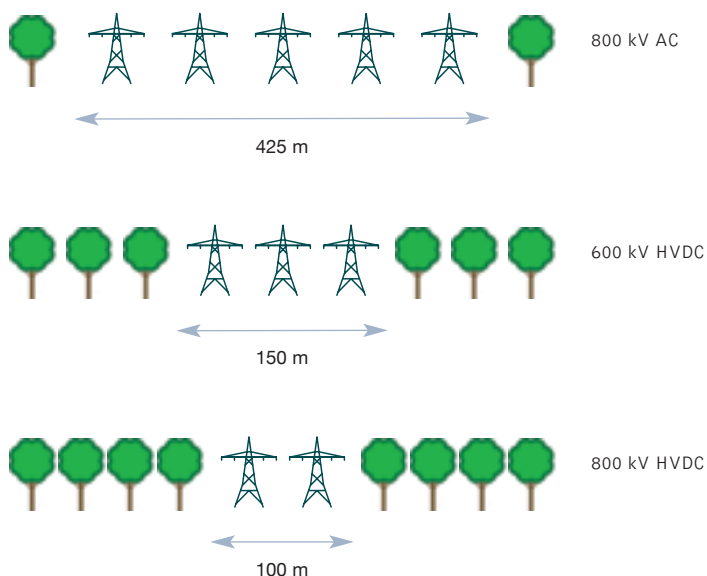
source energynautics/Greenpeace/Teske 2014 - powe[r] 2030.

The most economical system design is typically a combination of HVAC and HVDC technology. HVAC is a cost-effective and flexible solution over medium distances (up to 1,000 km), for instance to distribute power along the route to different load centers or to collect locally distributed generation and transmit the surplus electricity to other regions. HVDC technology can be used as an overlaying network structure to transmit bulk power, i.e. large capacity, over long distances to the areas where the energy is needed. An HVDC Super Grid will have only a very limited number of connection points, because the substation (converter station) costs are significant.

In addition, an HVAC solution will require significantly more lines than HVDC solutions. The transmission of 10,000 MW or 10 GW, for instance, can be achieved with two lines using 800 kV and applying LCC HVDC technology, while transmitting the same power with 800 kV AC would require five lines. For a given transmission capacity of 10 GW, the space requirement of HVDC overhead lines can be four times lower than that of HVAC lines (Figure 10.29). While an 800 kV HVAC line would require a width of 425 meters over the total length of a power link of 10 GW, a HVDC line of the same capacity would only require a width of 100 meters. There are thus considerable differences in the environmental impact of both technologies.

A final advantage of using HVDC technology is that it is easier to move the entire HVDC Super grid underground by using HVDC cables. This approach will be more costly, but following existing transporting routes (laying the cables along motorways, railway tracks or even in rivers) will allow a fast roll-out of the HVDC Supergrid infrastructure and reduce the visual impact of the installation.

**FIGURE 10.29 | COMPARISON OF THE REQUIRED NUMBER OF PARALLEL PYLONS AND SPACE TO TRANSFER 10 GW OF ELECTRIC CAPACITY**



source Energynautics; Dr Thomas Ackermann 2014.

## 10.6 RENEWABLE HEATING AND COOLING TECHNOLOGIES

Renewable heating and cooling has a long tradition in human culture. Heat can come from the sun (solar thermal), the earth (geothermal), ambient heat and plant matter (biomass). Solar heat for drying processes and wood stoves for cooking have been used for so long that they are labeled “traditional”, but today’s technologies are far from old-fashioned. Over the last decade, there have been improvements to a range of traditional applications, many of which are already economically competitive with fossil-fuel based technologies or starting to be.

This chapter presents the current range of renewable heating and cooling technologies and gives a short outlook of the most sophisticated technologies, integrating multiple suppliers and users in heat networks or even across various renewable energy sources in heating and cooling systems. Some of the emerging areas for this technology are space heating / cooling and industrial process heat.

### 10.6.1 SOLAR THERMAL TECHNOLOGIES

Solar thermal energy has been used for the production of heat for centuries but has become more popular and developed commercially for the last thirty years. Solar thermal collecting systems are based on a centuries-old principle: the sun heats up water contained in a dark vessel.

The technologies on the market now are efficient and highly reliable, providing energy for a wide range of applications in domestic and commercial buildings, swimming pools, for industrial process heat, in cooling and the desalination for drinking water.

Although mature products exist to provide domestic hot water and space heating using solar energy, in most countries they are not yet the norm. A big step towards an Energy [R]evolution is integrating solar thermal technologies into buildings at the design stage or when the heating (and cooling) system is being replaced, lowering the installation cost.

#### Swimming pool heating

Pools can make simple use of free heating, using unglazed water collectors. They are mostly made of plastic, have no insulation and reach temperatures just a few degrees above ambient temperature. Collectors used for heating swimming pools and are either installed on the ground or on a nearby rooftop; and they pump swimming pool water through the collector directly. The size of such a system depends on the size of the pool as well as the seasons in which the pool is used. The collector area needed is about 50 % to 70 % of the pool surface. The average size of an unglazed water collector system installed in Europe is about 200 m<sup>2</sup>.<sup>54</sup>

#### REFERENCES

<sup>54</sup> WEISS, W. ET AL. (2011): SOLAR HEAT WORLDWIDE - MARKETS AND CONTRIBUTION TO THE ENERGY SUPPLY 2009. IEA SOLAR HEATING AND COOLING PROGRAMME, MAY 2011. INTERNATIONAL ENERGY AGENCY (IEA), PARIS, FRANCE.

### Domestic hot water systems

The major application of solar thermal heating so far is for domestic hot water systems. Depending on the conditions and the system's configuration, most of a building's hot water requirements can be provided by solar energy. Larger systems can additionally cover a substantial part of the energy needed for space heating. Two major collector types are:

#### VACUUM TUBES

The absorber inside the vacuum tube absorbs radiation from the sun and heats up the fluid inside. Additional radiation is picked up from the reflector behind the tubes. Whatever the angle of the sun, the round shape of the vacuum tube allows it to reach the absorber. Even on a cloudy day, when the light is coming from many angles at once, the vacuum tube collector can still be effective. Most of the world's installed systems are this type, especially in the world's largest market: China. This collector type consists of a row of evacuated glass tubes with the absorber placed inside. Due to the evacuated environment, there are less heat losses. The systems can reach operating temperatures of at least 120 °C; however, the typical use of this collector type is in the range of 60°C to 80°C. Evacuated tube collectors are more efficient than standard flat-plate collectors but generally also more costly.

#### FLAT PLATE OR FLAT PANEL

This is basically a box with a glass cover which sits on the roof like a skylight. Inside is a series of copper or aluminium

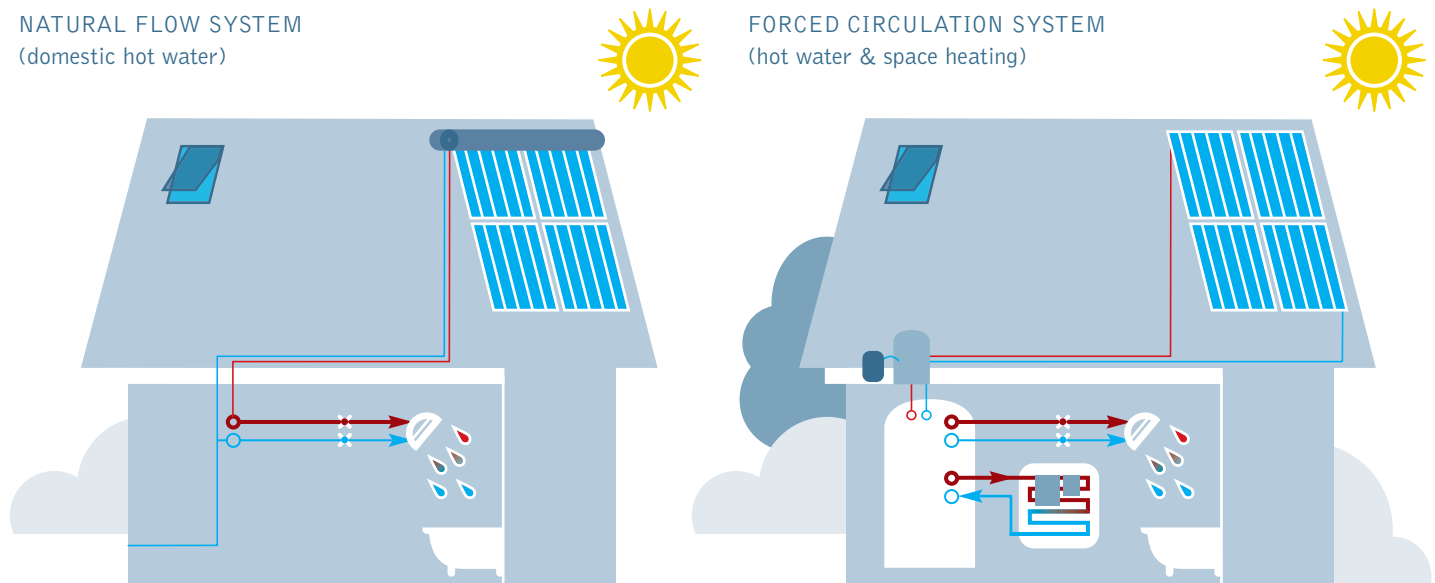
tubes with copper fins attached. The entire structure is coated in a black substance designed to capture the sun's rays. In general, flat plate collectors are not evacuated. They can reach temperatures of about 30°C to 80°C<sup>55</sup> and are the most common collector type in Europe.

There are two different way how the water flow is handle in solar heating, which influences the overall system cost.

#### THERMO-SIPHON SYSTEMS

The simple form of a thermo-siphon solar thermal system uses gravity as a natural way to transfer hot water from the collector to the storage tank. No pump or control station is needed, and many are applied as direct systems without a heat exchanger, which reduces system costs. The thermo-siphon is relatively compact, making installation and maintenance quite easy. The storage tank of a thermo-siphon system is usually applied right above the collector on the rooftop and directly exposed to the seasons. These systems are typical in warm climates, due to their lower efficiency compared with forced circulation systems. The most common problems are heat losses and the risk of freezing; they are therefore not suitable for areas where temperatures drop below freezing. In southern Europe, a system like this is capable of providing almost the total hot water demand of a household. However, the largest market for thermo-siphon systems is China. In Europe, thermo-siphon solar hot water systems are 95% of private installations in Greece<sup>56</sup>, followed by 25% and 15% of newly installed systems in Italy and Spain newly in 2009.<sup>57</sup>

FIGURE 10.30 | NATURAL FLOW SYSTEMS VS. FORCED CIRCULATION SYSTEMS



source EPIA.

#### REFERENCES

<sup>55</sup> WEISS, W., ET AL. (2009): PROCESS HEAT COLLECTORS - STATE OF THE ART. IEA HEATING AND COOLING PROGRAMME AND IEA SOLARPACES PROGRAMME, 2008. INTERNATIONAL ENERGY AGENCY (IEA), PARIS, FRANCE.

<sup>56</sup> TRAVASAROS, C. (2011): THE GREEK SOLAR THERMAL MARKET AND INDUSTRIAL APPLICATIONS - OVERVIEW OF THE MARKET SITUATION. GREEK SOLAR INDUSTRY ASSOCIATION, WORLD SUSTAINABLE ENERGY DAYS 2011, WELS, 3.3.2011, [HTTP://WWW.WSED.AT/FILEADMIN/REDAKTEURE/WSED/2011/DOWNLOAD\\_PRESENTATIONS/TRAVASAROS.PDF](http://www.wsed.at/fileadmin/redakteure/wsed/2011/download_presentations/travasaros.pdf).  
<sup>57</sup> WEISS, W. ET AL. (2011): SOLAR HEAT WORLDWIDE - MARKETS AND CONTRIBUTION TO THE ENERGY SUPPLY 2009. IEA SOLAR HEATING AND COOLING PROGRAMME, MAY 2011. INTERNATIONAL ENERGY AGENCY (IEA), PARIS, FRANCE.

## PUMPED SYSTEMS

The majority of systems installed in Europe are forced circulation (pumped) systems, which are far more complex and expensive than thermosiphon systems. Typically, the storage tank is situated inside the house (for instance in the cellar). An automatic control pump circulates the water between the storage tank and the collector. Forced circulation systems are normally installed with a heat exchanger, which means they have two circuits. They are mostly used in areas with low outside temperatures, and antifreeze additives might have to be added to the solar circuit to protect the water from freezing and destroying the collector.

Even though forced circulation systems are more efficient than thermosiphon systems, they are mostly not capable of supplying the full hot water demand in cold areas and are usually combined with a back-up system, such as heat pumps, pellet heaters or conventional gas or oil boilers. The solar coverage of a system is the share of energy provided by the solar system in relation to total heat consumption, such as space heating or hot water. Solar coverage levels depend on the heat demand, the outside temperature and the system design. For hot water production, a solar coverage of 60% in central Europe is common at the current state of technology development. The typical collector area installed for a domestic hot water system in a single family house in the EU 27 is 3-6 m<sup>2</sup>. For multifamily houses and hotels, the size of installations is much bigger, with a typical size of 50 m<sup>2</sup>.<sup>58,59,60</sup>

**Domestic heat systems**

Besides domestic hot water systems, solar thermal energy for space heating systems is becoming increasingly relevant in European countries. In fact, the EU 28 is the largest market for this application at the moment, with Germany and Austria as the main driving forces. The collectors used for these applications are, however, the same as for domestic hot water systems for solar space heating purposes, though only pumped systems are suitable. Effectively most systems used are so called combi-systems that provide space as well as water heating.

So far, most installations are built on single-family houses with a typical system size between 6 and 16 m<sup>2</sup> and a typical annual solar coverage of 25 % in central Europe.<sup>58,59,60</sup>

Solar combi-systems for multiple family houses are not yet used very frequently. These systems are about 50 m<sup>2</sup>, cost approximately 470-550 €/m<sup>2</sup> and have annual solar coverage of 25% in central Europe.<sup>58,59,60</sup> Large scale solar thermal applications connected to a local or district heating grids with a

collector area above 500 m<sup>2</sup> are not so common. However, since 1985, an increasing number of such systems have been installed per year in the EU with a typical annual solar coverage of 15 % in central Europe.<sup>58,59,60</sup> To get a significant solar share, large storage is needed. The typical solar coverage of such a system including storage is around 50 % today. With seasonal storage, the coverage may be increased to about 80 %.<sup>59</sup> Another option for domestic heating systems is air collector systems (not described here). The largest markets for air collectors are in North America and Asia; these systems have a very small penetration on the European market, though it has been increasing in recent years.

**Process heat**

Solar thermal use for industrial process heat is receiving some attention for development, although it is hardly in use today. Standardized systems are not available because industrial processes are often individually designed. Also, solar thermal applications are mostly not capable of providing 100 % of the heat required over a year, so another non-solar heat source would be necessary for commercial use.

Depending on the temperature level needed, different collectors have been developed to serve the requirements for process heat. Flat plates or evacuated tube collectors provide a temperature range up to 80 °C. A large number are available on the market. For temperatures between 80°C and 120°C advanced flat-plate collectors are available, such as with multiple glazing, antireflective coatings, evacuated tubes, and an inert gas filling. Other options are flat-plate and evacuated tube collectors with compound parabolic concentrators (CPC). These collectors can be stationary and are generally constructed to concentrate solar radiation by a factor of 1 to 2. They can use most diffuse radiation, which makes them especially attractive for areas with low direct solar radiation.

There are a few conceptual designs to reach higher temperatures between 80°C and 180°C, primarily using a parabolic trough or linear concentrating Fresnel collectors. These collector types have a higher concentration factor than CPC collectors, are only capable of using direct solar radiation, and have to be combined with sun tracking systems. The collectors especially designed for heat use are most suitable for a temperature range between 150°C and 250 °C.<sup>61</sup> Air collector systems for process heat are limited to lower temperatures, being mostly used for drying purposes (hay, etc.); they are not discussed here.

**Cooling**

Solar chillers use thermal energy to produce cooling and/or dehumidify the air in a similar way to a refrigerator or conventional air-conditioning. This application is well-suited to solar thermal energy, as the demand for cooling is often greatest when there is most sunshine. Solar cooling has been successfully demonstrated. Large-scale use can be expected in the future but is still not common.

## REFERENCES

- 58 WEISS, W. ET AL. (2011): SOLAR HEAT WORLDWIDE - MARKETS AND CONTRIBUTION TO THE ENERGY SUPPLY 2009. IEA SOLAR HEATING AND COOLING PROGRAMME, MAY 2011. INTERNATIONAL ENERGY AGENCY (IEA), PARIS, FRANCE.
- 59 NITSCH, J. ET AL. (2010): LEITSTUDIE 2010 - LANGFRISTZENZENARIEN UND STRATEGIEN FÜR DEN AUSBAU DER ERNEUERBAREN ENERGIEN IN DEUTSCHLAND BEI BERÜCKSICHTIGUNG DER ENTWICKLUNG IN EUROPA UND GLOBAL. STUTTGART, KASSEL, TELTOW, DEUTSCHES ZENTRUM FÜR LUFT- UND RAUMFAHRT, FRAUNHOFER INSTITUT FÜR WINDENERGIE UND ENERGIESYSTEMTECHNIK (IWES), INGENIEURBÜRO FÜR NEUE ENERGIEN (IFNE).
- 60 JAGER, D. ET AL. (2011): FINANCING RENEWABLE ENERGY IN THE EUROPEAN ENERGY MARKET. BRUSSELS, ECOFYS NL, FRAUNHOFER ISI, TU VIENNA EEG, ERNST & YOUNG, EUROPEAN COMMISSION (DG ENERGY).
- 61 WEISS, W., ET AL. (2008): PROCESS HEAT COLLECTORS - STATE OF THE ART. IEA HEATING AND COOLING PROGRAMME AND IEA SOLARPACES PROGRAMME, 2008. INTERNATIONAL ENERGY AGENCY (IEA), PARIS, FRANCE.

The option to use solar heat this way makes sense because hot regions require more cooling for comfort. Solar thermal cooling is mostly designed as a closed-loop sorption system (see Box 10.1). The most common application, however, is a solar absorption cooling unit. The system requires temperatures above 80°C, which means evacuated tube collectors, advanced flat-plate collectors and compound parabolic concentrators. The solar field required for a cooling unit is about 4 m<sup>2</sup> per kW of cooling capacity.

#### BOX 10.1 | SORPTION COOLING UNITS

A thermo-chemical refrigerant cycle (sorption) provides cold by either absorption or adsorption cooling. Absorption occurs when a gaseous or liquid substance is taken up by another substance, such as the solution of a gas in a liquid. Adsorption takes place when a liquid or gaseous substance is bound to the surface of a solid material.

The absorption cooling cycle can be described as follows: A liquid refrigerant with a very low boiling point is vaporized at low pressure, withdrawing heat from its environment and therefore providing the desired cooling. The gaseous refrigerant is then absorbed by a liquid solvent, mostly water. The refrigerant and solvent are separated again by adding (renewable) heat to the system, making use of the different boiling points. The gaseous refrigerant is now condensed, released and returned to the beginning of the process. The heat needed in the process can be provided by firing natural gas, combined heat and power plants, solar thermal collectors, etc.

#### 10.6.2 GEOTHERMAL, HYDROTHERMAL AND AERO-THERMAL ENERGY

The three categories of environmental heat are geothermal, hydrothermal and aero-thermal energy. Geothermal energy is the energy stored in the Earth's crust, i.e. in rock and subsurface fluids. The main source of geothermal energy is the internal heat flow from the Earth's mantle and core into the crust, which itself is replenished mainly by heat from the decay of radioactive isotopes. At depths of a few meters, the soil is also warmed by the atmosphere. Geothermal energy is available all year round, 24 hours a day, and is independent of climatic conditions. Hydrothermal energy is the energy stored in surface waters - rivers, lakes, and the sea. Hydrothermal energy is available permanently at temperature level similar to that of shallow geothermal energy. Aero-thermal energy is the thermal energy stored in the Earth's atmosphere, which originally comes from the sun, but has been buffered by the atmosphere. Aero-thermal energy is available uninterruptedly, albeit with variations in energy content due to climatic and regional differences.

#### Deep geothermal energy (geothermal reservoirs)

On average, the crust's temperature increases by 25-30°C per km, reaching around 100°C at 3 km depth in most regions of the world. High temperature fields with that reach over 180°C can be found at this depth in areas with volcanic activity. "Deep geothermal reservoirs" generally refer to geothermal reservoirs more than 400m deep, where reservoir temperatures typically exceed 50°C. Depending on reservoir temperature, deep geothermal energy is used to generate electricity and/or to supply hot water for various thermal applications, such as for district heat, balneology, etc. Temperatures in geothermal reservoirs less than 400m deep are typically below 30°C, which is too low for most direct use applications or electricity production. In these shallow fields, heat pumps are applied to increase the temperature level of the heat extracted from shallow geothermal reservoirs.

The use of geothermal energy for heating purposes or for the generation of electricity depends on the availability of steam or hot water as a heat transfer medium. In hydrothermal systems, hot water or water vapor can be tapped directly from the reservoir. Technologies to exploit hydrothermal systems are already well established and are in operation in many parts of the world. However, there is limited availability of aquifers with sufficient temperature and water production rate at favorable depths. In Europe, high temperature (above 180°C) hydrothermal reservoirs, generally containing steam, are found in Iceland and Italy.

Hydrothermal systems with aquifer lowers temperatures (below 180°C) can also be used to produce electricity and heat in other regions. They contain warm water or a water-steam mixture. In contrast to hydrothermal systems, EGS systems do not require a hot aquifer; the heat carrier is the rock itself. They can thus virtually be found everywhere. The natural permeability of these reservoirs generally does not allow a sufficient water flow from the injection to the production well, so energy projects require the artificial injection of water into the reservoir, which they do by fracturing rock underground. Water is injected from the surface into the reservoir, where the surrounding rock acts as a heat exchanger. The heated water is pumped back to the surface to supply a power plant or a heating network. While enhanced geothermal systems promise large potentials both for electricity generation and direct use, they are still in the pre-commercialization phase.

#### Direct use of geothermal energy

(Deep) geothermal heat from aquifers and deep reservoirs can be used directly in hydrothermal heating plants to supply heat demand nearby or in a district heating network. Networks provide space heat, hot water in households and health facilities or low temperature process heat (industry, agriculture and services). In the surface unit, hot water from the production well is either directly fed into a heat distribution network ("open loop system"), or heat is

transferred from the geothermal fluid to a secondary heat distribution network via heat exchangers (“closed loop system”). Heating network temperatures are typically in the range 60-100°C. However, higher temperatures are possible if wet or dry steam reservoirs are exploited or if heat pumps are switched into the heat distribution circuit. In these cases, geothermal energy may also supply process heat applications requiring temperatures above 100°C.

Direct use provides heating and cooling for buildings including district heating, fish ponds, greenhouses, bathing, wellness and swimming pools, water purification/desalination, and industrial and process heat for agricultural products and mineral extraction and drying (IPCC-SRREN 2012).<sup>62</sup>

For space heating, two basic types of systems are used: open and closed loops. Open loop (single pipe) systems directly utilize the geothermal water extracted from a well to circulate through radiators (Figure 10.31, top). Closed loop (double pipe) systems use heat exchangers to transfer heat from the geothermal water to a closed loop that circulates heated freshwater through the radiators (Figure 10.31; bottom).

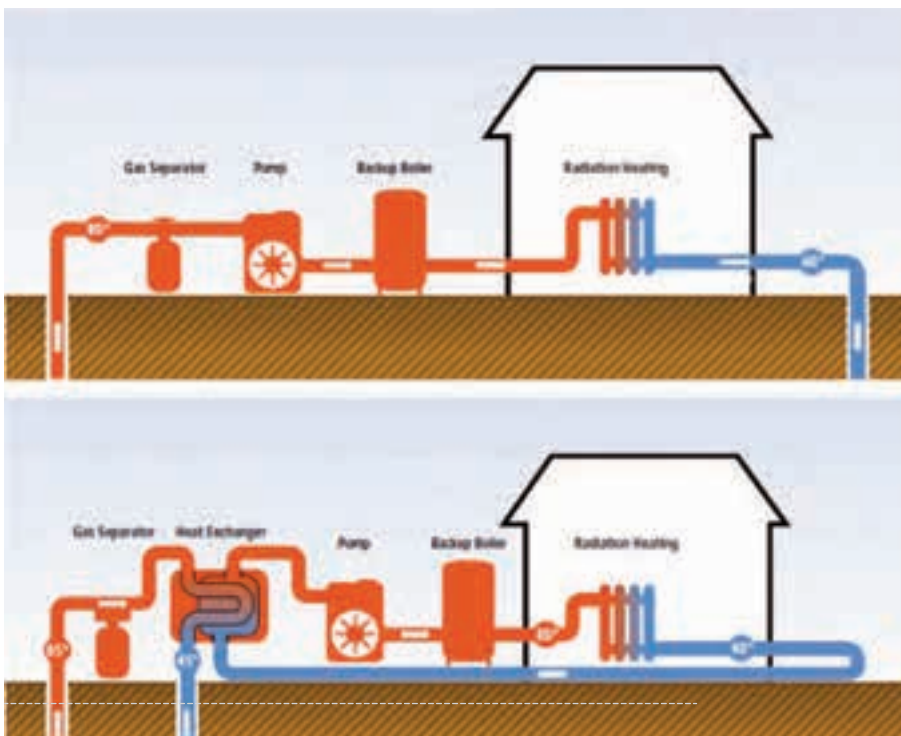
Alternatively, deep borehole heat exchangers can exploit the relatively high temperature at depths between 300 and

3,000 m (20 – 110°C). Heat pumps can be used to increase the temperature of the useful heat, if required. The overall efficiency of geothermal heat use can be raised if several thermal direct-use applications with successive lower temperature levels are connected in series (cascades). For example, dry steam at 250°C can be fed to a cogeneration plant for electricity, the co-generated heat then fed into a district heating network at 80°C, and the waste heat at 40°C used to warm fishing ponds. The main costs for deep geothermal projects are in drilling.

### Simultaneous production of electricity and heat

In many cases, geothermal power plants also produce heat to supply a district heating network. There are two different options for using heat: one where the geothermal fluid is separated into two streams separately used either for power production or to feed the heat network; or a heat exchanger transfers thermal energy from the geothermal fluid to the working fluid, which feeds the turbines. After the heat exchange process, the leftover heat from the geothermal fluid can be used for heating purposes. In both cases, after the electricity production in the turbines waste heat is not captured as it is for cogeneration (CHP), but released into the environment.

**FIGURE 10.31 | TWO MAIN TYPES OF DISTRICT HEATING SYSTEMS: TOP, OPEN LOOP (SINGLE PIPE SYSTEM), BOTTOM, CLOSED LOOP (DOUBLE PIPE SYSTEM)**



source IPCC 2012: Special Report on Renewable Energy Sources and Climate Change Mitigation. Prepared by Working Group III of the Intergovernmental Panel on Climate Change, Cambridge University Press.

### REFERENCES

62 IPCC 2012: SPECIAL REPORT ON RENEWABLE ENERGY SOURCES AND CLIMATE CHANGE MITIGATION.

### 10.6.3 HEAT PUMP TECHNOLOGY

A heat pump is a device that transfers heat from one fluid at a lower temperature to another at a higher temperature. Thus, it allows heat to be carried from a lower to a higher temperature level. The function of the heat pump may therefore be compared to that of a water pump positioned between two water basins connected to each other but located at different altitudes: water will naturally flow from the higher to the lower basin. It is, however, possible to return water to the higher basin by using a pump, which draws water from the lower one.

A heat pump consists of a closed circuit through which a special fluid (refrigerant) flows. This fluid takes on a liquid or gaseous state according to temperature and pressure conditions. The condenser and the evaporator consist of heat exchangers, i.e. special tubes placed in contact with service fluids (such as air) in which the refrigerant flows. The latter transfer heat to the condenser (the high temperature side) and takes it away from the evaporator (the low temperature side). Electric power is required to operate heat pumps, making them an efficient way of electric heating.

Heat pumps have become increasingly important in buildings but can also be used for industrial process heat. Industrial heat pumps (IHPs) offer various opportunities to all types of manufacturing processes and operations and use waste process heat as the heat source, deliver heat at higher temperature for use in industrial processes, heating or preheating, or for space heating and cooling in industry. The introduction of heat pumps with operating temperature below 100 °C are state of the art technologies while higher temperature applications still require additional R&D activities.<sup>54</sup>

Heat pumps use the refrigeration cycle to provide heating, cooling and sanitary hot water. They employ renewable energy from ground, water and air to move heat from a relatively low temperature reservoir (the “source”) to the temperature level of the desired thermal application (the “output”). Heat pumps commonly use two types of refrigeration cycles:

- Compression heat pumps use mechanical energy, most commonly electric motors or combustion engines to drive the compressor in the unit. Consequently, electricity, gas or oil is used as auxiliary energy.
- Thermally driven heat pumps use thermal energy to drive the sorption process - either adsorption or absorption - to make ambient heat useful. Different energy sources can be used as auxiliary energy: waste energy, biomass, solar thermal energy or conventional fuels.

Compression heat pumps are most commonly used today; however, thermally driven units are seen as a promising future technology. The “efficiency” of a heat pump is described by the coefficient of power (COP) - the ratio between the annual useful heat output and the annual auxiliary energy

consumption of the unit. In the residential market, heat pumps work best for relatively warm heat sources and low-temperature applications such as space heating and sanitary hot water. They are less efficient for providing higher temperature heat and can’t be used for heat over 90°C. For industrial applications, different refrigerants can be used to provide heat from 80°C to 90°C efficiently, so they are only suitable for part of the energy requirements of industry.

**Heat pumps are generally distinguished by the heat source they exploit:**

- Ground source heat pumps use the energy stored in the ground at depths from around hundred meters up to the surface. They are used for deep borehole heat exchangers (300 – 3,000m), shallow borehole heat exchangers (50-250m) and horizontal borehole heat exchangers (a few meters deep).
- Water source heat pumps are coupled to a (relatively warm) water reservoir of around 10°C, such as wells, ponds, rivers, and the sea.
- Aero-thermal heat pumps use the outside air as heat source. As outside temperatures during the heating period are generally lower than soil and water temperature, ground source and water source heat pumps typically more efficient than aero-thermal heat pumps.

Heat pumps require additional energy apart from the environmental heat extracted from the heat source, so the environmental benefit of heat pumps depends on both their efficiency and the emissions related to the production of the working energy. Where the heat pump has low COP and a high share of electricity from coal power plants, for example, carbon dioxide emissions relative to useful heat production might be higher than conventional gas condensing boilers. On the other hand, efficient heat pumps powered with “green” electricity are 100% emission-free solutions that contribute significantly to the reduction of greenhouse gas emissions when used in place of fossil-fuel fired heating systems.

#### BOX 10.2 | TYPICAL HEAT PUMP SPECIFICATIONS

Usually provide hot water or space heat at lower temperatures, around 35°C.

Example uses: underfloor/wall heating.

Typical size for space heating a single family house purposes: approx. 5-10 kW thermal

Typical size for space heating a large office building: >100 kW thermal.

Aero-thermal heat pumps do not require drilling, which significantly reduces system costs compared to other types.

If waste heat from fossil fuel fired processes is used as heat source for this technology, the heat provided cannot be classified as “renewable” - it becomes merely an efficient way of making better use of energy otherwise wasted.

#### REFERENCES

63 (IEA-ETN 2014) APPLICATION OF INDUSTRIAL HEAT PUMPS; FINAL REPORT; IEA HEAT PUMP CENTRE; BORÅS; SWEDEN; 2014.



**Heat pumps for cooling**

Reversible heat pumps can be operated both in heating and in cooling mode. When running in cooling mode in summer, heat is extracted from the building and “pumped” into the underground reservoir, which is then heated. In this way, the temperature of the warm reservoir in the ground is restored after its exploitation in winter.

Alternatively, renewable cooling could be provided by circulating a cooling fluid through the relatively cool ground

before being distributed in a building’s heating/cooling system (“free cooling”). However, this cooling fluid must not be based on chemicals that are damaging to the upper atmosphere, such as HFCs (a strong greenhouse gas) or CFCs (ozone-depleting gas).

In principle, high enthalpy geothermal heat might provide the energy needed to drive an absorption chiller. However, only a very limited number of geothermal absorption chillers are in operation world-wide.

**BOX 10.3 | DISTRICT HEAT NETWORKS**

Heat networks are preferably used in populated areas such as large cities. Their advantages include a reduction of local emissions, higher efficiency (in particular with cogeneration), and less need for infrastructures that go along with individual heating solutions. Generally heat from all sources can be used in heat networks. However, some applications like cogeneration technologies have a special need for a secure heat demand provided by heat networks to be able to operate economically.

Managing the variations in heat supply and demand is vital for high shares of renewables, which is more challenging for space heat and hot water than for electricity. Heat networks help even out peaks in demand by connecting a large number of clients, and supply can be adjusted by tapping various renewable sources and relatively cheap storage options. The use of an existing heat network for renewable heat depends on the

competitiveness of the new heat applications or plants. The development of new networks, however, is not an easy task.

The factors to assess whether a new heat network is economically competitive compared to other heating and cooling options are:

- Heat density (heat demand per area) of building infrastructure, depending on housing density and the specific heat demand of the buildings
- Obligation to connect to the network (leads to higher effective heat density)
- Existing building infrastructure and newly developed areas, where network installation can be integrated in building site preparation
- Existence of competing infrastructures such as gas networks
- Size of the heat network and distance to the remotest client

**FIGURE 10.32 | EXAMPLES FOR HEAT PUMP SYSTEMS.** LEFT: AIR SOURCE HEAT PUMP, MIDDLE: GROUND SOURCE HEAT PUMP WITH HORIZONTAL COLLECTOR, RIGHT: WATER SOURCE HEAT PUMP (OPEN LOOP SYSTEM WITH TWO WELLS)



source GERMAN HEAT PUMP ASSOCIATION (BWP).

#### 10.6.4 BIOMASS HEATING TECHNOLOGIES

There is a broad portfolio of technologies for heat production available from biomass, a traditional fuel source. A need for more sustainable energy supply has led to the development of modern biomass technologies. A high variety of new or modernised technologies and technology combinations can serve space and hot water needs and eventually also provide process heat even for industrial processes.

Biomass can provide a large temperature range of heat and can be transported over long distances, which is an advantage compared to solar thermal or geothermal heat. However, sustainable biomass imposes limits on volume and transport distance. Another drawback of bioenergy is exhaust emissions and the risk of greenhouse gas emissions from energy crop cultivation.

These facts lead to two approaches to biomass development:

- Towards improved, relatively small-scale, decentralized systems for space heat and hot water.
- Development of various highly efficient and upgraded biomass cogeneration systems for industry and district heating.

##### Small applications for space heat and hot water in buildings

In the residential sector, traditional biomass applications have been strongly improved over the last decades for efficient and comfortable space heating and hot water supply. The standard application is direct combustion of solid biomass (wood), for example in familiar but improved firewood stoves for single rooms. For average single homes and small apartment houses, firewood and pellet boilers are an option to provide space heat and hot water. Wood is easy to handle, and standardized quality and pellet systems can be automated along the whole chain; refuelling can then be reduced to a few times a year. Automatically fed systems are more easily adaptable to variations in heat demand, such as between summer and winter. Another advantage is lower emissions of air pollutants from pellet appliances compared to firewood.<sup>64</sup> Pellet heating systems are gaining importance in Europe.

Handfed systems are common for smaller applications below 50 kW. Small applications for single rooms (around 5kW capacity) are usually handfed wood stoves with rather low efficiency and low cost. Technologies are available for central heating in single and semi-detached houses and are also an option for apartment complexes. Wood boilers provide better combustion with operating efficiencies of 70-85% and fewer emissions than stoves with a typical sizes of 10-50 kW.<sup>65,66,67</sup>

##### REFERENCES

- 64 GEMIS (2011): GLOBALES EMISSIONS-MODELL INTEGRIERTER SYSTEME (GEMIS), VERSION 4.6, ÖKO-INSTITUT.  
 65 NITSCH, J. ET AL. (2010): LEITSTUDIE 2010 - LANGFRISTSZENARIEN UND STRATEGIEN FÜR DEN AUSBAU DER ERNEUERBAREN ENERGIEN IN DEUTSCHLAND BEI BERÜCKSICHTIGUNG DER ENTWICKLUNG IN EUROPA UND GLOBAL. STUTTGART, KASSEL, Teltow, DEUTSCHES ZENTRUM FÜR LUFT- UND RAUMFAHRT, FRAUNHOFER INSTITUT FÜR WINDENERGIE UND ENERGIESYSTEMTECHNIK (IWES), INGENIEURBÜRO FÜR NEUE ENERGIEN (IFNE).  
 66 GEMIS (2011): GLOBALES EMISSIONS-MODELL INTEGRIERTER SYSTEME (GEMIS), VERSION 4.6, ÖKO-INSTITUT.  
 67 AEBIOM (2011B): REVIEW OF INVESTMENT COST DATA FOR BIOMASS HEATING TECHNOLOGIES. G. A. CENTER, BRUSSELS.  
 68 KALTSCHMITT, M. ET AL., EDS. (2009): ENERGIE AUS BIOMASSE - GRUNDLAGEN, TECHNIKEN UND VERFAHREN. BERLIN, HEIDELBERG, SPRINGER.  
 69 IEA (2011B): COGENERATION AND RENEWABLES. INTERNATIONAL ENERGY AGENCY (IEA), PARIS, FRANCE.  
 70 KALTSCHMITT, M. ET AL., EDS. (2009): ENERGIE AUS BIOMASSE - GRUNDLAGEN, TECHNIKEN UND VERFAHREN. BERLIN, HEIDELBERG, SPRINGER.

Larger wood boilers can heat large buildings such as apartment blocks, office buildings and other large buildings in service, commerce and industry with space heat and hot water.

##### Direct heating technologies

Large applications for district or process heat rely on automatic feeding technologies, due to constant heat demand at a defined temperature. Direct combustion of biomass can provide temperatures up to 1,000°C, with higher temperatures from wood and lower temperatures from straw, for instance. Automatically fed systems are available for wood chips, pellets, and straw. Three combustion types are:<sup>68</sup>

##### COGENERATION TECHNOLOGIES

Cogeneration increases the efficiency of using biomass, if the provided heat can be used efficiently. The size of a plant is limited due to the lower energy content of biomass compared to fossil fuels and resulting difficulties in fuel logistics. Selection of the appropriate cogeneration technology depends on the available biomass. In several Scandinavian countries – with an extraordinarily high potential of forest biomass - solid biomass is already a main fuel for cogeneration processes. Finland gets more than 30% and Sweden even 70% of its co-generated electricity from biomass.<sup>69</sup>

##### DIRECT COMBUSTION TECHNOLOGIES

The cogeneration processes can be based on direct combustion types (fixed bed combustion, fluidised bed combustion, pulverised fuel combustion). While steam engines are available from 50 kW electric steam turbines normally cover the range above 2 MW<sub>el</sub>, with special applications available from 0.5 MW electric. The heat is typically generated at 60- 70% efficiency depending on the efficiency of the power production process, which in total can add up to 90%.<sup>70</sup> Thus, small and medium cogeneration plants provide three to five times more heat than power, with local heat demand often being the limiting factor for the plant size.

##### UPGRADED BIOMASS

There are various conversion technologies available to upgrade biomass products for the use in specific applications and for higher temperatures. Common currently available technologies are (upgraded) biogas production and gasification. Other technologies such as pyrolysis and the production of synthetic gases and oils are under development.

Gasification is especially valuable in the case of biomass with low caloric value and when it includes moisture. Partial oxidation of the biomass fuel provides a combustible gas mixture mainly consisting of carbon monoxide (CO). Gasification can provide higher efficiency along the whole biomass chain, but at the expense of additional investments in this more sophisticated technology. There are many different gasification systems based on varying fuel input, gasification technology and combination with gas turbines. The literature shows a large cost range for gasification cogeneration plants. Assumptions on costs of the gasification processes vary strongly.

Other upgrading processes are biogas upgrading for exports of natural gas network and the production of liquid biomass, such as plant oil, ethanol or second generation fuels. Those technologies can be easily exchangeable with fossil fuels, but the low efficiency of the overall process and energy input needed to produce energy crops are disadvantages for sustainability.

### 10.6.5 BIOGAS

Biogas plants use anaerobic digestion of bacteria for the conversion of various biomass substrates into biogas. This gas mainly consists of methane (a gas of high caloric value), CO<sub>2</sub>, and water. Anaerobic digestion can be used to upgrade organic matter with low energy density, such as organic waste and manure. These substrates usually contain large water contents and appear liquid. "Dry" substrates need additional water.

Liquid residues like wastes and excrements are energetically unused. Biogas taps into their calorific potential. The residue of the digestion process is used as a fertilizer, which has higher availability of nitrogen and is more valuable than the input substrates.<sup>71</sup>

Methane is a strong greenhouse gas, so biogas plants need airtight covers for the digestate to maintain low emissions.<sup>72</sup> Residues and wastes are preferable for biogas compared with energy crops such as corn silage, which require energy and fertilizer inputs while growing and thus create greenhouse gas emissions.

Biogas plants usually consist of a digester for biogas production and a cogeneration plant. Plants vary in size and are normally fed by a mixture of substrates for example manure mixed with maize silage, grass silage, other energy crops and/or organic waste.<sup>73</sup>

Normally biogas is normally used in cogeneration. In Germany, the feed-in tariff means biogas production currently is mostly for power. The majority of biogas plants are on farms in rural areas. Small biogas plants often use the produced heat for local space heating and process heat, such as for drying processes. Larger biogas plants need access to a heat network to make good use of all the available heat. However, network access is often not available in rural areas, so there is still untapped potential of heat consumption from biogas. Monitoring of German biogas plants showed that 50% of available heat was actually wasted.<sup>74</sup> The conditioning and enriching of biogas and subsequent export to the gas network has been promoted lately and should become an option to use biogas directly at the location of heat demand.

Upgrading technologies for biomass do bear the risk of additional methane emissions, so tight emission standards are necessary to achieve real reductions in greenhouse gas emissions.<sup>75</sup>

**Greenpeace has a very strict policy in order to use only sustainable bioenergy in future energy systems. Guidelines for the future use of bioenergy are documented in Chapter 8**

### 10.6.6 STORAGE TECHNOLOGIES

As the share of electricity provided by renewable sources increases around the world the technologies and policies required to handle their variability is also advancing. Along with the grid-related and forecasting solutions discussed in Chapter 3, energy storage is a key part of the Energy [R]evolution.

Once the share of electricity from variable renewable sources exceeds 30-35%, energy storage is necessary in order to compensate for generation shortages or to store possible surplus electricity generated during windy and sunny periods. Today storage technology is available for different stages of development, scales of projects, and for meeting both short- and long-term energy storage needs. Short-term storage technologies can compensate for output fluctuations that last only a few hours, whereas longer term or seasonal storage technologies can bridge the gap over several weeks.

Short-term options include batteries, flywheels, compressed air power plants and pump storage power stations with high efficiency factors. The later is also used for long term storage. Perhaps the most promising of these options is electric vehicles (EVs) with Vehicle-to-Grid (V2G) capability, which can increase flexibility of the power system by charging when there is surplus renewable generation and discharging while parked to take up peaking capacity or ancillary services to the power system. Vehicles are often parked close to main load centres during peak times (e.g., outside factories) so there would be no network issues. However battery costs are currently very high and significant logistical challenges remain.

Seasonal storage technologies include hydro pumped storage and the production of hydrogen or renewable methane. While the latter two options are currently in the development with several demonstration projects mainly in Germany, pumped storage has been in use around the world for more than a century.

#### REFERENCES

- 71 KALTSCHMITT, M. ET AL., EDS. (2009): ENERGIE AUS BIOMASSE - GRUNDLAGEN, TECHNIKEN UND VERFAHREN. BERLIN, HEIDELBERG, SPRINGER.
- 72 PEHNT, M. ET AL. (2007): BIOMASSE UND EFFIZIENZ - VORSCHLÄGE ZUR ERHÖHUNG DER ENERGIEEFFIZIENZ VON §8 UND §7-ANLAGEN IM ERNEUERBARE-ENERGIEN-GESETZ. ARBEITSPAPIER NR. 1 IM RAHMEN DES PROJEKTES "ENERGIEBALANCE - OPTIMALE SYSTEMLÖSUNGEN FÜR ERNEUERBARE ENERGIEN UND ENERGIEEFFIZIENZ". HEIDELBERG, INSTITUT FÜR ENERGIE UND UMWELTFORSCHUNG HEIDELBERG GMBH (IFEU).
- 73 IEA (2007): RENEWABLES FOR HEATING AND COOLING. INTERNATIONAL ENERGY AGENCY (IEA), PARIS, FRANCE. NITSCH, J. ET AL. (2010): LEITSTUDIE 2010 - LANGFRISTSZENARIEN UND STRATEGIEN FÜR DEN AUSBAU DER ERNEUERBAREN ENERGIEN IN DEUTSCHLAND BEI BERÜCKSICHTIGUNG DER ENTWICKLUNG IN EUROPA UND GLOBAL. STUTTGART, KASSEL, Teltow, DEUTSCHES ZENTRUM FÜR LUFT- UND RAUMFAHRT, FRAUNHOFER INSTITUT FÜR WINDENERGIE UND ENERGIESYSTEMTECHNIK (IWES), INGENIEURBÜRO FÜR NEUE ENERGIEN (IFNE).
- 74 DBFZ (2010): MONITORING ZUR WIRKUNG DES ERNEUERBARE-ENERGIEN-GESETZES (EEG) AUF DIE ENTWICKLUNG DER STROMERZEUGUNG AUS BIOMASSE (UNVERÖFFENTLICHTER ENTWURF). LEIPZIG, DEUTSCHES BIOMASSEFORSCHUNGSZENTRUM.
- 75 GÄRTNER, S. ET AL. (2008): OPTIMIERUNGEN FÜR EINEN NACHHALTIGEN AUSBAU DER BIOGASERZEUGUNG UND -NUTZUNG IN DEUTSCHLAND, MATERIALBAND E: ÖKOBILANZEN. HEIDELBERG, INSTITUT FÜR ENERGIE- UND UMWELTFORSCHUNG.

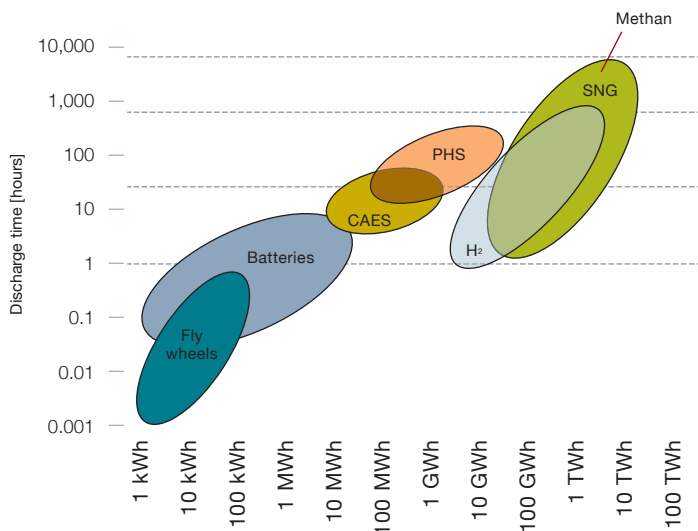
### Pumped Storage

Pumped storage is the largest-capacity form of grid energy storage now available and currently the most important technology to manage high shares of wind and solar electricity. It is a type of hydroelectric power generation that stores energy by pumping water from a lower elevation reservoir to a higher elevation during times of low-cost, off-peak electricity and releasing it through turbines during high demand periods. While pumped storage is currently the most cost-effective means of storing large amounts of electrical energy on an operating basis, capital costs and appropriate geography are critical decision factors in building new infrastructure. Losses associated with the pumping and water storage process make such plants net consumers of energy; accounting for evaporation and conversion losses, approximately 70-85% of the electrical energy used to pump water into the elevated reservoir can be recaptured when it is released.

### Renewable Methane

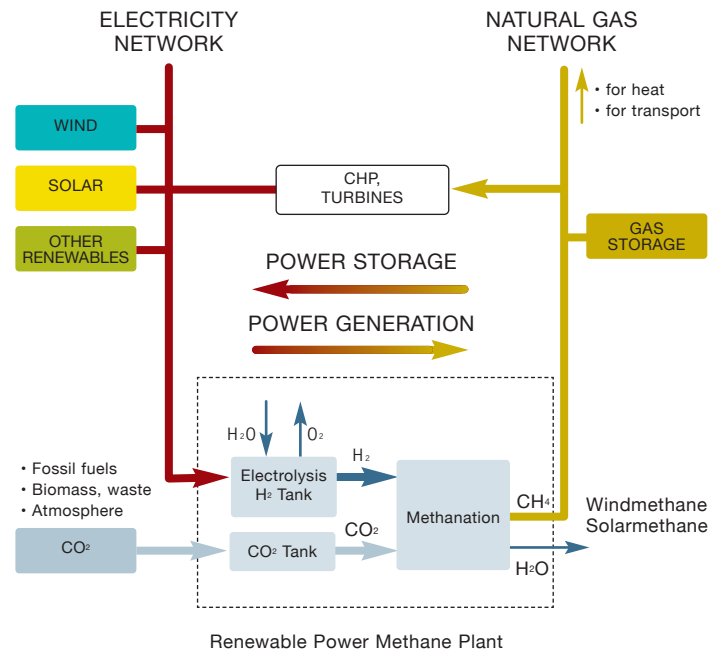
Both gas plants and cogeneration units can be converted to operate on renewable methane, which can be made from renewable electricity and used to effectively store energy from the sun and wind. Renewable methane can be stored and transported via existing natural gas infrastructure, and can supply electricity when needed. Gas storage capacities can close electricity supply gaps of up to two months, and the smart link between power grid and gas network can allow for grid stabilisation. Expanding local heat networks, in connection with power grids or gas networks, would enable the electricity stored as methane to be used in cogeneration units with high overall efficiency factors, providing both heat and power.<sup>76</sup> There are currently several pilot projects in Germany in the range of one to two- Megawatt size, but not in a larger commercial scale yet. If those pilot projects are successful, a commercial scale can be expected between 2015 and 2020. However, policy support, to encourage the commercialisation of storage is still lacking.

**FIGURE 10.33 | OVERVIEW STORAGE CAPACITY OF DIFFERENT ENERGY STORAGE SYSTEMS**



source Fraunhofer Institut, 2010.

**FIGURE 10.34 | RENEWABLE (POWER) (TO) METHANE - RENEWABLE GAS** STORING RENEWABLE POWER AS RENEWABLE AS NATURAL GAS BY LINKING ELECTRICITY AND NATURAL GAS NETWORKS



### REFERENCES

<sup>76</sup> (F-IWS 2010) FRAUNHOFER IWS, ERNEUERBARES METHAN KOPPLUNG VON STROM- UND GASNETZ M.SC. MAREIKE JENTSCH, DR. MICHAEL STERNER (IWS), DR. MICHAEL SPECHT (ZSW), TU CHEMNITZ, SPEICHERWORKSHOP CHEMNITZ, 28.10.2010.

## Battery Storage

There are numerous battery technologies on the market and the increasing demand for electric vehicles triggered the battery development significantly of the past decade. The latest announcement of the US American company TESLA to build up a large scale battery manufaction plant will most likely result in increased competition among the battery industry and reduced prices.

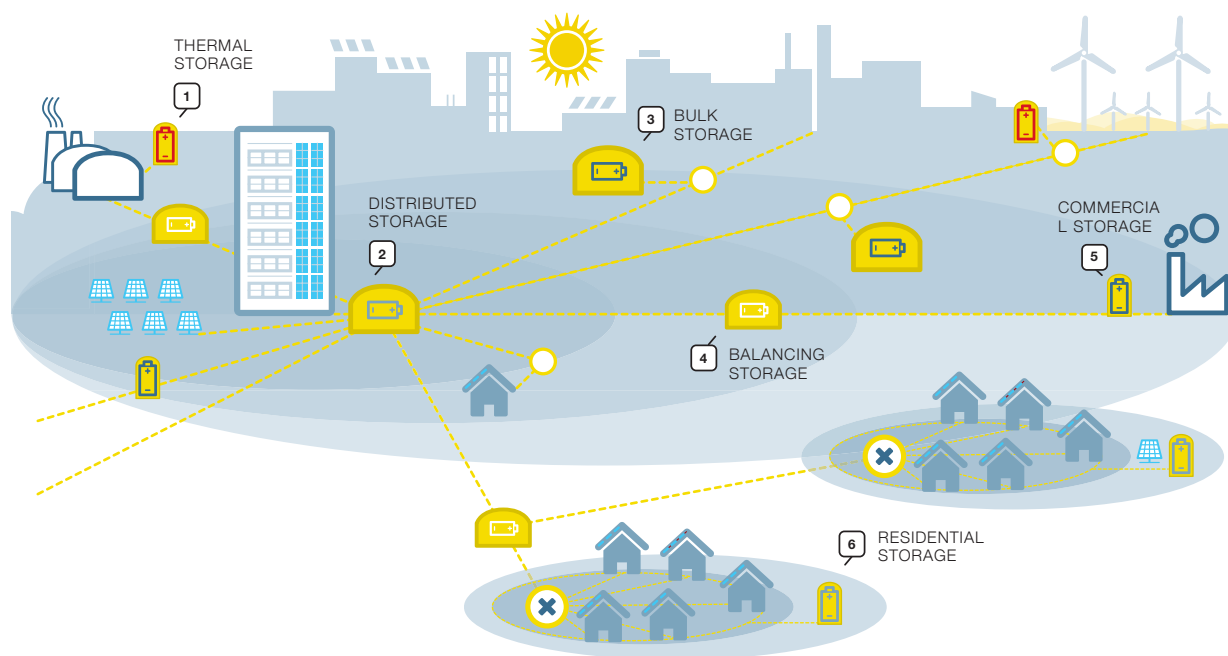
Especially lithium batteries are currently under discussion and a new generation of large scale Lithium-Metal and Lithium-Ion-Batteries (LIB) as well as small scale application such as TESLA's "PowerWall" will increasingly complement renewable power generation. Besides that, mobile energy storage devices form the basis not only for future oriented drive systems such as vehicles with hybrid drive and all electrically driven vehicles but also hydrogen storage and fuel cell technologies. Battery systems like lithium-sulfur and lithium-air have a great potential to reach the highest capacity and energy density values (DLR-Wagner).<sup>77</sup> In order to increase battery safety, reliability and to reduce costs partly through

economies of scale, battery research and development activities have significantly expanded worldwide. Many energy experts see new battery technology in combination with low cost solar photovoltaic power generation as a potential disruptive technology which can change future energy markets dramatically.

## Storage technologies – the cascade approach

There is no "one-size-fits-all" technology for storage. Along the entire supply and demand chain, different storage technologies are required to cover the exact needs in regard to storage time – from second reserve for frequency stability to seasonal storage of several months. A cascade of different storage technologies is required to support the local integration of power generation from variable renewable energy (VRE) in distribution networks, support the grid infrastructure to balance VRE power generation, and support self-generation and self-consumption of VRE by customers. Figure 30 shows a whole range of storage technologies.

FIGURE 10.35 | POTENTIAL LOCATIONS AND APPLICATIONS OF ELECTRICITY STORAGE IN THE POWER SYSTEM



source IRENA – Storage 2015.<sup>78</sup>

## REFERENCES

- 77 (DLR-WAGNER 2015) DR. RER.NAT. NORBERT WAGNER; [HTTP://WWW.DLR.DE/TT/EN/DESKTOPDEFAULT.ASPX/TABID-7197/](http://www.dlr.de/TT/EN/DESKTOPDEFAULT.ASPX/TABID-7197/)  
 78 (IRENA – STORAGE 2015) RENEWABLES AND ELECTRICITY STORAGE – A TECHNOLOGY ROADMAP; INTERNATIONAL RENEWABLE ENERGY AGENCY (IRENA) IRENA INNOVATION AND TECHNOLOGY CENTRE; ROBER T-SCHUMAN-PLATZ 3; 53175 BONN; GERMANY; JUNE 2015

# ENERGY EFFICIENCY – MORE WITH LESS

METHODOLOGY FOR THE ENERGY DEMAND PROJECTIONS

ENERGY CONSUMPTION IN THE YEAR 2012

REFERENCE DEMAND SCENARIO  
EFFICIENCY MEASURES AND POTENTIALS

EFFICIENCY PATHWAYS OF THE ENERGY [R]EVOLUTION  
DEVELOPMENT OF ENERGY INTENSITIES



11

“  
smart use  
of renewable  
energy makes  
economic sense”

**IMAGE** THE DARK SQUARES THAT MAKE UP THE CHECKERBOARD PATTERN IN THIS IMAGE ARE FIELDS OF A SORT—FIELDS OF SEAWEED. ALONG THE SOUTH COAST OF SOUTH KOREA, SEAWEED IS OFTEN GROWN ON ROPES, WHICH ARE HELD NEAR THE SURFACE WITH BUOYS. THIS TECHNIQUE ENSURES THAT THE SEAWEED STAYS CLOSE ENOUGH TO THE SURFACE TO GET ENOUGH LIGHT DURING HIGH TIDE BUT DOESN'T SCRAPE AGAINST THE BOTTOM DURING LOW TIDE.

Using energy efficiently is cheaper than producing new energy from scratch and often has many other benefits. An efficient clothes washing machine or dishwasher, for example, uses less power and saves water too. Efficiency in buildings doesn't mean going without – it should provide a higher level of comfort. For example, a well-insulated house will feel warmer in the winter, cooler in the summer and be healthier to live in. An efficient refrigerator is quieter, has no frost inside or condensation outside, and will probably last longer. Efficient lighting offers more light where you need it. Efficiency is thus really better described as 'more with less'.

There are very simple steps every to efficiency both at home in business and industries, through updating or replacing separate systems or appliances, that will save both money and energy. But the biggest savings don't come from incremental steps but from rethinking the whole concept - 'the whole house', 'the whole car' or even 'the whole transport system'. In this way, energy needs can often be cut back by four to ten times.

In order to find out the global and regional energy efficiency potential, the Dutch Institute Ecofys developed energy demand scenarios for the Greenpeace Energy [R]evolution analysis in 2008, which have been updated by the University of Utrecht for the 2012 scenario edition (Graus et al. 2012).<sup>1</sup> For the 2015 edition, the German Aerospace Center (DLR) further developed and specified the energy demand pathways for the power, heating, industry, transport and other sectors via energy intensity indicators for all regions.

These scenarios cover energy demand over the period 2012-2050 for ten world regions. In contrast to a Reference scenario, based on the IEA World Energy Outlook 2014 (IEA WEO 2014)<sup>2</sup>, a low energy demand scenario for energy efficiency improvements has been defined taking into account historic trends, estimated technical efficiency potentials and regional differences. The efficiency scenario is based on the best technical energy efficiency potentials taking into account implementation constraints including costs and other barriers. The resulting demand structures of the updated Energy [R]evolution scenarios are summarised below. This chapter focuses on stationary sectors and processes, information about efficiency measures, technologies and demand scenarios for the transportation sector can be found in Chapter 12.

## 11.1 METHODOLOGY FOR THE ENERGY DEMAND PROJECTIONS

### 11.1.1 STEP 1: DEFINITION OF A REFERENCE DEMAND SCENARIO

In order to estimate potentials for energy-efficiency improvement in 2050 a detailed Reference scenario is required that projects the development of energy demand when current trends continue. In the World Energy Outlook 2014 "Current Policies" scenario (IEA WEO 2014) only currently adopted energy and climate change policies are implemented. Technological change including efficiency improvement is slow but substantial and mainly triggered by increased energy prices. The Reference scenario covers energy demand development in the period 2012-2050 for ten world regions and three sectors:

- Transport
- Industry
- Other (also referred to as "buildings and agriculture").

Within the industry and other sectors a distinction is made between electricity demand and fuel and heat demand. Heat demand mainly consists of district heating from heat plants and from combined heat and power plants. Fuel and heat demand is referred to as 'fuel demand' for in the figures that follow. The energy demand scenarios focus only on energy-related fuel, power and heat use. Feedstock consumption in industries is thus excluded from the analysis. Total final consumption data in WEO includes non-energy use. By assuming that the share of non-energy use remains the same as in the base year 2012, we determine the energy-related fuel use beyond 2012.

### 11.1.2 STEP 2: DEVELOPMENT OF LOW ENERGY DEMAND SCENARIOS

The low energy demand scenarios are based on literature studies and new calculations. The scenarios take into account:

- The implementation of best practice technologies and a certain share of emerging technologies.
- No behavioral changes or loss in comfort levels.
- No structural changes in the economy, other than occurring in the Reference scenario.
- Equipment and installations are replaced at the end of their (economic) lifetime, so no early retirement.

The development pathways are based on the current worldwide energy use per sector and subsector and the development of energy intensities in recent years, according to the WEO scenarios and under the assumption of technical potentials according to (Graus et al. 2012). Furthermore, the low energy demand scenarios aim for a convergence of

#### REFERENCES

- <sup>1</sup> (GRAUS ET AL. 2012); ENERGY DEMAND PROJECTIONS FOR ENERGY [R]EVOLUTION 2012; WINA GRAUS; KATERINA KERMEIJ; UTRECHT UNIVERSITY, MARCH 2012; COMMISSIONED BY: GREENPEACE INTERNATIONAL AND DLR; [HTTP://WWW.ENERGYBLUEPRINT.INFO/1432.0.HTML](http://www.energyblueprint.info/1432.0.html)
- <sup>2</sup> (IEA WEO 2014); WORLD ENERGY OUTLOOK 2014, INTERNATIONAL ENERGY AGENCY.

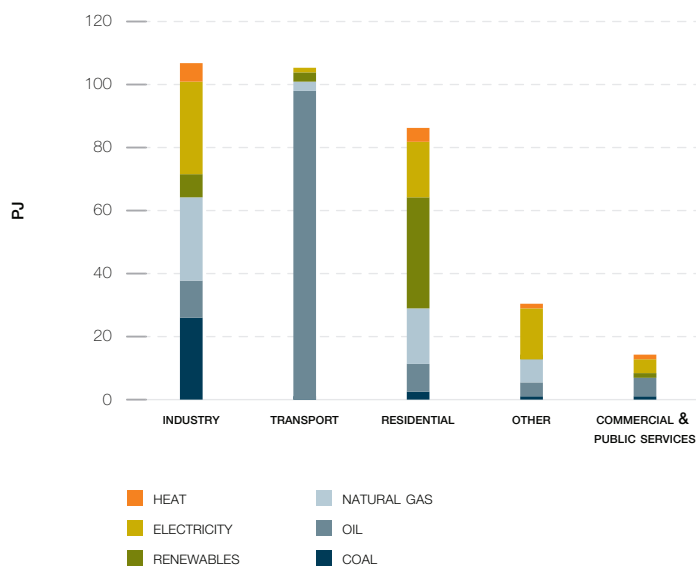
energy consumption pattern in the different world regions consistent to the convergence of economic development assumed in the scenarios. Figure 11.1 shows a breakdown of final energy demand in the world by the most important sub-sectors in the base year 2012.

Efficiency measures and potentials in the transport sector were described by the DLR Institute of Vehicle Concepts in 2012 and updated and expanded in 2014 in commission of Greenpeace (DLR 2015).<sup>3</sup> The results are used as a basis for developing the Energy [R]evolution scenarios and documented in Chapter 12.

## 11.2 ENERGY CONSUMPTION IN THE YEAR 2012

The following Figures provide a short overview on the energy consumption pattern worldwide and per world regions in 2012 as provided by the IEA Energy Balances of 2014.<sup>4</sup> Figure 11.1 shows the final energy consumption worldwide distinguished by energy carriers and sub-sectors.

**FIGURE 11.1 | FINAL ENERGY DEMAND FOR THE WORLD BY SUB SECTOR AND FUEL SOURCE IN 2012**



source IEA WEO 2014.

### REFERENCES

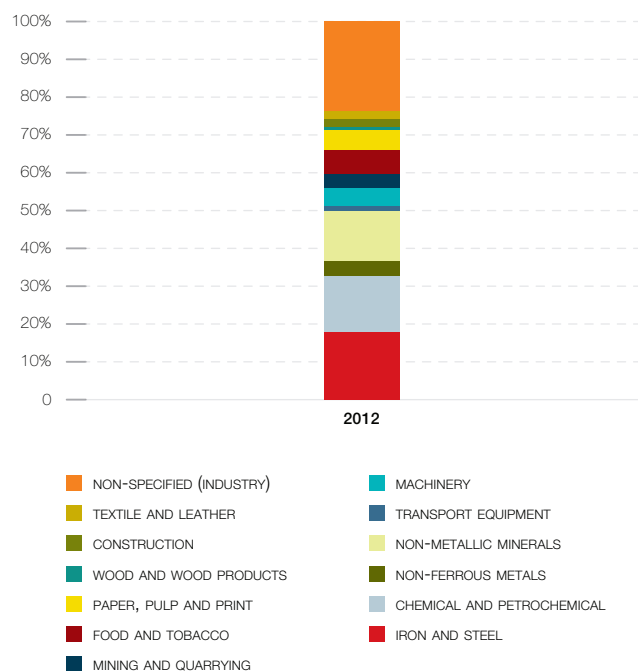
- 3 (DLR 2015); PROJECT REPORT; ALTERNATIVE TRANSPORT TECHNOLOGIES FOR MEGACITIES; GERMAN AEROSPACE CENTER (DLR), INSTITUTE OF VEHICLE CONCEPTS (DLR-FK), STUTTGART, GERMANY; 27 FEBRUARY 2015.  
4 (IEA 2014); INTERNATIONAL ENERGY AGENCY (IEA), PARIS; ENERGY BALANCES OF OECD COUNTRIES AND ENERGY BALANCES OF NON-OECD COUNTRIES, 2014 EDITION. [HTTP://DATA.IEA.ORG](http://data.iea.org)

Worldwide, industry consumes about 33% of total final energy demand on average in 2012 (excluding non-energy use). The share in Africa is lowest with 16%, the share in China is highest with 52%. Energy consumption in the Residential sector (included in Other sectors) add up to 25% of total final energy consumption worldwide.

Figure 11.2 shows a breakdown of final energy demand by sub sector in industry worldwide for the base year 2012.

The largest energy consuming sectors in industry are chemical and petrochemical industry, iron and steel and non-metallic minerals. Together the sectors consume about 45% of industrial energy demand. Since these three sectors are relatively large we look at them in detail. Also we look at aluminium production in detail, which is in the category of non-ferrous metals because the share of aluminium production makes up more than 10% of total industrial energy demand in 2012 (IEA-WEO 2014). For all sectors, we look at implementing best practice technologies, increased recycling and increased material efficiency. Where possible, the potentials are based on specific energy consumption data in physical units (MJ/tonne steel, MJ/tonne aluminium etc.).

**FIGURE 11.2 | BREAKDOWN OF FINAL ENERGY CONSUMPTION IN 2012 BY SUB SECTOR FOR INDUSTRY**



source IEA WEO 2014.

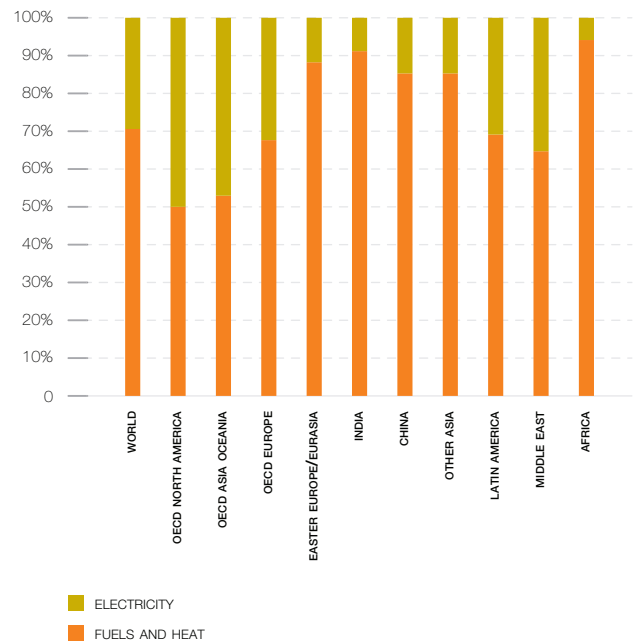


Energy consumed in buildings and agriculture (summarized as Other Sectors) represents 40% of global energy consumption in 2012. In most regions, the share of residential energy demand is larger than the share of commercial and public services energy demand (except in OECD Asia Oceania). Since energy use in agriculture is relatively small (globally less than 5% of total final energy demand), we do not look at this sector in detail but assume the same energy saving potentials as in residential and commercial combined.

Fuels and heat use represent the largest share of total final energy use in this sector, see Figure 11.4. The share ranges from 51% for OECD North America to 95% for Africa.

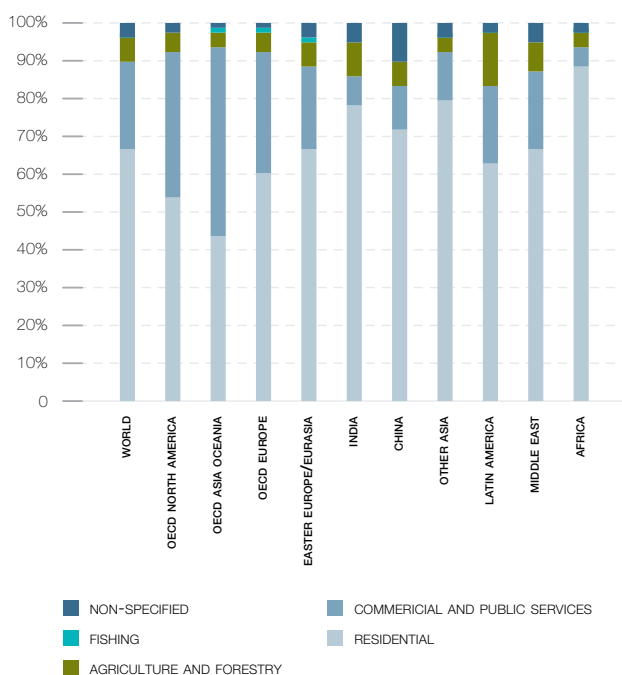
The residential sector has the largest end-use for fuels and heat, see Figure 11.5: Its share ranges from 44% in OECD Asia Oceania to 91% in Africa.

**FIGURE 11.4 | BREAKDOWN OF FINAL ENERGY DEMAND IN 2012 FOR ELECTRICITY AND FUELS/HEAT IN OTHER SECTORS**



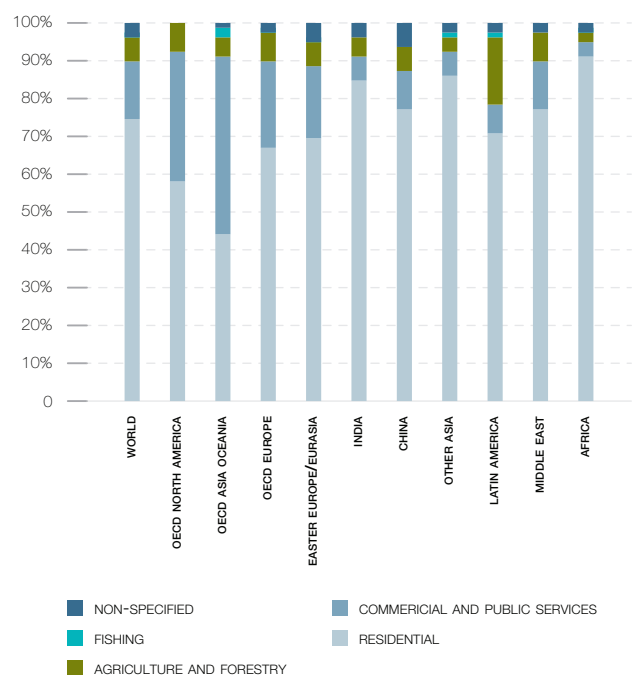
source IEA WEO 2014.

**FIGURE 11.3 | BREAKDOWN OF ELECTRICITY USE IN OTHER SECTORS IN 2012**



source IEA WEO 2014.

**FIGURE 11.5 | BREAKDOWN OF FUEL AND HEAT USE IN OTHER SECTORS IN 2012**



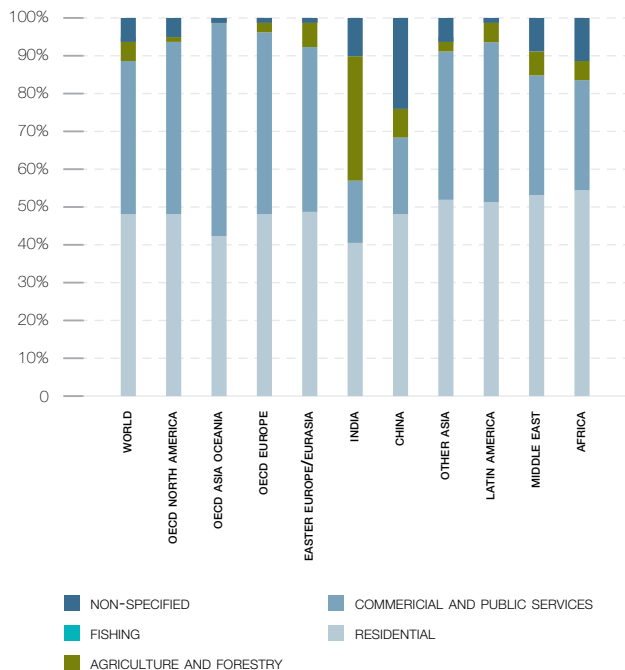
source IEA WEO 2014.

While residential buildings use a bigger share of fuel and heat, for electricity, the consumption is more evenly spread over the subsector of “commerce and public services” and residential. Globally, 48% of electricity is used in residential buildings and 40% in commerce and public services (also referred to as services). The use of electricity in the services sector strongly depends on the region and ranges from 16% in India to 55% in OECD Asia Oceania, see Figure 11.6.

The breakdown of electricity use per type of appliance is different per region. In the Energy [R]evolution scenario, a convergence is assumed for the different types of electricity demand per region in 2050. Based on data in the literature<sup>5</sup>, the following breakdown of electricity use per type is used as default if no specific regional information is available:

- Space heating 10%
- Hot water 10%
- Lighting 20%
- ICT and home entertainment (HE) 12%
- Other appliances 30%
- Air conditioning 18%

**FIGURE 11.6 | BREAKDOWN OF ELECTRICITY USE BY SUB SECTOR IN OTHER SECTORS IN 2012**



source IEA WEO 2014.

**REFERENCES**

<sup>5</sup> IEA (2007) ENERGY USE IN THE NEW MILLENNIUM – TRENDS IN IEA COUNTRIES. OECD/INTERNATIONAL ENERGY AGENCY. IPCC (2007) FOURTH ASSESSMENT REPORT. WORKING GROUP III: MITIGATION OF CLIMATE CHANGE. CAMBRIDGE UNIVERSITY PRESS. IEA (2009) ENERGY TECHNOLOGY TRANSITIONS FOR INDUSTRY: STRATEGIES FOR THE NEXT INDUSTRIAL REVOLUTION. PARIS, FRANCE: OECD/IEA, 2009.

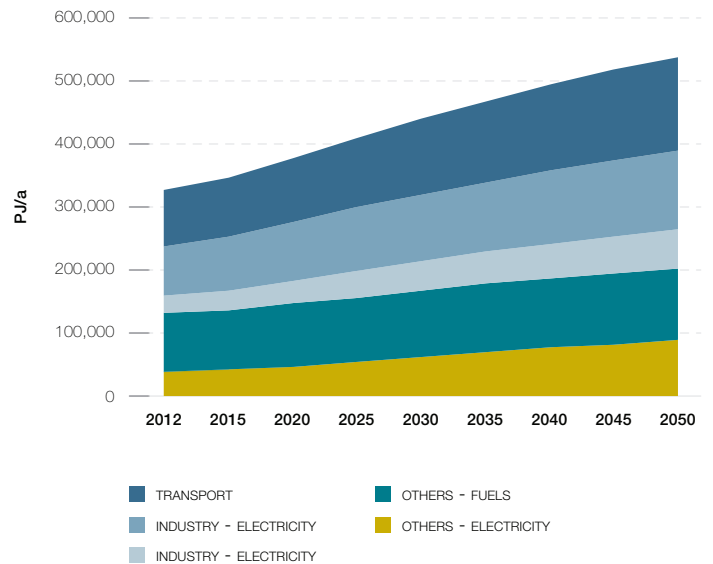
**The trend is moving in the wrong direction:** Energy demand continues to grow for appliances, lighting, and a large array of electrical and fossil fuel-powered equipment, despite significant progress on labelling and mandatory minimum energy performance standards (MEPS). Market penetration of major appliances has increased significantly in emerging markets, and plug loads from electrical devices and network usage continue to grow in all markets, resulting in energy consumption growth of over 50% from 2000 to 2012 (IEA ETP 2015).

**11.3 REFERENCE DEMAND SCENARIO**

Figure 11.7 shows the Reference scenario for final energy demand for the world per sector derived from the IEA WEO 2014.

Worldwide final energy demand is expected to grow by 65%, from 327 Exajoule (EJ) in 2012 to more than 538 EJ in 2050. The electricity demand has the largest relative growth of 120% in Industry and 130% in Other sectors. Fuel demand in Other sectors is expected to grow slowest from 92 EJ in 2012 to 116 EJ in 2050.

**FIGURE 11.7 | FINAL ENERGY DEMAND IN THE REFERENCE SCENARIO PER SECTOR WORLDWIDE**



source IEA WEO 2014 / DLR calculations for Reference case.

In the Reference scenario, final energy demand in 2050 will be largest in China (112 EJ), followed by OECD North America (82 EJ) and India (61 EJ). Final energy demand in OECD Asia Oceania, Middle East and Latin America will be lowest (21 EJ and 36 EJ respectively).

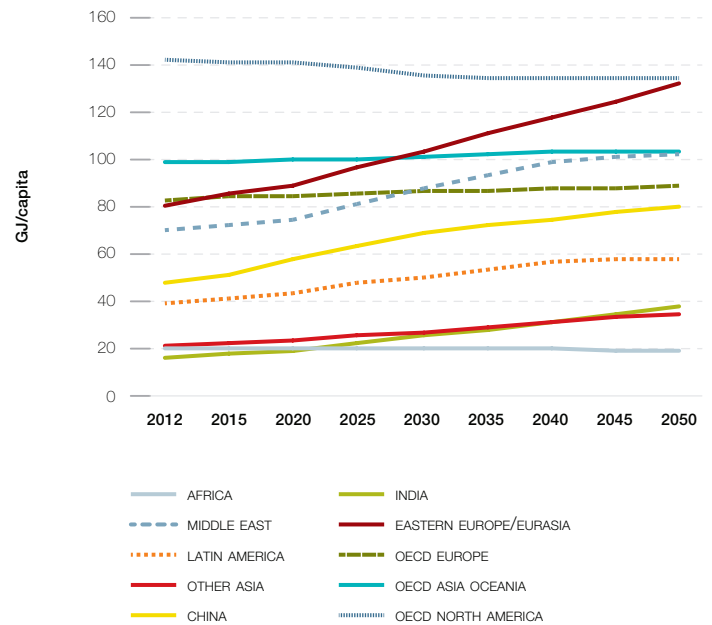
Figure 11.9 shows the development of final energy demand per capita in the Reference scenario.

There would still be large differences between regions for final energy demand per capita in 2050 in the Reference scenario. Energy demand per capita is expected to be highest in OECD North America and Eastern Europe/Eurasia (135 and 132 GJ/capita respectively), followed by OECD Asia Oceania and Middle East (104 and 103 GJ/capita respectively). Final energy demand in Africa, India, other non-OECD Asia, and Latin America is expected to be lowest, ranging from 19-58 GJ/capita.

Figure 11.10 gives the Reference scenario for final energy demand in industries in the period 2012-2050.

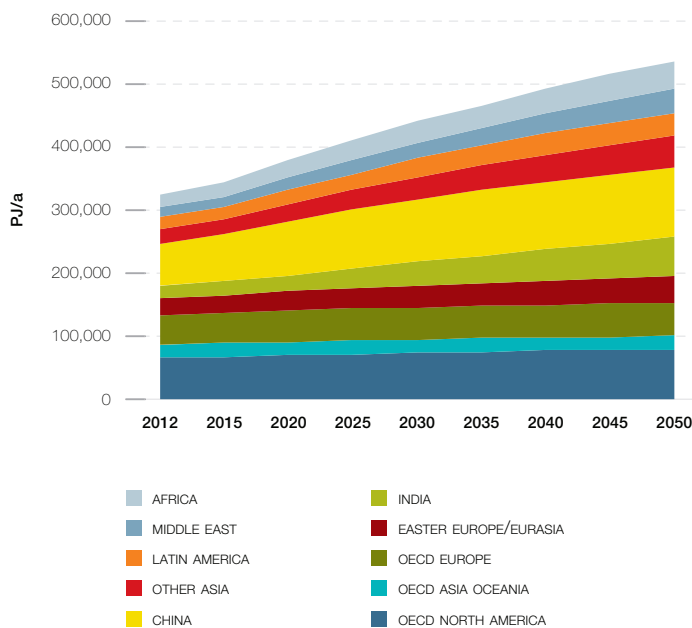
As can be seen, the energy demand in Chinese industries is expected to be huge in 2050 and amount to 54 EJ. The energy demand in all other regions together is expected to be 133 EJ, meaning that China accounts for 29% of worldwide energy demand in industries in 2050.

**FIGURE 11.9 | FINAL ENERGY DEMAND PER CAPITA IN THE REFERENCE SCENARIO**



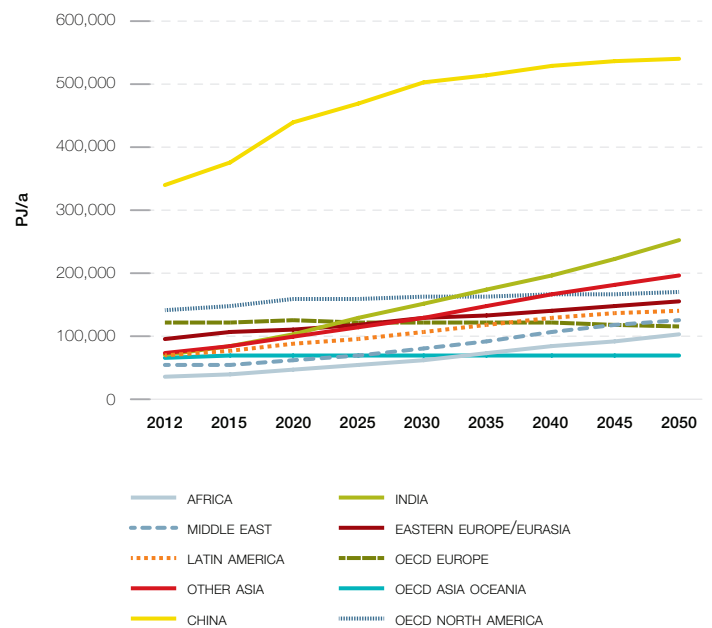
source IEA WEO 2014 / DLR calculations for Reference case.

**FIGURE 11.8 | FINAL ENERGY DEMAND IN THE REFERENCE SCENARIO PER REGION**



source IEA WEO 2014 / DLR calculations for Reference case.

**FIGURE 11.10 | ENERGY DEMAND IN INDUSTRY IN THE REFERENCE SCENARIO PER REGION**



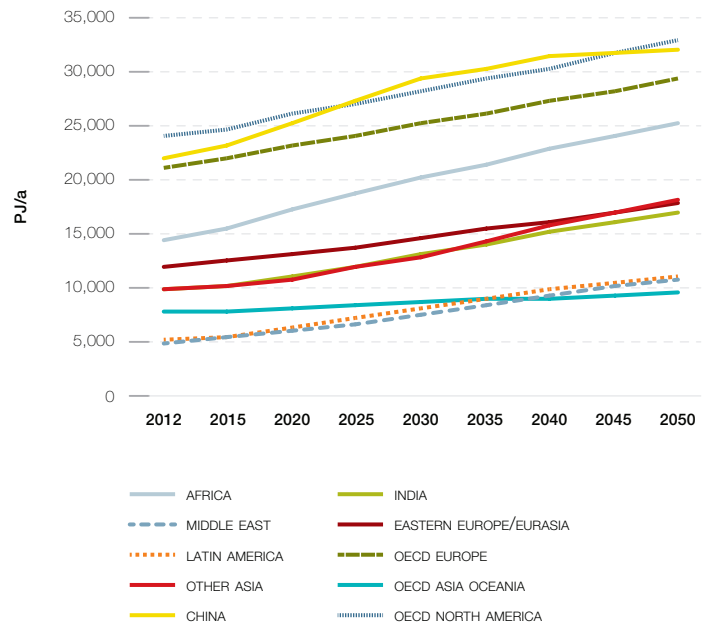
source IEA WEO 2014 / DLR calculations for Reference case.

In the Reference scenario, energy demand in buildings and agriculture is forecast to grow considerably (see Figure 11.11).

Figure 11.11 shows that energy demand in buildings and agriculture in 2050 is highest in OECD North America (33 EJ), followed by China (32 EJ) and OECD Europe (29 EJ). OECD Asia Oceania, Latin America and Middle East have the lowest energy demand for buildings and agriculture, ranging from 9-11 GJ.

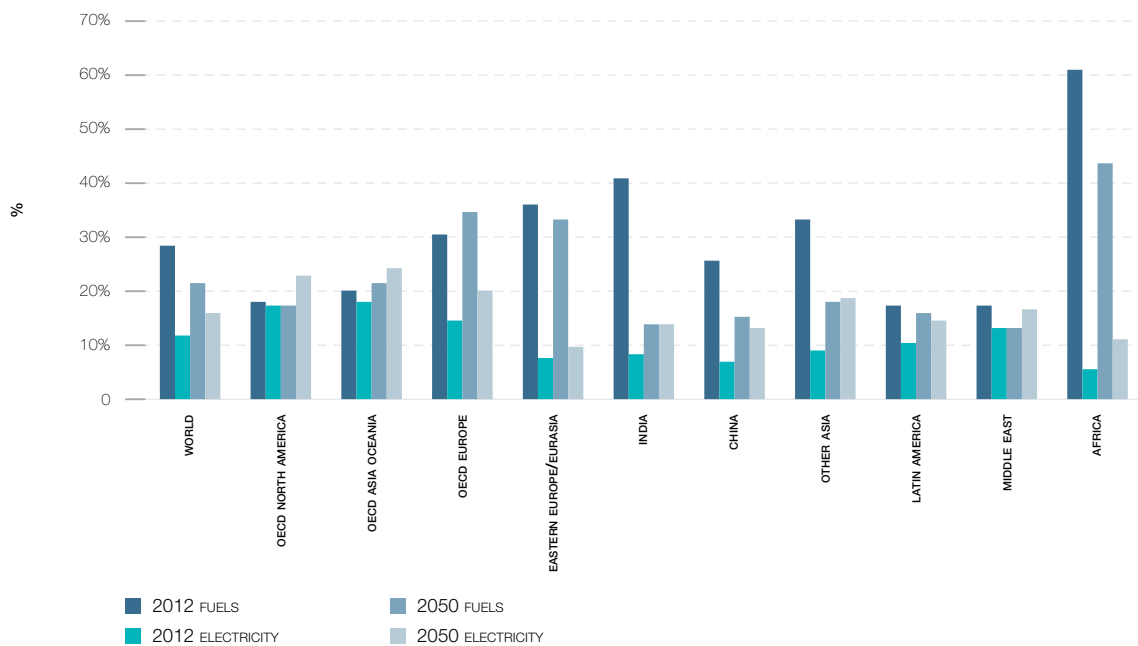
The share of fuel and electricity use by buildings and agriculture in total energy demand in 2012 and 2050 are shown in Figure 11.12. India and Africa have the highest share of buildings and agriculture in total final energy demand today. Until 2050, a sharp decrease is expected in India. Globally, it is expected that electricity use in this sector will be bigger in 2050 than in 2012 (16% instead of 12%) and fuel use will be smaller (22% instead of 28%).

**FIGURE 11.11 | ENERGY DEMAND IN OTHER SECTORS IN THE REFERENCE SCENARIO PER REGION**



source IEA WEO 2014 / DLR calculations for Reference case.

**FIGURE 11.12 | SHARE ELECTRICITY AND FUEL CONSUMPTION BY OTHER SECTORS IN TOTAL FINAL ENERGY DEMAND IN 2012 AND 2050 IN THE REFERENCE SCENARIO**



source IEA WEO 2014 / DLR calculations for Reference case.

## 11.4 EFFICIENCY MEASURES AND POTENTIALS

### 11.4.1 EFFICIENCY MEASURES IN INDUSTRY

The overall technical efficiency potentials are estimated after identifying the most significant energy-efficiency improvements. In the Reference scenario, some of these energy-efficiency improvements have already been implemented (autonomous and policy induced energy-efficiency improvement). This baseline was complemented by a most efficient development pathway assuming all known and characterized efficiency measures in the industry sector as being implemented.

The benchmarking of the industry sector's energy use can provide valuable insights regarding energy efficiency potentials. Energy Efficiency Indicators (EEIs) differ significantly between countries and sectors as a result of differences in resource availability, energy prices, plant size, and the age of capital stock, local factors, capital costs, awareness, opportunity costs and government policies. International energy statistics, which are the basis of the EEI approach, are subject to uncertainties however.

International benchmark studies show large differences for energy intensity on a country level for the iron and steel, chemical and pulp and paper industry. Large energy savings potentials were found in the range of 20-30% on average. This section documents a special survey about industry efficiency potential commissioned by Greenpeace International in 2013

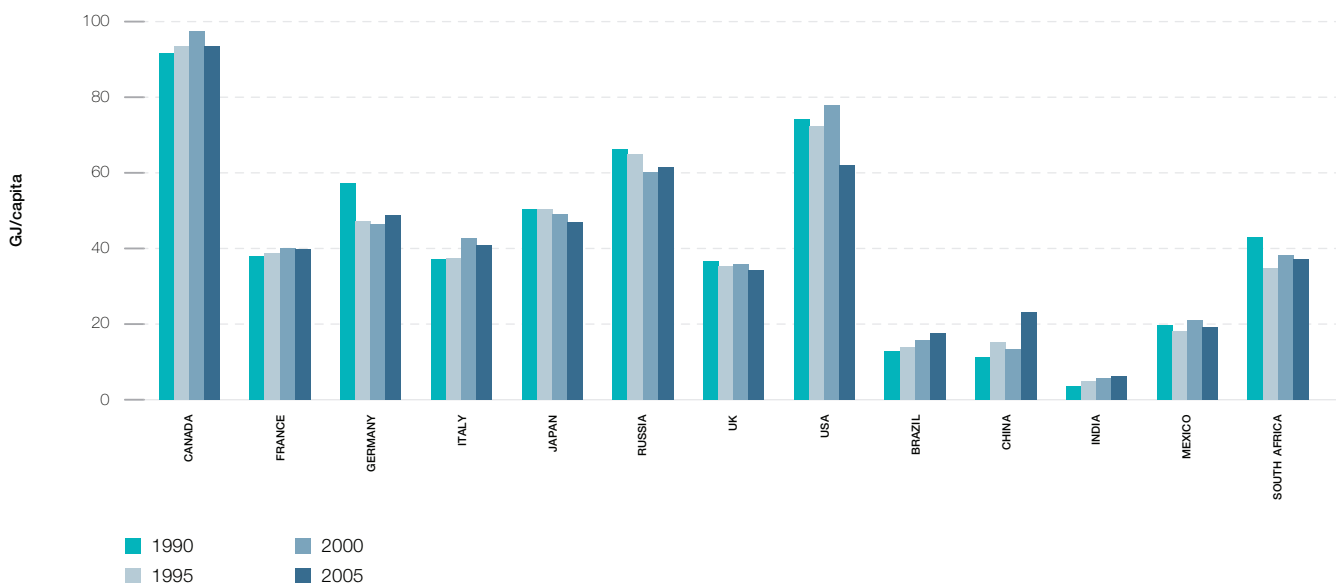
(Uni Utrecht 2013).<sup>6</sup> Unfortunately, there are only very few publications about energy efficiency potentials for various subsectors of the global industry. Thus, consistent data is sometimes up to 10 years old, and there is a need for more in-depth research. Even the Global Energy Assessment report – published in 2012 – refers to data from 2007 and 2005.

#### Iron and steel

Most sectors in manufacturing industry produce a range of products, so it is generally not possible to apply a simple indicator of energy efficiency in energy use per tonne of product. Instead, an aggregate indicator, the energy efficiency index (EEI) is used. A decrease of the EEI means that the energy use per unit of product was reduced.

Figure 11.13 shows the development of the energy efficiency index for the iron and steel industry for G8+5 countries. For all countries together, the energy efficiency improvement amounted to 9 % between 2000 and 2005 (1.8 per cent per year). It is striking that in some countries (such as South Africa), energy efficiency deteriorated, which may be caused by the strong increase in steel demand, leading companies to take less efficient plants into operation again. Also remarkable is the strong progress in energy efficiency in China (7.4%/a) and India (7.9%/a), most likely through the rapid expansion of production capacity with relatively efficient technology (REEEP, 2008).<sup>7</sup>

FIGURE 11.13 | ENERGY EFFICIENCY INDEX FOR IRON AND STEEL INDUSTRY PRIMARY ENERGY USE PER CAPITA



source REEEP, 2008.

#### REFERENCES

- 6 (UNIUTRECHT 2013); BACKGROUND MATERIAL ABOUT THE ENERGY INTENSIVE INDUSTRIES IN THE 30 % DEBATE; FOR INTERNAL USE WITHIN GREENPEACE; WINA GRAUS (UU); MIRJAM HARMELINK (HARMELINK CONSULTING); DIAN PHYLIPSEN (PHYLIPSEN CLIMATE CHANGE CONSULTING); MARIËLLE CORSTEN (UU); JUNE 2013.
- 7 (REEEP 2008) GLOBAL STATUS REPORT ON ENERGY EFFICIENCY 2008.

Figure 11.13 indicates that iron and steel plants in Japan are most efficient, followed by plants in Germany. Among the included EU countries, the EEIs for the UK and Italy are relatively high and imply high overall energy efficiency improvement potentials in the range of 35-45% on average. Significant differences exist in energy efficiency and CO<sub>2</sub> emission intensity of steel production among countries and production plants. These differences can, partly, be explained by variations in the quality of the resources and the cost of energy (IEA, 2008a).<sup>8</sup> Low energy efficiencies in some countries reflect traditionally very low energy prices and decreasing production volumes. However, in many countries production has increased in recent years and energy prices have risen substantially, already resulting in energy efficiency improvements (IEA, 2008a). Furthermore, factors such as good housekeeping, process control and level of waste heat recovery may also explain the differences in energy and CO<sub>2</sub> emission intensity.

### Chemicals

Table 11.1 shows an energy efficiency index of chemical industry on country level. Note that the EEI is inverted in comparison to the EEI for the iron and steel industry, here a higher EEI means higher energy efficiency. The EEI implies a global average energy savings potential in the chemical industry of 18% by implementing best practice technology.

**TABLE 11.1 | ENERGY EFFICIENCY OF CHEMICAL AND PETROCHEMICAL INDUSTRY**

	REPORTED ENERGY USE PJ	BPT CALCULATED ENERGY USE	ENERGY EFFICIENCY INDEX	IMPROVEMENT POTENTIAL
USA	6,862	4,887	0.70	29.8
JAPAN	2,130	1,917	0.90	10.0
CHINA	3,740	2,975	0.80	20.5
SAUDI ARABIA	1,115	917	0.82	17.8
GERMANY	1,157	1,044	0.90	9.8
NETHERLANDS	618	508	0.82	17.8
FRANCE	654	582	0.88	11.0
BRAZIL	577	478	0.83	17.2
UK	490	460	0.94	6.2
INDIA	1,091	910	0.84	15.8
CHINESE TAIPEI	741	599	0.81	19.2
ITALY	389	365	0.94	6.2
WORLD	28,819	23,682	0.82	17.8

source IEA, 2007.

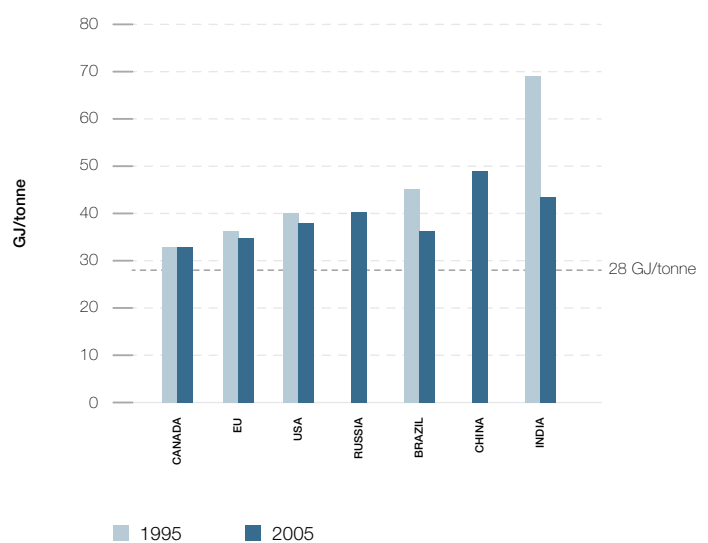
Values range from 0.7 for the US to 0.94 for Italy. Generally a determining factor in the energy efficiency index is the age of plants, where older plants are less efficient than newer plants. However, retrofits can invalidate this rule of thumb. A global analysis indicates that chemical plants built in the 1970s are the least efficient. The 1950 – 60s production plants had a significant amount of upgrading, especially after the 1973 oil price crisis, and show relatively good performance (IEA, 2007).

Due to the high diversity in terms of products produced in the chemical industry it is worthwhile to look into energy efficiency indicators for different products; such as the following example of energy efficiency potential for the production of ammonia.

### Ammonia production

The specific energy use for ammonia production (including feed stocks) for G8+5 is given in Figure 11.14. G8 countries for which data are available show a slow decline in specific energy use in 2005 in comparison to 1995. The average progress (weighted according to production volumes) is 15 % over the period from 1995-2005 (1.7 % per year). Also, in this case progress in developing countries (Brazil and India) is much faster. The specific energy consumption in China is highest and reveals a large efficiency improvement potential.

**FIGURE 11.14 | SPECIFIC ENERGY CONSUMPTION IN AMMONIA (NH<sub>3</sub>) PRODUCTION IN 1995 AND 2005**



note The dotted line indicates the best-practice level for ammonia (NH<sub>3</sub>) production in 1995 and 2005. source REEEP, 2008.

### REFERENCES

<sup>8</sup> (IEA 2008a) WORLD TRENDS IN ENERGY USE AND EFFICIENCY – KEY INSIGHTS FROM IEA INDICATOR ANALYSIS. INTERNATIONAL ENERGY AGENCY, PARIS.

### Pulp and paper industry

Table 11.2 shows an energy efficiency index (EEI) for the pulp and paper industry for a selection of countries. The EEI is based on best practice values for pulp and paper production and actual energy use in countries for pulp and paper production (both in GJ/ton). An EEI of 1.4 means that energy use of pulp and paper production is 40% above best practice, so this implies a savings potential by implementing best practice technology of 40% in comparison to current energy use.

Based on the EEI in Table 11.2 Japan and South Korea are most efficient in terms of pulp and paper production, whereas the US and Canada have the lowest energy efficiency. Over the last decade, the South Korean paper industry has invested heavily in relatively efficient capacity expansion (IEA, 2007).<sup>9</sup> Canada's comparatively low energy efficiency, on the other hand, may be attributed to a high level of energy use in older newsprint mills. Also cheap hydroelectric power and the use of wood waste with low efficiency could explain the low EEI in Canada (IEA, 2007).

### Energy efficiency improvement potentials and barriers

The largest potential for energy efficiency improvement can be found when replacing older plants by new capacity. The long term potential is at least 20-30% (on average), based on implementing *Best Available Techniques* (BAT), and can increase in the future by emerging technologies that become available. In general, high energy efficiency improvement rates in industry require timely retirement of old/less efficient capacity. Retrofitting a 30-year-old plant so it can last another 20 years is disadvantageous from an energy efficiency point of view because the largest improvement potential is available when building new capacity, where plants can be completely redesigned.

Many studies show negative costs for most energy efficiency measures in industry, meaning that the payback time of measures is below their lifetime. It should be noted though that not all steps taken are necessarily profitable from a company's perspective although most measures payback within their lifetime. Investment criteria in terms of desired payback times, restrictions to the height of up-front capital costs and opportunity costs in the end determine the attractiveness of measures. Furthermore, companies can be very hesitant to implement measures that might (temporarily) reduce plant reliability. The most important barriers that can prevent energy efficiency and emission reduction measures from being implemented and inhibit investment in technologies that are both energy efficient and economically efficient include:

- Capital goods have not yet been fully depreciated;
- The lack of access to capital for investments in energy efficiency measures and emission reduction measures;
- Investments in other projects within the company are considered more important or more efficient.

Literature provides ample empirical evidence for the existence of such barriers in the industry sector.

**TABLE 11.2 | ENERGY EFFICIENCY INDEX OF PULP AND PAPER PRODUCTION**

	EEI
JAPAN	0.9-1.2
SOUTH KOREA	1.0-1.2
AUSTRIA	1.0
SPAIN	1.1
UK	1.1
BELGIUM	1.2
FINLAND	1.2
FRANCE	1.2
GERMANY	1.2
ITALY	1.3
SWEDEN	1.4
USA	1.7
CANADA	2.0

source Kuramochi, 2006.

### REFERENCES

<sup>9</sup> (IEA 2007). TRACKING INDUSTRIAL ENERGY EFFICIENCY AND CO2 EMISSIONS. INTERNATIONAL ENERGY AGENCY, PARIS, FRANCE.

### 11.4.2 EFFICIENCY MEASURES IN BUILDINGS

A summary of possible energy saving measures for each of the three types of fuel/heat use is provided here.

#### Space heating

Globally, buildings accounted for 32% (118.6 EJ) of final energy consumption in 2012 and 53% of global electricity consumption (IEA ETP 2015).<sup>10</sup> Energy-efficiency improvement for space heating is indicated by the energy demand per m<sup>2</sup> floor area per heating degree day (HDD). Heating degree day is the number of degrees that a day's average temperature is below 18° Celsius. Typical current heating demand for dwellings in OECD countries is 70-120 kJ/m<sup>2</sup>/HDD (based on IEA, 2007), but those with better efficiency consume below 32 kJ/m<sup>2</sup>/HDD.<sup>11</sup> The European Union, which has made the most progress compared to other regions, requires member countries to include cost optimality as a criterion when developing building codes. France, for example, has enacted a building code that limits space heating, water heating, cooling and lighting energy to 50 kWh/m<sup>2</sup> or less (IEA ETP 2015).

An example of a household with low energy use is given in Figure 11.15.

Technologies to reduce energy demand of new dwellings are:<sup>12</sup>

- Triple-glazed windows with low-emittance coatings. These windows reduce heat loss to 40% compared to windows with one pane. The low-emittance coating prevents energy waves in sunlight coming in and thereby reduces cooling need.
- Insulation of roofs, walls, floors and basement. Proper insulation reduces heating and cooling demand by 50% in comparison to average energy demand.
- Passive solar energy. Good building design can make use of solar energy design, through orientation of the building's site and windows. The term "passive" indicates that no mechanical equipment is used, because solar gains are brought in through windows and shading keeps the heat out in summer.
- Balanced ventilation with heat recovery. Heated indoor air passes to a heat recovery unit and is used to heat incoming outdoor air.

**FIGURE 11.15 | ELEMENTS OF NEW BUILDING DESIGN THAT CAN SUBSTANTIALLY REDUCE ENERGY USE**

PRIMARY ENERGY USE PER CAPITA



source WBCSD, 2005.

#### REFERENCES

- <sup>10</sup> (IEA ETP 2015); ENERGY TECHNOLOGY PERSPECTIVES 2015 – TRACKING CLEAN ENERGY PROCESS; INTERNATIONAL ENERGY AGENCY; JUNE 2015.
- <sup>11</sup> THIS IS BASED ON A NUMBER OF ZERO-ENERGY DWELLING IN THE NETHERLANDS AND GERMANY, CONSUMING 400-500 M<sup>3</sup> NATURAL GAS PER YEAR, WITH A FLOOR SURFACE BETWEEN 120 AND 150 M<sup>2</sup>. THIS RESULTS IN 0.1 GJ/M<sup>2</sup>/YR AND IS CONVERTED BY 3100 HEATING DEGREE DAYS TO 32 KJ/M<sup>2</sup>/HDD.
- <sup>12</sup> WBCSD (WORLD BUSINESS COUNCIL ON SUSTAINABLE DEVELOPMENT) (2005). PATHWAYS TO 2050 – ENERGY AND CLIMATE CHANGE.  
IEA (2006). ENERGY TECHNOLOGY PERSPECTIVES – SCENARIOS AND STRATEGIES TO 2050. OECD/IEA, 2006.



For existing buildings, retrofits help reduce energy use. Important retrofit options are more efficient windows and insulation, which can save 39% and 32% of space heating or cooling demand, respectively, according to the International Energy Agency (IEA 2006). Furthermore, the IEA reports that average energy consumption in current buildings in Europe can decrease overall by more than 50%. In 2015, the IEA reconfirmed that energy use by space heating, cooling and lighting, which represents 38% of global buildings energy consumption, could be reduced by more than half by ensuring that building envelopes are energy efficient (IEA ETP 2015). While the technologies are there, the political process is far too slow to exploit these large cost effective efficiency potentials.

To improve the efficiency of existing heating systems, an option is to install new thermostatic valves, which can save 15% of energy required for heating. On average, this option is installed in an estimated 40% of systems in Europe.<sup>13</sup> Effective air sealing can reduce heating and cooling energy by 20% to 30% and needs to be implemented as part of any construction and renovation project. More effort is needed globally to ensure that any building that will be heated or cooled is properly sealed. When sealing is done correctly, with controlled ventilation and advanced heat recovery, it can improve indoor air quality (IEA ETP 2015).

Besides reducing the demand for heating, another option is to improve the conversion of efficiency of heat supply. A number of options are available, such as high efficiency boilers that can achieve efficiencies of 107%, based on lower heating value. Another option is the use of heat pumps.

### Hot water and cooking

Energy savings options for hot water include pipe insulation and high efficiency boilers. Another option is heat recovery units that capture the waste heat from water going down the drain and use it to preheat cold water before it enters the household water heater. A heat recovery system can recover as much as 70% of this heat and recycle it back for immediate use.<sup>14</sup> Furthermore, water-saving shower heads and flow inhibitors can be implemented. The typical saving rate (in terms of energy) for shower heads is 12.5% and 25% for flow inhibitors.<sup>15</sup> In developing regions, improved cook stoves can be an important energy-efficiency option, which consume less energy than conventional ones.<sup>16</sup>

### Electricity use

Electricity savings options per application are discussed in the following.

### Electricity for space heating and hot water

Measures to reduce electricity use for space heating and hot water are similar to measures for heating by fuels. Changing the building shell can reduce the need for heat, and the other approach is to improve the conversion efficiency of heat supply, for example with heat pumps to provide both cooling and space and water heating, as discussed in Chapter 10 (Renewable Heating and Cooling Technologies). Typically, heat pumps can produce from 2.5 to 4 times as much useful heat as the amount of high-grade energy input, with variations due to seasonal performance. The sales of heat pumps in a number of major European markets experienced strong growth in recent years. Total annual sales in Austria, Finland, France, Germany, Italy, Norway, Sweden and Switzerland reached 636,000 in 2013, compared to 446,000 in 2005.<sup>17</sup> Data suggests that heat pumps may be beginning to achieve a critical mass for space and water heating in a number of European countries.

### Lighting

Incandescent bulbs have been the most common lamps for a more than 100 years but also the most inefficient type since up to 95% of the electricity is lost as heat.<sup>18</sup> Incandescent lamps have a relatively short life-span (average approximately 1,000 hours) but have a low initial cost and attractive light colour. Compact Fluorescent Light Bulbs (CFLs) are more expensive than incandescent, but they use about a quarter of the energy and last about 10 times longer.<sup>19</sup> In recent years, many policies have been implemented that reduce or ban the use of incandescent light bulbs in various countries.

However, energy savings from lighting are not just a question of using more efficient lamps but also involve other approaches: reducing light absorption of luminaries (the fixture in which the lamp is housed), optimizing lighting levels (which commonly exceed values recommended by IEA (2006)), using automatic controls like movement and daylight sensors, and retrofitting buildings to make better use of daylight. Buildings designed to optimize daylight can receive up to 70% of their annual illumination needs from daylight, while a typical building will only get 20 to 25%.

The light-emitting diode (LED) is one of today's most energy-efficient and rapidly-developing lighting technologies. LED is a highly energy efficient lighting technology and has the potential to fundamentally change the future of lighting. Residential LEDs use at least 75% less energy, and last 25 times longer than incandescent lighting.<sup>20</sup>

### REFERENCES

- 13 BETTGENHÄUSER, K., T. BOERMANS AND S. SCHIMSCHAR (2009) SECTORAL EMISSION REDUCTION POTENTIALS AND ECONOMIC COSTS FOR CLIMATE CHANGE (SERPEC-CC), RESIDENTIAL BUILDINGS AND SERVICE SECTOR. ECOFYS, NETHERLANDS.
- 14 ENVIROHARVEST (2008) HEAT RECOVERY. [HTTP://WWW.ENVIROHARVEST.CA/HEAT\\_RECOVERY.HTM](http://www.enviroharvest.ca/heat_recovery.htm)
- 15 BETTGENHÄUSER, K., T. BOERMANS AND S. SCHIMSCHAR (2009) SECTORAL EMISSION REDUCTION POTENTIALS AND ECONOMIC COSTS FOR CLIMATE CHANGE (SERPEC-CC), RESIDENTIAL BUILDINGS AND SERVICE SECTOR. ECOFYS, NETHERLANDS.

- 16 REEEP (2009) IMPLEMENTATION OF A DISSEMINATION STRATEGY FOR EFFICIENT COOK STOVES IN NORTHEAST BRAZIL.
- 17 (EHPA 2014) EUROPEAN HEAT PUMP MARKET AND STATISTICS REPORT – EUROPEAN HEAT PUMP ASSOCIATION.
- 18 HENDEL-BLACKFORD, S., T. ANGELINI, S. OZAWA (2007) ENERGY EFFICIENCY IN LIFE-STYLES: EUROPE AND JAPAN. ECOFYS FOR EU-JAPAN CENTRE FOR INDUSTRIAL COOPERATION.
- 19 ENERGY STAR (2008) COMPACT FLUORESCENT LIGHT BULBS. [HTTP://WWW.ENERGYSTAR.GOV/INDEX.CFM?c=CFLS.PR\\_CFLS](http://www.energystar.gov/index.cfm?c=cfls.pr_cfls)
- 20 (USA-ENERGY-GOV 2014) ENERGY.GOV WEBSITE ([HTTP://ENERGY.GOV/ENERGYSAVER/ARTICLES/LED-LIGHTING](http://energy.gov/energysaver/articles/led-lighting)), U.S. DEPARTMENT OF ENERGY, 1000 INDEPENDENCE AVE. SW WASHINGTON DC 20585 / USA; NOVEMBER 2014.

### ICT and home entertainment equipment

Information and communication technologies (ICT) and home entertainment consist of a growing number of appliances in both residential and commercial buildings, such as computers, (smart) phones, televisions, set-top boxes, games consoles, printers, copiers and servers. ICT and consumer electronics account for about 15% of residential electricity consumption now.<sup>21</sup> Globally, a tripling is expected for ICT and consumer electronics from 776 TWh/a in 2010 to 1,700 TWh/a in 2030. One of the main options for reducing energy use in ICT and home entertainment is using best available technology. IEA (2009b) estimates that a reduction is possible from 1,700 TWh/a to 775 TWh/a in 2030 by applying best available technology and to 1,220 TWh/a by least life-cycle costs measures, which do not impose additional costs on consumers. Below, we discuss other energy savings options for ICT and home entertainment.

### Other appliances

Other appliances include cold appliances (freezers and refrigerators), washing machines, dryers, dish washers, ovens and other kitchen equipment. Electricity use for cold appliances depends on average per household storage capacities, the ratio of frozen to fresh food storage capacity, ambient temperatures and humidity, and food storage temperatures and control (IEA, 2003). European and Japanese households typically have one combined refrigerator-freezer in the kitchen or they have a refrigerator and a separate freezer. In OECD North America and Australia, where homes are larger, almost all households have a refrigerator-freezer, and many also have a separate freezer and occasionally a second refrigerator.<sup>22</sup> It is estimated that by improving the energy efficiency of cold appliances, on average 45% of electricity use could be saved for EU-27.<sup>23</sup> For “wet appliances,” an estimated potential of 40-60% could be saved by implementing best practice technology.

### Air conditioning

There are several options for technological savings from air conditioning equipment; one is using a different refrigerant. Tests with the refrigerant Ikon B show possible energy consumption reductions of 20-25% compared to refrigerants commonly used.<sup>24</sup>

#### REFERENCES

- 21 IEA (2009b) GADGETS AND GIGAWATTS. INTERNATIONAL ENERGY AGENCY. PARIS, FRANCE.
- 22 IEA (2003) COOL APPLIANCES - POLICY STRATEGIES FOR ENERGY EFFICIENT HOMES. [HTTPS://WWW.IEA.ORG/TEXTBASE/NPPDF/FREE/2000/COOL\\_APPLIANCE2003.PDF](https://www.iea.org/textbase/nppdf/free/2000/cool_appliance2003.pdf)
- 23 BETTGENHAUSER ET AL. (2009).
- 24 US DOE EERE (UNITED STATES DEPARTMENT OF ENERGY; ENERGY EFFICIENCY AND RENEWABLE ENERGY) (2008) INVENTIONS & INNOVATION PROJECT FACT SHEET. HIGH ENERGY EFFICIENCY AIR CONDITIONING. [HTTP://WWW1.EERE.ENERGY.GOV/INVENTIONS/PDFS/NIMITZ.PDF](http://www1.eere.energy.gov/inventions/pdfs/nimitz.pdf)
- 25 DARLING, D. (2005) SOLAR COOLING. THE ENCYCLOPEDIA OF ALTERNATIVE ENERGY AND SUSTAINABLE LIVING. [HTTP://WWW.DAVIDDARLING.INFO/ENCYCLOPEDIA/S/AE\\_SOLAR\\_COOLING.HTML](http://www.daviddarling.info/encyclopedia/s/ae_solar_cooling.html)
- 26 AUSTRIAN ENERGY AGENCY. 2006 - NOTE THAT SOLAR COOLING AND GEOTHERMAL COOLING MAY REDUCE THE NEED FOR HIGH GRADE ENERGY SUCH AS NATURAL GAS AND ELECTRICITY. ON THE OTHER HAND THEY INCREASE THE USE OF RENEWABLE ENERGY. THE ENERGY SAVINGS ACHIEVED BY REDUCING THE NEED OF HIGH GRADE ENERGY WILL BE PARTLY COMPENSATED BY AN INCREASE OF RENEWABLE ENERGY.
- 27 US EPA (UNITED STATES ENVIRONMENTAL PROTECTION AGENCY) (2007) COOL ROOFS. [HTTP://WWW.EPA.GOV/HEATISLD/STRATEGIES/COOLROOFS.HTML](http://www.epa.gov/heatisld/strategies/coolroofs.html)
- 28 ACEEE (AMERICAN COUNCIL FOR AN ENERGY-EFFICIENT ECONOMY) (2007) CONSUMER GUIDE TO HOME ENERGY SAVINGS - COOLING EQUIPMENT. [HTTP://WWW.ACEEE.ORG/CONSUMERGUIDE/COOLING.HTM#REDUCE](http://www.aceee.org/consumerguide/cooling.htm#reduce)

Geothermal cooling is another important option explained in Chapter 10. Of several technical concepts available, the highest energy savings can be achieved with two storage reservoirs in aquifers where cold water is used from the cold reservoir in summer. The hot reservoir can be used with a heat pump for heating in winter.

Solar energy can also be used for heating and cooling; the different types are also discussed in Chapter 10 Renewable Heating and Cooling. Heat pumps and air conditioners that can be powered by solar photovoltaic systems,<sup>25</sup> for example, use only 0.05 kW electric power instead of 0.35 kW for regular air conditioning.<sup>26</sup>

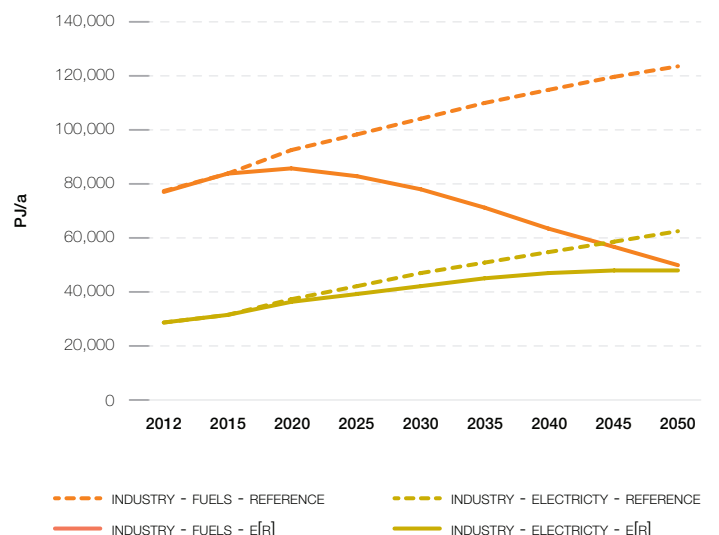
In addition to efficient air conditioning equipment, it is as important to reduce the need for air conditioning. Insulation can be used to prevent heat from entering the building along with fewer inefficient appliances in the house (such as incandescent lamps, old refrigerators, etc.) that give off heat, cool exterior finishes (such as cool roof technology<sup>27</sup> and light-coloured paint on the walls) to reduce the peak cooling demand as much as 10-15%<sup>28</sup>, better windows, vegetation to reduce the amount of heat that comes into the house, and ventilation instead of air conditioning units.

## 11.5 EFFICIENCY PATHWAYS OF THE ENERGY [R]EVOLUTION

### 11.5.1 LOW DEMAND SCENARIO FOR INDUSTRY SECTOR

Figure 11.16 shows the resulting energy demand scenarios for the sector industry on a global level. Energy demand in

**FIGURE 11.16 | GLOBAL FINAL ENERGY USE IN THE PERIOD 2012-2050 IN INDUSTRY IN THE ENERGY [R]EVOLUTION AND THE REFERENCE DEMAND SCENARIO DISTINGUISHED BY ELECTRICITY AND FUELS/HEAT**



source IEA WEO 2014 / DLR calculations for Reference and E[R] case (2015).

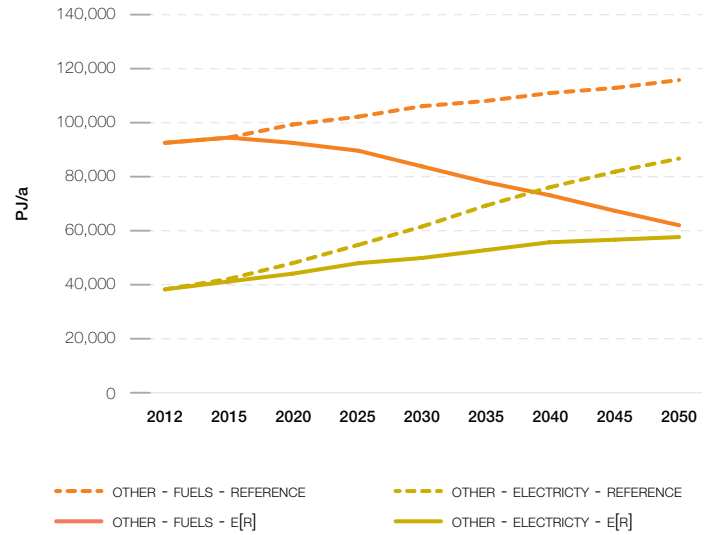
electricity can be reduced by 23% and nearly 60% for fuel use, in comparison to the Reference scenario in 2050. In comparison to 2012, global fuel use in industry decreases from 78 EJ to 50 EJ and electricity use shows an increase from 29 EJ to 48 EJ which is also a result of the substitution of fuel use for heating with electric heating systems.

Figure 11.17 shows the final energy demand in the industrial sector per region for total energy demand. Large reductions are assumed in all regions, especially in the developing countries.

### 11.5.2 LOW DEMAND SCENARIO FOR BUILDINGS AND OTHER SECTORS

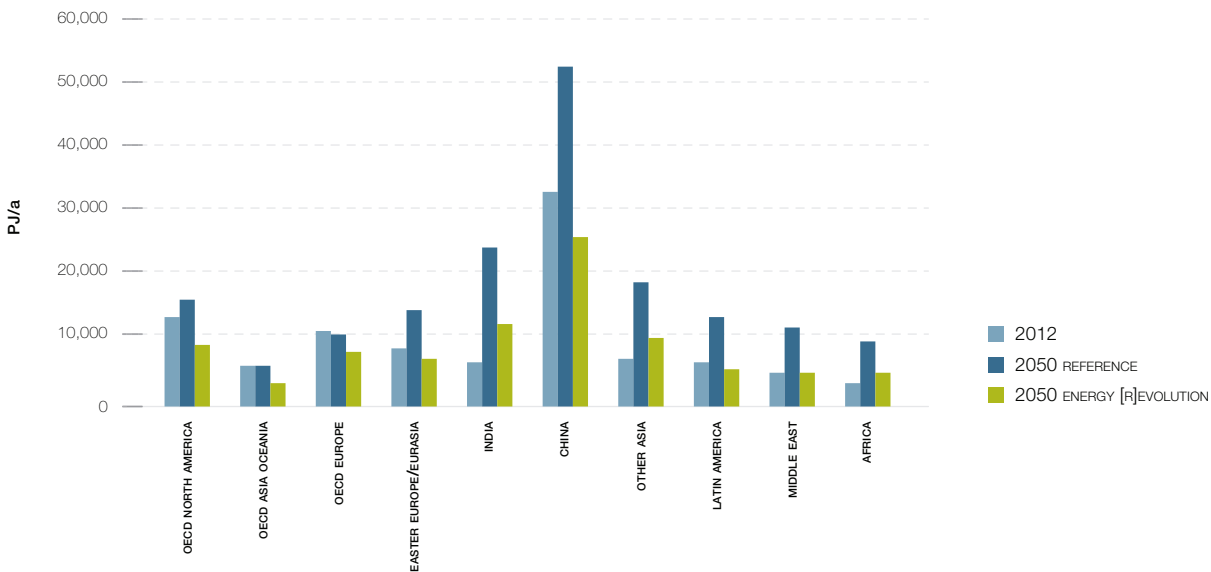
Figure 11.18 shows the resulting energy demand scenarios for the buildings and agriculture sector on a global level. Energy demand for electricity is reduced by 33% and for fuel by 46%, in comparison to the Reference scenario in 2050. In comparison to 2012, global fuel use in this sector decreases from 92 EJ to 62 EJ while electricity use shows a strong increase from 38 EJ to 58 EJ.

**FIGURE 11.18 | GLOBAL FINAL ENERGY USE IN THE PERIOD 2012-2050 IN OTHER SECTORS IN THE ENERGY [R]EVOLUTION AND THE REFERENCE SCENARIO DISTINGUISHED BY ELECTRICITY AND FUELS/HEAT**



source IEA WEO 2014 / DLR calculations for Reference and E[R] case (2015).

**FIGURE 11.17 | FINAL ENERGY USE IN SECTOR INDUSTRY IN THE ENERGY [R]EVOLUTION AND THE REFERENCE DEMAND SCENARIO DISTINGUISHED BY WORLD REGIONS**



source IEA WEO 2014 / DLR calculations for Reference and E[R] case (2015).

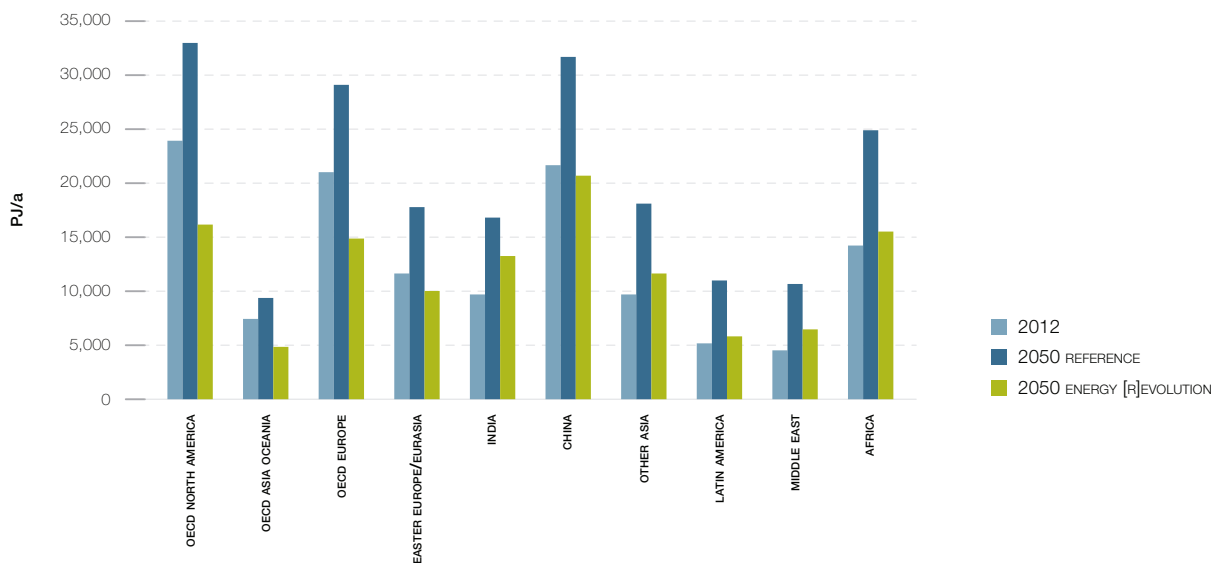
Figure 11.19 shows the final energy demand in the buildings and agriculture (= Other sectors) per region for total final energy demand. Decreases in absolute terms are strongest in the OECD regions while in most developing countries population will further grow and the use of electronic and other devices will further proliferate.

### 11.6 DEVELOPMENT OF ENERGY INTENSITIES

Resulting specific energy consumption in Transport, Industry and Other sectors are shown in Figure 11.20 to Figure 11.22 in terms of global averages and in Figure 11.23 for each world region as total final energy demand of all sectors. Energy intensity in Transport and Industry decreases significantly already in the Reference scenario while in the Energy [R]evolution scenario an even stronger decoupling of economic growth and energy consumption is assumed. Specific electricity demand in Other sectors increases only slightly from 5.6 to 6.1 GJ per capita (1,550 kWh/capita to 1,690 kWh/capita) while specific fuel demand

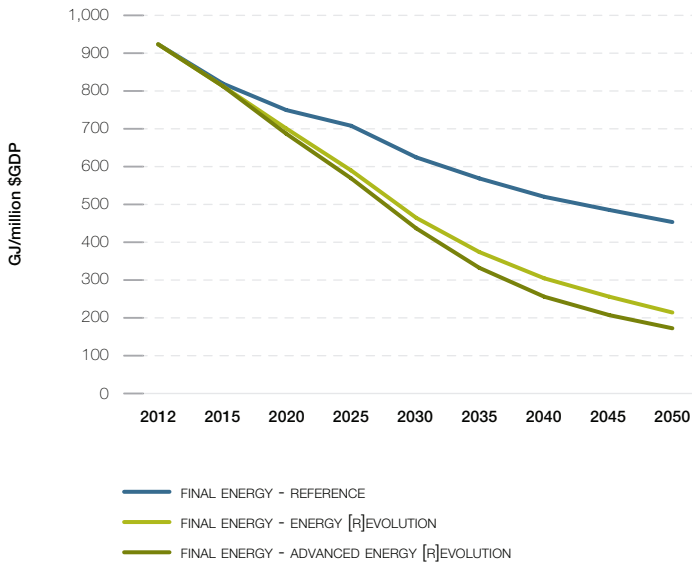
decreases strongly due to the implementation of ambitious efficiency measures for heating in the Energy [R]evolution. The resulting energy intensities for different world regions show a convergence until 2050 but still large differences between developed and developing countries which are a result of the economic and population growth assumptions, assumed developments in the Reference scenario according to WEO 2014 and the assumption that available efficiency potentials are implemented in all world regions. Different assumptions for economic growth and their consequences for lifestyle are possible especially for Africa, India and other Asia and may lead to significant higher demand pathways and therefore higher infrastructural needs for a secure energy supply. Further research is needed here in order to take into account different societal and economic pathways and how these could affect energy demand in different world regions. On the other side an even larger deployment of potentials for renewable energies is possible in most regions and can ensure that requirements for an additional energy supply can be met.

**FIGURE 11.19 | FINAL ENERGY USE IN OTHER SECTORS IN THE ENERGY [R]EVOLUTION AND THE REFERENCE SCENARIO DISTINGUISHED BY WORLD REGIONS**



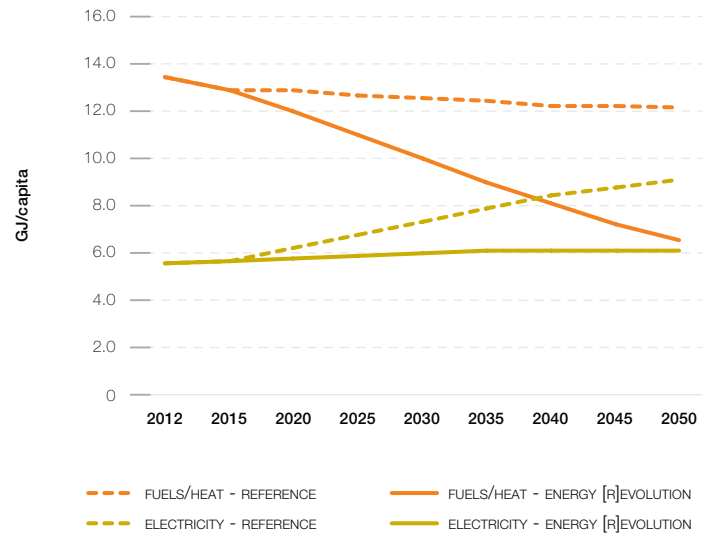
source IEA WEO 2014 / DLR calculations for Reference and E[R] case (2015).

**FIGURE 11.20 | AVERAGE GLOBAL ENERGY INTENSITIES IN TRANSPORT – FINAL ENERGY PER \$ GDP IN THE ENERGY [R]EVOLUTION AND THE REFERENCE SCENARIO**



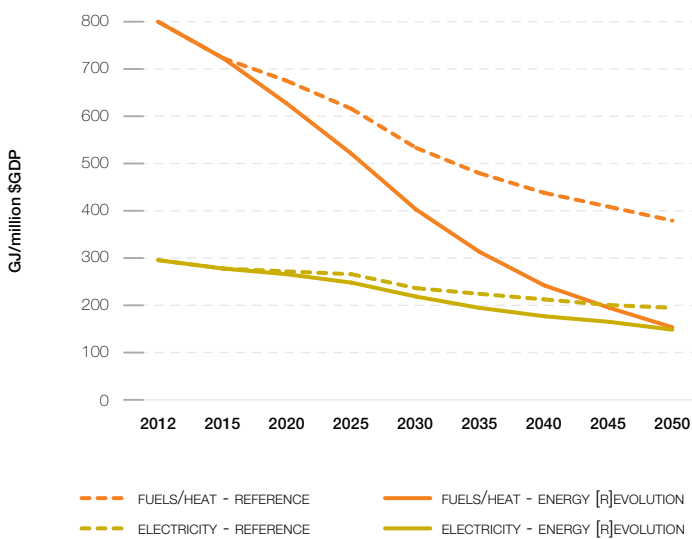
source IEA WEO 2014 / DLR calculations for Reference and E[R] case (2015).

**FIGURE 11.22 | AVERAGE GLOBAL ENERGY INTENSITIES IN OTHER SECTORS – ELECTRICITY AND FUELS/HEAT DEMAND PER CAPITA IN THE ENERGY [R]EVOLUTION AND THE REFERENCE SCENARIO**



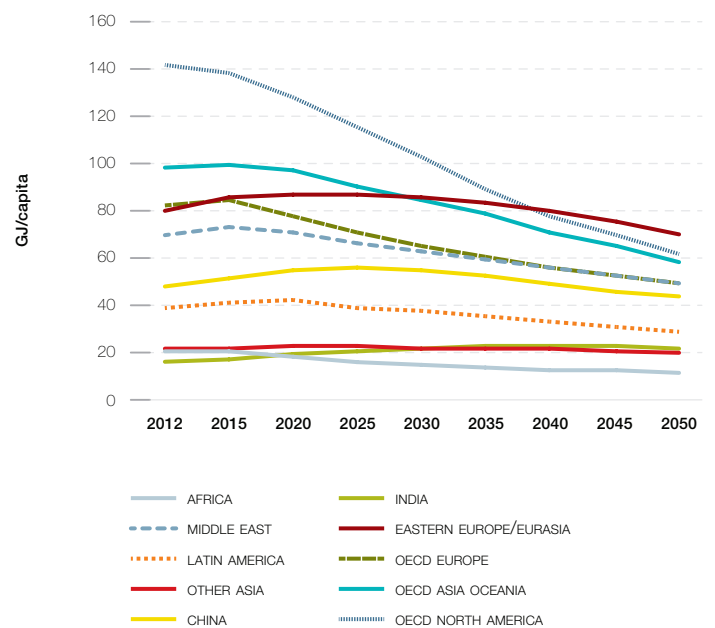
source IEA WEO 2014 / DLR calculations for Reference and E[R] case (2015).

**FIGURE 11.21 | AVERAGE GLOBAL ENERGY INTENSITIES IN INDUSTRY – ELECTRICITY AND FUELS/HEAT DEMAND PER \$ GDP IN THE ENERGY [R]EVOLUTION AND THE REFERENCE SCENARIO**



source IEA WEO 2014 / DLR calculations for Reference and E[R] case (2015).

**FIGURE 11.23 | AVERAGE GLOBAL ENERGY INTENSITIES PER WORLD REGION – FINAL ENERGY PER CAPITA IN THE ENERGY [R]EVOLUTION SCENARIO**



source IEA WEO 2014 / DLR calculations for Reference and E[R] case (2015).

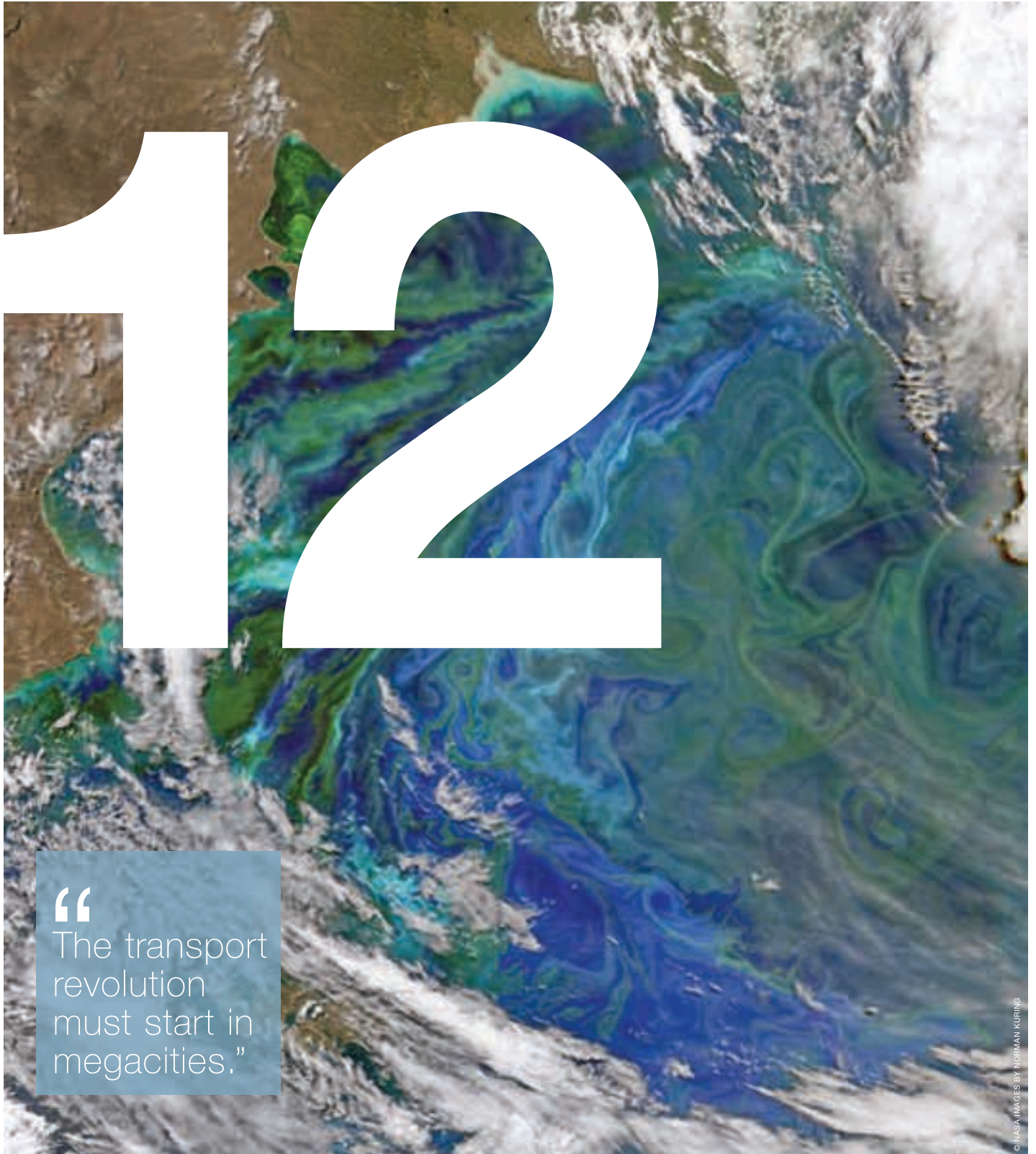
# TRANSPORT

THE FUTURE OF THE TRANSPORT  
SECTOR IN THE REFERENCE  
SCENARIO

TECHNICAL AND BEHAVIOURAL  
MEASURES TO REDUCE TRANSPORT  
ENERGY CONSUMPTION

PROJECTION OF THE  
FUTURE CAR MARKET

CONCLUSION



12

“  
The transport  
revolution  
must start in  
megacities.”

**IMAGE** LATE SPRING AND SUMMER WEATHER BRINGS BLOOMS OF COLOR TO THE ATLANTIC OCEAN OFF OF SOUTH AMERICA, AT LEAST FROM A SATELLITE VIEW. THE PATAGONIAN SHELF BREAK IS A BIOLOGICALLY RICH PATCH OF OCEAN WHERE AIRBORNE DUST FROM THE LAND, IRON-RICH CURRENTS FROM THE SOUTH, AND UPWELLING CURRENTS FROM THE DEPTHS PROVIDE A BOUNTY OF NUTRIENTS FOR THE GRASS OF THE SEA—PHYTOPLANKTON. IN TURN, THOSE FLOATING SUNLIGHT HARVESTERS BECOME FOOD FOR SOME OF THE RICHEST FISHERIES IN THE WORLD.

Sustainable transport is needed to reduce the level of greenhouse gases in the atmosphere, just as much as a shift to renewable electricity and heat production. Today, the transport sector requires just over one fourth (27%) (IEA WEO SR 2015)<sup>1</sup> of current energy use, including road and rail, aviation and sea transport. By the end of 2013, 92.7% of all transport energy demand was provided by oil products, 2.5% from bio fuels and only 1% from electricity (IEA WEO SR 2015). A transition from fossil fuels to renewable electricity – either directly or via synthetic fuels – for the entire global transport sector is required in order to phase-out carbon emissions. This is one of the most difficult parts of the Energy [R]evolution and requires a true technical revolution. It is ambitious but nevertheless possible with currently available technologies for land-based and other transport.

14% of all fossil transport fuels are used for “bunker fuel,” meaning transport energy for international shipping and international air transport. In order to replace bunker fuels entirely with renewables, a combination of energy efficiency and renewable fuels is required. Both the marine and aviation sector can start this transition, but we need more research and development along the way towards a truly 100% renewable system. Biofuels and synthetic hydrocarbons (synfuels) – produced with renewable electricity – are the only realistic renewable energy option for planes currently and for the next decade. For ships, new wind-based drives, such as new generation sails and Flettner rotors, are needed to replace a proportion of engine fuels.

The transport [R]evolution however must start in (mega)cities where a modular shift from individual to efficient and convenient public transport systems powered by renewable electricity is possible in a short time frame and with currently available technologies. Political action is the main barrier in changing land-based transport systems.

In order to assess the present status and potential technological pathways of global transport, including its carbon footprint, a special study about technical efficiency potentials and the effect of modular shifts in the transport sector was undertaken for the 2012 Energy [R]evolution report by the German Aerospace Center’s (DLR) Institute of Vehicle Concepts (DLR 2012)<sup>2</sup> analyzing the entire global transport sector based on the ten IEA world regions. The Institute carried out new technical research for Greenpeace in early 2015, focusing on the latest developments of land-based transport systems, especially for megacities (DLR 2015).<sup>3</sup> The resulting key parameters of this study are shown in Table 12.7.

The demand projections for both Energy [R]evolution scenarios are based on the afore-mentioned research work. The scenario base year has been updated using the 2014 IEA Energy Balances. The projections of the transport sector in the Reference scenario are based on IEA WEO 2014. Assumed parameters for person and freight kilometres, occupancy rates and vehicle market development have not been re-calculated but adapted to the new base year 2012 as opposed to 2009 in the previous report.

The Advanced Energy [R]evolution scenario starts with the same technical and modal shift pathways but introduces them more quickly and to a larger extent. In addition, the Advanced scenario replaces almost the entire remaining fossil fuel demand with synfuels, hydrogen and renewable methane produced from renewables from 2035 onwards. Thus, the electricity demand in the Advanced Energy [R]evolution is significantly higher.

This chapter provides an overview of selected measures appropriate to develop a more energy efficient and sustainable transport system in the future, with a focus on:

- reducing transport demand,
- shifting transport ‘modes’ (from high to low energy intensity), and
- improving energy efficiency from technology development.

The section provides plausible transport energy demand calculations including projections for the passenger vehicle market (light duty vehicles) used as background knowledge for the updated Energy [R]evolution transport pathways.

Overall, some technologies will have to be adapted for greater energy efficiency. In other situations, a simple modification will not be enough. The transport of people in megacities and urban areas will have to be reorganised almost entirely and individual transport must be complemented or even substituted by public transport systems. Car sharing and public transport on demand are only the beginning of the transition needed for a system that carries more people more quickly and conveniently to their destination while using less energy.

## REFERENCES

- 1 (IEA-WEO SR 2015); WORLD ENERGY OUTLOOK – SPECIAL REPORT 2015, INTERNATIONAL ENERGY AGENCY; JUNE 2015.
- 2 (DLR 2012); PROJECT REPORT – TRANSPORT SCENARIO BUILDING IN THE E[R] 2012. PAGENKOPF, J., SCHMID, S., FRIESKE, B., GERMAN AEROSPACE CENTER (DLR), INSTITUTE OF VEHICLE CONCEPTS; STUTTGART, GERMANY.
- 3 (DLR 2015); PROJECT REPORT – ALTERNATIVE TRANSPORT TECHNOLOGIES FOR MEGACITIES; GERMAN AEROSPACE CENTER (DLR), INSTITUTE OF VEHICLE CONCEPTS; STUTTGART, GERMANY.

## 12.1 THE FUTURE OF THE TRANSPORT SECTOR IN THE REFERENCE SCENARIO

As for electricity projections, a detailed Reference scenario is required for transport. The scenario constructed includes detailed market shares and energy intensity data per mode of transport and per region up to 2050 (sources: WBSCD, EU studies). Based on the Reference scenario, deviating transport performance and technical parameters are applied to create both Energy[R]evolution scenarios for reducing energy consumption. Traffic performance is assumed to decline for the high energy intensity modes and further energy reduction potentials were assumed from further efficiency gains, alternative power trains and fuels. The Advanced Energy [R]evolution introduces electric mobility faster and replaces all remaining fossil fuels between 2040 and 2050 with renewable synfuels, especially in the marine and aviation transport sectors.

The total transport energy demand is made up of light duty vehicles (LDVs), heavy and medium duty freight trucks, rail, air, and national marine transport (inland navigation). Although energy use from international marine bunkers (international shipping fuel suppliers) is not included in these calculations, it is still estimated to account for 14% of today's worldwide transport final energy demand and around 15% by 2050 in the Reference scenario. A UN report concluded that carbon dioxide emissions from shipping are much greater than initially thought and increasing at an alarming rate (Eyring et al 2005).<sup>4</sup> It is therefore very important to improve the energy efficiency of international shipping. Possible options are examined later in this chapter.

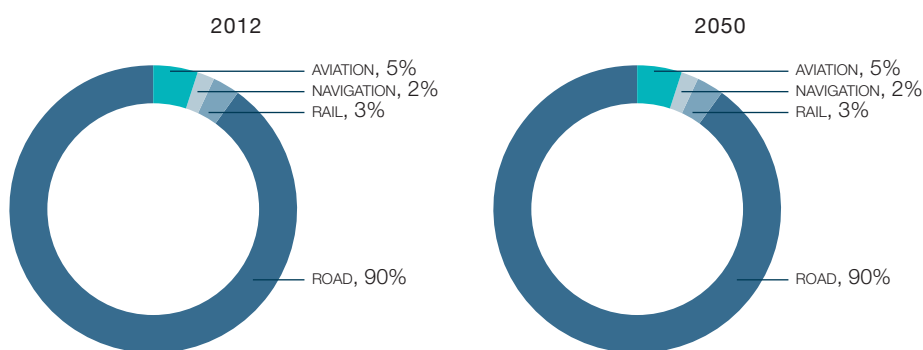
The definitions of the transport modes for the scenarios are: (Fulton 2004)<sup>5</sup>

- Light duty vehicles (LDV) are four-wheel vehicles used primarily for personal passenger road travel. These are typically cars, Sports Utility Vehicles (SUVs), small passenger vans (up to eight seats) and personal pickup trucks. Light Duty Vehicles are also simply called 'cars' within this chapter.
- Heavy Duty Vehicles (HDV) are long-haul trucks operating almost exclusively on diesel fuel. These trucks carry large loads with lower energy intensity (energy use per tonne-kilometre of haulage) than Medium Duty Vehicles, such as delivery trucks.
- Medium Duty Vehicles (MDV) include medium-haul trucks and delivery vehicles.
- Aviation in each region denotes domestic air travel (intra-regional and international air travel is provided as one figure).
- Inland navigation denotes freight shipping with vessels operating on rivers and canals or in coastal areas for domestic transport purposes

Figure 12.1 shows the breakdown of worldwide final energy demand for the transport modes in 2012 and 2050 in the Reference scenario. The largest share of energy demand comes from LDV (mainly for passenger road transport), although it decreases from 71% in 2012 to 68% in 2050. The share of domestic air transport increases from 4.6% to 5.1%. Of particular note is the high share of road transport in total transport energy demand: 87% in 2012 and 82% in 2050.

Overall energy demand in the transport sector adds up to 90 EJ in 2012. It is projected in the Reference scenario to increase to 150 EJ in 2050.

FIGURE 12.1 | WORLD FINAL ENERGY USE PER TRANSPORT MODE 2012 – 2050 – REFERENCE SCENARIO



### REFERENCES

- 4 (EYRING ET AL 2005) EYRING, V., KÖHLER, H., LAUER, A., LEMPER, B. (2005): EMISSIONS FROM INTERNATIONAL SHIPPING: 2. IMPACT OF FUTURE TECHNOLOGIES ON SCENARIOS UNTIL 2050, JOURNAL OF GEOPHYSICAL RESEARCH, 110, D17305.  
5 (FULTON 2004); FULTON, L. AND EADS, G. (2004): IEA/SMP MODEL DOCUMENTATION AND REFERENCE CASE PROJECTION, PUBLISHED BY WBSCD.



In the Advanced Energy [R]evolution scenario, implying the implementation of all efficiency and behavioural measures described, we calculated in fact a decrease of energy demand to 70 EJ, which means a lower annual energy consumption than in 2012.

Figure 12.2 shows world final energy use for the transport sector per region in 2012 and 2050 in the Reference scenario. Today, energy consumption is comprised by nearly

half of the total amount by OECD North America and OECD Europe. In 2050, the picture looks more fragmented. In particular, China and India form a much bigger portion of the world transport energy demand, whereas OECD North America remains the largest energy consumer.

## 12.2 TECHNICAL AND BEHAVIOURAL MEASURES TO REDUCE TRANSPORT ENERGY CONSUMPTION

The following section first describes how the transport modes contribute to total and relative energy demand. Next, selections of measures for reducing total and specific energy transport consumption are put forward for each mode. Measures are grouped as either behavioural or technical.

The three ways to decrease energy demand in the transport sector examined are:

- reduction of transport demand of high energy intensity modes
- modal shift from high energy intensive transport to low energy intensity modes
- energy efficiency improvements.

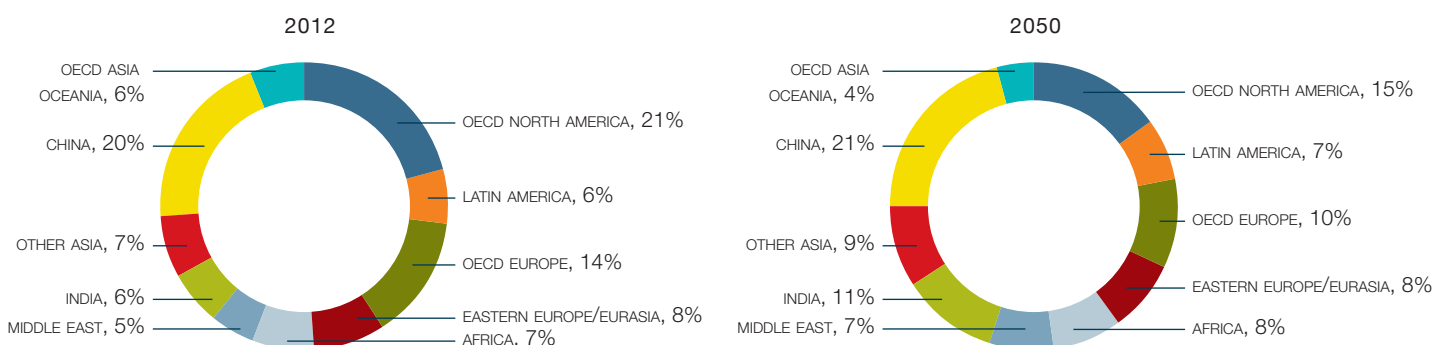
### 12.2.1 BEHAVIOURAL MEASURES TO REDUCE TRANSPORT ENERGY DEMAND

Understanding people and behaviour is the key. Sustainability is about our lifestyle choices. It is about how people live their daily lives and, as humans, how we base our decisions on our surrounding environment. Most people make decisions based on what is convenient and inviting. The Energy [R]evolution transport pathways do not rely on the very few idealists who always do 'the right thing'. Therefore, cities in particular have to change so that making the 'right choice' will be also the 'easiest choice.'

TABLE 12.1 | SELECTION OF MEASURES AND INDICATORS

MEASURE	REDUCTION OPTION	INDICATOR
REDUCTION OF TRANSPORT DEMAND	REDUCTION IN VOLUME OF PASSENGER TRANSPORT IN COMPARISON TO THE REFERENCE SCENARIO	PASSENGER-KM/CAPITA
	REDUCTION IN VOLUME OF FREIGHT TRANSPORT IN COMPARISON TO THE REFERENCE SCENARIO	TONNNE-KM/UNIT OF GDP
MODAL SHIFT	MODAL SHIFT FROM TRUCKS TO RAIL	MJ/TONNE-KM
	MODAL SHIFT FROM CARS TO PUBLIC TRANSPORT	MJ/PASSENGER-KM
ENERGY EFFICIENCY IMPROVEMENTS	SHIFT TO ENERGY EFFICIENT PASSENGER CAR DRIVE TRAINS (BATTERY ELECTRIC VEHICLES, HYBRID AND FUEL CELL HYDROGEN CARS) AND TRUCKS (FUEL CELL HYDROGEN, BATTERY ELECTRIC, CATENARY OR INDUCTIVE SUPPLIED)	MJ/PASSENGER-KM, MJ/TONNE-KM
	SHIFT TO POWERTRAIN MODES THAT MAY BE FUELLED BY RENEWABLE ENERGY (ELECTRIC, FUEL CELL HYDROGEN)	MJ/PASSENGER-KM, MJ/TONNE-KM
	AUTONOMOUS EFFICIENCY IMPROVEMENTS OF LDV, HDV, TRAINS, AIRPLANES OVER TIME	MJ/PASSENGER-KM, MJ/TONNE-KM

FIGURE 12.2 | WORLD FINAL ENERGY USE BY REGION 2012 – 2050 – REFERENCE SCENARIO



**Greenpeace promotes sustainable mobility via three different approaches:**

1. Avoid: Avoid transport where it is not necessary by embracing the ‘compact city’ model.
2. Shift: Encourage the use of more sustainable transport (such as public transport, walking, cycling) and discourage usage of private motorized transport.
3. Improve: The least efficient modes of transport (such as private cars) have to become as efficient as possible.

The point of departure for an urban mobility strategic concept that promotes sustainable mobility is the quality of the public realm, with its streets and spaces that stimulate sustainable mobility choices to contribute to quality of life – safe, economical, sustainable, inclusive (Greenpeace Germany 2015):<sup>6</sup>

- reduction of car dependency
- sustainable transportation modes
- more efficient land use by density
- mixed-use development that form mixed-modal urban hubs that are easily accessible destination points.

**12 Technical measures – urban electric mobility**

Currently, to achieve a locally emission-free land transport option, electric motors are utilized as the main powertrain. The electricity may be provided to the electric motor via several means either on or off-board:

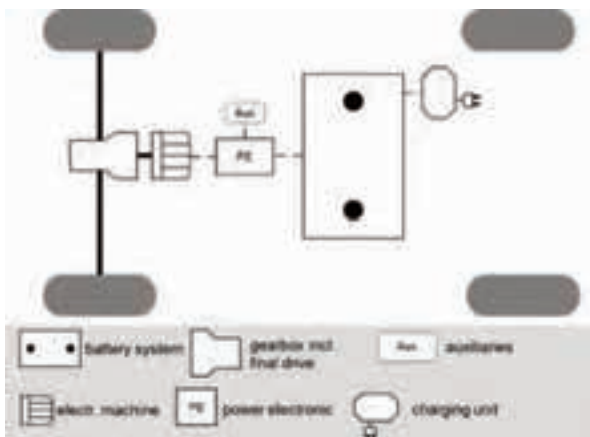
- Battery electric powertrain: The electricity is generated off-board and stored on-board via electro-chemical energy storage units,
- Catenary electric powertrain: The electricity is generated off-board and constantly supplied to the vehicle via an external catenary during driving,
- Fuel cell electric powertrain: The electricity is generated on-board with a fuel cell via reaction of hydrogen and oxygen

**Battery electric powertrain**

A battery electric vehicle (BEV) utilizes an electric motor to convert electrical energy into mechanical energy and requires a battery for the energy storage. The battery is connected to electric motor via a DC/AC converter including a control system (Grunditz, 2014).<sup>7</sup> Most of the BEVs have a gearbox with only one gear ratio (Lienkamp, 2014).<sup>8</sup> If the vehicle has only one central electric motor, then a differential is needed similar to those in conventional vehicles. The structure of a BEV with a central electric motor is presented schematically in Figure 12.3.

The battery is considered to be one of the most critical components of electrified vehicles due to its cost-intensive nature. Furthermore, batteries have lower energy density resulting in limited driving ranges combined with high volumes and masses of the energy storage system. Therefore, batteries (especially lithium-based ones) have been subject to tremendous research efforts in recent years and this trend is expected to continue in the following years (Wagner, Preschitschek et al., 2013)<sup>9</sup> with improvements in costs, life expectancy and energy density.

**FIGURE 12.3 | SCHEMATIC ARCHITECTURE OF BATTERY ELECTRIC VEHICLES (BEV)**



source DLR.

**REFERENCES**

6 (GREENPEACE GERMANY 2015); GREENPEACE STRATEGY FOR GREEN MOBILITY; D. MOSER /GPD; GEHL ARCHITECTS DENMARK 2015.  
7 GRUNDITZ, E. A. (2014). BEV POWERTRAIN COMPONENT SIZING WITH RESPECT TO PERFORMANCE, ENERGY CONSUMPTION AND DRIVING PATTERNS. DEPARTMENT OF ENERGY AND ENVIRONMENT, CHALMERS UNIVERSITY OF TECHNOLOGY LICENTIATE OF ENGINEERING.

8 LIENKAMP, M. (2014). STATUS OF ELECTRICAL MOBILITY 2014  
9 WAGNER, R., N. PRESCHITSCHKEK, ET AL. (2013). "CURRENT RESEARCH TRENDS AND PROSPECTS AMONG THE VARIOUS MATERIALS AND DESIGNS USED IN LITHIUM-BASED BATTERIES." J APPL ELECTROCHEM 43: 481-496.

Several quick battery charging strategies for battery electric road and rail vehicles beyond common conductive cable-based charging have emerged in recent years (some of which have already entered commercialization):

- **Conductive quick charging:** This strategy is mainly designed for buses and trams. The charging at high power rates (200-500 kW) is performed at intermediate and turning points via extendable pantographs; a demonstration project for buses is, for example, in day-to-day use in Geneva, Switzerland (SAE Off-Highway Engineering Online, 2013).<sup>10</sup>
- **Inductive quick charging:**
  - Several research and demonstration projects on inductive charging at traffic lights or even dynamically in-road-charging exist for passenger cars (EGVI, 2014; WiCh, 2014).<sup>11</sup>
  - For buses at intermediate stops and 10-30 minutes re-charging at turning points, several research, demonstration and commercialization projects are underway operating with a charging power of 50-200 kW (FTA, 2014b).<sup>12</sup>
- **Battery swapping stations**
  - China has used robotic battery swapping stations for its urban battery electric buses in several cities since 2008 (Li, 2013).<sup>13</sup>
  - Battery car maker Tesla has installed a commercial battery swap station in California allowing a battery swap in about 3 minutes (Forbes, 2014).<sup>14</sup>
- Both inductive charging at stations and battery swap stations demand high infrastructural investments but enable a reduction of on-board battery capacity, weight, and hence vehicle cost (and allowing also an increase of passenger load).

Although battery-electric drivetrains could also be applied to rail applications, only road battery electric vehicles are considered in this study since external catenary systems are best suited to rail-bound urban mass rapid transit systems. The advantages of battery electric road vehicles compared to conventional internal combustion engine vehicles are summarized below:

- Zero local emissions
- Significant lower well-to-wheel greenhouse gas emissions possible (depending on the electricity generation)

**REFERENCES**

10 SAE OFF-HIGHWAY ENGINEERING ONLINE (2013). "ABB 'FLASH CHARGES' ELECTRIC BUS IN 15 S." RETRIEVED 20.01.2015, FROM [HTTP://ARTICLES.SAE.ORG/12293/](http://articles.sae.org/12293/).

11 EGVI (2014). "UNPLUGGED - INDUCTIVE CHARGING FOR ELECTRIC VEHICLES (FEBRUARY 2014)." RETRIEVED 28.01.2015, FROM [HTTP://WWW.EGVI.EU/PROJECTS/13/38/UNPLUGGED-INDUCTIVE-CHARGING-FOR-ELECTRIC-VEHICLES-FEBRUARY-2014](http://www.egvi.eu/projects/13/38/unplugged-inductive-charging-for-electric-vehicles-february-2014).

12 FTA (2014B). REVIEW AND EVALUATION OF WIRELESS POWER TRANSFER (WPT) FOR ELECTRIC TRANSIT APPLICATIONS, FTA REPORT NO. 0060, FEDERAL TRANSIT ADMINISTRATION. F. T. A. U.S. DEPARTMENT OF TRANSPORTATION.

13 LI, J. L. F. (2013). "CASE STUDY OF EV CITY BUS OPERATIONS." FROM [HTTP://BESTAR.LBL.GOV/US-CHINA-WORKSHOP-2013/FILES/2013/04/JAN-LI-LITHIUM-FORCE.PDF](http://bestar.lbl.gov/us-china-workshop-2013/files/2013/04/jan-li-lithium-force.pdf).

14 FORBES (2014). "TESLA'S BATTERY SWAP STATIONS WILL HELP IT REQUALIFY FOR ZEV CREDITS IN CALIFORNIA." RETRIEVED 20.01.2015, FROM [HTTP://WWW.FORBES.COM/SITES/GREATSPECULATIONS/2014/12/30/TESLAS-BATTERY-SWAP-STATIONS-WILL-HELP-IT-REQUALIFY-FOR-ZEV-CREDITS-IN-CALIFORNIA/](http://www.forbes.com/sites/greatspeculations/2014/12/30/teslas-battery-swap-stations-will-help-it-requalify-for-zev-credits-in-california/).

15 DEN BOER, E., S. AARNIK, ET AL. (2013). ZERO EMISSIONS TRUCKS - AN OVERVIEW OF STATE-OF-THE-ART TECHNOLOGIES AND THEIR POTENTIAL. DELFT, CE DELFT.

- Lower variable costs (mainly fuel)
- Higher torque compared to internal combustion engine at low speed
- Lower vibrations and noise

However, battery electric road vehicles have also some drawbacks compared to internal combustion engine vehicles, which include: :

- Limited driving range due to lower energy density
- Longer charging time,
- Additional infrastructure requirement for charging points
- Higher purchase costs (at the moment)

**Catenary electric powertrain**

Public transport systems, such as trams (light rail trains), metro, commuter train and trolley bus systems are operated on rail or road networks equipped with electric overhead wires or third rails alongside the track. The electric power is continuously transferred to the vehicle via the wire or third rail, usually direct current (DC) with 500 – 1500 V, and drawn by a current collector installed on the vehicle. Sometimes, also alternate current (AC) systems with higher voltages are applied in commuter rail systems. Urban tram, metro and usually also commuter rail systems draw the electricity from an overhead catenary or a third rail. Road trolley buses operate with special current collectors under two overhead wires; one is to draw the current from the wire and the other to close the circuit. In recent years, overhead catenary trucks for goods transport on roads have been in discussion (den Boer, Aarnik et al., 2013)<sup>15</sup>, but no such system has begun to enter commercial service in an urban environment up to now. Furthermore, overhead catenary trucks are not expected to be in service in the megacities in the near future (about 5 years). In general, overhead catenary systems can be distinguished by transport application as presented in Table 12.2.

**TABLE 12.2 | OVERHEAD CATENARY AND THIRD RAIL SYSTEMS IN URBAN PUBLIC TRANSPORT APPLICATIONS**

TRANSPORT APPLICATIONS	ENERGY SUPPLY SYSTEM	TYPICAL VOLTAGE LEVELS
TRAM/LIGHT RAIL		500-750 V DC
METRO	OVERHEAD CATENARY	750-1500 V DC
COMMUTER TRAIN		0.75-1.5 kV DC or 15/25 kV AC
METRO, COMMUTER TRAIN	THIRD RAIL	750-1500 V DC
TROLLEY BUS	OVERHEAD CATENARY (TWO POLES)	V DC

source DLR vehicle database.



- Zero local emissions
- Possibly lower well-to-wheel greenhouse gas emissions than internal combustion engine vehicles (depending on how the hydrogen is produced)
- High efficiency of fuel cells compared to internal combustion engine, particularly at low temperatures
- Lower vibrations and noise than conventional vehicles
- Higher range of operation than BEVs
- Significant shorter refueling times than recharging times for BEVs

However, fuel cell electric road vehicles have also some drawbacks, which include:

- Higher purchase costs (even higher than BEVs)
- Requirement to build a hydrogen infrastructure
- High purity requirements and high cost of hydrogen as fuel
- Durability and long-term performance of fuel cell stack especially for transient operation

#### STEP 1: REDUCTION OF TRANSPORT DEMAND

To use less transport overall means reducing the amount of 'passenger-km (p-km)' travelled per capita and reducing freight transport demand. The amount of freight transport is to a large extent linked to GDP development and therefore difficult to influence. However, improved logistics – for example, optimal load profiles for trucks and a shift to regionally produced goods – can reduce transport demand.

##### Passenger transport:

The study focussed on the change in passenger km per capita of high-energy intensity air transport and personal vehicles modes. Passenger transport by light duty vehicles (LDV), for example, is energy-demanding both in absolute and relative terms. Policy measures that enforce a reduction of passenger km travelled by individual transport modes are an effective means to reduce transport energy demand. Policy measures for reducing passenger transport demand in general could include:

- charge and tax policies that increase transport costs for individual transport
- price incentives for using public transport modes
- installation or upgrading of public transport systems
- incentives for working from home
- stimulating the use of video conferencing in business
- improved cycle paths in cities.

In the Reference scenario, there is a forecast increase in passenger-km in all regions up to 2050. For the 2050 Energy [R]evolution scenario, there is still a rise, but it would be much flatter. For OECD Europe and OECD North America there will even be a decline in individual transport on a per capita basis.

The reduction in passenger-km per capita in the Advanced Energy [R]evolution scenario compared to the Reference scenario comes with a general reduction in car use due to behavioural and traffic policy changes and partly with a shift of transport to public modes.

A shift from energy-intensive individual transport to low-energy demand public transport goes along with an increase in low-energy public transport person-km.

##### Freight transport:

It is difficult to estimate a reduction in freight transport. Neither Energy [R]evolution scenario includes a model for reduced volume for required freight transport, but it is assumed that a modal shift from road to rail and/or to battery or fuel cell power transport vehicles takes place.

#### STEP 2: CHANGES IN TRANSPORT MODE

Determining which vehicles and transport modes are the most efficient for each purpose requires an analysis of the transport mode technologies. Then, the energy use and intensity of each type of transport is used to calculate energy savings resulting from a transport mode shift. The following information is required:

- Passenger transport: Energy demand per passenger kilometer, measured in MJ/p-km.
- Freight transport: Energy demand per kilometre of transported tonne of goods, measured in MJ/tonne-km.

For this study, passenger transport includes light duty vehicles, passenger rail and air transport. Freight transport includes medium duty vehicles, heavy duty vehicles, inland navigation, marine transport and freight rail. WBCSD 2004 data was used in (DLR 2012) as baseline data and updated where more recent information was available.

##### Passenger transport:

Travelling by rail is the most efficient – but car transport improves strongly. Figure 12.5 shows the worldwide average specific energy consumption (energy intensity) by transport mode in the base year and in the Energy [R]evolution scenario in 2050. This data differs for each region. There is a large difference in specific energy consumption among the transport modes. Passenger transport by rail will consume 28% less energy in 2050 than car transport and 85% less than aviation on a per p-km basis, so shifting from road to rail can produce large energy savings.

From Figure 12.5, we can conclude that passengers will need to shift from cars and especially air transport to less energy-intensive passenger rail transport in order to reduce transport energy demand.

The Energy [R]evolution scenario assumes that a certain proportion of passenger-kilometer of domestic air traffic and intraregional air traffic (i. e., traffic among two countries of one IEA region) is suitable to be substituted by high speed rail (HSR). For international aviation, there is obviously no substitution potential to other modes whatsoever.

Table 12.3 displays the relative model shifts used in the calculation for the Energy [R]evolution scenarios. Where the shares are higher, cities are closer to each other, so a substitution by high speed trains is a more realistic option (i. e. distances of up to 800 – 1,000 km, compared to countries where they are far apart).

**Freight transport:**

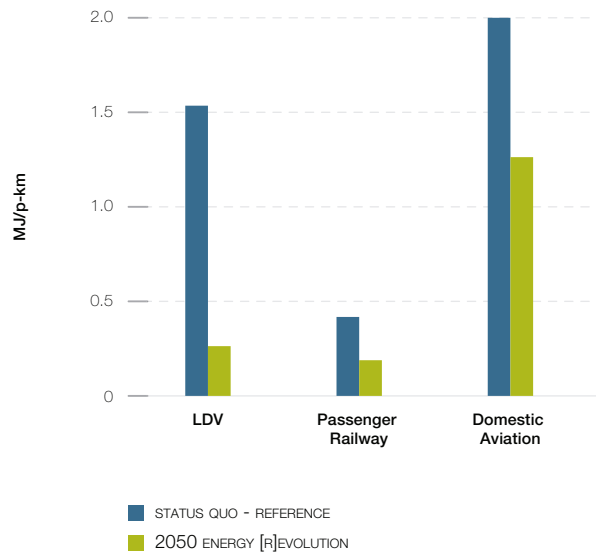
Similar to Figure 12.5, which showed average specific energy consumption for passenger transport modes, Figure 12.6 shows the respective energy consumption for various freight transport modes in 2009 and in Energy [R]evolution scenarios 2050, the values are weighted according to stock and traffic performance.

12 Energy intensity for all modes of transport is expected to decrease by 2050. In absolute terms, road transport has the largest efficiency gains whereas transport on rail and on water remain the modes with the lowest relative energy demand per tonne-km. Rail freight transport will consume 80-90% less energy per tonne-km in 2050 than long haul HDV. This means that large energy savings can be made following a shift from road to rail.

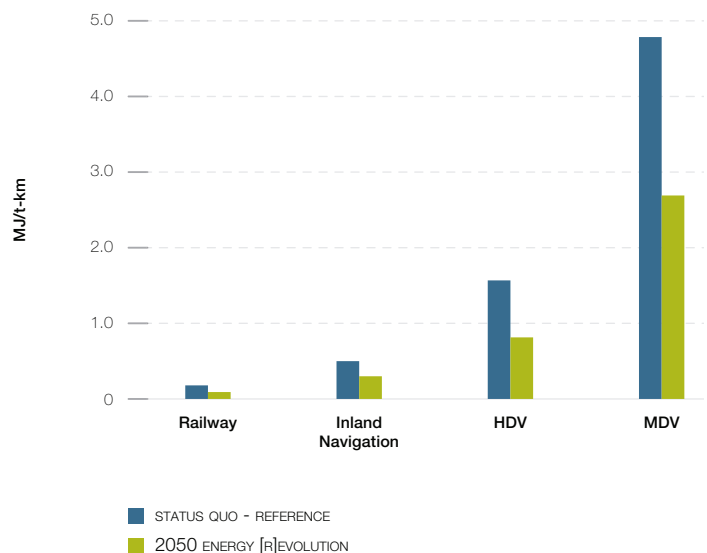
**TABLE 12.3 | AIR TRAFFIC SUBSTITUTION POTENTIAL OF HIGH SPEED RAIL (HSR)<sup>17</sup>**

REGION	RELATIVE SUBSTITUTION OF AIR TRAFFIC TO HSR IN 2050	
	DOMESTIC	INTRAREGIONAL
OECD EUROPE	30 %	15 %
OECD NORTH AMERICA	20 %	10 %
OECD ASIA OCEANIA	20 %	10 %
LATIN AMERICA	30 %	10 %
OTHER (NON OECD) ASIA	20 %	10 %
EASTERN EUROPE/EURASIA	10 %	10 %
CHINA	20 %	10 %
MIDDLE EAST	30 %	10 %
INDIA	20 %	10 %
AFRICA	20 %	10 %

**FIGURE 12.5 | WORLD AVERAGE (STOCK-WEIGHTED) PASSENGER TRANSPORT ENERGY INTENSITIES FOR TODAY AND 2050<sup>18</sup>**



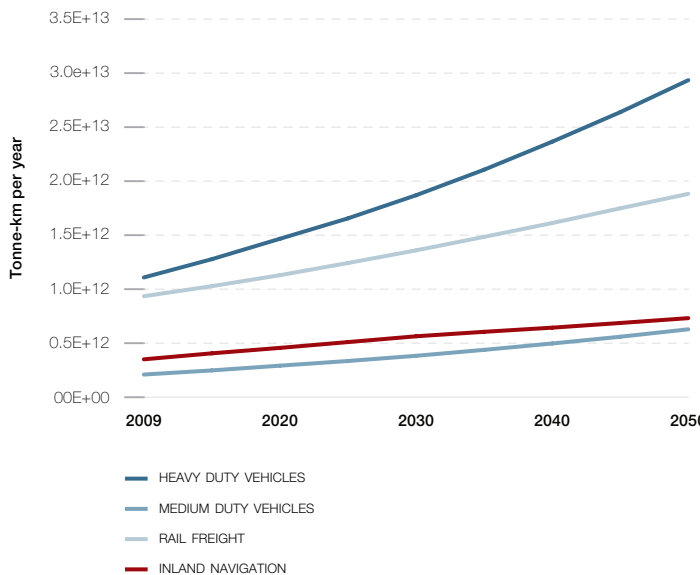
**FIGURE 12.6 | WORLD AVERAGE (STOCK-WEIGHTED) FREIGHT TRANSPORT ENERGY INTENSITIES FOR TODAY AND 2050<sup>17</sup>**



**REFERENCES**

<sup>18</sup> ACCORDING TO (DLR 2012) FOR THE 2012 EDITION OF ENERGY [R]EVOLUTION – THE ADVANCED ENERGY [R]EVOLUTION INTRODUCES THE SAME EFFICIENCY TECHNOLOGIES FASTER.

**FIGURE 12.7 | DEVELOPMENT OF TONNE-KM OVER TIME IN THE REFERENCE SCENARIO** <sup>17</sup>



- air transport
- passenger and freight trains
- trucks
- inland navigation and marine transport
- cars

In general, an integral part of an energy reduction scheme is an increase in the load factor – both for freight and passenger transport. As the load factor increases, fewer vehicles need to be employed, so the energy intensity decreases when measured per passenger-km or tonne-km.

In aviation, there are already sophisticated efforts to optimise the load factor; however, for other modes such as road and rail freight transport there is still room for improvement. For freight transport, logistics and supply chain planning can improve load factors, while enhanced capacity utilisation will do so in passenger transport.

#### Air transport

A study conducted by NASA (NASA 2011)<sup>20</sup> shows that the energy use of new subsonic aircrafts can be reduced by up to 58% up to 2035. Potentially, up to 81% reductions in CO<sub>2</sub> emissions are achievable when using biofuels. (Akerman 2005)<sup>21</sup> reports that a 65% reduction in fuel use is technically feasible by 2050. Technologies to reduce fuel consumption of aircrafts mainly comprise:

- Aerodynamic adaptations to reduce the drag of the aircraft, for example by improved control of laminar flow, the use of riblets and multi-functional structures, the reduction in fasteners, flap fairings and the tail size as well as advanced supercritical airfoil technologies.
- Structural technologies to reduce the weight of the aircraft while at the same time increasing stiffness. Examples include the use of new lightweight materials like advanced metals, composites and ceramics, the use of improved coatings, and the optimised design of multi-functional, integrated structures.
- Subsystem technologies, including advanced power management and generation along with optimised flight avionics and wiring.
- Propulsion technologies like advanced gas turbines for powering the aircraft more efficiently, possibly including:
  - improved combustion emission measures, improvements in cold and hot section materials, and the use of turbine blade/vane technology;
  - investigation of all-electric, fuel-cell gas turbine and electric gas turbine hybrid propulsion devices;
  - electric propulsion technologies comprise advanced lightweight motors, motor controllers and power conditioning equipment (ICAO 2008).<sup>22</sup>

#### Modal shifts for transporting goods in the Energy [R]evolution

In the Energy [R]evolution scenarios, as much road freight as possible should be shifted from road freight transport to less energy intensive freight rail to gain maximum energy savings from modal shifts.

Since the use of ships largely depends on geography, a modal shift is not proposed for national ships but instead a shift towards freight rail. As the goods transported by medium duty vehicles are mainly going to regional destinations (and are therefore not suitable for the long distance nature of freight rail transport), no modal shift to rail is assumed for this transport type.

For long-haul heavy duty vehicles transport, however, especially low value density, heavy goods that are transported on a long range are suitable for a modal shift to railways (Tavasszy 2011).<sup>19</sup>

#### STEP 3: TECHNICAL EFFICIENCY IMPROVEMENTS

Energy efficiency improvements are the third important way of reducing transport energy demand. This section explains ways for improving energy efficiency up to 2050 for each type of transport, namely:

#### REFERENCES

- (TAVASSZY 2011); TAVASSZY, L. AND VAN MEIJEREN, J. (2011): MODAL SHIFT TARGET FOR FREIGHT TRANSPORT ABOVE 300 KM: AN ASSESSMENT, DISCUSSION PAPER, 17TH ACEA SAG MEETING.
- (NASA 2011) BRADLEY, M. AND DRONEY, C. (2011): SUBSONIC ULTRA GREEN AIRCRAFT RESEARCH: PHASE I FINAL REPORT, ISSUED BY NASA.
- (AKERMAN 2005) AKERMAN, J. (2005): SUSTAINABLE AIR TRANSPORT - ON TRACK IN 2050. TRANSPORTATION RESEARCH PART D, 10, 111-126.
- (ICAO 2008): COMMITTEE ON AVIATION ENVIRONMENTAL PROTECTION (CAEP), STEERING GROUP MEETING, FESG CAEP/8 TRAFFIC AND FLEET FORECASTS.

The scenario projects a 50% improvement in specific energy consumption on a per passenger-km basis for future aircrafts in 2050 based on today's energy intensities. Figure 12.8 shows the energy intensities in the Energy [R]evolution scenario for international, intraregional and domestic aviation.

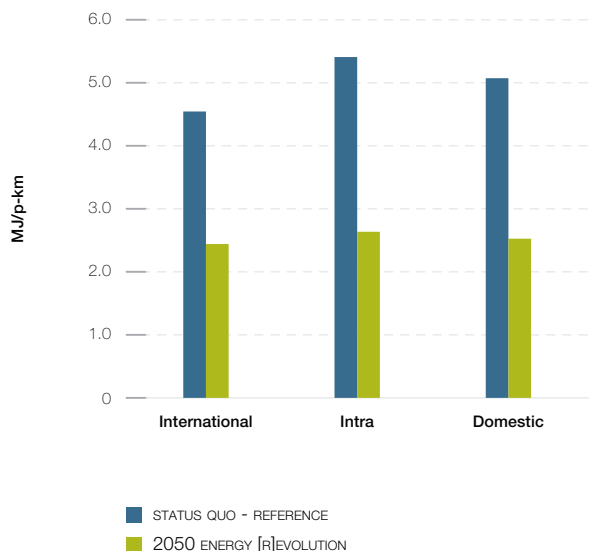
Finally Figure 12.9 shows the final energy consumption by technologies in the reference and in both Energy [R]evolution scenarios.

### Passenger and freight trains

Transport of passengers and freight by rail is currently one of the most energy efficient means of transport. However, there is still potential to reduce the specific energy consumption of trains. Apart from operational and policy measures to reduce energy consumption like raising the load factor of trains, technological measures to reduce energy consumption of future trains are necessary, too. Key technologies are:

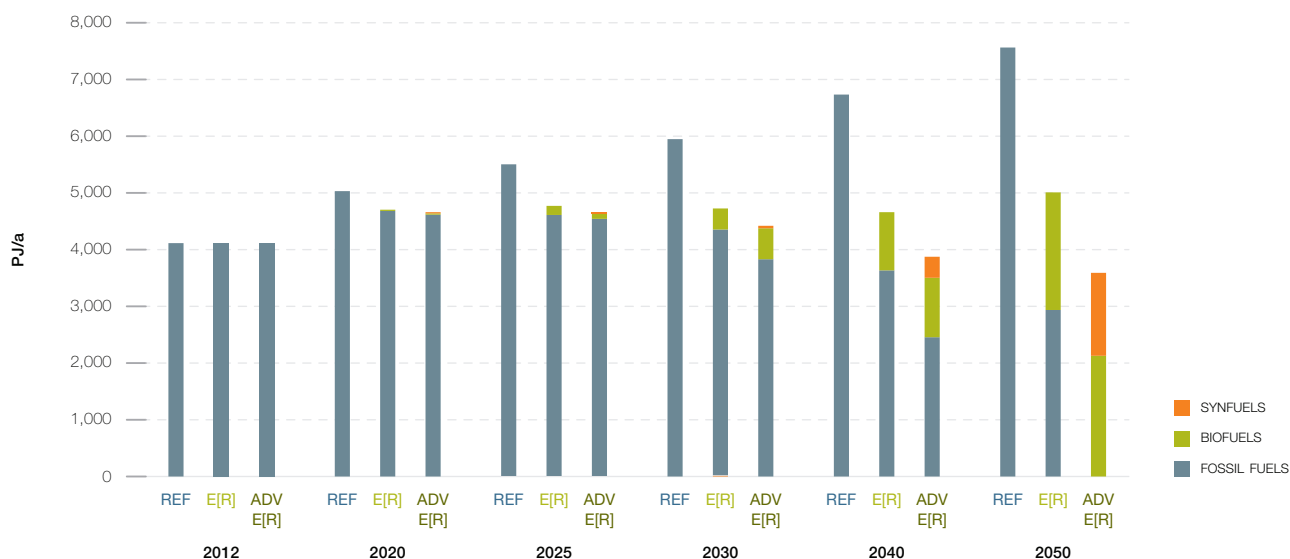
- reducing the total weight of a train as the most significant measure to reduce traction energy consumption. By using lightweight structures and lightweight materials, the energy needed to overcome inertial and grade resistances as well as friction from tractive resistances can be reduced.
- aerodynamic improvements to reduce aerodynamic drag, especially important when running on high velocity. A reduction of aerodynamic drag is typically achieved by streamlining the profile of the train.

**FIGURE 12.8 | ENERGY INTENSITIES (MJ/P-KM) FOR AIR TRANSPORT IN ENERGY [R]EVOLUTION SCENARIOS**



note All regions have the same energy intensities due to a lack of regionally differentiated data. Numbers shown are the global average.

**FIGURE 12.9 | DEVELOPMENT OF FINAL ENERGY USE FOR AVIATION BY TECHNOLOGIES IN THE REFERENCE AND BOTH ENERGY [R]EVOLUTION SCENARIOS**





- switch from diesel-fuelled to more energy efficient electrically driven trains.
- improvements in the traction system to further reduce frictional losses. Technical options include improvements of the major components and in energy management software.
- regenerative braking to recover waste energy. The energy can either be transferred back into the grid or stored on-board in an energy storage device. Regenerative braking is especially effective in regional traffic with frequent stops.
- improved space utilisation to achieve more efficient energy consumption per passenger kilometre. The simplest way to achieve this is to transport more passengers per train – in other words, by a higher average load factor, more flexible and shorter trainsets or by the use of double-decker trains on highly frequented routes.
- improved accessory functions, such as for passenger comfort. A high energy efficiency potential lies in the new design of heating and cooling equipment. Some strategies for efficiency include adjustments to cabin design, changes to air intakes, and using waste heat from traction.

By researching technologies for advanced high-speed trains, the DLR's 'Next Generation Train' project aims to reduce the specific energy consumption per passenger-kilometre by 50% relative to existing high speed trains in the future.

The Energy [R]evolution scenario uses energy intensity data of (TOSCA 2011)<sup>23</sup> for electric and diesel fuelled trains in Europe as input for our calculations. These data were available for 2009 and as forecasts for 2025 and 2050.

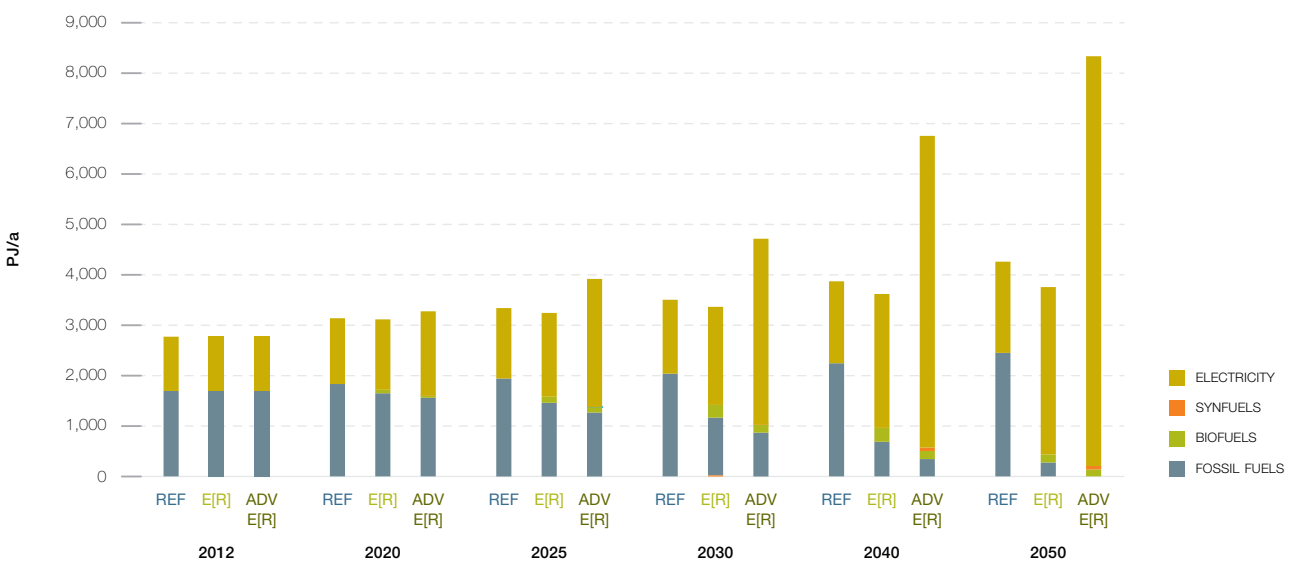
The region-specific efficiency factors and shares of diesel/electric traction traffic performance were used to calculate energy intensity data per region (MJ/p-km) for 2012 and up to 2050. The same methodology was applied for rail freight transport.

Electric trains as of today are about 2 to 3.5 times less energy-intensive than diesel trains depending on the specific type of rail transport, so the projections to 2050 include a massive shift away from diesel to electric traction in the Energy [R]evolution 2050 scenario.

The region-specific efficiency factors for passenger rail take into account higher load factors, for example in China and India. Energy intensity for freight rail is based on the assumptions that regions with longer average distances for freight rail (such as the US and Russia) and where more raw materials are transported (such as coal) show a lower energy intensity than other regions (Fulton & Eads 2004).<sup>24</sup> Future projections use ten-year historic IEA data.

The calculation of possible future development in the rail transport sector under the described assumption leads to the results shown in Figure 12.14. Under the Energy [R]evolution scenarios over 90% of all rail lines are electrified by 2040.

**FIGURE 12.10 | DEVELOPMENT OF FINAL ENERGY USE FOR RAIL TRANSPORT BY TECHNOLOGIES IN THE REFERENCE AND BOTH ENERGY [R]EVOLUTION SCENARIOS**



**REFERENCES**

<sup>23</sup> TOSCA (2011): TECHNOLOGY OPPORTUNITIES AND STRATEGIES TOWARD CLIMATE-FRIENDLY TRANSPORT (REPORTS).  
<sup>24</sup> (FULTON & EADS 2004); FULTON, L. AND G. EADS. (2004) IEA/SMP MODEL DOCUMENTATION AND REFERENCE CASE PROJECTION. WORLD BUSINESS COUNCIL FOR SUSTAINABLE DEVELOPMENT (WBCSD).  
[HTTP://WWW.WBCSD.ORG/WEB/PUBLICATIONS/MOBILITY/SMP-MODEL-DOCUMENT.PDF](http://www.wbcSD.org/web/publications/mobility/smp-model-document.pdf).

### Heavy and medium duty vehicles (freight by road)

Freight transport on the road forms the backbone of logistics in many regions of the world. But apart from air freight transport, it is the most energy-intensive way of moving goods around. However, gradual progress is being made in the fields of drivetrain efficiency, lightweight construction, alternative power trains and fuels and so on.

This study projected a major shift in drivetrain market share of medium (MDV) and heavy duty vehicles (HDV) in the Energy [R]evolution scenarios in the future. Today, the great majority of MDVs and HDVs have internal combustion engines, fuelled mainly by diesel and in MDV also by a small share of gasoline and gas (CNG and LPG). The Energy [R]evolution model includes a major shift to electric and fuel cell hydrogen-powered vehicles (FCV) by 2050.

The electric MDV stock in the model developed by (DLR 2012) is mainly composed of battery electric vehicles (BEV), and a relevant share of hybrid electric vehicles (HEV). Hybrid electric vehicles will have also displaced conventional internal combustion engines in heavy duty vehicles. In addition to this, both electric vehicles supplied with current via overhead catenary lines and BEVs are modelled in the Energy [R]evolution scenario for HDV applications.

Siemens has proved the technical feasibility of the catenary technology for trucks with experimental vehicles in its eHighway project. The trucks are equipped with a hybrid diesel powertrain to be able to operate when not connected to the overhead line. When under a catenary line, the trucks can operate fully electric at speeds of up to 90 km/h. Apart from electrically operated trucks fed by an overhead catenary, inductive power supply via induction loops under the pavement could become an option.

In addition to the electric truck fleet in the Energy [R]evolution scenario, HDV and MDV powered by fuel cells (FCV) were integrated into the vehicle stock, too. FCV are beneficial especially for long haul transports where no overhead catenary lines are available and the driving range of BEV would not be sufficient.

Energy [R]evolution fleet average transport energy intensities for MDV and HDV were derived using region-specific IEA energy intensity data of MDV and HDV transport by 2050 (WBSCD 2004),<sup>25</sup> with the specific energy consumption factors of Table 12.4 applied to the IEA data and matched with the region-specific market shares of the power train technologies.

The reduction between the current situation and 2050 in the Advanced Energy [R]evolution on a per tonne-km basis is then 50-60% for MDV and HDV.

**TABLE 12.4 | THE WORLD AVERAGE ENERGY INTENSITIES FOR MDV AND HDV CURRENTLY AND 2050 ENERGY [R]EVOLUTION SCENARIO<sup>17</sup>**

	STATUS QUO	E[R] 2050
MDV	5,02 MJ/T-KM	2,18 MJ/T-KM
HDV	1,53 MJ/T-KM	0,74 MJ/T-KM

#### REFERENCES

<sup>25</sup> (WBSCD 2004) WORLD BUSINESS COUNCIL FOR SUSTAINABLE DEVELOPMENT.

The DLR's Institute of Vehicle Concepts conducted special studies to look at future vehicle concepts to see what the potential might be for reducing the overall energy consumption of existing and future trucks when applying energy efficient technologies (DLR 2012)/(DLR 2015). The approach shows the potential of different technologies influencing the energy efficiency of future trucks and also indicates possible cost developments.

### Inland Navigation

Technical measures to reduce energy consumption of inland vessels include (van Rompuy 2010)<sup>26</sup>:

- aerodynamic improvements to the hull to reduce friction resistance
- improving the propeller design to increase efficiency
- enhancing engine efficiency.

For inland navigation, we assumed a reduction of 40% of global averaged energy intensity to 0.3 MJ/t-km from the current value of 0.5 MJ/t-km.

### Marine Transport

Several technological measures can be applied to new vessels in order to reduce overall fuel consumption in national and international marine transport. These technologies are, for example:

- weather routing to optimise the vessel's route
- autopilot adjustments to minimise steering
- improved hull coatings to reduce friction losses

- improved hull openings to optimise water flow
- air lubrication systems to reduce water resistances
- improvements in the design and shape of the hull and rudder
- waste heat recovery systems to increase overall efficiency
- improvement of the diesel engine (e.g. common-rail technology)
- installing new wind energy technologies such as towing kites, Flettner turbines and advanced sailing rigs to use wind energy for propulsion
- using solar energy for on-board power demand

Adding each technology effectiveness figure stated by (ICCT 2011),<sup>27</sup> these technologies have a potential to improve energy efficiency of new vessels between 18.4% and about 57%. Another option to reduce energy demand of ships is simply to reduce operating speeds. Up to 36% of fuel consumption can be saved by reducing the vessel's speed by 20%. A 25% reduction of fuel consumption for an international marine diesel fleet is achievable by using more efficient alternative propulsion devices only (Eyring et al. 2005).<sup>28</sup> Up to 30% reduction in energy demand is achievable only by optimising the hull shape and propulsion devices of new vessels (MarinTek 2000).<sup>29</sup>

The model assumes a total of 40% energy efficiency improvement potential for international shipping. In order to phase out fossil fuels entirely from marine transports, a mix of energy efficiency (including new wind drives), biofuels and synfuels powered engines are required.

**FIGURE 12.11 | DEVELOPMENT OF FINAL ENERGY USE FOR MARINE TRANSPORT BY TECHNOLOGIES IN THE REFERENCE AND BOTH ENERGY [R]EVOLUTION SCENARIOS**



### REFERENCES

- <sup>26</sup> (VAN ROMPUY 2010); GEERTS, S., VERWERFT, B., VANTORRE, M. AND VAN ROMPUY, F. (2010); IMPROVING THE EFFICIENCY OF SMALL INLAND VESSELS. PROCEEDINGS OF THE EUROPEAN INLAND WATERWAY NAVIGATION CONFERENCE.
- <sup>27</sup> (ICCT 2012); ICCT (2011); REDUCING GREENHOUSE GAS EMISSIONS FROM SHIPS – COST EFFECTIVENESS OF AVAILABLE OPTIONS.
- <sup>28</sup> (EYRING ET AL. 2005).
- <sup>29</sup> (MARINTEK 2000); STUDY OF GREENHOUSE EMISSIONS FROM SHIPS, FINAL REPORT TO THE INTERNATIONAL MARITIME ORGANIZATION.

**BOX 12.1 | CASE STUDY: WIND POWERED SHIPS**

Introduced to commercial operation in 2007, the SkySails system uses wind power, which has no fuel costs, to contribute to the motion of large freight-carrying ships, which currently use increasingly expensive and environmentally damaging oil. Instead of a traditional sail fitted to a mast, the system uses large towing kites to contribute to the ship's propulsion. Shaped like paragliders, they are tethered to the vessel by ropes and can be controlled automatically, responding to wind conditions and the ship's trajectory.

The kites can operate at altitudes of between 100 and 300 metres, where there are stronger and more stable winds. With dynamic flight patterns, the SkySails are able to generate five times more power per square metre of sail area than conventional sails. Depending on the prevailing winds, the company claims that a ship's average annual fuel costs can be reduced by 10% to 35%. Under optimal wind conditions, fuel consumption can temporarily be cut by 50%.

On the first voyage of the Beluga SkySails, a 133 m long specially-built cargo ship, the towing kite propulsion system was able to temporarily substitute for approximately 20% of the vessel's main engine power, even in moderate winds. The company is now planning a kite twice the size of this 160m<sup>2</sup> pilot.

The designers say that virtually all sea-going cargo vessels can be retro- or outfitted with the SkySails propulsion system without extensive modifications.

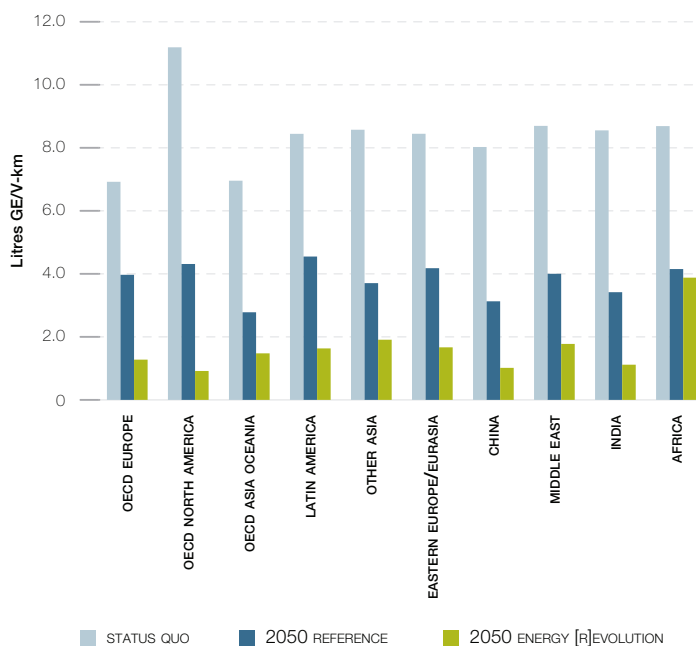
Besides Skysails, there are Flettner-rotors, new sailing rigs such as DYNARIG and other wind energy systems for ships in development. Greenpeace supports the implementation of new wind energy technologies to reduce marine fuel demand and to replace bunker fuels and demands for financial support program for research and development (R&D).

**Passenger cars**

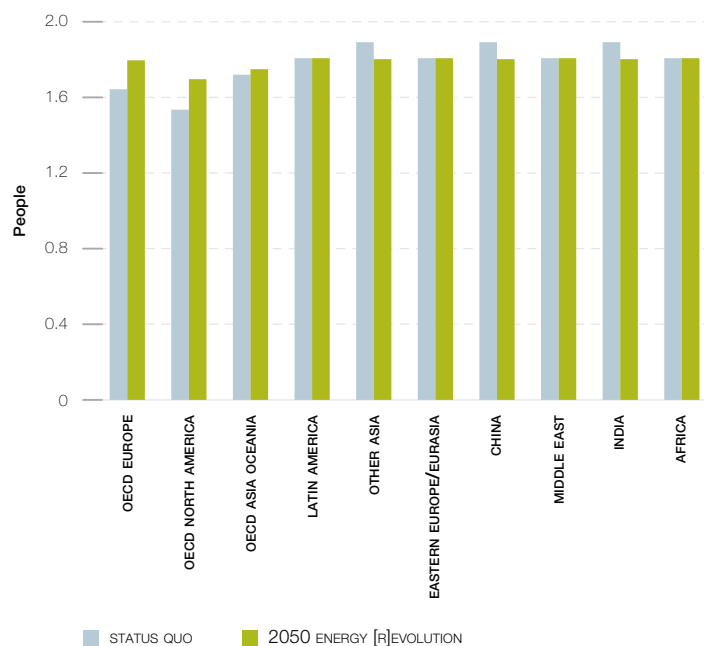
Many technologies can be used to improve the fuel efficiency of passenger cars. Examples include improvements in engines, weight reduction as well as friction and drag reduction.

The impact of the various measures on fuel efficiency can be substantial. Hybrid vehicles, combining a conventional combustion engine with an electric engine, have relatively low fuel consumption. The most well-known is the Toyota Prius, which originally had a fuel efficiency of about 5 litres of gasoline equivalent per 100 km (litre ge/100 km). In 2012, Toyota presented an improved version with a lower fuel

**FIGURE 12.12 | ENERGY INTENSITIES FOR LDV CURRENTLY AND UNDER THE ENERGY [R]EVOLUTION IN 2050<sup>17</sup>**



**FIGURE 12.13 | LDV OCCUPANCY RATES CURRENTLY AND UNDER THE ENERGY [R]EVOLUTION IN 2050<sup>17</sup>**



consumption of 4.3 litres ge/100 km. New lightweight materials, in combination with new propulsion technologies, can bring fuel consumption levels down to 1 litre ge/100 km.

The Figure 12.12 gives the energy intensities calculated using power train market shares and efficiency improvements for LDV in the Reference scenario and in the Energy [R]evolution scenario.

The energy intensities for car passenger transport are currently highest in OECD North America and lowest in OECD Europe. The Reference scenario shows a decrease in energy intensities in all regions, but the division between highest and lowest will remain the same, although there will be some convergence.

**TABLE 12.5 | TECHNICAL EFFICIENCY POTENTIAL FOR WORLD PASSENGER TRANSPORT<sup>17</sup>**

MJ/P-KM	STATUS QUO	E[R] 2050
LDV	1.5	0.3
AIR (DOMESTIC)	2.5	1.2
BUSES	0.5	0.3
MINI-BUSES	0.5	0.3
TWO WHEELS	0.5	0.3
THREE WHEELS	0.7	0.5
PASSENGER RAIL	0.4	0.2

We have assumed that the occupancy rate for cars remains nearly the same as in 2009, as shown in Figure 12.13.

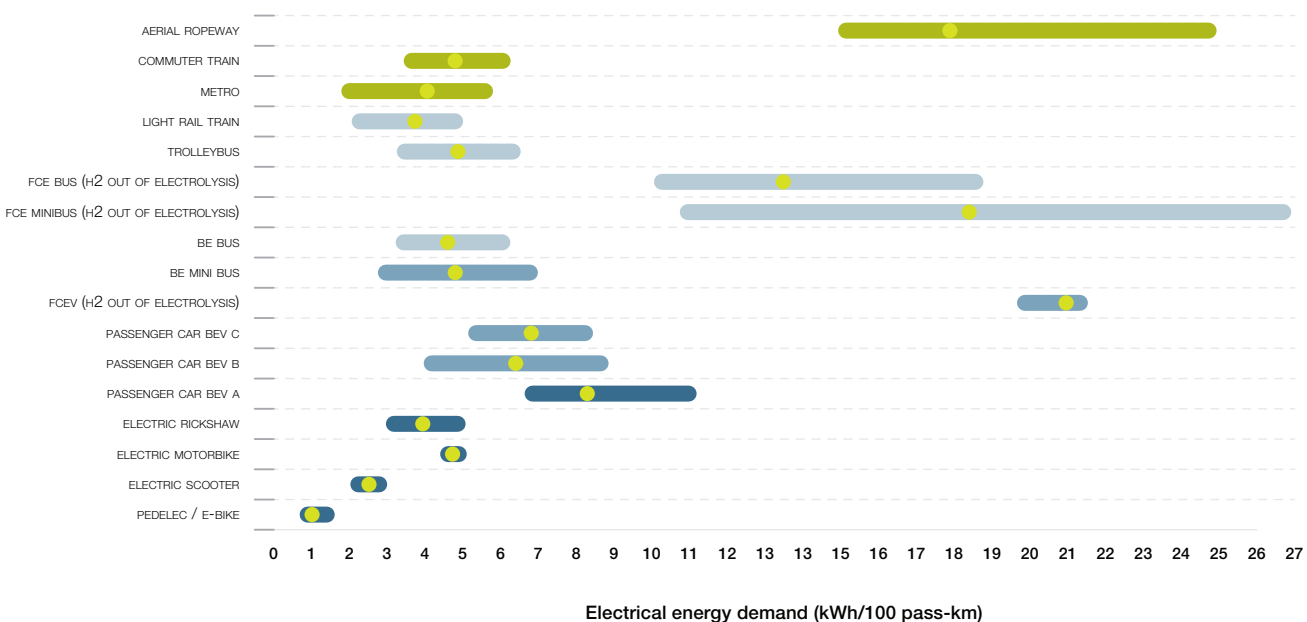
Table 12.5 summarises the energy efficiency improvement for passenger transport in the Energy [R]evolution 2050 scenario and Table 12.6 shows the energy efficiency improvement for freight transport in the Advanced Energy [R]evolution 2050 scenario.

Figure 12.14 provides an overview about electric transport vehicles for urban areas. The figures are results of a specific research commissioned from Greenpeace international for public and energy efficient individual transport technologies.

**TABLE 12.6 | TECHNICAL EFFICIENCY POTENTIAL FOR WORLD FREIGHT TRANSPORT<sup>17</sup>**

MJ/T-KM	STATUS QUO	E[R] 2050
MDV	4.8	2.7
HDV	1.6	0.8
FREIGHT RAIL	0.2	0.1
INLAND NAVIGATION	0.5	0.3

**FIGURE 12.14 | OVERVIEW ELECTRICITY DEMAND OF TRANSPORT TECHNOLOGIES PER 100 PASSENGER KILOMETERS**



source DLR 2015.

**TABLE 12.7 | SELECTED PARAMETERS FOR VEHICLE TECHNOLOGIES FOR CITY APPLICATIONS**

TRANSPORT MODE CHARACTERISTICS			INDIVIDUAL TRANSPORT SYSTEMS								FREIGHT	
			E-BIKES	SCOOTERS	MOTORBIKES	RICKSHAW	CAR				ELECTRIC N1 FREIGHT VEHICLE	
			ROAD	2-WHEELER	ROAD	3-WHEELS	SMALL	MEDIUM	LARGE	LARGE	BATTERY	FUEL CELL
			BATTERY	BATTERY	BATTERY	BATTERY	BATTERY	BATTERY	BATTERY	BATTERY	FUEL CELL	BATTERY
<b>TRANSPORT CAPACITY</b>												
PASSENGERS	AVERAGE	PASSENGERS PER VEHICLE	1	1	1	5+1	2	4	5	4	0.600	0.600
	MIN / MAX		(1-2)	(1-3)		(4-7)+1	(2-4)	(4-5)	(4-7)	(4-5)	(0.306-1.400)	(0.306-1.400)
SPEED	AVERAGE	KM/H	18	45	170	35	100	115	140	166	110	110
	MIN / MAX	KM/H	(14-22)	(25-60)	(150-240)	(20-50)	(45-130)	(60-150)	(120-180)	(160-170)	(45-130)	(45-130)
RANGE	AVERAGE	KM	50		190	80	130	150	180	480	150	425
	MIN / MAX	KM	30-60		(50-300)	(40-150)	(40-160)	(100-220)	(150-320)	(380-580)	(65-170)	(281-425)
TANK TO WHEEL ENERGY CONSUMPTION	AVERAGE	kWh <sub>int</sub> /100 VKM	1.03	2.0	4.5-5.0	8	15	16	17	34	18	44
VEHICLE DEMAND	MIN / MAX	kWh <sub>int</sub> /100 VKM		(1.0-2.5)		(6-10)	(12-20)	(10-22)	(13-21)	(32-35)	(12-26)	
<b>ENERGY DEMAND</b>												
ELECTRICITY CONSUMPTION PER PASSENGER	AVERAGE	kWh <sub>int</sub> /100 PASS-KM	1	2.5	4.8	4	8.3	6.4	6.8	20.9		
ASSUMED OCCUPATION RATES IN PERSONS	MIN / MAX	kWh <sub>int</sub> /100 PASS-KM	(0,8-1,5)	(2,1-2,95)	(4,5-5)	(3-5)	(6,7-11,1)	(4-8,8)	(5,2-8,4)	(19,7-21,5)		
<b>ECONOMICS</b>						18,000				58,000		
VEHICLE PRICE	AVERAGE	US\$ <sub>2014</sub>	700	650	(9,900-39,000)	850	25,000	36,000	45,000	(32,000-77,000)	35,000	86,200
	MIN / MAX	US\$ <sub>2014</sub>	(400-2,000)	(370-860)	97,000 – 2,000)	(410 – 2,000)	(9,300-65,000)	(8,000 c-70,000)	(32,000-77,000)		(29,600-60,000)	
LIFE TIME VEHICLE	AVERAGE	KM		50,000	121,000	10						
LIFE TIME OF BATTERY / FUEL CELL	MIN / MAX	A (YEARS)	10	10		15	16	16	16	16	12	12
	AVERAGE	A (YEARS)	3-5	2-6		15	>8	>8			8	
	MIN / MAX	A (YEARS)										
	AVERAGE	KM								130		130
	AVERAGE	CYCLES	300-1,000	(300-1,000)	1,200	650					(1,000-4,500)	

TRANSPORT MODE CHARACTERISTICS			PUBLIC TRANSPORT										
			MINI BUS	MINI BUS	BUS	BUS	TROLLEY-BUS	TRAMS	METROS	COMMUTER TRAINS	AERIAL ROPEWAY SYSTEMS		
			SMALL	SMALL	12 M	12 M	LARGE						
			ROAD	ROAD	ROAD	ROAD	ROAD	RAIL	RAIL	RAIL	RAIL	RAIL	
<b>TRANSPORT CAPACITY</b>													
PASSENGERS	AVERAGE	PASSENGERS PER VEHICLE	15	15	75	75	135	300	800	1,000			
	MIN / MAX		(10-30)	(10-30)	(60-80)	(60-80)	(120-150)	(140-500)	(200-1,500)	(300-1,500)			
SPEED	AVERAGE	PASSENGERS PER HOUR	300	300	1,500	1,500	2,700	6,000	16,000	20,000	4,000		
	MIN / MAX		200-600	200-600	1,200-1,600	1,200-1,600	2,400-3,000	2,800-10,000	(4,000-24,000)	(6,000-30,000)	(3,000-6,000)		
RANGE	AVERAGE	KM/H	70	70	90	90	80	70	80	100	27		
	MIN / MAX	KM/H	(60-80)	(60-80)	(80-100)	(80-100)	(60-100)	(60-80)	(60-90)	(80-140)	(21-31)		
TANK TO WHEEL ENERGY CONSUMPTION	AVERAGE	KM	130	250	250	350	NOT LIMITED	NOT LIMITED	NOT LIMITED	NOT LIMITED	NOT LIMITED		
	MIN / MAX	KM	(80-200)	(150-500)	(150-300)	(250-400)							
VEHICLE DEMAND	MIN / MAX	kWh <sub>int</sub> /100 VKM	30	75	135	340	263	450	1280	1,900	8		
VEHICLE DEMAND	MIN / MAX	kWh <sub>int</sub> /100 VKM	(17-44)	(43-110)	(98-188)	(245-470)	(175-350)	(240-750)	(560-1,840)	(1,400-2,500)	(6-10)		
<b>ENERGY DEMAND</b>													
ELECTRICITY CONSUMPTION PER PASSENGER	AVERAGE	kWh <sub>int</sub> /100 PASS-KM	4.75	18.5	4.5	13.5	4.9	3.8	4	4.8	20		
ASSUMED OCCUPATION RATES IN PERSONS	MIN / MAX	kWh <sub>int</sub> /100 PASS-KM	(2,75-7)	(10,8-26,9)	(3,25-6,25)	(10-18,8)	(3,3-6,5)	(2-5)	(1,8-5,8)	(3,5-6,3)	(15-25)		
<b>ECONOMICS</b>													
VEHICLE PRICE	AVERAGE	US\$ <sub>2014</sub>	80,000	250	400,000	1,000,000	900,000	4,000,000	9,000,000	1,200,000			
	MIN / MAX	US\$ <sub>2014</sub>	(30,000-200,000)	(150,000-800,000)	(200,000-1,000,000)	(600,000-1,500,000)	(600,000-1,300,000)	(3,500,000-4,200,000)	(6,000,000-15,000,000)	(8,000,000-15,000,000)			
LIFE TIME VEHICLE	AVERAGE	KM											
FUEL CELL	MIN / MAX	A (YEARS)	12	12	12	12	20	30	30	30	30		
	AVERAGE	A (YEARS)	(10-20)	(10-20)	(10-20)	(10-20)	(15-25)	(20-40)	(20-40)	(20-40)	(20-40)		
INFRASTRUCTURE COST	MIN / MAX	A (YEARS)	8	4	8	4							
	AVERAGE	A (YEARS)	(3-15)	(3-5)	(3-15)	(3-5)							
	AVERAGE	KM											
	AVERAGE	CYCLES											
INFRASTRUCTURE COST		MUSD/KM						25	120	70	12		
								(20-32)	(70-200)	(20-150)	(5-20)		

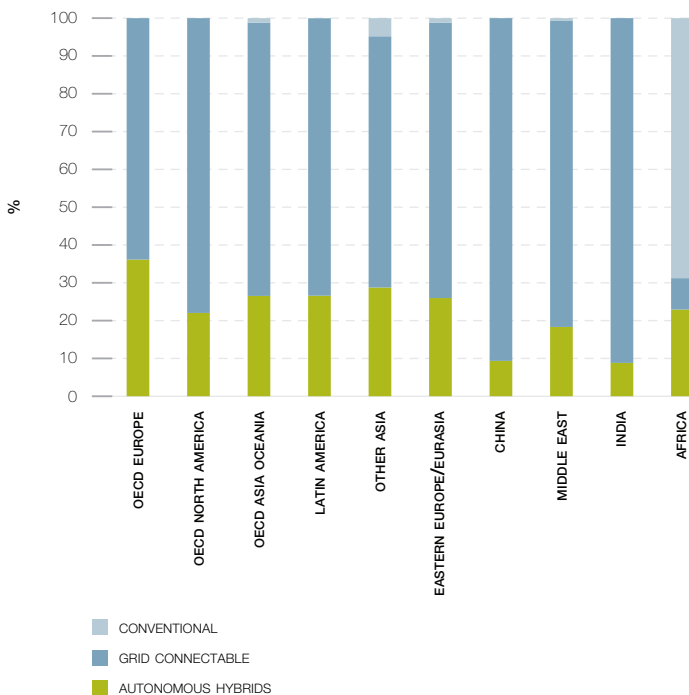
## 12.3 PROJECTION OF THE FUTURE CAR MARKET

### 12.3.1 PROJECTION OF THE FUTURE TECHNOLOGY MIX

Achieving the substantial CO<sub>2</sub>-reduction targets in the Energy [R]evolution scenario would require a radical shift in fuels for cars and other light duty vehicles. For viable, full electrification based on renewable energy sources, the model assumes that petrol and diesel fuelled autonomous hybrids and plug-in hybrids that we have today are phased out already by 2050 in the Advanced Energy [R]evolution scenario. Thus, two generations of hybrid technologies will pave the way for the complete transformation to light duty vehicles with full battery electric or hydrogen fuel cell powertrains. This is the only way that is efficient enough for the use of renewable energy to reach the CO<sub>2</sub>-targets in the car sector.

In the future, it may not be possible to power cars for all purposes by rechargeable batteries only. Therefore, hydrogen and synfuels are required as a renewable fuel especially for larger cars including light commercial vehicles. Biofuels and synfuels will be used in other applications where a substitution is even harder than for cars. Figure 12.15 shows the share of fuel cell vehicles (autonomous hybrids) and full battery electric vehicles (grid connectable) in 2050 in the new vehicle market according to the projections in (DLR 2012).

**FIGURE 12.15 | SALES SHARE OF CONVENTIONAL ICE, AUTONOMOUS HYBRID AND GRID-CONNECTABLE VEHICLES IN 2050<sup>17</sup>**

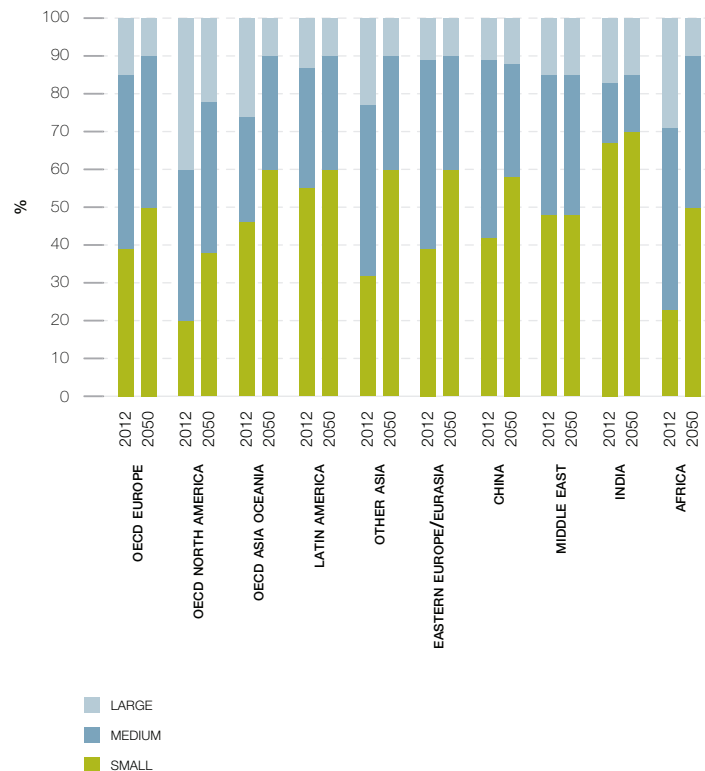


### 12.3.2 PROJECTION OF THE FUTURE VEHICLE SEGMENT SPLIT

The scenario is constructed to disaggregate the light-duty vehicle sales into three segments: small, medium and large vehicles. This model shows the effect of 'driving small urban cars' to see if they are suitable for megacities of the future. The size and CO<sub>2</sub> emissions of the vehicles are particularly interesting in the light of the enormous growth predicted in the LDV stock. For our purposes, we could divide up the numerous car types as follows:

- The very small car bracket includes city, super-mini, mini-compact cars as well as one and two seaters.
- The small sized bracket includes compact and subcompact cars, micro and subcompact vans and small SUVs.
- The medium sized bracket includes car derived vans and small station wagons, upper medium class, midsize cars and station wagons, executive class, compact passenger vans, car derived pickups, medium SUVs, 2WD and 4WD.
- The large car bracket includes all kinds of luxury class, luxury multi-purpose vehicles, medium and heavy vans, compact and full-size pickup trucks (2WD, 4WD), standard and luxury SUVs. In addition, we looked at light duty trucks in North America and light commercial vehicles in China separately.

**FIGURE 12.16 | ASSUMED VEHICLE SALES BY SEGMENT CURRENTLY AND 2050 UNDER THE ENERGY [R]EVOLUTION<sup>17</sup>**



In examining the segment split, we have focused most strongly on the two world regions which will be the largest emitters of CO<sub>2</sub> from cars in 2050: North America and China. In North America today, the small vehicle segment is almost non-existent. We found it necessary to introduce here small cars substantially, triggered by rising fuel prices and possibly vehicle taxes. For China, we have anticipated a similar share of the mature car market as for Europe and projected that the small segment will grow by 3% per year at the expenses of the larger segments in the light of rising mass mobility. The segment split is shown in Figure 12.16.

### 12.3.3 PROJECTION OF THE FUTURE SWITCH TO ALTERNATIVE FUELS

A switch to renewable fuels in the car fleet is one of the cornerstones of the low CO<sub>2</sub> car scenario, with the most prominent element the direct use of renewable electricity in cars. The different types of electric and hybrid cars, such as battery electric and plug-in hybrid, are summarised as 'plug-in electric'. Their introduction will start in industrialised countries between 2015 and 2020, following an s-curve pattern, and are projected to reach 35-40% of total LDV sales in the EU, North America and the OECD Asia Oceania by 2050. Due to the higher costs of the technology and renewable electricity availability, we have slightly delayed progress in other countries. More cautious targets are applied for Africa.

There are huge differences in forecasts for the growth of vehicle sales in developing countries. In general, the increase in sales and thus vehicle stock and ownership is linked to the forecast of GDP growth, which is a well-established correlation in the science community. However, this scenario analysis found that technology shift in LDVs alone – although linked to enormous efficiency gains and fuel switch - is not enough to fulfil the ambitious Energy [R]evolution CO<sub>2</sub> targets. A slowdown of vehicle sales growth and a limitation or even reduction in vehicle ownership per capita compared to the Reference scenario was thus required.

Global urbanisation, the on-going rise of megacities, where space for parking is scarce, and the trend starting today that ownership of cars might not be seen as desirable as in the past draws a different scenario of the future compared to the reference case. Going against the global pattern of a century, this development would have to be supported by massive policy intervention to promote modal shift and alternative forms of car usage. For megacities, Greenpeace commissioned an additional specific research, key results are presented in Table 12.7.

### 12.3.4 PROJECTION OF THE FUTURE KILOMETRES DRIVEN PER YEAR

Until a full shift from fossil to renewable fuels has taken place, driving on the road will create CO<sub>2</sub> emissions. Thus, driving less contributes to our target for emissions reduction. However, this shift does not have to mean reduced mobility equally because there are many excellent opportunities for shifts from individual passenger road transport towards less CO<sub>2</sub>-intensive public and non-motorised transport.

Data on average annual kilometres driven are uncertain in many world regions except for North America, Europe and recently China. The scenario starts from the state-of-the-art knowledge on how LDVs are driven in the different world regions and then projects a decline in car usage. This is a further major building block in the low carbon strategy of the Energy [R]evolution scenarios, which goes hand in hand with new mobility concepts like co-modality and car-sharing concepts. In 2050, policies supporting the use of public transport and environmental friendly modes are anticipated to be in place in all world regions. Our scenario of annual kilometres driven (AKD) by LDVs is shown in Figure 12.17. In total, AKD fall almost by one quarter until 2050 compared to 2012.

FIGURE 12.17 | DEVELOPMENT OF THE AVERAGE ANNUAL LDV KILOMETRES DRIVEN PER WORLD REGION UNDER THE ENERGY [R]EVOLUTION<sup>17</sup>

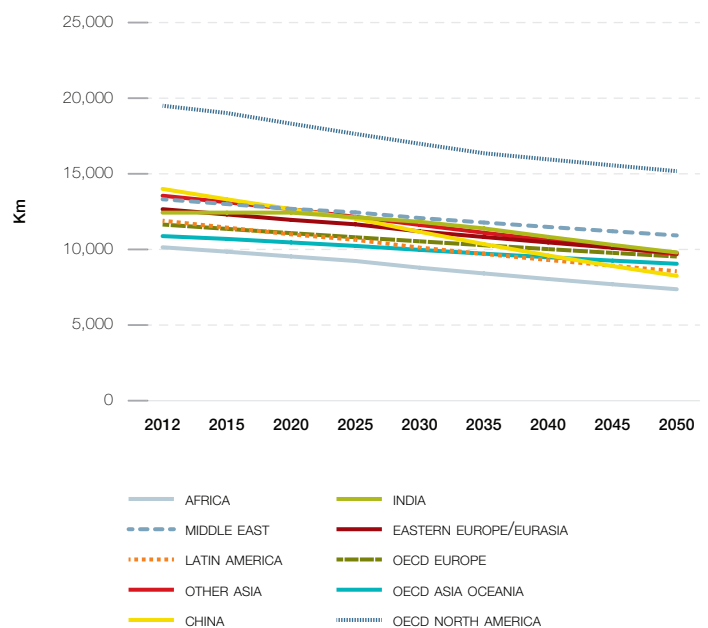
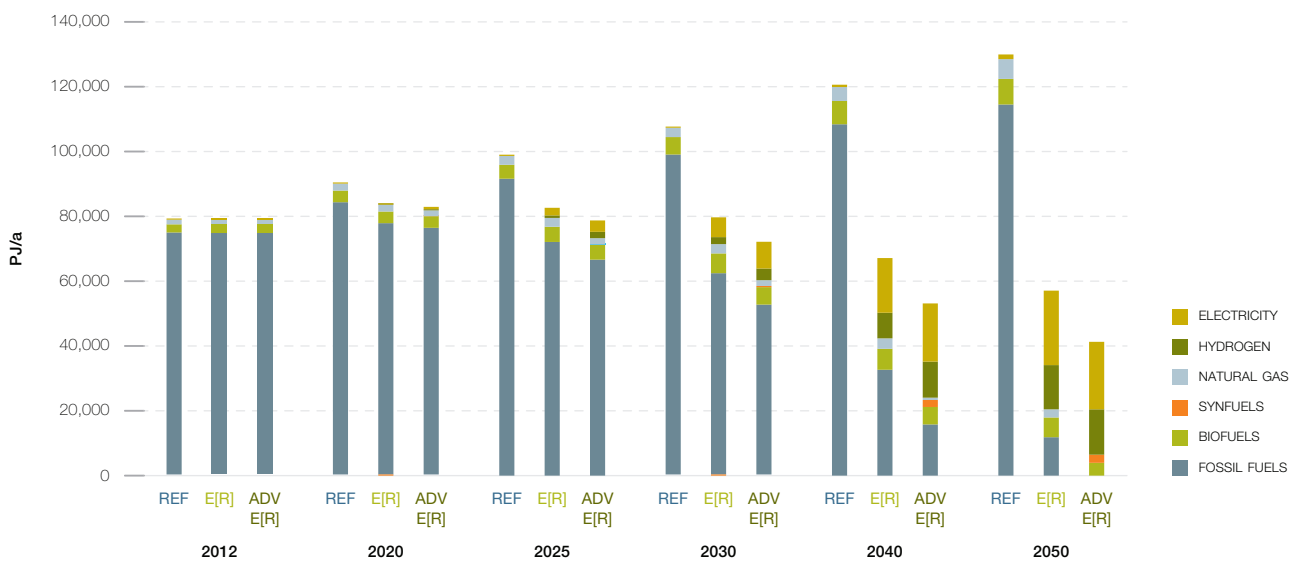




Figure 12.18 shows the final energy consumption by technologies under 3 scenarios for road transport. The implementation of new alternatives drives – mainly in combination with electric machines – start to have an impact after 2025 and can take over a significant share after 2035. Synfuels, however are believed to be equally important especially for large vehicles including trucks and busses.

**FIGURE 12.18 | DEVELOPMENT OF FINAL ENERGY USE FOR ROAD TRANSPORT BY TECHNOLOGIES IN THE REFERENCE AND BOTH ENERGY [R]EVOLUTION SCENARIOS**



## 12.4 CONCLUSION

In a business as usual world we project a high rise of transport energy demand until 2050 in all world regions in the Reference scenario, which is fuelled especially by fast developing countries like China and India.

The aim of this Chapter was therefore to show ways to reduce energy demand in general and the dependency on climate damaging fossil fuels in the transport sector. The findings of our scenario calculations show that a combination of behavioural changes and tremendous technical efforts is needed in order to reach the ambitious energy reduction goals of the Energy [R]evolution scenario:

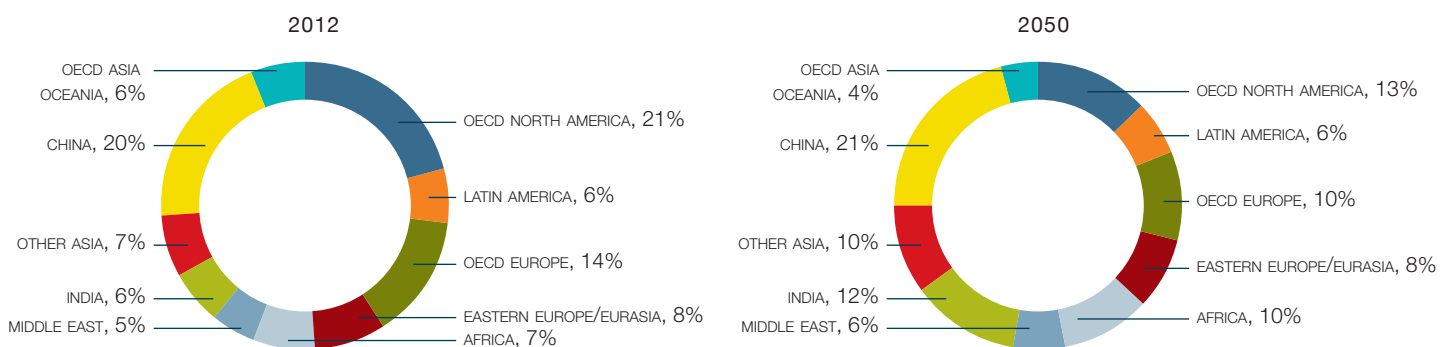
- a decrease of passenger and freight kilometres on a per capita base
- a massive shift to electrically and hydrogen powered vehicles whose energy sources may be produced by renewables

- a gradual decrease of all modes' energy intensities by technological progress
- a modal shift from aviation to high speed rail and from road freight to rail freight.

These measures must of course be accompanied by major efforts in the installation and extension of the necessary infrastructures as for example in railway networks hydrogen and battery charging infrastructure for electric vehicles and an electrification of highways.

Figure 12.19 shows the development of the regional shares of transport demands by region under both Energy [R]evolution scenarios between 2012 and 2050. The main difference is a more equal distribution of the transport energy demand across all regions in regard to transport energy per person.

FIGURE 12.19 | WORLD FINAL ENERGY USE BY REGION 2012 – 2050 – ENERGY [R]EVOLUTION SCENARIOS<sup>17</sup>



# GLOSSARY, REFERENCES & APPENDIX

REFERENCES

GLOSSARY OF COMMONLY USED  
TERMS AND ABBREVIATIONS

ANNEXES



“  
may the  
(data) force  
be with you”

**IMAGE** LOCATED NEAR THE EQUATOR IN CENTRAL AFRICA, THE NYAMURAGIRA AND NYIRAGONGO VOLCANOES ARE OFTEN OBSCURED FROM SATELLITE VIEW BY CLOUDS. BUT ON FEBRUARY 9, 2015, CLEAR SKIES AFFORDED AN UNOBSTRUCTED VIEW FROM SPACE OF TWO PLUMES VENTING FROM THE VOLCANIC DUO IN THE DEMOCRATIC REPUBLIC OF THE CONGO. OCCASIONALLY, NYIRAGONGO SPEWS MORE THAN JUST STEAM AND VOLCANIC GASES. ERUPTIONS OF FLUID LAVA FROM THE VOLCANO IN 1977 AND 2002 HAD DEADLY CONSEQUENCES FOR THE CITY OF GOMA, WHICH LIES ABOUT 15 KILOMETERS (9 MILES) SOUTH OF THE VOLCANO.

© NASA EARTH OBSERVATORY IMAGES BY JESSE ALLEN

### 13.1 REFERENCES

#### INTRODUCTION

- 1 LINK TO REPORT: [HTTP://WWW.MC-GROUP.COM/THE-RENEWABLE-ENERGY-REVOLUTION/](http://www.mc-group.com/the-renewable-energy-revolution/)
- 2 SEE [HTTP://WWW.CARBONTRACKER.ORG/NEWS/BANK-OF-ENGLANDS-MOMENTOUS-MOVE-ON-CLIMATE-CHANGE/](http://www.carbontracker.org/news/bank-of-englands-momentous-move-on-climate-change/) AND [HTTP://WWW.BLOOMBERG.COM/NEWS/ARTICLES/2014-12-18/BANKERS-SEE-1-TRILLION-OF-INVESTMENTS-STRANDED-IN-THE-OIL-FIELDS](http://www.bloomberg.com/news/articles/2014-12-18/bankers-see-1-trillion-of-investments-stranded-in-the-oil-fields)

#### EXECUTIVE SUMMARY

- 1 IPCC – SPECIAL REPORT RENEWABLES, CHAPTER 1, MAY 2011.
- 2 (IEA – TCEP 2015) TRACKING CLEAN – ENERGY PROGRESS 2015; ENERGY TECHNOLOGY PERSPECTIVES 2015 EXCERPT; IEA INPUT TO THE CLEAN ENERGY MINISTERIAL; INTERNATIONAL ENERGY AGENCY; 9 RUE DE LA FÉDÉRATION; 75739 PARIS CEDEX 15, FRANCE; WWW.IEA.ORG.
- 3 (REN21-2015); RENEWABLES 2015 GLOBAL STATUS REPORT, PARIS: REN21 SECRETARIAT; WWW.REN21.NET; ISBN 978-3-9815934-6-4

#### CHAPTER 1

- 1 (IPCC-AR5-SPM) INTERNATIONAL PANEL ON CLIMATE CHANGE – 5TH ASSESSMENT REPORT; CLIMATE CHANGE 2014, SUMMARY FOTR POLICY MAKERS; [HTTP://IPCC.CH/PDF/ASSESSMENT-REPORT/AR5/SYR/AR5\\_SYR\\_FINAL\\_SPM.PD](http://ipcc.ch/pdf/assessment-report/ar5/syr/ar5_syr_final_spm.pdf)
- 2 (WNISR 2015) WORLD NUCLEAR INDUSTRY STATUS REPORT 2015, MYCLE SCHNEIDER, ANTONY FROGGATT ET. AL.; PARIS / LONDON 2015.
- 3 (REN 21-2015); GLOBAL STATUS REPORT RENEWABLES 2015, REN 21; PARIS.
- 4 ATOMAUSTRIEGESSETZ – 30 JUNE 2011.
- 5 (IEA-WEO-SR-2015) INTERNATIONAL ENERGY AGENCY; WORLD ENERGY OUTLOOK 2015 – SPECIAL REPORT ENERGY AND CLIMATE; JUNE 2015; PARIS/FRANCE.
- 6 'WASTE MANAGEMENT IN THE NUCLEAR FUEL CYCLE', WORLD NUCLEAR ASSOCIATION, INFORMATION AND ISSUE BRIEF, FEBRUARY 2006 (WWW.WORLD-NUCLEAR.ORG/INFO/INF04.HTM).
- 7 MOHAMED ELBARADEI, 'TOWARDS A SAFER WORLD', ECONOMIST, 18 OCTOBER 2003.
- 8 IPCC WORKING GROUP II, 'IMPACTS, ADAPTATIONS AND MITIGATION OF CLIMATE CHANGE: SCIENTIFIC-TECHNICAL ANALYSES', 1995.

#### CHAPTER 2

- 1 REN21 – RENEWABLES 2015 – GLOBAL STATUS REPORT; JUNE 2015, PARIS / FRANCE.

#### CHAPTER 3

- 1 IPCC – SPECIAL REPORT RENEWABLES, CHAPTER 1, MAY 2011.
- 2 (IEA – TCEP 2015) TRACKING CLEAN – ENERGY PROGRESS 2015; ENERGY TECHNOLOGY PERSPECTIVES 2015 EXCERPT; IEA INPUT TO THE CLEAN ENERGY MINISTERIAL; INTERNATIONAL ENERGY AGENCY; 9 RUE DE LA FÉDÉRATION; 75739 PARIS CEDEX 15, FRANCE; WWW.IEA.ORG.
- 3 (REN21-2015); RENEWABLES 2015 GLOBAL STATUS REPORT, PARIS: REN21 SECRETARIAT; WWW.REN21.NET; ISBN 978-3-9815934-6-4
- 4 (IRENA-GLOBAL ATLAS 2015) GLOBAL ATLAS FOR RENEWABLE ENERGY; INTERNATIONAL RENEWABLE ENERGY AGENCY (IRENA); ABU DHABI / UAE; BONN/GERMANY; [HTTP://IRENA.MASDAR.AC.AE/#/](http://irena.masdar.ac.ae/#/); JULY 2015.
- 5 (DBFZ 2008); GLOBAL BIOMASS POTENTIALS – INVESTIGATION AND ASSESSMENT OF DATA – REMOTE SENSING IN BIOMASS POTENTIAL RESEARCH – COUNTRY SPECIFIC ENERGY CROP POTENTIAL; SEIDENBERGER ET. AL.; DEUTSCHES BIOMASSEFORSCHUNGSZENTRUM; LEIPZIG/GERMANY, JUNE 2008.
- 6 (JUN 2014) ADD EXACT REFERENCE FOR POPULATION PROJECTION.
- 7 (GWEC 2015) GLOBAL WIND REPORT: ANNUAL MARKET UPDATE; MARKET PROJECTION 2015 – 2019; BRUSSELS / BELGIUM; MAY 2015.
- 8 (SPE 2015) GLOBAL MARKET OUTLOOK FOR SOLAR POWER 2015 – 2019; SOLAR POWER EUROPE; BRUSSELS / BELGIUM; MAY 2015.
- 9 (BROWN ET. AL. 2014) OPTIMISING THE EUROPEAN TRANSMISSION SYSTEM FOR 77% RENEWABLES BY 2030; TOM BROWN, PETER-PHILIPP SCHIEPHORN, ECKEHARD TROSTER, THOMAS ACKERMANN; ENERGYNAUTICS GMBH, ROBERT-BOSCH-STRASSE 7, 64293 DARMSTADT, GERMANY.
- 10 (TESKE 2015); BRIDGING THE GAP BETWEEN ENERGY- AND GRID MODELS - DEVELOPING AN INTEGRATED INFRASTRUCTURAL PLANNING MODEL FOR 100% RENEWABLE ENERGY SYSTEMS IN ORDER TO OPTIMIZE THE INTERACTION OF FLEXIBLE POWER GENERATION, SMART GRIDS AND STORAGE TECHNOLOGIES; DISSERTATION; EUROPA UNIVERSITÄT FLENSBURG/GERMANY, SVEN TESKE DR. RER.POL.; DIPL.-ING.; JUNE 2015.
- 11 (REN21-2015); RENEWABLES 2015 GLOBAL STATUS REPORT, PARIS: CH. 4; REN21 SECRETARIAT; WWW.REN21.NET; ISBN 978-3-9815934-6-4.
- 12 (IRENA 2015 A) RENEWABLE ENERGY TARGET SETTING, INTERNATIONAL RENEWABLE ENERGY AGENCY; JUNE 2015, [HTTP://WWW.IRENA.ORG/DOCUMENTDOWNLOADS/PUBLICATIONS/IRENA\\_RE\\_TARGET\\_SETTING\\_2015.PDF](http://www.irena.org/documentdownloads/publications/irena_re_target_setting_2015.pdf)
- 13 'IEA WORLD ENERGY OUTLOOK 2014, PARIS NOVEMBER 2014.
- 14 (IEA 2015 B) ENERGY AND CLIMATE CHANGE – WORLD ENERGY OUTLOOK SPECIAL REPORT; INTERNATIONAL RENEWABLE ENERGY AGENCY; MAY 2015.
- 15 (WFC 2014); REGENERATIVE CITIES – COMMISSION ON CITIES AND CLIMATE CHANGE; HAFEN CITY UNIVERSITY, WORLD FUTURE COUNCIL; SEPTEMBER 2014.
- 16 SEE CHAPTER 12.
- 17 (GP-EN 2014) POWE[R] 2030 - A EUROPEAN GRID FOR 3/4 RENEWABLE ELECTRICITY BY 2030; GREENPEACE INTERNATIONAL / ENERGYNAUTICS; MARCH 2014.
- 18 SEE ALSO ECOGRID PHASE 1 SUMMARY REPORT, AVAILABLE AT: [HTTP://WWW.ENERGINET.DK/NR/RDONLYRES/8B144A06-CBA3-41DA-9402-B56C2C288FB0/0/ECOGRIDDK\\_PHASE1\\_SUMMARYREPORT.PDF](http://www.energinet.dk/nr/rdonlyres/8b144a06-cba3-41da-9402-b56c2c288fb0/0/ECOGRIDDK_PHASE1_SUMMARYREPORT.PDF)
- 19 (GP-EN 2009) EUROPEAN RENEWABLE ENERGY COUNCIL/GREENPEACE REPORT, 'R[ENEWABLES 24/7: INFRASTRUCTURE NEEDED TO SAVE THE CLIMATE]', NOVEMBER 2009.
- 20 (BEYER 2015) PV LCOE IN EUROPE 2014-30; FINAL REPORT, JULY 2015; UNIVERSITY LAPPEENRANTA / FINLAND, DR. CHRISTIAN BREYER; PV TECHNOLOGY PLATFORM;WWW.EUPVPLATFORM.ORG
- 21 (PV-M 3-2015); PV MAGAZINE, RWE PROFITS SLUMP AMID CRISIS IN CONVENTIONAL ENERGY; 10TH MARCH 2015; IAN CLOVER; [HTTP://WWW.PV-MAGAZINE.COM/NEWS/DETAILS/BEITRAG/RWE-PROFITS-SLUMP-AMID-CRISIS-IN-CONVENTIONAL-ENERGY\\_10001853](http://www.pv-magazine.com/news/details/beitrag/rwe-profits-slump-amid-crisis-in-conventional-energy_10001853)

#### CHAPTER 4

- 1 (SWISS RE 2011), AN INTRODUCTION TO RENEWABLE ENERGY INFRASTRUCTURE INVESTING; CONTACT: ROBERT NEF; CO-HEAD INVESTOR SOLUTIONS; ROBERT\_NEF@SWISSRE.COM; +41 43 285 2121/NEWABLE ENERGY INFRASTRUCTURE INVESTING - SWISS RE PRIVATE EQUITY PARTNERS; SEPTEMBER 2011.
- 2 SOURCES INCLUDE: INTERGOVERNMENTAL PANEL ON CLIMATE CHANGE (IPCC) (2011) SPECIAL REPORT ON RENEWABLE ENERGY SOURCES AND CLIMATE CHANGE MITIGATION (SRREN), 15TH JUNE 2011. UNITED NATIONS ENVIRONMENT PROGRAMME (UNEP), BLOOMBERG NEW ENERGY FINANCE (BNEF) (2015). GLOBAL TRENDS IN RENEWABLE ENERGY INVESTMENT 2015, MARCH 2015.

- RENEWABLE ENERGY POLICY NETWORK FOR THE 21ST CENTURY (REN21) (2015). RENEWABLES 2015, GLOBAL STATUS REPORT, JUNE 2015.
- ECOFYS, FRAUNHOFER ISI, TU VIENNA EEG, ERNST & YOUNG (2011). FINANCING RENEWABLE ENERGY IN THE EUROPEAN ENERGY MARKET BY ORDER OF EUROPEAN COMMISSION, DG ENERGY, 2ND OF JANUARY, 2011.
- INTERGOVERNMENTAL PANEL ON CLIMATE CHANGE (IPCC) (2011) SPECIAL REPORT ON RENEWABLE ENERGY SOURCES AND CLIMATE CHANGE MITIGATION (SRREN), 15TH JUNE 2011. CHP. 11, P.24.
- CLIMATE POLICY INITIATIVE (2011); THE IMPACTS OF POLICY ON THE FINANCING OF RENEWABLE PROJECTS: A CASE STUDY ANALYSIS, 3 OCTOBER 2011.
- (REN21-2014-B); THE FIRST DECADE 2004 – 2014; 10 YEARS OF RENEWABLE ENERGY PROGRESS; REN21; C/O UNEP; 15, RUE DE MILAN, F-75441 PARIS CEDEX 09; FRANCE; OCTOBER 2014; WWW.REN21.NET.
- (REN21 – 2015); RENEWABLES 2015 -GLOBAL STATUS REPORT; ANNUAL REPORTING ON RENEWABLES: TEN YEARS OF EXCELLENCE; REN21; C/O UNEP; 15, RUE DE MILAN, F-75441 PARIS CEDEX 09, FRANCE; JUNE 2015; WWW.REN21.NET
- (UNEP-BLOOMBERG NEF 2015); GLOBAL TRENDS IN RENEWABLE ENERGY INVESTMENT; 2015; FRANKFURT SCHOOL-UNEP CENTRE/BNEF. 2015. GLOBAL TRENDS IN RENEWABLE ENERGY INVESTMENT 2015, [HTTP://WWW.FS-UNEP-CENTRE.ORG](http://www.fs-unesp-centre.org) (FRANKFURT AM MAIN).

#### CHAPTER 5

- 1 INTERNATIONAL ENERGY AGENCY, 'WORLD ENERGY OUTLOOK 2014', 2014.
- 2 'ENERGY [R]EVOLUTION: A SUSTAINABLE WORLD ENERGY OUTLOOK', GREENPEACE INTERNATIONAL, 2007, 2008, 2010 AND 2012.
- 3 ENERGY [R]EVOLUTION: A SUSTAINABLE WORLD ENERGY OUTLOOK', GREENPEACE INTERNATIONAL, 2012.
- 4 GRAUS, KERMEI 2012: PROJECT REPORT - ENERGY DEMAND PROJECTIONS FOR ENERGY [R]EVOLUTION 2012. UTRECHT UNIVERSITY, MARCH 2012.
- 5 GLOBAL BIOMASS POTENTIALS - RESOURCES, DRIVERS AND SCENARIO RESULTS, THRÄN, D., SEIDENBERGER, T. ET AL., DBFZ 2010.
- 6 E.G. REN21 2015: RENEWABLES 2015 - GLOBAL STATUS REPORT; EWEA 2015: THE EUROPEAN OFFSHORE WIND INDUSTRY - KEY TRENDS AND STATISTICS 2014, AND OTHER REGIONAL STATISTICS AND DATA SOURCES.
- 7 E.G. PIETZCKER, STETTER ET AL. 2014: USING THE SUN TO DECARBONIZE THE POWER SECTOR: THE ECONOMIC POTENTIAL OF PHOTOVOLTAICS AND CONCENTRATING SOLAR POWER, APPLIED ENERGY, VOLUME 135, 15 DECEMBER 2014, PAGES 704-720; DENG ET AL. 2015: QUANTIFYING A REALISTIC, WORLDWIDE WIND AND SOLAR ELECTRICITY SUPPLY, GLOBAL ENVIRONMENTAL CHANGE 31 (2015) 239-252; DLR 2015: REMIX ENDAT MODELLING RESULTS PROVIDED BY THE GERMAN AEROSPACE CENTER, INSTITUTE OF ENGINEERING THERMODYNAMICS.
- 8 E.G. EPIA 2014: GLOBAL MARKET OUTLOOK FOR SOLAR POWER / 2015-2019.; GWEC 2014: GLOBAL WIND REPORT 2014; WEC 2015: WORLD ENERGY RESOURCES - CHARTING THE UPSURGE IN HYDROPOWER DEVELOPMENT 2015, AND AVAILABLE REGIONAL MARKET DEVELOPMENT PROJECTIONS.
- 9 DLR 2012: PROJECT REPORT - TRANSPORT SCENARIO BUILDING IN THE E[R] 2012. PAGENKOPF, J., SCHMID, S., FRIESKE, B., GERMAN AEROSPACE CENTER (DLR), INSTITUTE OF VEHICLE CONCEPTS; STUTTGART, GERMANY.
- 10 DLR 2015: PROJECT REPORT - ALTERNATIVE TRANSPORT TECHNOLOGIES FOR MEGACITIES; GERMAN AEROSPACE CENTER (DLR), INSTITUTE OF VEHICLE CONCEPTS; STUTTGART, GERMANY.
- 11 'ENERGY BALANCES OF NON-OECD COUNTRIES' AND 'ENERGY BALANCES OF OECD COUNTRIES', IEA, 2014.
- 12 FOR STATISTICAL REASONS, ISRAEL IS INCLUDED IN OECD EUROPE.
- 13 WEO 2014 DEFINES THE REGION „OECD AMERICAS“ AS USA, CANADA, MEXICO, AND CHILE. IN CONTRAST TO THAT THE ENERGY [R]EVOLUTION SCENARIOS CALCULATE CHILE WITH LATIN AMERICA TO MAINTAIN REGIONAL INTEGRITY.
- 14 CYPRUS, GIBRALTAR AND MALTA ARE ALLOCATED TO EASTERN EUROPE/EURASIA FOR STATISTICAL REASONS.
- 15 LATIN AMERICA INCLUDES CHILE, IN CONTRAST TO WEO 2014.
- 16 WORLD ENERGY OUTLOOK 2014 – ELECTRICITY ACCESS DATABASE, [HTTP://WWW.WORLDENERGYOUTLOOK.ORG/RESOURCES/ENERGYDEVELOPMENT/ENERGYACCESSDATABASE/](http://www.worldenergyoutlook.org/resources/energydevelopment/energyaccessdatabase/)
- 17 WORLD ENERGY OUTLOOK 2014 – TRADITIONAL USE OF SOLID BIOMASS FOR COOKING, [HTTP://WWW.WORLDENERGYOUTLOOK.ORG/RESOURCES/ENERGYDEVELOPMENT/ENERGYACCESSDATABASE/](http://www.worldenergyoutlook.org/resources/energydevelopment/energyaccessdatabase/)
- 18 WORLD POPULATION PROSPECTS: THE 2012 REVISION (MEDIUM VARIANT); UNITED NATIONS, POPULATION DIVISION, DEPARTMENT OF ECONOMIC AND SOCIAL AFFAIRS (UNDP), 2013
- 19 NORDHAUS, W. 'ALTERNATIVE MEASURES OF OUTPUT IN GLOBAL ECONOMIC-ENVIRONMENTAL MODELS: PURCHASING POWER PARITY OR MARKET EXCHANGE RATES?', REPORT PREPARED FOR IPCC EXPERT MEETING ON EMISSION SCENARIOS, US-EPA WASHINGTON DC, JANUARY 12-14, 2005.
- 20 IEA 2014: POWER GENERATION IN THE NEW POLICIES AND 450 SCENARIOS - ASSUMED INVESTMENT COSTS, OPERATION AND MAINTENANCE COSTS AND EFFICIENCIES IN THE IEA WORLD ENERGY INVESTMENT OUTLOOK 2014, DATA FILE DOWNLOAD: [HTTP://WWW.WORLDENERGYOUTLOOK.ORG/INVESTMENT/](http://www.worldenergyoutlook.org/investment/)
- 21 NEU, L. 'COST DEVELOPMENT OF FUTURE TECHNOLOGIES FOR POWER GENERATION - A STUDY BASED ON EXPERIENCE CURVES AND COMPLEMENTARY BOTTOM-UP ASSESSMENTS', ENERGY POLICY 36 (2008), 2200-2211.
- 22 WWW.NEEDS-PROJECT.ORG
- 23 EPIA 2014: GLOBAL MARKET OUTLOOK FOR SOLAR POWER / 2015 – 2019.
- 24 GWEC 2014: GLOBAL WIND REPORT 2014.
- 25 G.J. DALTON, T. LEWIS (2011): PERFORMANCE AND ECONOMIC FEASIBILITY ANALYSIS OF 5 WAVE ENERGY DEVICES OFF THE WEST COAST OF IRELAND; EWTEC 2011.
- 26 OLSON, O. ET AL. (2010); WP3-WOOD FUEL PRICE STATISTICS IN EUROPE - D.31. SOLUTIONS FOR BIOMASS FUEL MARKET BARRIERS AND RAW MATERIAL AVAILABILITY. EUBIONET3. UPPSALA, SWEDEN, SWEDISH UNIVERSITY OF AGRICULTURAL SCIENCES.
- 27 OWN ASSUMPTIONS, BASED ON DATA FROM THE HELMHOLTZ ALLIANCE PROJECT "SYNTHETIC LIQUID HYDROCARBONS" (SYNKWS), DLR, 2015.
- 28 (MCG 2015); RENEWABLE ENERGY REVOLUTION" – PUBLISHED MARCH 16, 2015 (MCG 2015) [HTTP://WWW.MC-GROUP.COM/WP-CONTENT/UPLOADS/2015/03/MCG-RENEWABLE-ENERGY-REVOLUTION-INFOGRAPHIC.PDF](http://www.mc-group.com/wp-content/uploads/2015/03/mcg-renewable-energy-revolution-infographic.pdf)

#### CHAPTER 7

- 1 RUTOVITZ, J., DOMINISH, E. AND DOWNES, J. 2015. CALCULATING GLOBAL ENERGY SECTOR JOBS: 2015 METHODOLOGY UPDATE. PREPARED FOR GREENPEACE INTERNATIONAL BY THE INSTITUTE FOR SUSTAINABLE FUTURES, UNIVERSITY OF TECHNOLOGY SYDNEY.
- 2 RUTOVITZ, J., DOMINISH, E. AND DOWNES, J. 2015. CALCULATING GLOBAL ENERGY SECTOR JOBS: 2015 METHODOLOGY UPDATE. PREPARED FOR GREENPEACE INTERNATIONAL BY THE INSTITUTE FOR SUSTAINABLE FUTURES, UNIVERSITY OF TECHNOLOGY SYDNEY.
- 3 DATA IS IN TONNES COAL EQUIVALENT, TO STANDARDISE BETWEEN REGIONS.
- 4 BP STATISTICAL REVIEW OF WORLD ENERGY 2015.

## CHAPTER 8

- 1 (REN21 – 2015); RENEWABLES 2015 - GLOBAL STATUS REPORT; ANNUAL REPORTING ON RENEWABLES: TEN YEARS OF EXCELLENCE; REN21; C/O UNEP; 15, RUE DE MILAN, F-75441 PARIS CEDEX 09, FRANCE; JUNE 2015; WWW.REN21.NET.
- 2 (OECD); ORGANISATION FOR ECONOMIC CO-OPERATION AND DEVELOPMENT.
- 3 (NBSC 2015); PRESS RELEASE FROM 15TH APRIL 2015; HTTP://WWW.STATS.GOV.CN/ENGLISH/PRESSRELEASE/201504/T20150415\_712435.HTML
- 4 (USA – ENERGY.GOV 2015); OFFICIAL INFORMATION FROM THE WEBSITE OF THE US GOVERNMENT: HTTP://ENERGY.GOV/SAVINGS/RENEWABLE-ELECTRICITY-PRODUCTION-TAX-CREDIT-PTC
- 5 WHILE THE OFFICIAL STATISTIC OF THE GLOBAL AND CHINESE WIND INDUSTRY ASSOCIATIONS (GWEC/CREIA) ADDS UP TO 18,900 MW FOR 2010, THE NATIONAL ENERGY BUREAU SPEAKS ABOUT 13,999 MW. THE DIFFERENCES BETWEEN SOURCES ARE DUE TO THE TIME OF GRID CONNECTION, AS SOME TURBINES WERE INSTALLED IN THE LAST MONTHS OF 2010 BUT ONLY CONNECTED TO THE GRID IN 2011. THESE EFFECTS ALSO MIGHT ARISE IN THE FOLLOWING YEAR TILL 2014.
- 6 (TESKE 2015) MARKET ANALYSIS BASED ON STATISTICS OF PLATTS, REN21, GWEC, SOLARPOWEREUROPE.

## CHAPTER 9

- 1 (IEA 2014) WORLD ENERGY OUTLOOK 2014; INTERNATIONAL ENERGY AGENCY; 9 RUE DE LA FÉDÉRATION; 75739 PARIS CEDEX 15, FRANCE; WWW.IEA.ORG; NOVEMBER 2014, ISBN: 978 92 64 20804 9
- 2 (GEA 2012); GLOBAL ENERGY ASSESSMENT - TOWARD A SUSTAINABLE FUTURE, CAMBRIDGE UNIVERSITY PRESS, CAMBRIDGE, UK AND NEW YORK, NY, USA AND THE INTERNATIONAL INSTITUTE FOR APPLIED SYSTEMS ANALYSIS, LAXENBURG, AUSTRIA; WWW.GLOBALENERGYASSESSMENT.ORG
- 3 (BP 2011) STATISTICAL REVIEW OF THE WORLD - 2011.
- 4 (BP 2015 – STATISTICAL REVIEW OF THE WORLD – 2015; WWW.BP.COM.
- 5 *THE INDEPENDENT*, 10 DECEMBER 2007.
- 6 (CSS 2014) CENTER FOR SUSTAINABLE SYSTEMS; UNIVERSITY OF MICHIGAN. 2014. "UNCONVENTIONAL FOSSIL FUELS FACTSHEET." PUB. NO. CSS13-19. OCTOBER 2014.
- 7 (INGAA 2008) INTERSTATE NATURAL GAS ASSOCIATION OF AMERICA (INGAA), "AVAILABILITY, ECONOMICS AND PRODUCTION POTENTIAL OF NORTH AMERICAN UNCONVENTIONAL NATURAL GAS SUPPLIES", NOVEMBER 2008.
- 8 (OECD NEA-2014) URANIUM 2014: RESOURCES, PRODUCTION AND DEMAND; OECD NUCLEAR ENERGY AGENCY; 12, BOULEVARD DES ÎLES; 92130 ISSY-LES-MOULINEAUX, FRANCE; WWW.OECD-NEA.ORG.
- 9 (OECD NEA 2003) "URANIUM 2003: RESOURCES, PRODUCTION AND DEMAND".
- 10 (RES 2007) "PLUGGING THE GAP - A SURVEY OF WORLD FUEL RESOURCES AND THEIR IMPACT ON THE DEVELOPMENT OF WIND ENERGY", RENEWABLE ENERGY SYSTEMS LTD (RES); BEAUFORT COURT EGG FARM LANE; KINGS LANGLEY HERTS WD4 8LR; UNITED KINGDOM; WEB: WWW.RES-GROUP.COM.
- 11 WBGU (GERMAN ADVISORY COUNCIL ON GLOBAL CHANGE).
- 12 (SRREN 2011) IPCC, 2011: IPCC SPECIAL REPORT ON RENEWABLE ENERGY SOURCES AND CLIMATE CHANGE MITIGATION. PREPARED BY WORKING GROUP III OF THE INTERGOVERNMENTAL PANEL ON CLIMATE CHANGE [O. EDENHOFER, R. PICHES-MADRUGA, Y. SOKONA, K. SEYBOTH, P. MATSCHOS, S. KADNER, T. ZWICKEL, P. EICKEMEIER, G. HANSEN, S. SCHLÖMER, C. VON STECHOW (EDS)]. CAMBRIDGE UNIVERSITY PRESS, CAMBRIDGE, UNITED KINGDOM AND NEW YORK, NY, USA. 1075 PP.
- 13 GREENPEACE DOES NOT NECESSARILY VALUE FEED ABOVE ENERGY. THE LIVESTOCK SECTOR IS LARGELY UNSUSTAINABLE AND SHOULD BE STRONGLY DECREASED IN MOST PARTS OF THE WORLD. HOWEVER, THE COMPETITION EFFECT OF A POLICY DRIVEN BIOENERGY MARKET WITH THE FOOD AND FEED MARKET LEAD TO UNCONTROLLABLE NEGATIVE EFFECTS, MAINLY INDIRECT LAND USE CHANGE (LUC), WHICH CAN UNDERMINE THE ENVIRONMENTAL BENEFITS OF BIOENERGY.
- 14 THE CALCULATION MUST INCLUDE EMISSIONS FROM CULTIVATION, EXTRACTION, PROCESSING, STORAGE, TRANSPORT, AND SMOKESTACK EMISSIONS (BURNING BIOMASS IS NOT CARBON NEUTRAL). WHEN BURNING BIOMASS, THE NET GREENHOUSE GAS EMISSIONS OVER A PERIOD OF 20 YEARS MUST BE ACCOUNTED FOR, AGAINST THE REFERENCE SCENARIO OF NOT USING THE BIOMASS FOR BIOENERGY.
- 15 GRASSLANDS STORE APPROXIMATELY 34% OF THE GLOBAL STOCK OF CARBON IN TERRESTRIAL ECOSYSTEMS WHILE FORESTS STORE APPROXIMATELY 39%.
- 16 GREENPEACE (2013). IDENTIFYING HIGH CARBON STOCK (HCS) FOREST FOR PROTECTION, HTTP://M.GREENPEACE.ORG/INTERNATIONAL/GLOBAL/INTERNATIONAL/BRIEFINGS/FORESTS/2013/HCS-BRIEFING-2013.PDF
- 17 AT THIS MOMENT, ONLY THE FSC PRINCIPLES AND CRITERIA ARE SUFFICIENT TO GUARANTEE RESPONSIBLE MANAGEMENT OF FORESTS. SEE WWW.FSC.ORG. THIS APPLIES TO ALL WOOD PRODUCTS, WHETHER BIOENERGY IS INVOLVED OR NOT.
- 18 OBVIOUSLY THIS APPLIES TO ALL AGRICULTURE, WHETHER BIOENERGY PRODUCTION IS INVOLVED OR NOT.
- 19 UNITED NATIONS (UN) COMMITTEE ON WORLD FOOD SECURITY (CFS) (2012), VOLUNTARY GUIDELINES ON THE RESPONSIBLE GOVERNANCE OF TENURE OF LAND, FISHERIES AND FORESTS IN THE CONTEXT OF NATIONAL FOOD SECURITY, HTTP://WWW.FAO.ORG/CFS/CFS-HOME/CFS-LAND-TENURE/EN/.
- 20 INTERNATIONAL LABOUR ORGANIZATION (ILO), INTERNATIONAL LABOUR STANDARDS, HTTP://WWW.ILO.ORG/GLOBAL/STANDARDS/LANG--EN/INDEX.HTM.
- 15 (STATISTICA 2015); ONLINE STATISTICAL RESEARCH TOOL; HTTP://WWW.STATISTA.COM/STATISTICS/263905/EVOLUTION-OF-THE-HUB-HEIGHT-OF-GERMAN-WIND-TURBINES/.
- 16 (EWEA 2014) WIND ENERGY SCENARIOS FOR 2020; EUROPEAN WIND ENERGY ASSOCIATION; JULY 2014; WWW.EWEA.ORG.
- 17 (GWEC, 2015) GLOBAL WIND REPORT 2014 – ANNUAL MARKET UPDATE; GLOBAL WIND ENERGY COUNCIL, BRUSSELS/BELGIUM, WWW.GWEC.NET ; MARCH 2015.
- 18 CARBON TRUST, 2008B; SNYDER AND KAISER, 2009B; TWIDELL AND GAUDIOSI, 2009.
- 19 (EWEA, 2010A).
- 20 MUSIAL, 2007; CARBON TRUST, 2008B.
- 21 (GOWEF 2014); COST REDUCTION POTENTIALS OF OFFSHORE WIND POWER IN GERMANY; PROGNOSE / FICHTNER, COMMISSIONED BY: THE GERMAN OFFSHORE WIND ENERGY FOUNDATION; ANDREAS WAGNER; OLDENBURGER STR. 65; 26316 VAREL; GERMANY; WWW.OFFSHORESTIFTUNG.DE
- 22 (EWEA-7-2013); DEEP WATER - THE NEXT STEP FOR OFFSHORE WIND ENERGY; EUROPEAN WIND ENERGY ASSOCIATION - JULY 2013; ISBN: 978-2-930670-04-1.
- 23 (IPCC-AR5-SPM) INTERNATIONAL PANEL ON CLIMATE CHANGE – 5TH ASSESSMENT REPORT; CLIMATE CHANGE 2014, SUMMARY FOR POLICY MAKERS; HTTP://IPCC.CH/PDF/ASSESSMENT-REPORT/AR5/SYR/AR5\_SYR\_FINAL\_SPM.PDF
- 24 (FAAJ 2006).
- 25 (YOKOYAMA AND MATSUMURA 2008).
- 26 (KIRKELS AND VERBONG 2011).
- 27 (IEA BIO-2009) BIOENERGY – A SUSTAINABLE AND RELIABLE ENERGY SOURCE MAIN REPORT; INTERNATIONAL ENERGY AGENCY 2009.
- 28 (IPCC-SRREN 2012); CHAPTER 4 GEOTHERMAL ENERGY.
- 29 ARMSTEAD AND TESTER, 1987; DICKSON AND FANELLI, 2003; DIPIPPO, 2008.
- 30 IPCC, SRREN 2012.
- 31 GRANT ET AL., 1982.
- 32 HJARTARSON AND EINARSSON, 2010.
- 33 LUND AND BOYD, 2009.
- 34 TESTER ET AL., 2006.
- 35 EGRE AND MILEWSKI, 2002.
- 36 (IRENA-HYDRO 2015) HYDROPOWER – TECHNOLOGY BRIEF; IEA-ETSAP AND IRENA TECHNOLOGY BRIEF E06 – FEBRUARY 2015. WWW.ETSAP.ORG – WWW.IRENA.ORG; INTERNATIONAL RENEWABLE ENERGY AGENCY (IRENA); ENERGY TECHNOLOGY SYSTEMS ANALYSIS PROGRAMME.
- 37 (IPCC-SRREN 2012), CHAPTER 6.
- 38 (KHAN ET AL., 2009).
- 39 FALCAO, 2009; KHAN AND BHUYAN, 2009; US DOE, 2010.
- 40 FALCAO ET AL., 2000; FALCAO, 2009.
- 41 FALCAO, 2009.
- 42 FALCAO, 2009.
- 43 KHAN AND BHUYAN, 2009.
- 44 BOSCH, 1997.
- 45 ANDRE, 1976; DE LALEU, 2009.
- 46 PAIK, 2008.
- 47 CHARLIER, 2003; ETSAP 2010B.
- 48 ENGINEERING BUSINESS, 2003; TSB, 2010.
- 49 PEYRARD ET AL. 2006.
- 50 VANZWIETEN ET AL., 2005.
- 51 VENEZIA AND HOLT, 1995; RAYE, 2001; VANZWIETEN ET AL., 2005.
- 52 (GPI-EN 2014) POWER [R] 2030 - A EUROPEAN GRID FOR 3/4 RENEWABLE ELECTRICITY BY 2030; GREENPEACE INTERNATIONAL / ENERGYNAUTICS; MARCH 2014.
- 53 HVAC CABLE SYSTEMS ARE CURRENTLY LESS ATTRACTIVE AS CABLE LOSSES ARE HIGHER AND TRANSMISSION CAPACITY IS LESS THAN WITH HVAC OVERHEAD LINES.
- 54 WEISS, W. ET AL. (2011); SOLAR HEAT WORLDWIDE - MARKETS AND CONTRIBUTION TO THE ENERGY SUPPLY 2009. IEA SOLAR HEATING AND COOLING PROGRAMME, MAY 2011. INTERNATIONAL ENERGY AGENCY (IEA), PARIS, FRANCE.
- 55 WEISS, W., ET AL. (2008); PROCESS HEAT COLLECTORS – STATE OF THE ART. IEA HEATING AND COOLING PROGRAMME AND IEA SOLARPACES PROGRAMME, 2008. INTERNATIONAL ENERGY AGENCY (IEA), PARIS, FRANCE.
- 56 TRAVASAROS, C. (2011); THE GREEK SOLAR THERMAL MARKET AND INDUSTRIAL APPLICATIONS - OVERVIEW OF THE MARKET SITUATION. GREEK SOLAR INDUSTRY ASSOCIATION, WORLD SUSTAINABLE ENERGY DAYS 2011, WELS, 3.3.2011, HTTP://WWW.WSED.AT/FILEADMIN/REDAKTEUR/WSED/2011/DOWNLOAD\_PRESENTATIONS/TRAVASAROS.PDF.
- 57 WEISS, W. ET AL. (2011); SOLAR HEAT WORLDWIDE - MARKETS AND CONTRIBUTION TO THE ENERGY SUPPLY 2009. IEA SOLAR HEATING AND COOLING PROGRAMME, MAY 2011. INTERNATIONAL ENERGY AGENCY (IEA), PARIS, FRANCE.
- 58 WEISS, W. ET AL. (2011); SOLAR HEAT WORLDWIDE - MARKETS AND CONTRIBUTION TO THE ENERGY SUPPLY 2009. IEA SOLAR HEATING AND COOLING PROGRAMME, MAY 2011. INTERNATIONAL ENERGY AGENCY (IEA), PARIS, FRANCE.
- 59 NITSCH, J. ET AL. (2010); LEITSTUDIÉ 2010 - LANGFRISTSZENARIEN UND STRATEGIEN FÜR DEN AUSBAU DER ERNEUERBAREN ENERGIEN IN DEUTSCHLAND BEI BERÜCKSICHTIGUNG DER ENTWICKLUNG IN EUROPA UND GLOBAL. STUTTGART, KASSEL, TELTOW, DEUTSCHES ZENTRUM FÜR LUFT- UND RAUMFAHRT, FRAUNHOFER INSTITUT FÜR WINDENERGIE UND ENERGIESYSTEMTECHNIK (IWES), INGENIEURBÜRO FÜR NEUE ENERGIEN (IFNE).
- 60 JAGER, D. ET AL. (2011); FINANCING RENEWABLE ENERGY IN THE EUROPEAN ENERGY MARKET. BRUSSELS, ECOFYS NL, FRAUNHOFER ISI, TU VIENNA EEG, ERNST & YOUNG, EUROPEAN COMMISSION (DG ENERGY).
- 61 WEISS, W., ET AL. (2008); PROCESS HEAT COLLECTORS – STATE OF THE ART. IEA HEATING AND COOLING PROGRAMME AND IEA SOLARPACES PROGRAMME, 2008. INTERNATIONAL ENERGY AGENCY (IEA), PARIS, FRANCE.
- 62 IPCC 2012; SPECIAL REPORT ON RENEWABLE ENERGY SOURCES AND CLIMATE CHANGE MITIGATION.
- 63 (IEA-ETN 2014) APPLICATION OF INDUSTRIAL HEAT PUMPS; FINAL REPORT; IEA HEAT PUMP CENTRE; BORÅS; SWEDEN; 2014.
- 64 GEMIS (2011); GLOBALES EMISSIONS-MODELL INTEGRIERTER SYSTEME (GEMIS), VERSION 4.6, ÖKO-INSTITUT.
- 65 NITSCH, J. ET AL. (2010); LEITSTUDIÉ 2010 - LANGFRISTSZENARIEN UND STRATEGIEN FÜR DEN AUSBAU DER ERNEUERBAREN ENERGIEN IN DEUTSCHLAND BEI BERÜCKSICHTIGUNG DER ENTWICKLUNG IN EUROPA UND GLOBAL. STUTTGART, KASSEL, TELTOW, DEUTSCHES ZENTRUM FÜR LUFT- UND RAUMFAHRT, FRAUNHOFER INSTITUT FÜR WINDENERGIE UND ENERGIESYSTEMTECHNIK (IWES), INGENIEURBÜRO FÜR NEUE ENERGIEN (IFNE).
- 66 GEMIS (2011); GLOBALES EMISSIONS-MODELL INTEGRIERTER SYSTEME (GEMIS), VERSION 4.6, ÖKO-INSTITUT.
- 67 AEBIOM (2011B); REVIEW OF INVESTMENT COST DATA FOR BIOMASS HEATING TECHNOLOGIES. G. A. CENTER, BRUSSELS.
- 68 KALTSCHMITT, M. ET AL., EDS. (2009); ENERGIE AUS BIOMASSE - GRUNDLAGEN, TECHNIKEN UND VERFAHREN. BERLIN, HEIDELBERG, SPRINGER.

## CHAPTER 10

- 1 (IEA 2015) ENERGY CLIMATE AND CHANGE; WORLD ENERGY OUTLOOK SPECIAL REPORT 2015; INTERNATIONAL ENERGY AGENCY, 9 RUE DE LA FÉDÉRATION, 75739 PARIS CEDEX 15, JUNE 2015.
- 2 (IEA-COAL ONLINE 2011) HTTP://WWW.COALONLINE.ORG/SITE/COALONLINE/CONTENT/VIEWER?LOGDOCID=81996&PHYDOCID=7800&FILENAME=780000023.HTML
- 3 (WCA 2015) WORLD COAL ASSOCIATION 2015; HTTP://WWW.WORLDCOAL.ORG/COAL-THE-ENVIRONMENT/COAL-USE-THE-ENVIRONMENT/IMPROVING-EFFICIENCIES/
- 4 (IEA-ETP 2014) ENERGY TECHNOLOGY PERSPECTIVE – HARNESSING ELECTRICITIES POTENTIAL; IEA MAY 2014.
- 5 (IEA TCEP 2015); TRACKING CLEAN ENERGY PROGRESS 2015 - ENERGY TECHNOLOGY PERSPECTIVES 2015, IEA INPUT TO THE CLEAN ENERGY MINISTERIAL, JUNE 2015.
- 6 (TESKE – CCS 1) LEAD AUTHORS OWN CALCULATION: 32.3 BN TONNES CO<sub>2</sub> / 8760H = 3.6 BN TONNES /H (GPI-FH 2008) "FALSE HOPE"; GREENPEACE INTERNATIONAL; EMILY ROCHON ET. AL.; MAY 2008; GREENPEACE INTERNATIONAL; OTTHO HELDRINGSTRAAT 5; 1066 AZ AMSTERDAM; THE NETHERLANDS.
- 7 (SCHEIDER/FROGGATT 2015) THE WORLD NUCLEAR INDUSTRY – STATUS REPORT 2015; PARIS, LONDON, JULY 2015; © A MYCLE SCHNEIDER CONSULTING PROJECT.
- 8 (IAEA 2004; WNO 2004).
- 9 (HOFFMANN/TESKE 2012) PREPARATION FOR EPIA/GREENPEACE SOLARGENERATION REPORT SERIES (EDITION 1 – V).
- 10 (EPIA 2011) SOLARGENERATION 6 – EPIA-GREENPEACE REPORT; EUROPEAN PHOTOVOLTAIC INDUSTRY ASSOCIATION (EPIA); GPI, BRUSSELS / AMSTERDAM; 2011.
- 11 (ESTELA 2015) CONCENTRATED SOLAR POWER OUTLOOK 2015; EUROPEAN SOLAR THERMAL ELECTRIC ASSOCIATION; BRUSSELS SEPTEMBER 2015.
- 12 (EWEA 2009) WIND ENERGY – THE FACTS; EUROPEAN WIND ENERGY ASSOCIATION; BRUSSELS/BELGIUM ; HTTP://WWW.WIND-ENERGY-THE-FACTS.ORG.
- 13 EWEA 2009.

69 IEA (2011B): COGENERATION AND RENEWABLES. INTERNATIONAL ENERGY AGENCY (IEA), PARIS, FRANCE.

70 KALTSCHMITT, M. ET AL., EDS. (2009): ENERGIE AUS BIOMASSE - GRUNDLAGEN, TECHNIKEN UND VERFAHREN. BERLIN, HEIDELBERG, SPRINGER.

71 KALTSCHMITT, M. ET AL., EDS. (2009): ENERGIE AUS BIOMASSE - GRUNDLAGEN, TECHNIKEN UND VERFAHREN. BERLIN, HEIDELBERG, SPRINGER.

72 PEHNT, M. ET AL. (2007): BIOMASSE UND EFFIZIENZ - VORSCHLÄGE ZUR ERHÖHUNG DER ENERGIEEFFIZIENZ VON §8 UND §7-ANLAGEN IM ERNEUERBARE-ENERGIEN-GESETZ. ARBEITSPAPIER NR. 1 IM RAHMEN DES PROJEKTES "ENERGIEBALANCE - OPTIMALE SYSTEMLÖSUNGEN FÜR ERNEUERBARE ENERGIEN UND ENERGIEEFFIZIENZ". HEIDELBERG, INSTITUT FÜR ENERGIE UND UMWELTFORSCHUNG HEIDELBERG GMBH (IFEU).

73 IEA (2007): RENEWABLES FOR HEATING AND COOLING. INTERNATIONAL ENERGY AGENCY (IEA), PARIS, FRANCE.

NITSCH, J. ET AL. (2010): LEITSTUDIE 2010 - LANGFRISTSZENARIEN UND STRATEGIEN FÜR DEN AUSBAU DER ERNEUERBAREN ENERGIEN IN DEUTSCHLAND BEI BERÜCKSICHTIGUNG DER ENTWICKLUNG IN EUROPA UND GLOBAL. STUTTGART, KASSEL, Teltow, DEUTSCHES ZENTRUM FÜR LUFT- UND RAUMFAHRT, FRAUNHOFER INSTITUT FÜR WINDENERGIE UND ENERGIESYSTEMTECHNIK (IWES), INGENIEURBÜRO FÜR NEUE ENERGIEN (IFNE).

74 DBFZ (2010): MONITORING ZUR WIRKUNG DES ERNEUERBARE-ENERGIEN-GESETZES (EEG) AUF DIE ENTWICKLUNG DER STROMERZEUGUNG AUS BIOMASSE (UNVERÖFFENTLICHTER ENTWURF). LEIPZIG, DEUTSCHES BIOMASSEFORSCHUNGSZENTRUM.

75 GÄRTNER, S. ET AL. (2008): OPTIMIERUNGEN FÜR EINEN NACHHALTIGEN AUSBAU DER BIOGASERZEUGUNG UND -NUTZUNG IN DEUTSCHLAND, MATERIALBAND E: ÖKOBLANZEN. HEIDELBERG, INSTITUT FÜR ENERGIE- UND UMWELTFORSCHUNG.

76 (F-IWS 2010) FRAUNHOFER IWS, ERNEUERBARES METHAN KOPPLUNG VON STROM- UND GASNETZ M.SC. MAREIKE JENTSCH, DR. MICHAEL STERNER (IWES), DR. MICHAEL SPECHT (ZSW), TUI CHEMNIKTZ, SPEICHERWERKSHOP CHEMNITZ, 28.10.2010.

77 (DLR-WAGNER 2015) DR. RER.NAT. NORBERT WAGNER; [HTTP://WWW.DLR.DE/TN/EN/DESKTOPDEFAULT.ASPX/TABID-7197/](http://www.dlr.de/tn/en/desktopdefault.aspx/tabid-7197/)

78 (IRENA - STORAGE 2015) RENEWABLES AND ELECTRICITY STORAGE - A TECHNOLOGY ROADMAP; INTERNATIONAL RENEWABLE ENERGY AGENCY (IRENA) IRENA INNOVATION AND TECHNOLOGY CENTRE; ROBER T-SCHUMAN-PLATZ 3; 53175 BONN; GERMANY; JUNE 2015

CHAPTER 11

1 (GRAUS ET AL. 2012); ENERGY DEMAND PROJECTIONS FOR ENERGY [R]EVOLUTION 2012; WINA GRAUS; KATERINA KERMELE; UTRECHT UNIVERSITY, MARCH 2012; COMMISSIONED BY: GREENPEACE INTERNATIONAL AND DLR; [HTTP://WWW.ENERGYBLUEPRINT.INFO/1432.0.HTML](http://www.energyblueprint.info/1432.0.html)

2 (IEA WEO 2014); WORLD ENERGY OUTLOOK 2014, INTERNATIONAL ENERGY AGENCY.

3 (DLR 2015); PROJECT REPORT; ALTERNATIVE TRANSPORT TECHNOLOGIES FOR MEGACITIES; GERMAN AEROSPACE CENTER (DLR), INSTITUTE OF VEHICLE CONCEPTS (DLR-FK), STUTTGART, GERMANY; 27 FEBRUARY 2015.

4 (IEA 2014); INTERNATIONAL ENERGY AGENCY (IEA), PARIS: ENERGY BALANCES OF OECD COUNTRIES AND ENERGY BALANCES OF NON-OECD COUNTRIES, 2014 EDITION. [HTTP://DATA.IEA.ORG](http://data.iea.org)

5 IEA (2007) ENERGY USE IN THE NEW MILLENNIUM - TRENDS IN IEA COUNTRIES. OECD/INTERNATIONAL ENERGY AGENCY.

IPCC (2007) FOURTH ASSESSMENT REPORT. WORKING GROUP III: MITIGATION OF CLIMATE CHANGE. CAMBRIDGE UNIVERSITY PRESS.

IEA (2009) ENERGY TECHNOLOGY TRANSITIONS FOR INDUSTRY: STRATEGIES FOR THE NEXT INDUSTRIAL REVOLUTION. PARIS, FRANCE: OECD/IEA, 2009.

6 (UNIUTRECHT 2013); BACKGROUND MATERIAL ABOUT THE ENERGY INTENSIVE INDUSTRIES IN THE 30 % DEBATE; FOR INTERNAL USE WITHIN GREENPEACE; WINA GRAUS (UU); MIRJAM HARMELINK (HARMELINK CONSULTING); DIAN PHYLIPSEN (PHYLIPSEN CLIMATE CHANGE CONSULTING); MARIËLLE CORSTEN (UU); JUNE 2013.

7 (REEEP 2008) GLOBAL STATUS REPORT ON ENERGY EFFICIENCY 2008.

8 (IEA 2008A) WORLD TRENDS IN ENERGY USE AND EFFICIENCY - KEY INSIGHTS FROM IEA INDICATOR ANALYSIS. INTERNATIONAL ENERGY AGENCY, PARIS.

9 (IEA 2007). TRACKING INDUSTRIAL ENERGY EFFICIENCY AND CO<sub>2</sub> EMISSIONS. INTERNATIONAL ENERGY AGENCY, PARIS, FRANCE.

10 (IEA ETP 2015); ENERGY TECHNOLOGY PERSPECTIVES 2015 - TRACKING CLEAN ENERGY PROCESS; INTERNATIONAL ENERGY AGENCY; JUNE 2015.

11 THIS IS BASED ON A NUMBER OF ZERO-ENERGY DWELLING IN THE NETHERLANDS AND GERMANY, CONSUMING 400-500 M3 NATURAL GAS PER YEAR, WITH A FLOOR SURFACE BETWEEN 120 AND 150 M2. THIS RESULTS IN 0.1 GJ/M2/YR AND IS CONVERTED BY 3100 HEATING DEGREE DAYS TO 32 KJ/M2/HDD.

12 WBCSD (WORLD BUSINESS COUNCIL ON SUSTAINABLE DEVELOPMENT) (2005). PATHWAYS TO 2050 - ENERGY AND CLIMATE CHANGE. IEA (2006). ENERGY TECHNOLOGY PERSPECTIVES - SCENARIOS AND STRATEGIES TO 2050. OECD/IEA, 2006.

13 BETTGENHÄUSER, K., T. BOERMANS AND S. SCHIMSCHAR (2009) SECTORAL EMISSION REDUCTION POTENTIALS AND ECONOMIC COSTS FOR CLIMATE CHANGE (SERPEC-CC). RESIDENTIAL BUILDINGS AND SERVICE SECTOR. ECOFYS, NETHERLANDS.

14 ENVIROHARVEST (2008) HEAT RECOVERY. [HTTP://WWW.ENVIROHARVEST.CA/HEAT\\_RECOVERY.HTM](http://www.enviroharvest.ca/heat_recovery.htm)

15 BETTGENHÄUSER, K., T. BOERMANS AND S. SCHIMSCHAR (2009) SECTORAL EMISSION REDUCTION POTENTIALS AND ECONOMIC COSTS FOR CLIMATE CHANGE (SERPEC-CC). RESIDENTIAL BUILDINGS AND SERVICE SECTOR. ECOFYS, NETHERLANDS.

16 REEEP (2009) IMPLEMENTATION OF A DISSEMINATION STRATEGY FOR EFFICIENT COOK STOVES IN NORTHEAST BRAZIL.

17 (EHPA 2014) EUROPEAN HEAT PUMP MARKET AND STATISTICS REPORT - EUROPEAN HEAT PUMP ASSOCIATION.

18 HENDEL-BLACKFORD, S., T. ANGELINI, S. OZAWA (2007) ENERGY EFFICIENCY IN LIFE-STYLES: EUROPE AND JAPAN. ECOFYS FOR EU-JAPAN CENTRE FOR INDUSTRIAL COOPERATION.

19 ENERGY STAR (2008) COMPACT FLUORESCENT LIGHT BULBS. [HTTP://WWW.ENERGYSTAR.GOV/INDEX.CFM?C=CFLS.PR\\_CFLS](http://www.energystar.gov/index.cfm?c=cfls_pr_cfls)

20 (USA-ENERGY-GOV 2014) ENERGY.GOV WEBSITE ([HTTP://ENERGY.GOV/ENERGYSAVER/ARTICLES/LED-LIGHTING](http://energy.gov/energysaver/articles/led-lighting)), U.S. DEPARTMENT OF ENERGY, 1000 INDEPENDENCE AVE. SW WASHINGTON DC 20585 / USA; NOVEMBER 2014.

21 IEA (2009B) GADGETS AND GIGAWATTS. INTERNATIONAL ENERGY AGENCY, PARIS, FRANCE.

22 IEA (2003) COOL APPLIANCES - POLICY STRATEGIES FOR ENERGY EFFICIENT HOMES. [HTTPS://WWW.IEA.ORG/TEXTBASE/NPPDF/FREE/2000/COOL\\_APPLIANCE2003.PDF](https://www.iea.org/textbase/nppdf/free/2000/cool_appliance2003.pdf)

23 BETTGENHÄUSER ET AL. (2009).

24 US DOE EERE (UNITED STATES DEPARTMENT OF ENERGY; ENERGY EFFICIENCY AND RENEWABLE ENERGY) (2008) INVENTIONS & INNOVATION PROJECT FACT SHEET. HIGH ENERGY EFFICIENCY AIR CONDITIONING. [HTTP://WWW1.EERE.ENERGY.GOV/INVENTIONS/PDFS/NIMITZ.PDF](http://www1.eere.energy.gov/inventions/pdfs/nimitz.pdf)

25 DARLING, D. (2005) SOLAR COOLING. THE ENCYCLOPEDIA OF ALTERNATIVE ENERGY AND SUSTAINABLE LIVING. [HTTP://WWW.DAVIDDARLING.INFO/ENCYCLOPEDIA/S/AE\\_SOLAR\\_COOLING.HTML](http://www.daviddarling.info/encyclopedia/s/ae_solar_cooling.html)

26 AUSTRIAN ENERGY AGENCY, 2006 - NOTE THAT SOLAR COOLING AND GEOTHERMAL COOLING MAY REDUCE THE NEED FOR HIGH GRADE ENERGY SUCH AS NATURAL GAS AND ELECTRICITY. ON THE OTHER

HAND THEY INCREASE THE USE OF RENEWABLE ENERGY. THE ENERGY SAVINGS ACHIEVED BY REDUCING THE NEED OF HIGH GRADE ENERGY WILL BE PARTLY COMPENSATED BY AN INCREASE OF RENEWABLE ENERGY.

27 US EPA (UNITED STATES ENVIRONMENTAL PROTECTION AGENCY) (2007) COOL ROOFS. [HTTP://WWW.EPA.GOV/HEAT/SLD/STRATEGIES/COOLROOFS.HTML](http://www.epa.gov/heat/sld/strategies/coolroofs.html)

28 ACEEE (AMERICAN COUNCIL FOR AN ENERGY-EFFICIENT ECONOMY) (2007) CONSUMER GUIDE TO HOME ENERGY SAVINGS - COOLING EQUIPMENT. [HTTP://WWW.ACEEE.ORG/CONSUMERGUIDE/COOLING.HTM#REDUCE](http://www.aceee.org/consumerguide/cooling.htm#reduce)

CHAPTER 12

1 (IEA-WEO SR 2015); WORLD ENERGY OUTLOOK - SPECIAL REPORT 2015, INTERNATIONAL ENERGY AGENCY; JUNE 2015.

2 DLR 2012: PROJECT REPORT - TRANSPORT SCENARIO BUILDING IN THE E[R] 2012. PAGENKOPF, J., SCHMID, S., FRIESKE, B., GERMAN AEROSPACE CENTER (DLR), INSTITUTE OF VEHICLE CONCEPTS; STUTTGART, GERMANY.

3 (DLR 2015); PROJECT REPORT - ALTERNATIVE TRANSPORT TECHNOLOGIES FOR MEGACITIES; GERMAN AEROSPACE CENTER (DLR), INSTITUTE OF VEHICLE CONCEPTS; STUTTGART, GERMANY.

4 (EYRING ET AL 2005) EYRING, V., KÖHLER, H., LAUER, A., LEMPER, B. (2005): EMISSIONS FROM INTERNATIONAL SHIPPING: 2. IMPACT OF FUTURE TECHNOLOGIES ON SCENARIOS UNTIL 2050, JOURNAL OF GEOPHYSICAL RESEARCH, 110, D17305.

5 (FULTON 2004); FULTON, L. AND EADS, G. (2004); IEA/SMP MODEL DOCUMENTATION AND REFERENCE CASE PROJECTION, PUBLISHED BY WBCSD.

6 (GREENPEACE GERMANY 2015); GREENPEACE STRATEGY FOR GREEN MOBILITY; D. MOSER /GPD; GEHL ARCHITECTS DENMARK 2015.

7 GRUNDITZ, E. A. (2014). BEV POWERTRAIN COMPONENT SIZING WITH RESPECT TO PERFORMANCE, ENERGY CONSUMPTION AND DRIVING PATTERNS. DEPARTMENT OF ENERGY AND ENVIRONMENT, CHALMERS UNIVERSITY OF TECHNOLOGY LICENTIATE OF ENGINEERING.

8 LIENKAMP, M. (2014). STATUS OF ELECTRICAL MOBILITY 2014

9 WAGNER, R., N. PRESCHITSCHKEK, ET AL. (2013). "CURRENT RESEARCH TRENDS AND PROSPECTS AMONG THE VARIOUS MATERIALS AND DESIGNS USED IN LITHIUM-BASED BATTERIES." J APPL ELECTROCHEM 43: 481-496.

10 SAE OFF-HIGHWAY ENGINEERING ONLINE (2013). "ABB 'FLASH CHARGES' ELECTRIC BUS IN 15 S." RETRIEVED 20.01.2015, FROM [HTTP://ARTICLES.SAE.ORG/12293/](http://articles.sae.org/12293/).

11 EGV1 (2014). "UNPLUGGED - INDUCTIVE CHARGING FOR ELECTRIC VEHICLES (FEBRUARY 2014)." RETRIEVED 28.01.2015, FROM [HTTP://WWW.EGV1.EU/PROJECTS/13/38/UNPLUGGED-INDUCTIVE-CHARGING-FOR-ELECTRIC-VEHICLES-FEBRUARY-2014](http://www.egv1.eu/projects/13/38/unplugged-inductive-charging-for-electric-vehicles-february-2014).

12 FTA (2014B). REVIEW AND EVALUATION OF WIRELESS POWER TRANSFER (WPT) FOR ELECTRIC TRANSIT APPLICATIONS, FTA REPORT NO. 0060, FEDERAL TRANSIT ADMINISTRATION. F. T. A. U.S. DEPARTMENT OF TRANSPORTATION.

13 LI, J. L. F. (2013). "CASE STUDY OF EV CITY BUS OPERATIONS." FROM [HTTP://BESTAR.LBL.GOV/US-CHINA-WORKSHOP-2013/FILES/2013/04/JAN-LL-LITHIUM-FORCE.PDF](http://bestar.lbl.gov/us-china-workshop-2013/files/2013/04/jan-ll-lithium-force.pdf)

14 FORBES (2014). "TESLA'S BATTERY SWAP STATIONS WILL HELP IT REQUALIFY FOR ZEV CREDITS IN CALIFORNIA." RETRIEVED 20.01.2015, FROM [HTTP://WWW.FORBES.COM/SITES/GREATSPECULATIONS/2014/12/30/TESLAS-BATTERY-SWAP-STATIONS-WILL-HELP-IT-REQUALIFY-FOR-ZEV-CREDITS-IN-CALIFORNIA/](http://www.forbes.com/sites/greatspeculations/2014/12/30/teslas-battery-swap-stations-will-help-it-requalify-for-zev-credits-in-california/).

15 DEN BOER, E., S. AARNIK, ET AL. (2013). ZERO EMISSIONS TRUCKS - AN OVERVIEW OF STATE-OF-THE-ART TECHNOLOGIES AND THEIR POTENTIAL. DELFT, CE DELFT.

16 EICHLSEDER, H. AND M. KLELL (2012). WASSERSTOFF IN DER FAHRZEUGTECHNIK. SPRINGER.

17 FERRARI, C., S. OFFINGER, ET AL. (2012). STUDIE ZU RANGE EXTENDER KONZEPTEN FÜR DEN EINSATZ IN EINEM BATTERIEELEKTRISCHEN FAHRZEUG - REXEL. STUTTGART, DLR-FK.

18 ACCORDING TO (DLR 2012) FOR THE 2012 EDITION OF ENERGY [R]EVOLUTION - THE ADVANCED ENERGY [R]EVOLUTION INTRODUCES THE SAME EFFICIENCY TECHNOLOGIES FASTER.

19 (TAVASSY 2011); TAVASSY, L. AND VAN MEIJEREN, J. (2011): MODAL SHIFT TARGET FOR FREIGHT TRANSPORT ABOVE 300 KM: AN ASSESSMENT, DISCUSSION PAPER, 17TH ACEA SAG MEETING.

20 (NASA 2011) BRADLEY, M. AND DRONEY, C. (2011): SUBSONIC ULTRA GREEN AIRCRAFT RESEARCH: PHASE I FINAL REPORT, ISSUED BY NASA.

21 (AKERMAN 2005) AKERMAN, J. (2005): SUSTAINABLE AIR TRANSPORT - ON TRACK IN 2050. TRANSPORTATION RESEARCH PART D, 10, 1111-126.

22 (ICAO 2008): COMMITTEE ON AVIATION ENVIRONMENTAL PROTECTION (CAEP), STEERING GROUP MEETING. FESG CAEP/8 TRAFFIC AND FLEET FORECASTS.

23 TOSCA (2011): TECHNOLOGY OPPORTUNITIES AND STRATEGIES TOWARD CLIMATE-FRIENDLY TRANSPORT (REPORTS).

24 (FULTON & EADS 2004); FULTON, L. AND G. EADS. (2004) IEA/SMP MODEL DOCUMENTATION AND REFERENCE CASE PROJECTION. WORLD BUSINESS COUNCIL FOR SUSTAINABLE DEVELOPMENT (WBCSD). [HTTP://WWW.WBCSD.ORG/WEB/PUBLICATIONS/MOBILITY/SMP-MODEL-DOCUMENT.PDF](http://www.wbcd.org/web/publications/mobility/smp-model-document.pdf)

25 (WBCSD 2004) WORLD BUSINESS COUNCIL FOR SUSTAINABLE DEVELOPMENT.

26 (VAN ROMPUY 2010); GEERTS, S., VERWERF, B., VANTORRE, M. AND VAN ROMPUY, F. (2010): IMPROVING THE EFFICIENCY OF SMALL INLAND VESSELS. PROCEEDINGS OF THE EUROPEAN INLAND WATERWAY NAVIGATION CONFERENCE.

27 (ICCT 2012); ICCT (2011): REDUCING GREENHOUSE GAS EMISSIONS FROM SHIPS - COST EFFECTIVENESS OF AVAILABLE OPTIONS.

28 (EYRING ET AL. 2005).

29 (MARINTEK 2000); STUDY OF GREENHOUSE EMISSIONS FROM SHIPS, FINAL REPORT TO THE INTERNATIONAL MARITIME ORGANIZATION.

## 13.2 GLOSSARY OF COMMONLY USED TERMS AND ABBREVIATIONS

### TERM/UNIT/ABBREVIATION

CHP	Combined Heat and Power
CO <sub>2</sub>	Carbon dioxide, the main greenhouse gas
GDP	Gross Domestic Product (means of assessing a country's wealth)
PPP	Purchasing Power Parity (adjustment to GDP assessment to reflect comparable standard of living)
IEA	International Energy Agency
J	Joule, a measure of energy
kJ	Kilojoule = 1,000 Joules
MJ	Megajoule = 1 million Joules
GJ	Gigajoule = 1 billion Joules
PJ	Petajoule = 10 <sup>15</sup> Joules
EJ	Exajoule = 10 <sup>18</sup> Joules
W	Watt, measure of electrical capacity
kW	Kilowatt = 1,000 watts
MW	Megawatt = 1 million watts
GW	Gigawatt = 1 billion watts
TW	Terawatt = 10 <sup>12</sup> watts
kWh	Kilowatt-hour, measure of electrical output = 1,000 watt-hours
TWh	Terawatt-hour, or 10 <sup>12</sup> watt-hours
t	Tonnes, measure of weight
Gt	Gigatonnes = 1 billion tonnes

### CONVERSION FACTORS - FOSSIL FUELS

COAL	23.03	MJ/kg	1 cubic	0.0283 m <sup>3</sup>
LIGNITE	8.45	MJ/kg	1 barrel	159 liter
OIL	6.12	GJ/barrel	1 US gallon	3.785 liter
GAS	38000.00	kJ/m <sup>3</sup>	1 UK gallon	4.546 liter

### CONVERSION FACTORS - DIFFERENT ENERGY UNITS

FROM:	TO:	TJ	Gcal	Mtoe	Mbtu	GWh
		MULTIPLY BY	MULTIPLY BY	MULTIPLY BY	MULTIPLY BY	MULTIPLY BY
TJ		1	238.8	2.388 x 10 <sup>5</sup>	947.8	0.2778
Gcal		4.1868 x 10 <sup>-3</sup>	1	10 <sup>-7</sup>	3.968	1.163 x 10 <sup>-3</sup>
Mtoe		4.1868 x 10 <sup>4</sup>	10 <sup>7</sup>	1	3968 x 10 <sup>7</sup>	11630
Mbtu		1.0551 x 10 <sup>-3</sup>	0.252	2.52 x 10 <sup>-8</sup>	1	2.931 x 10 <sup>-4</sup>
GWh		3.6	860	8.6 x 10 <sup>-6</sup>	3412	1

### 13.2.1 DEFINITION OF SECTORS

The definition of different sectors follows the sectorial break down of the IEA World Energy Outlook series.

All definitions below from *IEA Key World Energy Statistics*.

#### Industry sector:

Consumption in the industry sector includes the following subsectors (energy used for transport by industry is not included -> see under "Transport")

- Iron and steel industry
- Chemical industry
- Non-metallic mineral products e.g. glass, ceramic, cement etc.
- Transport equipment
- Machinery
- Mining
- Food and tobacco
- Paper, pulp and print
- Wood and wood products (other than pulp and paper)
- Construction
- Textile and Leather

#### Transport sector:

The Transport sector includes all fuels from transport such as road, railway, aviation, domestic navigation. Fuel used for ocean, coastal and inland fishing is included in "Other Sectors"

#### Other sectors:

Other sectors cover agriculture, forestry, fishing, residential, commercial and public services

#### Non-energy use:

Covers use of other petroleum products such as paraffin waxes, lubricants, bitumen etc.

## LIST OF FIGURES

FIGURE 1.1	GLOBALY AVERAGED COMBINED LAND AND OCEAN SURFACE TEMPERATURE ANOMALY	19	FIGURE 6.1.5	GLOBAL: DEVELOPMENT OF FINAL ENERGY DEMAND FOR HEAT BY SECTOR IN THE ENERGY [R]EVOLUTION SCENARIOS	85
FIGURE 1.2	GLOBALY AVERAGED SEA LEVEL CHANGE	19	FIGURE 6.1.6	GLOBAL: DEVELOPMENT OF ELECTRICITY GENERATION STRUCTURE – REFERENCE, ENERGY [R]EVOLUTION, ADVANCED ENERGY [R]EVOLUTION SCENARIOS	85
FIGURE 1.3	GLOBALY AVERAGED GREENHOUSE GAS CONCENTRATIONS	19	FIGURE 6.1.7	GLOBAL: DEVELOPMENT OF TOTAL ELECTRICITY SUPPLY COSTS & OF SPECIFIC ELECTRICITY GENERATION COSTS IN THE SCENARIOS	87
FIGURE 1.4	GLOBALY ANTHROPOGENIC CO <sub>2</sub> EMISSIONS	19	FIGURE 6.1.8	GLOBAL: INVESTMENT SHARES - REFERENCE VERSUS ENERGY [R]EVOLUTION SCENARIOS	87
FIGURE 1.5	WIDESPREAD IMPACTS ATTRIBUTED TO CLIMATE CHANGE BASED ON THE AVAILABLE SCIENTIFIC LITERATURE SINCE THE AR4	21	FIGURE 6.1.9	GLOBAL: PROJECTION OF HEAT SUPPLY BY ENERGY CARRIER – REFERENCE, ENERGY [R]EVOLUTION, ADVANCED ENERGY [R]EVOLUTION SCENARIOS	88
FIGURE 3.1	ESTIMATED RENEWABLE ENERGY SHARE OF GLOBAL FINAL ENERGY CONSUMPTION 2013	39	FIGURE 6.1.10	GLOBAL: DEVELOPMENT OF INVESTMENTS FOR RENEWABLE HEAT GENERATION TECHNOLOGIES REFERENCE, ENERGY [R]EVOLUTION, ADVANCED ENERGY [R]EVOLUTION SCENARIOS	89
FIGURE 3.2	A DECENTRALISED ENERGY FUTURE	41	FIGURE 6.1.11	GLOBAL: EMPLOYMENT IN THE ENERGY SECTOR UNDER THE REFERENCE AND ENERGY [R]EVOLUTION SCENARIOS	90
FIGURE 3.3	THE EVOLVING APPROACH TO GRIDS	43	FIGURE 6.1.12	GLOBAL: GLOBAL PROPORTION OF FOSSIL FUEL AND RENEWABLE EMPLOYMENT IN 2015 AND 2030	90
FIGURE 3.4	THE SMART-GRID VISION FOR THE ENERGY [R]EVOLUTION	45	FIGURE 6.1.13	GLOBAL: FINAL ENERGY CONSUMPTION IN TRANSPORT UNDER THE SCENARIOS	91
FIGURE 3.5	CHANGING VALUE CHAIN FOR PLANNING, CONSTRUCTION AND OPERATION OF NEW POWER PLANTS	46	FIGURE 6.1.14	GLOBAL: PROJECTION OF TOTAL PRIMARY ENERGY DEMAND (PED) BY ENERGY CARRIER	92
FIGURE 3.6	ADD FIGURE CUSTOMER STRUCTURE BY VOLTAGE LEVEL	47	FIGURE 6.1.15	GLOBAL: DEVELOPMENT OF CO <sub>2</sub> EMISSIONS BY SECTOR UNDER THE ENERGY [R]EVOLUTION SCENARIOS	92
FIGURE 4.1	RETURN CHARACTERISTICS OF RENEWABLE ENERGIES	50	FIGURES 6.2.1-6.2.13	OECD NORTH AMERICA	94-103
FIGURE 4.2	OVERVIEW RISK FACTORS FOR RENEWABLE ENERGY PROJECTS	51	FIGURES 6.3.1-6.3.13	LATIN AMERICA	104-113
FIGURE 4.3	INVESTMENT STAGES OF RENEWABLE ENERGY PROJECTS	51	FIGURES 6.4.1-6.4.13	OECD EUROPE	114-123
FIGURE 4.4	KEY BARRIERS TO RE INVESTMENT	53	FIGURES 6.5.1-6.5.13	AFRICA	124-133
FIGURE 4.5	GLOBAL NEW INVESTMENT IN RENEWABLE POWER AND FUELS, DEVELOPED AND DEVELOPING COUNTRIES, 2004–2014	54	FIGURES 6.6.1-6.6.13	MIDDLE EAST	134-143
FIGURE 4.6	GLOBAL NEW INVESTMENT IN RENEWABLE POWER AND FUELS, BY REGION 2001-2014	55	FIGURES 6.7.1-6.7.13	EASTERN EUROPE/EURASIA	144-153
FIGURE 4.7	INVESTMENT CATEGORIES – DEFINITION BY BLOOMBERG NEW ENERGY FINANCE 2015	56	FIGURES 6.8.1-6.8.13	INDIA	154-163
FIGURE 4.8	GLOBAL NEW INVESTMENT IN RENEWABLE ENERGY BY ASSET CLASS, 2004–147	57	FIGURES 6.9.1-6.9.13	OTHER ASIA	164-173
FIGURE 5.1	FUTURE DEVELOPMENT OF INVESTMENT COSTS FOR RENEWABLE ENERGY TECHNOLOGIES	71	FIGURES 6.10.1-6.10.13	CHINA	174-183
FIGURE 5.2	EXPECTED DEVELOPMENT OF ELECTRICITY GENERATION COSTS FROM RENEWABLE POWER GENERATION IN THE ENERGY [R]EVOLUTION SCENARIOS	71	FIGURES 6.11.1-6.11.13	OECD ASIA OCEANIA	184-193
FIGURE 5.3	GLOBAL OIL PRODUCTION 1950 – 2011 AND PROJECTIONS UNTIL 2050	75	FIGURE 7.1	METHODOLOGY OVERVIEW	195
FIGURE 5.4	COAL SCENARIO: BASE DECLINE OF 2% PER YEAR AND NEW PROJECTS	75	FIGURE 8.1	GLOBAL ANNUAL POWER PLANT MARKET 1970 - 2014	205
FIGURE 5.5	WIND POWER – SHORT TERM PROGNOSIS VS REAL DEVELOPMENT – GLOBAL CUMULATIVE CAPACITY	76	FIGURE 8.2	GLOBAL ANNUAL POWER PLANT MARKET – EXCLUDING CHINA: 1970 - 2014	206
FIGURE 5.6	WIND POWER – LONG TERM MARKET PROJECTIONS UNTIL 2030	77	FIGURE 8.3	USA ANNUAL POWER PLANT MARKET: 1970 - 2014	207
FIGURE 5.7	SOLAR PHOTOVOLTAIC– SHORT TERM PROGNOSIS VS REAL DEVELOPMENT – GLOBAL CUMULATIVE CAPACITY	79	FIGURE 8.4	EU ANNUAL POWER PLANT MARKET: 1970 - 2014	208
FIGURE 5.8	SOLAR PHOTOVOLTAIC – LONG TERM MARKET PROJECTIONS UNTIL 2030	80	FIGURE 8.5	CHINA ANNUAL POWER PLANT MARKET: 1970 - 2014	209
FIGURE 6.1.1	GLOBAL: FINAL ENERGY INTENSITY UNDER THE REFERENCE AND BOTH ENERGY [R]EVOLUTION SCENARIOS	83	FIGURE 8.6	GLOBAL AND REGIONAL POWER PLANT MARKET SHARES 2004 - 2014	210
FIGURE 6.1.2	GLOBAL: PROJECTION OF TOTAL FINAL ENERGY DEMAND BY SECTOR – REFERENCE, ENERGY [R]EVOLUTION, ADVANCED ENERGY [R]EVOLUTION SCENARIOS	84	FIGURE 8.7	ESTIMATED RENEWABLE ENERGY SHARE OF GLOBAL ELECTRICITY PRODUCTION, END-2014	212
FIGURE 6.1.3	GLOBAL: DEVELOPMENT OF ELECTRICITY DEMAND BY SECTOR IN THE ENERGY [R]EVOLUTION SCENARIOS	85	FIGURE 8.8	AVERAGE ANNUAL GROWTH RATES OF RENEWABLE ENERGY CAPACITY AND BIOFUELS PRODUCTION, END 2009–2014	213
FIGURE 6.1.4	GLOBAL: DEVELOPMENT OF THE FINAL ENERGY DEMAND FOR TRANSPORT BY SECTOR IN THE ENERGY [R]EVOLUTION SCENARIOS	85	FIGURE 9.1	GLOBALY AVERAGE COMBINED LAND AND OCEAN SURFACE TEMPERATURE ANOMALY	221
			FIGURE 9.2	RENEWABLE ENERGY POTENTIAL ANALYSIS	222



## LIST OF FIGURES CONTINUED

FIGURE 10.1	ILLUSTRATIVE SYSTEM FOR ENERGY PRODUCTION AND USE ILLUSTRATING THE ROLE OF RE ALONG WITH OTHER PRODUCTION OPTIONS	231	FIGURE 11.1	FINAL ENERGY DEMAND FOR THE WORLD BY SUB SECTOR AND FUEL SOURCE IN 2012	272
FIGURE 10.2	EXAMPLE OF THE PHOTOVOLTAIC EFFECT	232	FIGURE 11.2	BREAKDOWN OF FINAL ENERGY CONSUMPTION IN 2012 BY SUB SECTOR FOR INDUSTRY	272
FIGURE 10.3	PHOTOVOLTAIC TECHNOLOGY	232	FIGURE 11.3	BREAKDOWN OF ELECTRICITY USE IN OTHER SECTORS IN 2012	273
FIGURE 10.4	DIFFERENT CONFIGURATIONS OF SOLAR POWER SYSTEMS	234	FIGURE 11.4	BREAKDOWN OF FINAL ENERGY DEMAND IN 2012 FOR ELECTRICITY AND FUELS/HEAT IN OTHER SECTORS	273
FIGURE 10.5	CSP TECHNOLOGIES: PARABOLIC TROUGH, CENTRAL RECEIVER/SOLAR TOWER AND PARABOLIC DISH	236	FIGURE 11.5	BREAKDOWN OF FUEL AND HEAT USE IN OTHER SECTORS IN 2012	273
FIGURE 10.6	PRINCIPLE OF CSP SYSTEMS	237	FIGURE 11.6	BREAKDOWN OF ELECTRICITY USE BY SUB SECTOR IN OTHER SECTORS IN 2012	274
FIGURE 10.7	EWEA EARLY WIND TURBINE DESIGNS	238	FIGURE 11.7	FINAL ENERGY DEMAND IN THE REFERENCE SCENARIO PER SECTOR WORLDWIDE	274
FIGURE 10.8	BASIC COMPONENT OF WIND TURBINES WITHOUT GEARBOXES	239	FIGURE 11.8	FINAL ENERGY DEMAND IN THE REFERENCE SCENARIO PER REGION	275
FIGURE 10.9	GROWTH OF SIZE OF TYPICAL COMMERCIAL WIND TURBINES	239	FIGURE 11.9	FINAL ENERGY DEMAND PER CAPITA IN THE REFERENCE SCENARIO	275
FIGURE 10.10	OFFSHORE WIND FOUNDATION TECHNOLOGIES	240	FIGURE 11.10	ENERGY DEMAND IN INDUSTRY IN THE REFERENCE SCENARIO PER REGION	275
FIGURE 10.11	BIOGAS TECHNOLOGY	241	FIGURE 11.11	ENERGY DEMAND IN OTHER SECTORS IN THE REFERENCE SCENARIO PER REGION	276
FIGURE 10.12	SCHEMATIC VIEW OF COMMERCIAL BIOENERGY ROUTES	243	FIGURE 11.12	SHARE ELECTRICITY AND FUEL CONSUMPTION BY OTHER SECTORS IN TOTAL FINAL ENERGY DEMAND IN 2012 AND 2050 IN THE REFERENCE SCENARIO	276
FIGURE 10.13	GHG EMISSIONS OF BIOENERGY AND FOSSIL FUELS	244	FIGURE 11.13	ENERGY EFFICIENCY INDEX FOR IRON AND STEEL INDUSTRY PRIMARY ENERGY USE PER CAPITA	277
FIGURE 10.14	SCHEME SHOWING AN ENHANCED GEOTHERMAL SYSTEM (EGS)	246	FIGURE 11.14	SPECIFIC ENERGY CONSUMPTION IN AMMONIA (NH <sub>3</sub> ) PRODUCTION IN 1995 AND 2005	278
FIGURE 10.15	SCHEMATIC DIAGRAM OF A GEOTHERMAL CONDENSING STEAM POWER PLANT (TOP) AND A BINARY-CYCLE POWER PLANT (BOTTOM)	246	FIGURE 11.15	ELEMENTS OF NEW BUILDING DESIGN THAT CAN SUBSTANTIALLY REDUCE ENERGY USE	280
FIGURE 10.16	RUN-OF-RIVER HYDROPOWER PLANT	247	FIGURE 11.16	GLOBAL FINAL ENERGY USE IN THE PERIOD 2012-2050 IN INDUSTRY IN THE ENERGY [R]EVOLUTION AND THE REFERENCE DEMAND SCENARIO DISTINGUISHED BY ELECTRICITY AND FUELS/HEAT	282
FIGURE 10.17	TYPICAL HYDROPOWER PLANT WITH RESERVOIR	248	FIGURE 11.17	FINAL ENERGY USE IN SECTOR INDUSTRY IN THE ENERGY [R]EVOLUTION AND THE REFERENCE DEMAND SCENARIO DISTINGUISHED BY WORLD REGIONS	283
FIGURE 10.18	TYPICAL PUMPED STORAGE POWER PLANT	248	FIGURE 11.18	GLOBAL FINAL ENERGY USE IN THE PERIOD 2012-2050 IN OTHER SECTORS IN THE ENERGY [R]EVOLUTION AND THE REFERENCE SCENARIO DISTINGUISHED BY ELECTRICITY AND FUELS/HEAT	283
FIGURE 10.19	TYPICAL IN-STREAM HYDROPOWER PLANT	249	FIGURE 11.19	FINAL ENERGY USE IN OTHER SECTORS IN THE ENERGY [R]EVOLUTION AND THE REFERENCE SCENARIO DISTINGUISHED BY WORLD REGIONS	284
FIGURE 10.20	WAVE ENERGY: CLASSIFICATION BASED ON PRINCIPLES OF OPERATION	250	FIGURE 11.20	AVERAGE GLOBAL ENERGY INTENSITIES IN TRANSPORT – FINAL ENERGY PER \$ GDP IN THE ENERGY [R]EVOLUTION AND THE REFERENCE SCENARIO	285
FIGURE 10.21	OSCILLATING WATER COLUMNS	251	FIGURE 11.21	AVERAGE GLOBAL ENERGY INTENSITIES IN INDUSTRY – ELECTRICITY AND FUELS/HEAT DEMAND PER \$ GDP IN THE ENERGY [R]EVOLUTION AND THE REFERENCE SCENARIO	285
FIGURE 10.22	OSCILLATING-BODY SYSTEMS	251	FIGURE 11.22	AVERAGE GLOBAL ENERGY INTENSITIES IN OTHER SECTORS – ELECTRICITY AND FUELS/HEAT DEMAND PER CAPITA IN THE ENERGY [R]EVOLUTION AND THE REFERENCE SCENARIO	285
FIGURE 10.23	OVERTOPPING DEVICES	251	FIGURE 11.23	AVERAGE GLOBAL ENERGY INTENSITIES PER WORLD REGION – FINAL ENERGY PER CAPITA IN THE ENERGY [R]EVOLUTION SCENARIO	285
FIGURE 10.24	CLASSIFICATION OF CURRENT TIDAL AND OCEAN ENERGY TECHNOLOGIES (PRINCIPLES OF OPERATION)	252			
FIGURE 10.25	TWIN TURBINE HORIZONTAL AXIS DEVICE	253			
FIGURE 10.26	VERTICAL AXIS DEVICE	253			
FIGURE 10.27	CROSS FLOW DEVICE	253			
FIGURE 10.28	COMPARISON OF AC AND DC INVESTMENT COSTS USING OVERHEAD LINES	258			
FIGURE 10.29	COMPARISON OF THE REQUIRED NUMBER OF PARALLEL PYLONS AND SPACE TO TRANSFER 10 GW OF ELECTRIC CAPACITY	259			
FIGURE 10.30	NATURAL FLOW SYSTEMS VS. FORCED CIRCULATION SYSTEMS	260			
FIGURE 10.31	TWO MAIN TYPES OF DISTRICT HEATING SYSTEMS: TOP, OPEN LOOP (SINGLE PIPE SYSTEM), BOTTOM, CLOSED LOOP (DOUBLE PIPE SYSTEM)	263			
FIGURE 10.32	EXAMPLES FOR HEAT PUMP SYSTEMS	265			
FIGURE 10.33	OVERVIEW STORAGE CAPACITY OF DIFFERENT ENERGY STORAGE SYSTEMS	268			
FIGURE 10.34	RENEWABLE (POWER) (TO) METHANE - RENEWABLE GAS	269			
FIGURE 10.35	POTENTIAL LOCATIONS AND APPLICATIONS OF ELECTRICITY STORAGE IN THE POWER SYSTEM	269			

## LIST OF FIGURES CONTINUED

FIGURE 12.1	WORLD FINAL ENERGY USE PER TRANSPORT MODE 2012 – 2050 – REFERENCE SCENARIO	288
FIGURE 12.2	WORLD FINAL ENERGY USE BY REGION 2012 – 2050 – REFERENCE SCENARIO	289
FIGURE 12.3	SCHEMATIC ARCHITECTURE OF BATTERY ELECTRIC VEHICLES (BEV)	290
FIGURE 12.4	SCHEMATIC ARCHITECTURE OF FUEL CELL ELECTRIC VEHICLES (FCEV)	292
FIGURE 12.5	WORLD AVERAGE (STOCK-WEIGHTED) PASSENGER TRANSPORT ENERGY INTENSITIES FOR TODAY AND 2050	294
FIGURE 12.6	WORLD AVERAGE (STOCK-WEIGHTED) FREIGHT TRANSPORT ENERGY INTENSITIES FOR TODAY AND 2050	294
FIGURE 12.7	DEVELOPMENT OF TONNE-KM OVER TIME IN THE REFERENCE SCENARIO	295
FIGURE 12.8	ENERGY INTENSITIES (MJ/P-KM) FOR AIR TRANSPORT IN ENERGY [R]EVOLUTION SCENARIOS	296
FIGURE 12.9	DEVELOPMENT OF FINAL ENERGY USE FOR AVIATION BY TECHNOLOGIES IN THE REFERENCE AND BOTH ENERGY [R]EVOLUTION SCENARIOS	296
FIGURE 12.10	DEVELOPMENT OF FINAL ENERGY USE FOR RAIL TRANSPORT BY TECHNOLOGIES IN THE REFERENCE AND BOTH ENERGY [R]EVOLUTION SCENARIOS	297
FIGURE 12.11	DEVELOPMENT OF FINAL ENERGY USE FOR MARINE TRANSPORT BY TECHNOLOGIES IN THE REFERENCE AND BOTH ENERGY [R]EVOLUTION SCENARIOS	299
FIGURE 12.12	ENERGY INTENSITIES FOR LDV CURRENTLY AND UNDER THE ENERGY [R]EVOLUTION IN 2050	300
FIGURE 12.13	LDV OCCUPANCY RATES CURRENTLY AND UNDER THE ENERGY [R]EVOLUTION IN 2050	301
FIGURE 12.14	OVERVIEW ELECTRICITY DEMAND OF TRANSPORT TECHNOLOGIES PER 100 PASSENGER KILOMETERS	301
FIGURE 12.15	SALES SHARE OF CONVENTIONAL ICE, AUTONOMOUS HYBRID AND GRID-CONNECTABLE VEHICLES IN 2050	303
FIGURE 12.16	ASSUMED VEHICLE SALES BY SEGMENT CURRENTLY AND 2050 UNDER THE ENERGY [R]EVOLUTION	303
FIGURE 12.17	DEVELOPMENT OF THE AVERAGE ANNUAL LDV KILOMETRES DRIVEN PER WORLD REGION UNDER THE ENERGY [R]EVOLUTION	304
FIGURE 12.18	DEVELOPMENT OF FINAL ENERGY USE FOR ROAD TRANSPORT BY TECHNOLOGIES IN THE REFERENCE AND BOTH ENERGY [R]EVOLUTION SCENARIOS	305
FIGURE 12.19	WORLD FINAL ENERGY USE BY REGION 2012 – 2050 – ENERGY [R]EVOLUTION SCENARIOS	306

## LIST OF TABLES

TABLE 4.1	HOW DOES THE CURRENT RENEWABLE ENERGY MARKET WORK IN PRACTICE?	49	TABLE 6.8.1-6.8.13 INDIA	154-163
TABLE 4.2	CATEGORISATION OF BARRIERS TO RENEWABLE ENERGY INVESTMENT	52	TABLE 6.9.1-6.9.13 OTHER ASIA	164-173
TABLE 5.1	WORLD REGIONS USED IN THE SCENARIOS	62	TABLE 6.10.1-6.10.13 CHINA	174-183
TABLE 5.2	POPULATION DEVELOPMENT PROJECTIONS	65	TABLE 6.11.1-6.11.13 OECD ASIA OCEANIA	184-193
TABLE 5.3	GDP DEVELOPMENT PROJECTIONS - AVERAGE ANNUAL GROWTH RATES	65	TABLE 7.1	SUMMARY OF EMPLOYMENT FACTORS USED IN GLOBAL ANALYSIS 2015
TABLE 5.4	DEVELOPMENT PROJECTIONS FOR FOSSIL FUEL AND BIOMASS PRICES IN \$2010	66	TABLE 7.2	EMPLOYMENT FACTORS USED FOR COAL FUEL SUPPLY (MINING AND ASSOCIATED JOBS)
TABLE 5.5	DEVELOPMENT OF EFFICIENCY AND INVESTMENT COSTS FOR SELECTED NEW POWER PLANT TECHNOLOGIES; EXEMPLARY DATA FOR OECD EUROPE	67	TABLE 7.3	REGIONAL MULTIPLIERS
TABLE 5.6	PHOTOVOLTAICS (PV) COST ASSUMPTIONS	68	TABLE 7.4	FOSSIL FUELS AND NUCLEAR ENERGY: CAPACITY AND DIRECT JOBS
TABLE 5.7	CSP COST ASSUMPTIONS	69	TABLE 7.5	WINDPOWER: CAPACITY AND DIRECT JOBS
TABLE 5.8	WIND COST ASSUMPTIONS	69	TABLE 7.6	BIOMASS: CAPACITY AND DIRECT JOBS
TABLE 5.9	BIOMASS COST ASSUMPTIONS	70	TABLE 7.7	GEOTHERMAL: CAPACITY AND DIRECT JOBS
TABLE 5.10	GEOTHERMAL POWER COST ASSUMPTIONS	70	TABLE 7.8	WAVE AND TIDAL POWER: CAPACITY AND DIRECT JOBS
TABLE 5.11	OCEAN ENERGY COST ASSUMPTIONS	70	TABLE 7.9	SOLAR PHOTOVOLTAICS: CAPACITY AND DIRECT JOBS
TABLE 5.12	HYDRO POWER COST ASSUMPTIONS	71	TABLE 7.10	SOLAR THERMAL POWER: CAPACITY AND DIRECT JOBS
TABLE 5.13	OVERVIEW OF EXPECTED INVESTMENT AND OPERATION & MAINTENANCE COSTS PATHWAYS FOR HEATING TECHNOLOGIES IN EUROPE	73	TABLE 7.11	SOLAR HEATING: CAPACITY AND DIRECT JOBS
TABLE 5.14	ASSUMPTIONS FOR HYDROGEN AND SYN FUEL PRODUCTION	73	TABLE 7.12	GEOTHERMAL AND HEAT PUMP HEATING: CAPACITY AND DIRECT JOBS
TABLE 5.15	ASSUMED AVERAGE GROWTH RATES AND ANNUAL MARKET VOLUMES BY RENEWABLE TECHNOLOGY	74	TABLE 7.13	BIOMASS HEAT: DIRECT JOBS IN FUEL SUPPLY
TABLE 5.16	OVERVIEW OF KEY PARAMETERS OF THE ILLUSTRATIVE SCENARIOS BASED ON ASSUMPTIONS THAT ARE EXOGENOUS TO THE MODELS RESPECTIVE ENDOGENOUS MODEL RESULTS	81	TABLE 8.1	GLOBAL AND REGIONAL POWER PLANT MARKET SHARES
TABLE 6.1.1	GLOBAL: PROJECTION OF RENEWABLE ELECTRICITY GENERATION CAPACITY UNDER THE REFERENCE AND THE ENERGY [R]EVOLUTION SCENARIOS	86	TABLE 9.1	FOSSIL AND URANIUM RESERVES, RESOURCES AND OCCURRENCES
TABLE 6.1.2	GLOBAL: PROJECTION OF RENEWABLE HEAT SUPPLY UNDER THE REFERENCE AND BOTH ENERGY [R]EVOLUTION SCENARIOS IN PJ/A	88	TABLE 9.2	POTENTIAL EMISSIONS AS A CONSEQUENCE OF THE FOSSIL RESERVES AND RESOURCES
TABLE 6.1.3	GLOBAL: INSTALLED CAPACITIES FOR RENEWABLE HEAT GENERATION UNDER THE SCENARIOS IN GW	89	TABLE 9.3	ASSUMPTIONS ON FOSSIL FUEL USE IN THE ENERGY [R]EVOLUTION SCENARIO
TABLE 6.1.4	GLOBAL: TOTAL EMPLOYMENT IN THE ENERGY SECTOR IN MILLION JOBS	90	TABLE 9.4	RENEWABLE ENERGY POTENTIAL
TABLE 6.1.5	GLOBAL: PROJECTION OF TRANSPORT ENERGY DEMAND BY MODE IN THE REFERENCE AND THE ENERGY [R]EVOLUTION SCENARIOS IN PJ/A	91	TABLE 9.5	RENEWABLE ENERGY FLOWS, POTENTIAL AND UTILIZATION IN EJ OF INPUTS PROVIDED BY NATURE
TABLE 6.1.6	GLOBAL: ACCUMULATED INVESTMENT COSTS FOR ELECTRICITY GENERATION AND FUEL COST SAVINGS UNDER THE ENERGY [R]EVOLUTION SCENARIO COMPARED TO THE REFERENCE SCENARIO	93	TABLE 10.1	TYPICAL TYPE AND SIZE OF APPLICATIONS PER MARKET SEGMENT
TABLE 6.1.7	GLOBAL: ACCUMULATED INVESTMENT COSTS FOR RENEWABLE HEAT GENERATION UNDER THE ENERGY [R]EVOLUTION SCENARIO COMPARED TO THE REFERENCE SCENARIO	93	TABLE 10.2	OVERVIEW OF THE THREE MAIN TRANSMISSION SOLUTIONS
TABLE 6.1.8	GLOBAL: ACCUMULATED INVESTMENT COSTS FOR ELECTRICITY GENERATION AND FUEL COST SAVINGS UNDER THE ADVANCED ENERGY [R]EVOLUTION SCENARIO COMPARED TO THE REFERENCE SCENARIO	93	TABLE 11.1	ENERGY EFFICIENCY OF CHEMICAL AND PETROCHEMICAL INDUSTRY
TABLE 6.1.9	GLOBAL: ACCUMULATED INVESTMENT COSTS FOR RENEWABLE HEAT GENERATION UNDER THE ADVANCED ENERGY [R]EVOLUTION SCENARIO COMPARED TO THE REFERENCE SCENARIO	93	TABLE 11.2	ENERGY EFFICIENCY INDEX OF PULP AND PAPER PRODUCTION
TABLE 6.2.1-6.2.13	OECD NORTH AMERICA	94-103	TABLE 12.1	SELECTION OF MEASURES AND INDICATORS
TABLE 6.3.1-6.3.13	LATIN AMERICA	104-113	TABLE 12.2	OVERHEAD CATENARY AND THIRD RAIL SYSTEMS IN URBAN PUBLIC TRANSPORT APPLICATIONS
TABLE 6.4.1-6.4.13	OECD EUROPE	114-123	TABLE 12.3	AIR TRAFFIC SUBSTITUTION POTENTIAL OF HIGH SPEED RAIL (HSR)
TABLE 6.5.1-6.5.13	AFRICA	124-133	TABLE 12.4	THE WORLD AVERAGE ENERGY INTENSITIES FOR MDV AND HDV CURRENTLY AND 2050 ENERGY [R]EVOLUTION SCENARIO
TABLE 6.6.1-6.6.13	MIDDLE EAST	134-143	TABLE 12.5	TECHNICAL EFFICIENCY POTENTIAL FOR WORLD PASSENGER TRANSPORT
TABLE 6.7.1-6.7.13	EASTERN EUROPE/EURASIA	144-153	TABLE 12.6	TECHNICAL EFFICIENCY POTENTIAL FOR WORLD FREIGHT TRANSPORT
			TABLE 12.7	SELECTED PARAMETERS FOR VEHICLE TECHNOLOGIES FOR CITY APPLICATIONS
			TABLES	13.1.1-13.11.24 RESULTS DATA TABLES

# GLOBAL: REFERENCE SCENARIO

Table 13.1.1 Global: Electricity generation TWh/a

	2012	2020	2025	2030	2040	2050
<b>Power plants</b>	<b>19,125</b>	<b>24,639</b>	<b>28,392</b>	<b>32,169</b>	<b>39,767</b>	<b>45,752</b>
Hard coal (& non-renewable waste)	5,477	7,315	8,702	10,167	13,224	15,074
Lignite	1,718	1,897	2,044	2,143	2,380	2,617
Gas	3,876	4,614	5,865	6,710	9,020	10,759
<i>of which from H<sub>2</sub></i>	0	0	0	0	0	0
Oil	889	647	532	418	301	212
Diesel	147	158	180	202	234	256
Nuclear	2,450	3,215	3,443	3,670	3,856	4,054
Biomass (& renewable waste)	205	523	652	760	1,009	1,251
Hydro	3,672	4,458	4,832	5,207	5,822	6,431
Wind	521	1,254	1,608	1,962	2,552	3,232
<i>of which wind offshore</i>	19	69	123	189	346	521
PV	97	408	519	630	832	1,096
Geothermal	69	111	148	185	283	419
Solar thermal power plants	5	34	60	85	173	303
Ocean energy	0	3	6	10	41	76
<b>Combined heat and power plants</b>	<b>3,478</b>	<b>3,854</b>	<b>3,983</b>	<b>4,088</b>	<b>4,240</b>	<b>4,359</b>
Hard coal (& non-renewable waste)	1,670	1,873	1,929	1,966	1,958	1,891
Lignite	193	187	185	182	175	171
Gas	1,351	1,510	1,577	1,650	1,785	1,941
<i>of which from H<sub>2</sub></i>	0	0	0	0	0	0
Oil	88	63	50	36	26	23
Biomass (& renewable waste)	175	218	237	259	290	326
Geothermal	2	2	3	3	4	6
Hydrogen	0	1	1	1	1	1
<b>CHP by producer</b>						
Main activity producers	1,576	1,632	1,633	1,631	1,628	1,641
Autoproducers	1,903	2,222	2,349	2,457	2,612	2,717
<b>Total generation</b>	<b>22,604</b>	<b>28,492</b>	<b>32,374</b>	<b>36,256</b>	<b>44,007</b>	<b>50,110</b>
Fossil	15,409	18,266	20,865	23,464	29,104	32,945
Hard coal (& non-renewable waste)	7,148	9,189	10,631	12,123	15,182	16,966
Lignite	1,911	2,085	2,229	2,325	2,556	2,787
Gas	5,226	6,124	7,242	8,360	10,806	12,700
Oil	978	710	582	454	327	236
Diesel	147	158	180	202	234	256
Nuclear	2,450	3,215	3,443	3,670	3,856	4,054
Hydrogen	0	1	1	1	1	1
<i>of which renewable H<sub>2</sub></i>	0	0	0	0	0	0
<b>Renewables (w/o renewable hydrogen)</b>	<b>4,744</b>	<b>7,010</b>	<b>8,066</b>	<b>9,121</b>	<b>11,046</b>	<b>13,111</b>
Hydro	3,672	4,458	4,832	5,207	5,822	6,431
Wind	521	1,254	1,608	1,962	2,552	3,232
PV	97	408	519	630	832	1,096
Biomass (& renewable waste)	379	740	890	1,039	1,299	1,577
Geothermal	70	113	151	188	287	425
Solar thermal power plants	5	34	60	85	173	303
Ocean energy	0	3	6	10	41	76
Distribution losses	1,839	2,371	2,751	3,130	3,922	4,615
Own consumption electricity	1,910	2,161	2,328	2,495	2,835	2,878
Electricity for hydrogen production	0	3	3	4	4	4
Electricity for synfuel production	0	0	0	0	0	0
<b>Final energy consumption (electricity)</b>	<b>18,863</b>	<b>23,969</b>	<b>27,304</b>	<b>30,639</b>	<b>37,255</b>	<b>42,622</b>
Fluctuating RES (PV, Wind, Ocean)	618	1,665	2,133	2,602	3,425	4,374
Share of fluctuating RES	3%	6%	7%	7%	8%	9%
<b>RES share</b>	<b>21%</b>	<b>25%</b>	<b>25%</b>	<b>25%</b>	<b>25%</b>	<b>26%</b>

Table 13.1.2 Global: Final energy consumption in transport PJ/a

	2012	2020	2025	2030	2040	2050
<b>Road</b>	<b>78,688</b>	<b>89,912</b>	<b>98,701</b>	<b>107,510</b>	<b>120,944</b>	<b>130,313</b>
Fossil fuels	74,800	84,096	91,476	98,864	108,641	114,616
Biofuels	2,486	3,622	4,487	5,352	7,224	7,982
Synfuels	0	0	0	0	0	0
Natural gas	1,394	2,095	2,472	2,850	4,319	6,218
Hydrogen	0	0	0	0	0	0
Electricity	9	99	267	444	939	1,497
<b>Rail</b>	<b>2,766</b>	<b>3,134</b>	<b>3,335</b>	<b>3,517</b>	<b>3,887</b>	<b>4,260</b>
Fossil fuels	1,701	1,839	1,952	2,054	2,256	2,452
Biofuels	0	0	0	0	0	0
Synfuels	0	0	0	0	0	0
Electricity	1,065	1,294	1,383	1,463	1,631	1,808
<b>Navigation</b>	<b>2,173</b>	<b>2,506</b>	<b>2,707</b>	<b>2,963</b>	<b>3,269</b>	<b>3,470</b>
Fossil fuels	2,173	2,506	2,707	2,963	3,269	3,470
Biofuels	0	0	0	0	0	0
Synfuels	0	0	0	0	0	0
<b>Aviation</b>	<b>4,120</b>	<b>5,026</b>	<b>5,512</b>	<b>5,943</b>	<b>6,730</b>	<b>7,573</b>
Fossil fuels	4,120	5,026	5,512	5,943	6,730	7,573
Biofuels	0	0	0	0	0	0
Synfuels	0	0	0	0	0	0
<b>Total (incl. pipelines)</b>	<b>90,119</b>	<b>103,044</b>	<b>112,778</b>	<b>122,511</b>	<b>137,518</b>	<b>148,418</b>
Fossil fuels	82,794	93,468	101,647	109,825	120,716	128,112
Biofuels (incl. biogas)	2,486	3,622	4,487	5,352	7,224	7,982
Synfuels	0	0	0	0	0	0
Natural gas	3,765	4,561	4,994	5,427	7,008	9,020
Hydrogen	0	0	0	0	0	0
Electricity	1,074	1,393	1,650	1,907	2,570	3,304
<b>Total RES</b>	<b>2,711</b>	<b>3,964</b>	<b>4,898</b>	<b>5,832</b>	<b>7,869</b>	<b>8,846</b>
<b>RES share</b>	<b>3%</b>	<b>4%</b>	<b>4%</b>	<b>5%</b>	<b>6%</b>	<b>6%</b>

Table 13.1.3 Global: Heat supply PJ/a

	2012	2020	2025	2030	2040	2050
<b>District heating plants</b>	<b>8,275</b>	<b>9,035</b>	<b>9,538</b>	<b>10,053</b>	<b>10,456</b>	<b>10,732</b>
Fossil fuels	8,030	8,713	9,173	9,638	9,945	10,139
Biomass	239	309	348	393	477	548
Solar collectors	0	1	1	2	5	11
Geothermal	6	13	16	20	28	34
<b>Heat from CHP<sup>1</sup></b>	<b>10,083</b>	<b>11,280</b>	<b>11,876</b>	<b>12,498</b>	<b>13,876</b>	<b>16,079</b>
Fossil fuels	9,566	10,557	11,030	11,502	12,519	13,893
Biomass	507	704	823	969	1,320	2,139
Geothermal	10	15	19	23	31	40
Hydrogen	0	4	5	5	6	6
<b>Direct heating</b>	<b>129,571</b>	<b>149,371</b>	<b>159,100</b>	<b>169,071</b>	<b>188,257</b>	<b>205,512</b>
Fossil fuels	91,517	107,600	115,232	123,061	137,389	149,826
Biomass	26,739	28,805	29,945	31,105	33,793	36,299
Solar collectors	803	1,385	1,745	2,105	2,840	3,830
Geothermal	0	0	0	0	0	0
Heat pumps <sup>2</sup>	468	661	775	886	1,217	1,646
Electric direct heating	10,224	10,921	11,404	11,914	13,018	13,911
Hydrogen	0	0	0	0	0	0
<b>Total heat supply<sup>3</sup></b>	<b>148,109</b>	<b>169,687</b>	<b>180,515</b>	<b>191,622</b>	<b>212,588</b>	<b>232,322</b>
Fossil fuels	109,112	126,869	135,434	144,200	159,853	173,858
Biomass	27,486	29,818	31,115	32,467	35,590	38,986
Solar collectors	804	1,386	1,746	2,107	2,845	3,841
Geothermal	16	28	35	43	59	74
Heat pumps <sup>2</sup>	468	661	775	886	1,217	1,646
Electric direct heating	10,224	10,921	11,404	11,914	13,018	13,911
Hydrogen	0	4	5	5	6	6
<b>RES share (including RES electricity)</b>	<b>21%</b>	<b>20%</b>	<b>20%</b>	<b>20%</b>	<b>20%</b>	<b>21%</b>

<sup>1</sup> public CHP and CHP autoproduction / <sup>2</sup> heat from ambient energy and electricity use / <sup>3</sup> incl. process heat, cooking

Table 13.1.4: Global: Installed capacity GW

	2012	2020	2025	2030	2040	2050
<b>Total generation</b>	<b>5,680</b>	<b>7,343</b>	<b>8,237</b>	<b>9,130</b>	<b>10,747</b>	<b>12,033</b>
<b>Fossil</b>	<b>3,712</b>	<b>4,500</b>	<b>5,016</b>	<b>5,532</b>	<b>6,534</b>	<b>7,134</b>
Hard coal (& non-renewable waste)	1,407	1,820	2,092	2,373	2,888	3,091
Lignite	373	387	408	422	453	484
Gas (w/o H <sub>2</sub> )	1,499	1,918	2,178	2,439	2,930	3,341
Oil	378	308	264	216	161	112
Diesel	55	66	73	83	102	105
Nuclear	393	447	471	496	517	544
Hydrogen (fuel cells, gas power plants, gas CHP)	0	0	0	0	0	0
<b>Renewables</b>	<b>1,575</b>	<b>2,396</b>	<b>2,749</b>	<b>3,101</b>	<b>3,696</b>	<b>4,355</b>
Hydro	1,099	1,331	1,438	1,544	1,715	1,876
Wind	277	554	681	807	998	1,217
<i>of which wind offshore</i>	5	20	36	55	88	145
Biomass (& renewable waste)	97	332	413	494	635	803
Geothermal	11	17	22	28	42	62
Solar thermal power plants	3	11	19	26	49	74
Ocean energy	0	1	2	4	15	28
Fluctuating RES (PV, Wind, Ocean)	375	887	1,096	1,305	1,647	2,048
Share of fluctuating RES	7%	12%	13%	14%	15%	17%
<b>RES share</b>	<b>28%</b>	<b>33%</b>	<b>33%</b>	<b>34%</b>	<b>34%</b>	<b>36%</b>

Table 13.1.5: Global: Final energy demand PJ/a

	2012	2020	2025	2030	2040	2050
<b>Total (incl. non-energy use)</b>	<b>360,650</b>	<b>418,349</b>	<b>451,812</b>	<b>485,226</b>	<b>541,973</b>	<b>587,701</b>
<b>Total energy use</b>	<b>326,859</b>	<b>379,586</b>	<b>410,576</b>	<b>441,590</b>	<b>495,388</b>	<b>538,502</b>
<b>Transport</b>	<b>90,119</b>	<b>103,044</b>	<b>112,778</b>	<b>122,511</b>	<b>137,518</b>	<b>148,418</b>
Oil products	82,794	93,468	101,647	109,825	120,716	128,112
Natural gas	3,765	4,561	4,994	5,427	7,008	9,020
Biofuels	2,486	3,622	4,487	5,352	7,224	7,982
Synfuels	0	0	0	0	0	0
Electricity	1,074	1,393	1,650	1,907	2,570	3,304
RES electricity	2,275	343	411	480	645	865
Hydrogen	0	0	0	0	0	0
<b>RES share Transport</b>	<b>3%</b>	<b>4%</b>	<b>4%</b>	<b>5%</b>	<b>6%</b>	<b>6%</b>
<b>Industry</b>	<b>106,313</b>	<b>129,641</b>	<b>140,466</b>	<b>151,290</b>	<b>170,465</b>	<b>186,496</b>
Electricity	28,747					

**Table 13.1.8 Global: Electricity generation TWh/a**

	2012	2020	2025	2030	2040	2050
<b>Power plants</b>	<b>19,125</b>	<b>23,246</b>	<b>25,397</b>	<b>28,497</b>	<b>37,019</b>	<b>43,831</b>
Hard coal (& non-renewable waste)	5,477	6,330	5,830	4,745	2,357	468
Lignite	1,718	1,419	842	338	99	0
Gas	3,876	4,912	4,972	4,807	3,550	1,288
<i>of which from H<sub>2</sub></i>	0	0	0	0	28	69
Oil	889	575	404	166	33	9
Diesel	147	111	73	51	15	5
Nuclear	2,450	1,872	1,345	559	182	0
Biomass (& renewable waste)	205	510	555	590	606	620
Hydro	3,672	4,349	4,513	4,613	4,773	4,937
Wind	521	1,932	3,848	6,278	11,291	14,938
<i>of which wind offshore</i>	97	942	2,123	3,844	7,054	9,914
Geothermal	69	166	365	664	1,385	2,032
Solar thermal power plants	5	97	428	1,601	4,844	8,138
Ocean energy	1	31	101	251	831	1,482
<b>Combined heat and power plants</b>	<b>3,478</b>	<b>4,046</b>	<b>4,620</b>	<b>5,134</b>	<b>5,818</b>	<b>6,021</b>
Hard coal (& non-renewable waste)	1,670	1,773	1,615	1,328	562	126
Lignite	193	155	82	22	0	0
Gas	1,351	1,602	1,907	2,156	2,270	1,921
<i>of which from H<sub>2</sub></i>	0	0	0	2	56	281
Oil	88	58	25	8	3	1
Biomass (& renewable waste)	175	427	876	1,335	2,043	2,419
Geothermal	2	24	97	252	813	1,253
Hydrogen	0	7	16	32	126	300
<b>CHP by producer</b>						
Main activity producers	1,576	1,738	1,956	2,171	2,385	2,327
Autoproducers	1,903	2,308	2,663	2,963	3,433	3,694
<b>Total generation</b>	<b>22,604</b>	<b>27,292</b>	<b>30,016</b>	<b>33,631</b>	<b>42,837</b>	<b>49,852</b>
Fossil	15,409	18,936	15,752	13,619	8,805	3,469
Hard coal (& non-renewable waste)	7,148	8,104	7,446	6,074	2,919	594
Lignite	1,911	1,574	925	360	99	0
Gas	5,226	6,514	6,879	6,960	5,736	2,859
Oil	978	633	429	174	36	11
Diesel	147	111	73	51	15	5
Nuclear	2,450	1,872	1,345	559	182	0
Hydrogen	0	7	16	34	211	650
<i>of which renewable H<sub>2</sub></i>	0	2	7	20	166	604
Renewables (w/o renewable hydrogen)	4,744	8,478	12,904	19,419	33,640	45,733
Hydro	3,672	4,349	4,513	4,613	4,773	4,937
Wind	521	1,932	3,848	6,278	11,291	14,938
PV	97	942	2,123	3,844	7,054	9,914
Biomass (& renewable waste)	379	937	1,430	1,915	2,649	3,039
Geothermal	70	190	462	916	2,198	3,286
Solar thermal power plants	5	97	428	1,601	4,844	8,138
Ocean energy	1	31	101	251	831	1,482
Distribution losses	1,839	2,246	2,430	2,622	2,965	3,211
Own consumption electricity	1,910	2,050	2,098	2,058	1,826	1,315
Electricity for hydrogen production	0	36	245	983	4,237	8,330
Electricity for synfuel production	0	0	0	0	0	0
<b>Final energy consumption (electricity)</b>	<b>18,863</b>	<b>22,980</b>	<b>25,268</b>	<b>27,973</b>	<b>33,816</b>	<b>37,004</b>
Fluctuating RES (PV, Wind, Ocean)	618	2,904	6,071	10,373	19,176	26,334
Share of fluctuating RES	3%	11%	20%	31%	45%	53%
<b>RES share</b>	<b>21%</b>	<b>31%</b>	<b>43%</b>	<b>58%</b>	<b>79%</b>	<b>93%</b>

**Table 13.1.9 Global: Final energy consumption in transport PJ/a**

	2012	2020	2025	2030	2040	2050
<b>Road</b>	<b>78,688</b>	<b>83,781</b>	<b>82,443</b>	<b>79,473</b>	<b>67,361</b>	<b>57,356</b>
Fossil fuels	74,800	77,617	72,348	62,387	32,730	12,138
Biofuels	2,486	3,759	4,945	6,126	6,588	5,829
Synfuels	0	0	0	0	0	0
Natural gas	1,394	1,981	2,498	2,864	3,044	2,724
Hydrogen	0	18	367	1,930	8,190	13,521
Electricity	9	406	2,284	6,106	16,810	23,144
<b>Rail</b>	<b>2,766</b>	<b>3,110</b>	<b>3,231</b>	<b>3,338</b>	<b>3,631</b>	<b>3,751</b>
Fossil fuels	1,701	1,662	1,461	1,142	697	274
Biofuels	0	67	129	252	267	164
Synfuels	0	0	0	0	0	0
Electricity	1,065	1,381	1,640	1,945	2,667	3,314
<b>Navigation</b>	<b>2,173</b>	<b>2,492</b>	<b>2,615</b>	<b>2,728</b>	<b>2,849</b>	<b>2,860</b>
Fossil fuels	2,173	2,442	2,485	2,447	2,151	1,589
Biofuels	0	49	130	281	698	1,271
Synfuels	0	0	0	0	0	0
<b>Aviation</b>	<b>4,120</b>	<b>4,683</b>	<b>4,767</b>	<b>4,712</b>	<b>4,667</b>	<b>5,004</b>
Fossil fuels	4,120	4,678	4,621	4,335	3,638	2,946
Biofuels	0	4	146	377	1,030	2,058
Synfuels	0	0	0	0	0	0
<b>Total (incl. pipelines)</b>	<b>90,119</b>	<b>96,169</b>	<b>94,941</b>	<b>91,918</b>	<b>79,738</b>	<b>69,735</b>
Fossil fuels	82,794	86,400	80,915	70,311	39,216	16,947
Biofuels (incl. biogas)	2,486	3,880	5,351	7,035	8,583	9,322
Synfuels	0	0	0	0	0	0
Natural gas	3,765	4,074	4,352	4,464	4,043	2,960
Hydrogen	0	18	367	1,930	8,190	13,521
Electricity	1,074	1,797	3,956	8,117	19,706	26,985
<b>Total RES</b>	<b>2,711</b>	<b>4,444</b>	<b>7,210</b>	<b>12,877</b>	<b>30,598</b>	<b>46,972</b>
<b>RES share</b>	<b>3%</b>	<b>5%</b>	<b>8%</b>	<b>14%</b>	<b>38%</b>	<b>67%</b>

**Table 13.1.10 Global: Heat supply PJ/a**

	2012	2020	2025	2030	2040	2050
<b>District heating plants</b>	<b>8,275</b>	<b>8,580</b>	<b>9,343</b>	<b>9,658</b>	<b>10,355</b>	<b>9,738</b>
Fossil fuels	8,030	7,855	7,008	5,946	2,466	430
Biomass	239	622	1,311	1,852	2,768	2,384
Solar collectors	0	56	686	1,170	2,963	3,917
Geothermal	6	47	338	689	2,158	3,006
<b>Heat from CHP<sup>1</sup></b>	<b>10,083</b>	<b>12,720</b>	<b>15,517</b>	<b>18,605</b>	<b>25,629</b>	<b>31,685</b>
Fossil fuels	9,566	10,950	11,165	10,821	8,729	5,871
Biomass	507	1,537	3,437	5,485	9,132	12,459
Geothermal	10	187	799	2,067	6,703	10,328
Hydrogen	0	46	116	232	1,064	3,025
<b>Direct heating</b>	<b>129,751</b>	<b>141,519</b>	<b>140,142</b>	<b>137,770</b>	<b>127,812</b>	<b>115,170</b>
Fossil fuels	91,517	95,693	85,672	72,665	40,425	13,432
Biomass	26,739	29,247	30,159	29,281	26,603	23,718
Solar collectors	803	2,620	6,296	11,814	22,742	27,461
Geothermal	0	421	810	1,329	2,462	3,389
Heat pumps <sup>2</sup>	468	1,477	3,249	6,332	13,289	18,041
Electric direct heating	10,224	12,062	13,909	16,216	21,494	26,134
Hydrogen	0	0	47	133	797	2,995
<b>Total heat supply<sup>3</sup></b>	<b>148,109</b>	<b>162,819</b>	<b>165,002</b>	<b>166,032</b>	<b>163,796</b>	<b>156,593</b>
Fossil fuels	109,112	114,499	103,844	89,431	51,620	19,734
Biomass	27,486	31,406	34,907	36,619	38,504	38,562
Solar collectors	804	2,675	6,982	12,984	25,704	31,378
Geothermal	16	655	1,948	4,085	11,323	16,723
Heat pumps <sup>2</sup>	468	1,477	3,249	6,332	13,289	18,041
Electric direct heating	10,224	12,062	13,909	16,216	21,494	26,134
Hydrogen	0	46	163	366	1,862	6,021
<b>RES share (including RES electricity)</b>	<b>21%</b>	<b>25%</b>	<b>33%</b>	<b>42%</b>	<b>66%</b>	<b>86%</b>

<sup>1</sup> public CHP and CHP autoproduction / <sup>2</sup> heat from ambient energy and electricity use / <sup>3</sup> incl. process heat, cooking

**Table 13.1.10: Global: Installed capacity GW**

	2012	2020	2025	2030	2040	2050
<b>Total generation</b>	<b>5,680</b>	<b>7,492</b>	<b>9,148</b>	<b>11,521</b>	<b>16,112</b>	<b>19,469</b>
<b>Fossil</b>	<b>3,712</b>	<b>4,038</b>	<b>3,902</b>	<b>3,662</b>	<b>3,089</b>	<b>2,140</b>
Hard coal (& non-renewable waste)	1,407	1,612	1,474	1,305	743	264
Lignite	373	292	171	69	21	0
Gas (w/o H <sub>2</sub> )	1,499	1,863	2,018	2,164	2,285	1,861
Oil	378	284	203	96	28	5
Diesel	55	47	35	28	12	5
Nuclear	393	290	184	76	25	0
Hydrogen (fuel cells, gas power plants, gas CHP)	0	2	4	9	64	250
<b>Renewables</b>	<b>1,575</b>	<b>3,132</b>	<b>5,058</b>	<b>7,774</b>	<b>12,934</b>	<b>17,079</b>
Hydro	1,099	1,316	1,365	1,397	1,445	1,503
Wind	277	820	1,572	2,510	4,316	5,575
<i>of which wind offshore</i>	5	37	142	326	914	1,131
PV	97	732	1,603	2,839	4,988	6,745
Biomass (& renewable waste)	87	194	284	392	558	746
Geothermal	11	28	69	137	325	485
Solar thermal power plants	3	31	126	405	984	1,473
Ocean energy	0	11	37	95	318	552
Fluctuating RES (PV, Wind, Ocean)	375	1,563	3,214	5,444	9,622	12,871
Share of fluctuating RES	7%	21%	35%	47%	60%	66%
<b>RES share</b>	<b>28%</b>	<b>42%</b>	<b>55%</b>	<b>67%</b>	<b>80%</b>	<b>88%</b>

**Table 13.1.12: Global: Final energy demand PJ/a**

	2012	2020	2025	2030	2040	2050
<b>Total (incl. non-energy use)</b>	<b>360,850</b>	<b>392,643</b>	<b>391,235</b>	<b>384,295</b>	<b>355,240</b>	<b>323,128</b>
<b>Total energy use</b>	<b>326,859</b>	<b>356,213</b>	<b>354,466</b>	<b>347,228</b>	<b>319,112</b>	<b>288,506</b>
<b>Transport</b>	<b>90,119</b>	<b>96,169</b>	<b>94,941</b>	<b>91,918</b>	<b>79,738</b>	<b>69,735</b>
Oil products	82,794	86,400	80,915	70,311	39,216	16,947
Natural gas	3,765	4,074	4,352	4,464	4,043	2,960
Biofuels	2,486	3,880	5,351	7,035	8,583	9,322
Synfuels	0	0	0	0	0	0
Electricity	1,074	1,797	3,956	8,117	19,706	26,985
RES electricity	225	558	1,702	4,692	15,552	25,083

# GLOBAL: ADVANCED ENERGY [R]EVOLUTION SCENARIO

**Table 13.1.15 Global: Electricity generation TWh/a**

	2012	2020	2025	2030	2040	2050
<b>Power plants</b>	<b>19,125</b>	<b>23,540</b>	<b>26,677</b>	<b>31,733</b>	<b>46,121</b>	<b>61,524</b>
Hard coal (& non-renewable waste)	5,477	6,182	5,445	4,016	992	0
Lignite	1,718	1,419	842	338	99	0
Gas	3,876	4,872	4,920	4,719	3,185	1,358
of which from H <sub>2</sub>	0	0	21	53	381	1,358
Oil	889	585	401	153	29	0
Diesel	147	111	76	54	16	0
Nuclear	2,450	1,872	1,345	559	182	0
Biomass (& renewable waste)	205	552	630	658	683	701
Hydro	3,672	4,349	4,519	4,621	4,779	4,966
Wind	521	2,158	4,645	7,737	15,480	21,673
of which wind offshore	97	180	682	1,623	4,425	6,330
PV	97	1,090	2,659	5,067	9,442	13,613
Geothermal	69	186	460	897	2,106	3,167
Solar thermal power plants	5	131	608	2,552	7,988	14,035
Ocean energy	1	32	128	363	1,141	2,010
<b>Combined heat and power plants</b>	<b>3,478</b>	<b>4,046</b>	<b>4,620</b>	<b>5,134</b>	<b>5,818</b>	<b>6,011</b>
Hard coal (& non-renewable waste)	1,670	1,773	1,615	1,328	557	0
Lignite	193	155	82	22	0	0
Gas	1,351	1,602	1,907	2,155	2,251	1,728
of which from H <sub>2</sub>	0	0	10	38	308	1,728
Oil	88	58	25	8	3	0
Biomass (& renewable waste)	175	427	876	1,335	2,051	2,492
Geothermal	2	24	97	252	817	1,380
Hydrogen	0	7	16	33	138	411
<b>CHP by producer</b>						
Main activity producers	1,576	1,738	1,956	2,171	2,385	2,327
Autoproducers	1,903	2,308	2,663	2,963	3,433	3,684
<b>Total generation</b>	<b>22,604</b>	<b>27,586</b>	<b>31,297</b>	<b>36,867</b>	<b>51,939</b>	<b>67,535</b>
Fossil	15,409	16,757	15,284	12,703	6,443	0
Hard coal (& non-renewable waste)	7,148	7,955	7,061	5,344	1,549	0
Lignite	1,911	1,574	925	360	99	0
Gas	5,226	6,474	6,796	6,783	4,746	0
of which from H <sub>2</sub>	0	0	0	0	0	0
Oil	978	643	426	161	32	0
Diesel	147	111	76	54	16	0
Nuclear	2,450	1,872	1,345	559	182	0
Hydrogen	0	7	48	123	828	3,497
of which renewable H <sub>2</sub>	0	2	22	79	721	3,497
<b>Renewables (w/o renewable hydrogen)</b>	<b>4,744</b>	<b>8,950</b>	<b>14,621</b>	<b>23,482</b>	<b>44,487</b>	<b>64,037</b>
Hydro	3,672	4,349	4,519	4,621	4,779	4,966
Wind	521	2,158	4,645	7,737	15,480	21,673
PV	97	1,090	2,659	5,067	9,442	13,613
Biomass (& renewable waste)	379	979	1,505	1,993	2,734	3,193
Geothermal	70	210	558	1,149	2,923	4,547
Solar thermal power plants	5	131	608	2,552	7,988	14,035
Ocean energy	1	32	128	363	1,141	2,010
Distribution losses	1,839	2,246	2,430	2,622	3,069	3,318
Own consumption electricity	1,910	2,050	2,098	2,058	1,776	1,230
Electricity for hydrogen production	0	98	812	2,176	8,403	19,317
Electricity for synfuel production	0	51	70	328	1,851	3,514
<b>Final energy consumption (electricity)</b>	<b>18,863</b>	<b>23,161</b>	<b>25,912</b>	<b>29,689</b>	<b>36,847</b>	<b>40,163</b>
Fluctuating RES (PV, Wind, Ocean)	618	3,281	7,432	13,167	26,063	37,296
Share of fluctuating RES	3%	12%	24%	36%	50%	55%
<b>RES share</b>	<b>21%</b>	<b>32%</b>	<b>47%</b>	<b>64%</b>	<b>87%</b>	<b>100%</b>

**Table 13.1.16 Global: Final energy consumption in transport PJ/a**

	2012	2020	2025	2030	2040	2050
<b>Road</b>	<b>78,688</b>	<b>82,653</b>	<b>78,457</b>	<b>71,706</b>	<b>51,475</b>	<b>38,750</b>
Fossil fuels	74,800	76,151	66,806	52,751	16,057	0
Biofuels	2,486	3,659	4,742	5,190	5,451	3,996
Synfuels	0	67	91	388	1,988	2,737
Natural gas	1,394	1,922	2,080	1,788	645	0
Hydrogen	0	169	1,305	3,773	11,228	14,039
Electricity	9	751	3,524	8,204	18,095	20,715
<b>Rail</b>	<b>2,766</b>	<b>3,278</b>	<b>3,922</b>	<b>4,718</b>	<b>6,774</b>	<b>8,356</b>
Fossil fuels	1,701	1,557	1,256	881	340	0
Biofuels	0	47	103	152	175	130
Synfuels	0	1	2	11	64	89
Electricity	1,065	1,673	2,561	3,674	6,196	8,138
<b>Navigation</b>	<b>2,173</b>	<b>2,492</b>	<b>2,615</b>	<b>2,698</b>	<b>2,739</b>	<b>2,700</b>
Fossil fuels	2,173	2,451	2,554	2,323	1,703	0
Biofuels	0	40	60	349	759	1,603
Synfuels	0	1	1	26	277	1,098
<b>Aviation</b>	<b>4,120</b>	<b>4,636</b>	<b>4,635</b>	<b>4,423</b>	<b>3,885</b>	<b>3,602</b>
Fossil fuels	4,120	4,615	4,548	3,826	2,452	0
Biofuels	0	21	85	555	1,050	2,138
Synfuels	0	0	2	42	383	1,464
<b>Total (incl. pipelines)</b>	<b>90,119</b>	<b>95,181</b>	<b>91,510</b>	<b>85,457</b>	<b>67,446</b>	<b>56,534</b>
Fossil fuels	82,794	84,774	75,165	59,782	20,552	0
Biofuels (incl. biogas)	2,486	3,767	4,990	6,247	7,436	7,866
Synfuels	0	69	95	467	2,711	5,387
Natural gas	3,765	3,964	3,797	3,161	1,142	0
Hydrogen	0	169	1,305	3,773	11,228	14,039
Electricity	1,074	2,438	6,158	12,027	24,778	29,242
<b>Total RES</b>	<b>2,711</b>	<b>4,635</b>	<b>8,526</b>	<b>16,643</b>	<b>41,135</b>	<b>56,533</b>
<b>RES share</b>	<b>3%</b>	<b>5%</b>	<b>9%</b>	<b>19%</b>	<b>61%</b>	<b>100%</b>

**Table 13.1.17 Global: Heat supply PJ/a**

	2012	2020	2025	2030	2040	2050
<b>District heating plants</b>	<b>8,275</b>	<b>8,571</b>	<b>9,339</b>	<b>9,650</b>	<b>10,330</b>	<b>9,287</b>
Fossil fuels	8,030	7,847	7,008	5,946	2,463	0
Biomass	239	621	1,308	1,847	2,758	2,330
Solar collectors	0	56	685	1,168	2,954	3,823
Geothermal	0	47	338	689	2,155	3,134
<b>Heat from CHP<sup>1</sup></b>	<b>10,083</b>	<b>12,729</b>	<b>15,526</b>	<b>18,624</b>	<b>25,701</b>	<b>32,842</b>
Fossil fuels	9,566	10,957	11,136	10,712	7,849	0
Biomass	507	1,537	3,444	5,497	9,177	12,859
Geothermal	10	188	799	2,068	6,735	11,407
Hydrogen	0	46	147	348	1,939	8,576
<b>Direct heating</b>	<b>129,571</b>	<b>141,520</b>	<b>140,137</b>	<b>137,759</b>	<b>127,765</b>	<b>114,433</b>
Fossil fuels	91,517	95,694	85,379	71,879	35,740	10,150
Biomass	26,739	29,246	30,158	29,279	26,593	24,198
Solar collectors	803	2,620	6,309	11,826	22,947	28,624
Geothermal	0	421	810	1,329	2,505	3,579
Heat pumps <sup>2</sup>	468	1,477	3,249	6,332	13,623	18,707
Electric direct heating	10,224	12,062	14,003	16,477	22,674	29,176
Hydrogen	0	0	228	638	3,683	0
<b>Total heat supply<sup>3</sup></b>	<b>148,109</b>	<b>162,819</b>	<b>165,002</b>	<b>166,033</b>	<b>163,795</b>	<b>156,563</b>
Fossil fuels	109,112	114,498	103,523	88,536	46,052	10,150
Biomass	27,486	31,404	34,909	36,623	38,527	39,386
Solar collectors	804	2,676	6,994	12,994	25,901	32,446
Geothermal	16	657	1,948	4,085	11,395	18,121
Heat pumps <sup>2</sup>	468	1,477	3,249	6,332	13,623	18,707
Electric direct heating	10,224	12,062	14,003	16,477	22,674	29,176
Hydrogen	0	0	375	986	5,622	8,576
<b>RES share (including RES electricity)</b>	<b>21%</b>	<b>25%</b>	<b>33%</b>	<b>43%</b>	<b>70%</b>	<b>94%</b>

<sup>1</sup> public CHP and CHP autoproduction / <sup>2</sup> heat from ambient energy and electricity use / <sup>3</sup> incl. process heat, cooking

**Table 13.1.18: Global: Installed capacity GW**

	2012	2020	2025	2030	2040	2050
<b>Total generation</b>	<b>5,680</b>	<b>7,645</b>	<b>9,873</b>	<b>13,146</b>	<b>19,951</b>	<b>25,835</b>
<b>Fossil</b>	<b>3,712</b>	<b>4,035</b>	<b>3,831</b>	<b>3,500</b>	<b>2,491</b>	<b>0</b>
Hard coal (& non-renewable waste)	1,407	1,586	1,399	1,136	377	0
Lignite	373	291	172	70	21	0
Gas (w/o H <sub>2</sub> )	1,499	1,821	2,021	2,172	2,054	0
Oil	378	289	202	93	24	0
Diesel	55	47	36	30	15	0
Nuclear	393	200	184	76	25	0
Hydrogen (fuel cells, gas power plants, gas CHP)	0	2	14	37	330	2,220
<b>Renewables</b>	<b>1,575</b>	<b>3,348</b>	<b>5,844</b>	<b>9,532</b>	<b>17,105</b>	<b>23,614</b>
Hydro	1,099	1,316	1,368	1,402	1,457	1,536
Wind	277	904	1,873	3,064	5,892	8,040
of which wind offshore	5	51	201	480	1,271	1,781
PV	97	844	2,000	3,725	6,678	9,285
Biomass (& renewable waste)	87	200	295	405	579	742
Geothermal	11	31	85	171	452	706
Solar thermal power plants	3	42	177	635	1,616	2,555
Ocean energy	0	11	46	131	432	738
Fluctuating RES (PV, Wind, Ocean)	375	1,760	3,919	6,919	13,001	18,074
Share of fluctuating RES	7%	23%	40%	53%	65%	70%
<b>RES share</b>	<b>28%</b>	<b>44%</b>	<b>59%</b>	<b>73%</b>	<b>86%</b>	<b>91%</b>

**Table 13.1.19: Global: Final energy demand PJ/a**

	2012	2020	2025	2030	2040	2050
<b>Total (incl. non-energy use)</b>	<b>360,650</b>	<b>391,662</b>	<b>387,812</b>	<b>379,271</b>	<b>346,573</b>	<b>313,575</b>
<b>Total energy use</b>	<b>326,859</b>	<b>355,232</b>	<b>351,043</b>	<b>342,204</b>	<b>310,445</b>	<b>278,953</b>
<b>Transport</b>	<b>90,119</b>	<b>95,181</b>	<b>91,510</b>	<b>85,457</b>	<b>67,446</b>	<b>56,534</b>
Oil products	82,794	84,774	75,165	59,782	20,552	0
Natural gas	3,765	3,964	3,797	3,161	1,142	0
Biofuels	2,486	3,767	4,990	6,247	7,436	7,866
Synfuels	0	69	95	467	2,711	5,387
Electricity						

Table 13.1.22: Global: Investments in electricity generation

REF	UNIT	2012-2020	2021-2030	2031-2040	2041-2050	2012-2050	UNIT	ANNUAL AVERAGE 2012-2050
Fossil (w/o CHP)	billion \$	1,673.6	2,205.0	2,725.4	2,866.8	9,470.9	billion \$/a	242.8
Nuclear	billion \$	678.6	740.5	654.9	731.1	2,805.1	billion \$/a	71.9
CHP (fossil + renewable)	billion \$	712.2	651.8	433.5	123.8	1,921.3	billion \$/a	49.3
Renewables (w/o CHP)	billion \$	2,417.8	2,274.4	2,863.0	2,775.8	10,331.0	billion \$/a	264.9
<b>Total</b>	<b>billion \$</b>	<b>5,482.3</b>	<b>5,871.7</b>	<b>6,676.8</b>	<b>6,497.6</b>	<b>24,528.3</b>	<b>billion \$/a</b>	<b>628.9</b>
Conventional (fossil & nuclear)	billion \$	2,996.6	3,512.9	3,753.8	3,680.7	13,944.1	billion \$/a	357.5
Renewables	billion \$	2,485.7	2,358.8	2,922.9	2,816.9	10,584.3	billion \$/a	271.4
Biomass	billion \$	209.1	229.3	281.1	265.3	984.8	billion \$/a	25.3
Hydro	billion \$	999.9	984.4	900.9	896.3	3,780.5	billion \$/a	96.9
Wind	billion \$	585.5	690.7	973.4	1,011.5	3,261.1	billion \$/a	83.6
PV	billion \$	516.5	253.5	454.5	281.4	1,505.9	billion \$/a	38.6
Geothermal	billion \$	113.4	111.4	132.0	157.5	514.2	billion \$/a	13.2
Solar thermal power plants	billion \$	56.2	76.9	139.9	174.3	447.5	billion \$/a	11.5
Ocean energy	billion \$	4.9	12.5	41.1	31.6	90.2	billion \$/a	2.3
<b>E[R]</b>								
Fossil (w/o CHP)	billion \$	1,248.5	544.4	819.7	858.0	3,470.6	billion \$/a	89.0
Nuclear	billion \$	197.6	0.6	0.8	0.0	198.9	billion \$/a	5.1
CHP (fossil + renewable)	billion \$	851.2	1,362.8	1,490.5	1,675.0	5,379.5	billion \$/a	137.9
Renewables (w/o CHP)	billion \$	3,808.8	9,872.1	12,385.8	13,170.0	39,236.7	billion \$/a	1,006.1
<b>Total</b>	<b>billion \$</b>	<b>6,106.1</b>	<b>11,779.9</b>	<b>14,696.7</b>	<b>15,703.0</b>	<b>48,285.8</b>	<b>billion \$/a</b>	<b>1,238.1</b>
Conventional (fossil & nuclear)	billion \$	2,072.6	1,066.4	1,147.0	1,019.4	5,305.3	billion \$/a	136.0
Renewables	billion \$	4,033.5	10,713.5	13,549.8	14,683.7	42,980.4	billion \$/a	1,102.1
Biomass	billion \$	341.0	659.3	747.5	1,136.2	2,884.0	billion \$/a	73.9
Hydro	billion \$	963.8	643.0	567.1	608.8	2,782.7	billion \$/a	71.4
Wind	billion \$	1,068.3	3,361.5	4,437.7	5,176.3	14,043.8	billion \$/a	360.1
PV	billion \$	1,212.8	2,812.9	2,914.4	3,045.8	9,986.0	billion \$/a	256.1
Geothermal	billion \$	214.5	898.8	1,299.3	1,280.3	3,692.9	billion \$/a	94.7
Solar thermal power plants	billion \$	168.7	1,921.2	2,796.6	2,818.1	7,704.7	billion \$/a	197.6
Ocean energy	billion \$	64.3	416.8	787.1	618.1	1,886.4	billion \$/a	48.4
<b>ADV E[R]</b>								
Fossil (w/o CHP)	billion \$	1,167.4	496.0	938.5	1,069.2	3,671.1	billion \$/a	94.1
Nuclear	billion \$	197.6	0.6	0.8	0.0	198.9	billion \$/a	5.1
CHP (fossil + renewable)	billion \$	851.9	1,359.0	1,467.1	1,619.6	5,297.6	billion \$/a	135.8
Renewables (w/o CHP)	billion \$	4,292.3	13,403.0	18,094.0	19,835.9	55,625.2	billion \$/a	1,426.3
<b>Total</b>	<b>billion \$</b>	<b>6,509.1</b>	<b>15,258.6</b>	<b>20,500.3</b>	<b>22,524.7</b>	<b>64,792.8</b>	<b>billion \$/a</b>	<b>1,661.4</b>
Conventional (fossil & nuclear)	billion \$	1,981.0	1,016.8	1,250.2	1,194.9	5,443.0	billion \$/a	139.6
Renewables	billion \$	4,528.1	14,241.8	19,250.1	21,329.9	59,349.8	billion \$/a	1,521.8
Biomass	billion \$	364.0	673.6	773.7	1,036.2	2,847.5	billion \$/a	73.0
Hydro	billion \$	963.8	657.3	588.7	668.8	2,878.7	billion \$/a	73.8
Wind	billion \$	1,243.5	4,341.0	6,518.9	7,549.4	19,652.8	billion \$/a	503.9
PV	billion \$	1,402.1	3,826.3	3,845.3	4,333.3	13,406.9	billion \$/a	343.8
Geothermal	billion \$	266.5	1,136.0	1,822.3	1,856.6	5,071.3	billion \$/a	130.0
Solar thermal power plants	billion \$	230.3	3,019.3	4,654.6	5,071.2	12,975.3	billion \$/a	332.7
Ocean energy	billion \$	67.9	588.3	1,046.7	814.4	2,517.3	billion \$/a	64.5

Table 13.1.23: Global: Investments in renewable heat generation

REF	UNIT	2012-2020	2021-2030	2031-2040	2041-2050	2012-2050	UNIT	ANNUAL AVERAGE 2012-2050
Heat pumps	billion \$	131.7	134.3	169.9	184.6	620.5	billion \$/a	15.9
Deep geothermal	billion \$	6.2	0.5	10.1	6.1	22.9	billion \$/a	0.6
Solar thermal	billion \$	119.2	145.2	216.1	251.4	731.8	billion \$/a	18.8
Biomass	billion \$	1,034.4	912.8	427.9	391.7	2,766.9	billion \$/a	70.9
<b>Total</b>	<b>billion \$</b>	<b>1,291.5</b>	<b>1,192.8</b>	<b>824.0</b>	<b>833.8</b>	<b>4,142.1</b>	<b>billion \$/a</b>	<b>106.2</b>
<b>E[R]</b>								
Heat pumps	billion \$	332.5	1,325.4	1,951.0	2,282.9	5,891.9	billion \$/a	151.1
Deep geothermal	billion \$	122.9	252.4	1,133.5	1,003.7	2,512.5	billion \$/a	64.4
Solar thermal	billion \$	401.2	1,778.8	2,258.7	1,749.4	6,188.1	billion \$/a	158.7
Biomass	billion \$	893.7	403.7	269.5	164.1	1,731.0	billion \$/a	44.4
<b>Total</b>	<b>billion \$</b>	<b>1,750.3</b>	<b>3,760.4</b>	<b>5,612.6</b>	<b>5,200.2</b>	<b>16,323.0</b>	<b>billion \$/a</b>	<b>418.5</b>
<b>ADV E[R]</b>								
Heat pumps	billion \$	332.5	1,325.4	2,040.8	2,393.0	6,091.7	billion \$/a	156.2
Deep geothermal	billion \$	123.0	252.4	1,139.7	1,123.1	2,638.2	billion \$/a	67.6
Solar thermal	billion \$	401.3	1,782.2	2,304.6	1,819.0	6,307.2	billion \$/a	161.7
Biomass	billion \$	893.6	403.5	268.6	130.3	1,695.9	billion \$/a	43.5
<b>Total</b>	<b>billion \$</b>	<b>1,750.3</b>	<b>3,763.5</b>	<b>5,753.7</b>	<b>5,465.4</b>	<b>16,733.0</b>	<b>billion \$/a</b>	<b>429.1</b>

Table 13.1.24: Global: Total employment in the energy sector MILLION JOBS

By fuel	REFERENCE SCENARIO						ADV E[R] SCENARIO	
	2015	2020	2025	2030	2020	2025	2030	
Coal	9.76	9.67	8.63	7.70	4.80	3.28	1.97	
Gas, oil & diesel	3.58	4.16	4.56	4.67	4.00	4.18	3.98	
Nuclear	0.73	0.86	0.83	0.74	0.52	0.52	0.51	
Renewable	14.62	15.41	15.59	14.84	26.91	38.68	41.56	
<b>Total jobs</b>	<b>28.69</b>	<b>30.11</b>	<b>29.62</b>	<b>27.95</b>	<b>36.24</b>	<b>46.65</b>	<b>48.01</b>	
<b>By sector</b>								
Construction and installation	4.86	5.09	4.60	3.95	8.32	14.59	15.56	
Manufacturing	2.38	2.44	2.23	1.91	5.49	8.87	9.58	
Operations and maintenance	3.23	3.94	4.30	4.27	4.82	6.96	9.00	
Fuel supply (domestic)	17.76	18.12	17.93	17.27	17.27	15.97	13.67	
Coal and gas export	0.47	0.52	0.54	0.57	0.34	0.26	0.20	
<b>Total jobs (million)</b>	<b>28.69</b>	<b>30.11</b>	<b>29.62</b>	<b>27.95</b>	<b>36.24</b>	<b>46.65</b>	<b>48.01</b>	
<b>By technology</b>								
Coal	9.76	9.67	8.63	7.70	4.80	3.28	1.97	
Gas, oil & diesel	3.58	4.16	4.56	4.67	4.00	4.18	3.98	
Nuclear	0.73	0.86	0.83	0.74	0.52	0.52	0.51	
Biomass	10.97	11.85	12.05	11.76	12.07	12.55	11.54	
Hydro	1.45	1.46	1.47	1.29	1.01	0.83	0.71	
Wind	0.70	0.72	0.76	0.65	4.22	6.91	8.18	
PV	1.01	0.87	0.84	0.66	6.69	11.04	10.32	
Geothermal power	0.03	0.03	0.03	0.03	0.18	0.30	0.39	
Solar thermal power	0.03	0.04	0.05	0.08	0.45	1.66	2.66	
Ocean	0.00	0.00	0.00	0.01	0.23	0.45	0.65	
Solar - heat	0.36	0.37	0.34	0.31	1.59	3.94	5.64	
Geothermal & heat pump	0.07	0.05	0.04	0.04	0.48	0.99	1.46	
<b>Total jobs (million)</b>	<b>28.7</b>	<b>30.1</b>	<b>29.6</b>	<b>28.0</b>	<b>36.2</b>	<b>46.7</b>	<b>48.0</b>	

# OECD NORTH AMERICA: REFERENCE SCENARIO

Table 13.2.1 OECD North America: Electricity generation <sup>TWh/a</sup>

	2012	2020	2025	2030	2040	2050
<b>Power plants</b>	<b>4,856</b>	<b>5,460</b>	<b>5,800</b>	<b>6,140</b>	<b>6,891</b>	<b>7,649</b>
Hard coal (& non-renewable waste)	765	908	909	967	1,069	1,132
Lignite	941	1,011	1,095	1,121	1,180	1,259
Gas	1,234	1,316	1,450	1,584	1,952	2,367
<i>of which from H/</i>						
Oil	75	45	36	26	16	8
Diesel	9	10	10	9	8	6
Nuclear	905	951	954	957	937	935
Biomass (& renewable waste)	42	89	109	129	165	202
Hydro	691	730	748	765	798	806
Wind	157	295	349	403	501	605
<i>of which wind offshore</i>						
Oil	9	6	11	17	42	74
PV	9	56	79	101	145	201
Geothermal	24	36	43	49	58	69
Solar thermal power plants	1	14	21	28	37	47
Ocean energy	0	0	1	2	5	12
<b>Combined heat and power plants</b>	<b>347</b>	<b>334</b>	<b>311</b>	<b>287</b>	<b>250</b>	<b>221</b>
Hard coal (& non-renewable waste)	42	39	32	26	19	8
Lignite	5	3	2	2	2	2
Gas	254	249	233	217	189	169
<i>of which from H/</i>						
Oil	12	7	6	5	2	1
Biomass (& renewable waste)	34	35	36	37	38	41
Geothermal	0	0	0	0	0	0
Hydrogen	0	0	0	0	0	0
<b>CHP by producer</b>						
Main activity producers	194	182	157	133	93	63
Autoproducers	153	153	154	155	157	159
<b>Total generation</b>	<b>5,203</b>	<b>5,794</b>	<b>6,111</b>	<b>6,428</b>	<b>7,141</b>	<b>7,871</b>
Fossil	3,340	3,588	3,773	3,957	4,457	4,952
Hard coal (& non-renewable waste)	810	947	941	993	1,108	1,139
Lignite	946	1,014	1,098	1,123	1,182	1,261
Gas	1,487	1,565	1,683	1,801	2,141	2,537
Oil	87	52	42	31	17	9
Diesel	9	10	10	9	8	6
Nuclear	905	951	954	957	937	935
Hydrogen	0	0	0	0	0	0
<i>of which renewable H/</i>						
Oil	9	6	11	17	42	74
PV	9	56	79	101	145	201
Biomass (& renewable waste)	76	124	145	166	204	243
Geothermal	24	36	43	49	58	69
Solar thermal power plants	1	14	21	28	37	47
Ocean energy	0	0	1	2	5	12
Distribution losses	358	406	433	459	519	582
Own consumption electricity	382	384	391	399	416	416
Electricity for hydrogen production	0	0	0	0	0	0
Electricity for synfuel production	0	0	0	0	0	0
<b>Final energy consumption (electricity)</b>	<b>4,459</b>	<b>5,001</b>	<b>5,284</b>	<b>5,567</b>	<b>6,204</b>	<b>6,870</b>
Fluctuating RES (PV, Wind, Ocean)	166	351	428	506	651	818
Share of fluctuating RES	3%	6%	7%	8%	9%	10%
<b>RES share (domestic generation)</b>	<b>18%</b>	<b>22%</b>	<b>23%</b>	<b>24%</b>	<b>24%</b>	<b>25%</b>

Table 13.2.2 OECD North America: Final energy consumption in transport <sup>PJ/a</sup>

	2012	2020	2025	2030	2040	2050
<b>Road</b>	<b>25,564</b>	<b>26,133</b>	<b>26,090</b>	<b>26,039</b>	<b>26,275</b>	<b>26,487</b>
Fossil fuels	24,388	24,509	24,065	23,615	22,425	21,421
Biofuels	1,139	1,499	1,793	2,086	2,857	3,154
Synfuels	0	0	0	0	0	0
Natural gas	32	105	193	281	848	1,631
Hydrogen	0	0	0	0	0	0
Electricity	5	19	38	58	144	280
<b>Rail</b>	<b>663</b>	<b>696</b>	<b>723</b>	<b>749</b>	<b>804</b>	<b>877</b>
Fossil fuels	624	658	682	705	757	827
Biofuels	0	0	0	0	0	0
Synfuels	0	0	0	0	0	0
Electricity	39	39	41	44	47	50
<b>Navigation</b>	<b>550</b>	<b>571</b>	<b>589</b>	<b>602</b>	<b>630</b>	<b>657</b>
Fossil fuels	550	571	589	602	630	657
Biofuels	0	0	0	0	0	0
Synfuels	0	0	0	0	0	0
<b>Aviation</b>	<b>2,161</b>	<b>2,253</b>	<b>2,307</b>	<b>2,372</b>	<b>2,529</b>	<b>2,717</b>
Fossil fuels	2,161	2,253	2,307	2,372	2,529	2,717
Biofuels	0	0	0	0	0	0
Synfuels	0	0	0	0	0	0
<b>Total (incl. pipelines)</b>	<b>29,748</b>	<b>30,504</b>	<b>30,579</b>	<b>30,654</b>	<b>31,170</b>	<b>31,712</b>
Fossil fuels	27,723	27,992	27,643	27,294	26,341	25,623
Biofuels (incl. biogas)	1,139	1,499	1,793	2,086	2,857	3,154
Synfuels	0	0	0	0	0	0
Natural gas	842	956	1,064	1,173	1,781	2,605
Hydrogen	0	0	0	0	0	0
Electricity	44	58	80	101	191	330
<b>Total RES</b>	<b>1,147</b>	<b>1,512</b>	<b>1,811</b>	<b>2,110</b>	<b>2,904</b>	<b>3,237</b>
<b>RES share</b>	<b>4%</b>	<b>5%</b>	<b>6%</b>	<b>7%</b>	<b>9%</b>	<b>10%</b>

Table 13.2.3 OECD North America: Heat supply <sup>PJ/a</sup>

	2012	2020	2025	2030	2040	2050
<b>District heating plants</b>	<b>0</b>	<b>48</b>	<b>61</b>	<b>72</b>	<b>82</b>	<b>96</b>
Fossil fuels	0	46	59	69	77	90
Biomass	0	2	2	4	5	7
Solar collectors	0	0	0	0	0	0
Geothermal	0	0	0	0	0	0
<b>Heat from CHP<sup>1</sup></b>	<b>867</b>	<b>865</b>	<b>839</b>	<b>820</b>	<b>830</b>	<b>969</b>
Fossil fuels	779	771	736	704	665	646
Biomass	88	94	103	117	165	323
Geothermal	0	0	0	0	0	0
Hydrogen	0	0	0	0	0	0
<b>Direct heating</b>	<b>19,082</b>	<b>20,914</b>	<b>21,471</b>	<b>22,031</b>	<b>23,247</b>	<b>24,607</b>
Fossil fuels	15,798	17,333	17,619	17,911	18,343	18,746
Biomass	1,697	1,920	2,069	2,217	2,736	3,328
Solar collectors	68	125	199	272	474	766
Geothermal	0	0	0	0	0	0
Heat pumps <sup>2</sup>	14	14	14	14	15	15
Electric direct heating	1,506	1,522	1,571	1,616	1,680	1,752
Hydrogen	0	0	0	0	0	0
<b>Total heat supply<sup>3</sup></b>	<b>19,949</b>	<b>21,827</b>	<b>22,371</b>	<b>22,924</b>	<b>24,159</b>	<b>25,672</b>
Fossil fuels	16,577	18,149	18,414	18,684	19,085	19,481
Biomass	1,784	2,016	2,174	2,338	2,905	3,658
Solar collectors	68	125	199	272	474	766
Geothermal	0	0	0	0	0	0
Heat pumps <sup>2</sup>	14	14	14	14	15	15
Electric direct heating	1,506	1,522	1,571	1,616	1,680	1,752
Hydrogen	0	0	0	0	0	0
<b>RES share (including RES electricity)</b>	<b>11%</b>	<b>11%</b>	<b>12%</b>	<b>13%</b>	<b>16%</b>	<b>19%</b>

<sup>1</sup> public CHP and CHP autoproduction / <sup>2</sup> heat from ambient energy and electricity use / <sup>3</sup> incl. process heat, cooking

Table 13.2.4: OECD North America: Installed capacity <sup>GW</sup>

	2012	2020	2025	2030	2040	2050
<b>Total generation</b>	<b>1,356</b>	<b>1,472</b>	<b>1,544</b>	<b>1,616</b>	<b>1,742</b>	<b>1,943</b>
<b>Fossil</b>	<b>932</b>	<b>959</b>	<b>986</b>	<b>1,013</b>	<b>1,075</b>	<b>1,197</b>
Hard coal (& non-renewable waste)	163	161	157	164	177	182
Lignite	188	171	183	185	189	201
Gas (w/o H/)	495	570	598	625	690	797
Oil	75	45	38	30	17	8
Diesel	11	12	11	10	12	9
Nuclear	124	123	123	123	120	120
Hydrogen (fuel cells, gas power plants, gas CHP)	0	0	0	0	0	0
<b>Renewables</b>	<b>300</b>	<b>391</b>	<b>435</b>	<b>479</b>	<b>547</b>	<b>626</b>
Hydro	204	208	213	217	214	214
Wind	67	109	127	144	175	207
<i>of which wind offshore</i>						
Oil	9	40	55	70	99	133
Biomass (& renewable waste)	16	24	28	31	37	45
Geothermal	4	6	7	8	10	14
Solar thermal power plants	1	5	7	9	11	14
Ocean energy	0	0	0	1	2	4
Fluctuating RES (PV, Wind, Ocean)	75	148	182	215	276	343
Share of fluctuating RES	6%	10%	12%	13%	16%	18%
<b>RES share (domestic generation)</b>	<b>22%</b>	<b>27%</b>	<b>28%</b>	<b>30%</b>	<b>31%</b>	<b>32%</b>

Table 13.2.5: OECD North America: Final energy demand <sup>PJ/a</sup>

	2012	2020	2025	2030	2040	2050
<b>Total (incl. non-energy use)</b>	<b>73,586</b>	<b>79,453</b>	<b>80,815</b>	<b>82,178</b>	<b>85,148</b>	<b>88,579</b>
<b>Total energy use</b>	<b>67,806</b>	<b>72,296</b>	<b>73,628</b>	<b>74,959</b>	<b>78,064</b>	<b>81,630</b>
<b>Transport</b>	<b>29,748</b>	<b>30,504</b>	<b>30,579</b>	<b>30,654</b>	<b>31,170</b>	<b>31,712</b>
Oil products	27,723	27,992	27,643	27,294	26,341	25,623
Natural gas	842	956	1,064	1,173	1,781	2,605
Biofuels	1,139	1,499	1,793	2,086	2,857	3,154
Synfuels	0	0	0	0	0	0
Electricity	44	58	80	101	191	330
RES electricity	8	12	18	24	47	83
Hydrogen	0	0	0	0	0	0
<b>RES share Transport</b>	<b>4%</b>	<b>5%</b>	<b>6%</b>	<b>7%</b>	<b>9%</b>	<b>10%</b>
<b>Industry</b>	<b>14,131</b>	<b>15,780</b>	<b>15,973</b>	<b>16,166</b>	<b>16,503</b>	<b>16,894</b>
Electricity	4,191	4,804	4,961	5,119	5,408	5,726
RES electricity	772	1,040	1,124	1,206	1,324	1,443
Public district heat	241	256	240	224	199	174
RES district heat	8	14	13	13	12	10
Hard coal & lignite	988	1,102	1,050	998	907	732
Oil products	1,406	1,417	1,372	1,328	1,263	1,188
Gas	5,943	6,555	6,574	6,593	6,572	6,626
Solar	0	8	12	16	22	29
Biomass	1,358	1,634	1,759	1,884	2,128	2,415
Geothermal	4	4	4	4	4	4
Hydrogen	0	0	0	0	0	0
<b>RES share Industry</b>	<b>15%</b>	<b>17%</b>	<b>18%</b>	<b>19%</b>	<b>21%</b>	<b>23%</b>
<b>Other Sectors</b>	<b>23,927</b>	<b>26,012</b>				



# OECD NORTH AMERICA: ENERGY [R]EVOLUTION SCENARIO

Table 13.2.8 OECD North America: Electricity generation TWh/a

	2012	2020	2025	2030	2040	2050
<b>Power plants</b>	<b>4,856</b>	<b>4,975</b>	<b>5,259</b>	<b>5,725</b>	<b>6,704</b>	<b>6,649</b>
Hard coal (& non-renewable waste)	768	477	278	210	85	0
Lignite	941	709	374	27	0	0
Gas	1,234	1,607	1,558	1,459	887	147
of which from H <sub>2</sub>	0	0	0	0	0	0
Oil	75	40	31	16	4	0
Diesel	9	7	5	3	1	0
Nuclear	905	508	374	53	0	0
Biomass (& renewable waste)	42	44	34	26	14	16
Hydro	691	741	765	776	782	782
of which wind offshore	157	559	1,095	1,527	2,153	2,306
PV	9	203	542	964	1,252	1,318
Geothermal	24	49	87	173	301	409
Solar thermal power plants	1	16	87	415	957	1,209
Ocean energy	0	17	29	77	269	460
<b>Combined heat and power plants</b>	<b>347</b>	<b>398</b>	<b>435</b>	<b>496</b>	<b>548</b>	<b>502</b>
Hard coal (& non-renewable waste)	42	38	30	19	4	0
Lignite	5	0	0	0	0	0
Gas	254	279	283	296	242	121
of which from H <sub>2</sub>	0	0	0	0	0	4
Oil	12	6	3	2	1	1
Biomass (& renewable waste)	34	64	88	119	166	182
Geothermal	0	4	16	35	86	141
Hydrogen	0	6	15	25	48	57
<b>CHP by producer</b>						
Main activity producers	194	221	231	250	262	238
Autoproducers	153	177	205	246	286	264
<b>Total generation</b>	<b>5,203</b>	<b>5,373</b>	<b>5,694</b>	<b>6,221</b>	<b>7,252</b>	<b>7,151</b>
Fossil	3,340	3,162	2,662	2,032	1,224	267
Hard coal (& non-renewable waste)	810	515	308	229	88	0
Lignite	946	709	374	27	0	0
Gas	1,487	1,885	1,841	1,756	1,129	264
Oil	87	46	35	18	5	3
Diesel	9	7	5	3	1	0
Nuclear	905	508	374	53	0	0
Hydrogen	0	6	15	25	48	61
of which renewable H <sub>2</sub>	0	2	7	17	40	58
<b>Renewables (w/o renewable hydrogen)</b>	<b>958</b>	<b>1,697</b>	<b>2,743</b>	<b>4,111</b>	<b>5,980</b>	<b>6,823</b>
Hydro	691	741	765	776	782	782
Wind	157	559	1,095	1,527	2,153	2,306
PV	9	203	542	964	1,252	1,318
Biomass (& renewable waste)	76	109	121	144	180	198
Geothermal	24	53	103	208	387	550
Solar thermal power plants	1	16	87	415	957	1,209
Ocean energy	0	17	29	77	269	460
Distribution losses	358	399	414	431	453	446
Own consumption electricity	382	362	374	388	411	405
Electricity for hydrogen production	0	31	162	477	1,178	1,690
Electricity for synfuel production	0	0	0	0	0	0
<b>Final energy consumption (electricity)</b>	<b>4,459</b>	<b>4,578</b>	<b>4,741</b>	<b>4,922</b>	<b>5,207</b>	<b>4,607</b>
Fluctuating RES (PV, Wind, Ocean)	166	778	1,666	2,568	3,674	4,085
Share of fluctuating RES	3%	14%	29%	41%	51%	57%
<b>RES share (domestic generation)</b>	<b>18%</b>	<b>32%</b>	<b>48%</b>	<b>66%</b>	<b>83%</b>	<b>96%</b>

Table 13.2.9 OECD North America: Final energy consumption in transport PJ/a

	2012	2020	2025	2030	2040	2050
<b>Road</b>	<b>25,564</b>	<b>22,925</b>	<b>20,439</b>	<b>17,497</b>	<b>11,049</b>	<b>7,927</b>
Fossil fuels	24,388	21,554	18,129	13,380	4,003	700
Biofuels	1,199	1,185	1,131	1,089	583	453
Synfuels	0	0	0	0	0	0
Natural gas	32	10	59	128	183	200
Hydrogen	0	11	178	794	2,113	3,212
<b>Electricity</b>	<b>5</b>	<b>166</b>	<b>943</b>	<b>2,106</b>	<b>4,168</b>	<b>3,362</b>
<b>Rail</b>	<b>663</b>	<b>676</b>	<b>697</b>	<b>686</b>	<b>710</b>	<b>559</b>
Fossil fuels	624	567	489	389	259	84
Biofuels	0	34	63	81	103	56
Synfuels	0	0	0	0	0	0
Electricity	39	75	145	217	348	418
<b>Navigation</b>	<b>550</b>	<b>566</b>	<b>576</b>	<b>598</b>	<b>637</b>	<b>696</b>
Fossil fuels	550	550	548	528	437	357
Biofuels	0	16	28	70	200	339
Synfuels	0	0	0	0	0	0
<b>Aviation</b>	<b>2,161</b>	<b>2,047</b>	<b>1,922</b>	<b>1,762</b>	<b>1,582</b>	<b>1,678</b>
Fossil fuels	2,161	2,047	1,868	1,596	1,190	1,007
Biofuels	0	0	54	166	392	671
Synfuels	0	0	0	0	0	0
<b>Total (incl. pipelines)</b>	<b>29,748</b>	<b>26,878</b>	<b>24,224</b>	<b>21,060</b>	<b>14,347</b>	<b>11,083</b>
Fossil fuels	27,723	24,717	21,034	15,894	5,899	2,148
Biofuels (incl. biogas)	1,199	1,235	1,276	1,405	1,278	1,520
Synfuels	0	0	0	0	0	0
Natural gas	842	670	640	624	487	271
Hydrogen	0	11	178	794	2,113	3,212
Electricity	44	243	1,097	2,343	4,582	3,932
<b>Total RES</b>	<b>1,147</b>	<b>1,316</b>	<b>1,891</b>	<b>3,486</b>	<b>6,835</b>	<b>8,396</b>
<b>RES share</b>	<b>4%</b>	<b>5%</b>	<b>8%</b>	<b>17%</b>	<b>48%</b>	<b>76%</b>

Table 13.2.10 OECD North America: Heat supply PJ/a

	2012	2020	2025	2030	2040	2050
<b>District heating plants</b>	<b>0</b>	<b>103</b>	<b>352</b>	<b>653</b>	<b>1,553</b>	<b>1,823</b>
Fossil fuels	0	0	0	0	0	0
Biomass	0	55	146	224	378	152
Solar collectors	0	25	114	239	642	904
Geothermal	0	23	92	189	534	768
<b>Heat from CHP<sup>1</sup></b>	<b>867</b>	<b>1,119</b>	<b>1,456</b>	<b>1,903</b>	<b>2,678</b>	<b>3,120</b>
Fossil fuels	779	799	842	888	762	406
Biomass	88	247	370	550	884	1,188
Geothermal	0	32	135	286	688	1,105
Hydrogen	0	42	108	179	344	421
<b>Direct heating</b>	<b>19,082</b>	<b>20,003</b>	<b>19,331</b>	<b>18,515</b>	<b>15,967</b>	<b>13,373</b>
Fossil fuels	15,798	15,559	13,652	11,415	5,645	1,597
Biomass	1,697	1,896	1,800	1,593	1,143	592
Solar collectors	68	549	1,345	2,309	3,979	4,372
Geothermal	0	73	111	149	219	208
Heat pumps <sup>2</sup>	14	245	625	1,135	2,630	3,736
Electric direct heating	1,506	1,680	1,751	1,778	1,925	2,201
Hydrogen	0	0	47	137	426	667
<b>Total heat supply<sup>3</sup></b>	<b>19,949</b>	<b>21,226</b>	<b>21,139</b>	<b>21,072</b>	<b>20,198</b>	<b>18,316</b>
Fossil fuels	16,577	16,358	14,494	12,303	6,407	2,003
Biomass	1,784	2,198	2,316	2,367	2,405	1,932
Solar collectors	68	574	1,459	2,548	4,620	5,275
Geothermal	0	128	338	625	1,440	2,080
Heat pumps <sup>2</sup>	14	245	625	1,135	2,630	3,736
Electric direct heating	1,506	1,680	1,751	1,778	1,925	2,201
Hydrogen	0	42	156	316	770	1,089
<b>RES share (including RES electricity)</b>	<b>11%</b>	<b>18%</b>	<b>27%</b>	<b>39%</b>	<b>67%</b>	<b>89%</b>

<sup>1</sup> public CHP and CHP autoproduction / <sup>2</sup> heat from ambient energy and electricity use / <sup>3</sup> incl. process heat, cooking

Table 13.2.10: OECD North America: Installed capacity GW

	2012	2020	2025	2030	2040	2050
<b>Total generation</b>	<b>1,356</b>	<b>1,472</b>	<b>1,879</b>	<b>2,328</b>	<b>2,814</b>	<b>2,785</b>
<b>Fossil</b>	<b>932</b>	<b>801</b>	<b>761</b>	<b>693</b>	<b>626</b>	<b>416</b>
Hard coal (& non-renewable waste)	163	87	51	46	18	0
Lignite	188	122	64	5	0	0
Gas (w/o H <sub>2</sub> )	495	545	606	621	599	412
Oil	11	7	34	18	7	4
Diesel	7	5	3	2	0	0
Nuclear	124	66	48	7	0	0
Hydrogen (fuel cells, gas power plants, gas CHP)	0	2	4	7	13	17
<b>Renewables</b>	<b>300</b>	<b>604</b>	<b>1,066</b>	<b>1,621</b>	<b>2,175</b>	<b>2,353</b>
Hydro	204	213	219	225	230	233
Wind	67	206	397	544	730	763
of which wind offshore	0	5	14	30	124	156
PV	9	145	379	668	850	869
Biomass (& renewable waste)	16	21	23	27	33	62
Geothermal	4	8	15	31	56	80
Solar thermal power plants	1	5	25	101	181	198
Ocean energy	0	5	9	26	96	149
Fluctuating RES (PV, Wind, Ocean)	75	366	784	1,238	1,675	1,780
Share of fluctuating RES	6%	24%	42%	53%	60%	64%
<b>RES share (domestic generation)</b>	<b>22%</b>	<b>41%</b>	<b>57%</b>	<b>70%</b>	<b>77%</b>	<b>84%</b>

Table 13.2.12: OECD North America: Final energy demand PJ/a

	2012	2020	2025	2030	2040	2050
<b>Total (incl. non-energy use)</b>	<b>73,586</b>	<b>72,407</b>	<b>68,013</b>	<b>62,729</b>	<b>50,750</b>	<b>41,781</b>
<b>Total energy use</b>	<b>67,806</b>	<b>65,608</b>	<b>61,544</b>	<b>56,593</b>	<b>45,438</b>	<b>37,264</b>
<b>Transport</b>	<b>29,748</b>	<b>26,878</b>	<b>24,224</b>	<b>21,060</b>	<b>14,347</b>	<b>11,083</b>
Oil products	27,723	24,717	21,034	15,894	5,899	2,148
Natural gas	842	670	640	624	487	271
Biofuels	1,199	1,235	1,276	1,405	1,278	1,520
Synfuels	0	0	0	0	0	0
Electricity	44	243	1,097	2,343	4,582	3,932
RES electricity	8	77	530	1,554	3,803	3,784
Hydrogen	0	11	178	794	2,113	3,212
<b>RES share Transport</b>	<b>4%</b>	<b>5%</b>	<b>9%</b>	<b>17%</b>	<b>48%</b>	<b>76%</b>
<b>Industry</b>	<b>14,131</b>	<b>14,805</b>	<b>14,269</b>	<b>13,560</b>	<b>11,765</b>	<b>9,918</b>
Electricity	4,191	4,746	4,910	4,862	4,931	5,033
RES electricity	772	1,501	2,371	3,239	4,093	4,843
Public district heat	241	284	294	304	307	276
RES district heat	15	105	163	206	262	262
Hard coal & lignite	988	833	633	392	111	0
Oil products	1,406	1,103	796	514	205	8
Gas	5,943	5,966	5,419	5,025	3,281	1,684
Solar	0	150</				

# OECD NORTH AMERICA: ADVANCED ENERGY [R]EVOLUTION SCENARIO

Table 13.2.15 OECD North America: Electricity generation TWh/a

	2012	2020	2025	2030	2040	2050
<b>Power plants</b>	<b>4,856</b>	<b>5,065</b>	<b>5,755</b>	<b>6,473</b>	<b>7,833</b>	<b>8,574</b>
Hard coal (& non-renewable waste)	765	364	159	35	24	0
Lignite	941	709	374	27	0	0
Gas	1,234	1,607	1,558	1,449	851	146
<i>of which from H<sup>1</sup></i>	0	0	16	30	103	146
Oil	75	40	31	16	4	0
Diesel	9	7	5	3	1	0
Nuclear	905	508	374	53	0	0
Biomass (& renewable waste)	42	44	34	26	14	16
Hydro	691	741	765	776	782	782
Wind	157	674	1,417	1,858	2,524	2,942
<i>of which wind offshore</i>	0	20	60	143	582	774
PV	9	275	779	1,289	1,531	1,852
Geothermal	24	57	106	223	457	588
Solar thermal power plants	1	22	118	612	1,312	1,648
Ocean energy	0	18	34	96	343	600
<b>Combined heat and power plants</b>	<b>347</b>	<b>398</b>	<b>435</b>	<b>496</b>	<b>548</b>	<b>502</b>
Hard coal (& non-renewable waste)	42	38	30	19	4	0
Lignite	5	0	0	0	0	0
Gas	254	279	283	296	242	122
<i>of which from H<sup>1</sup></i>	0	0	3	6	29	122
Oil	12	6	3	2	1	0
Biomass (& renewable waste)	34	64	88	119	166	182
Geothermal	0	4	16	35	86	141
Hydrogen	0	6	15	25	48	57
<i>CHP by producer</i>						
Main activity producers	194	221	231	250	262	238
Autoproducers	153	177	205	246	286	264
<b>Total generation</b>	<b>5,203</b>	<b>5,463</b>	<b>6,190</b>	<b>6,969</b>	<b>8,381</b>	<b>9,076</b>
Fossil	3,340	3,049	2,425	1,812	995	0
Hard coal (& non-renewable waste)	810	402	189	54	28	0
Lignite	946	709	374	27	0	0
Gas	1,487	1,885	1,823	1,710	961	0
Oil	87	46	35	18	5	0
Diesel	9	7	5	3	1	0
Nuclear	905	508	374	53	0	0
Hydrogen	0	6	33	60	180	325
<i>of which renewable H<sup>1</sup></i>	0	2	18	44	158	325
<b>Renewables (w/o renewable hydrogen)</b>	<b>958</b>	<b>1,901</b>	<b>3,358</b>	<b>5,033</b>	<b>7,216</b>	<b>8,751</b>
Hydro	691	741	765	776	782	782
Wind	157	674	1,417	1,858	2,524	2,942
PV	9	275	779	1,289	1,531	1,852
Biomass (& renewable waste)	76	109	121	144	180	198
Geothermal	24	62	123	258	544	730
Solar thermal power plants	1	22	118	612	1,312	1,648
Ocean energy	0	18	34	96	343	600
Distribution losses	358	399	414	431	453	446
Own consumption electricity	382	362	374	388	411	405
Electricity for hydrogen production	0	47	443	782	1,599	2,720
Electricity for synfuel production	0	9	22	29	275	501
<b>Final energy consumption (electricity)</b>	<b>4,459</b>	<b>4,643</b>	<b>4,934</b>	<b>5,325</b>	<b>5,650</b>	<b>5,002</b>
Fluctuating RES (PV, Wind, Ocean)	166	968	2,230	3,243	4,398	5,393
Share of fluctuating RES	3%	18%	36%	47%	52%	59%
<b>RES share (domestic generation)</b>	<b>18%</b>	<b>35%</b>	<b>55%</b>	<b>73%</b>	<b>88%</b>	<b>100%</b>

Table 13.2.16 OECD North America: Final energy consumption in transport PJ/a

	2012	2020	2025	2030	2040	2050
<b>Road</b>	<b>25,564</b>	<b>22,542</b>	<b>19,288</b>	<b>15,624</b>	<b>8,504</b>	<b>5,477</b>
Fossil fuels	24,388	21,070	16,155	10,809	1,795	0
Biofuels	1,139	1,150	1,159	989	702	278
Synfuels	0	12	28	31	223	138
Natural gas	32	0	0	0	0	0
Hydrogen	0	52	660	1,247	2,049	2,501
Electricity	5	270	1,314	2,579	3,957	2,699
<b>Rail</b>	<b>663</b>	<b>743</b>	<b>885</b>	<b>1,043</b>	<b>1,401</b>	<b>1,399</b>
Fossil fuels	624	536	427	299	130	0
Biofuels	0	16	41	51	66	47
Synfuels	0	0	1	2	23	2
Electricity	39	190	416	691	1,184	1,329
<b>Navigation</b>	<b>550</b>	<b>566</b>	<b>576</b>	<b>598</b>	<b>637</b>	<b>696</b>
Fossil fuels	550	561	567	517	414	0
Biofuels	0	6	8	78	169	465
Synfuels	0	0	0	2	54	231
<b>Aviation</b>	<b>2,161</b>	<b>2,026</b>	<b>1,865</b>	<b>1,639</b>	<b>1,249</b>	<b>1,091</b>
Fossil fuels	2,161	2,016	1,846	1,426	812	0
Biofuels	0	10	18	207	332	729
Synfuels	0	0	0	6	105	361
<b>Total (incl. pipelines)</b>	<b>29,748</b>	<b>26,549</b>	<b>23,226</b>	<b>19,443</b>	<b>12,373</b>	<b>9,009</b>
Fossil fuels	27,723	24,183	18,995	13,051	3,152	0
Biofuels (incl. biogas)	1,139	1,182	1,227	1,325	1,269	1,520
Synfuels	0	13	30	41	403	753
Natural gas	842	653	657	454	200	0
Hydrogen	0	52	660	1,247	2,049	2,501
Electricity	44	466	1,758	3,325	5,300	4,236
<b>Total RES</b>	<b>1,147</b>	<b>1,367</b>	<b>2,562</b>	<b>4,691</b>	<b>8,082</b>	<b>9,009</b>
<b>RES share</b>	<b>4%</b>	<b>5%</b>	<b>11%</b>	<b>24%</b>	<b>65%</b>	<b>100%</b>

Table 13.2.17 OECD North America: Heat supply PJ/a

	2012	2020	2025	2030	2040	2050
<b>District heating plants</b>	<b>0</b>	<b>103</b>	<b>352</b>	<b>653</b>	<b>1,553</b>	<b>1,824</b>
Fossil fuels	0	0	0	0	0	0
Biomass	0	55	146	224	378	152
Solar collectors	0	25	114	239	642	904
Geothermal	0	23	92	189	534	768
<b>Heat from CHP<sup>1</sup></b>	<b>867</b>	<b>1,119</b>	<b>1,456</b>	<b>1,903</b>	<b>2,678</b>	<b>3,118</b>
Fossil fuels	779	799	835	871	672	0
Biomass	88	247	370	550	884	1,188
Geothermal	0	32	135	286	688	1,105
Hydrogen	0	42	116	196	434	825
<b>Direct heating</b>	<b>19,082</b>	<b>20,003</b>	<b>19,331</b>	<b>18,515</b>	<b>15,967</b>	<b>13,375</b>
Fossil fuels	15,798	15,559	13,574	11,317	5,310	0
Biomass	1,697	1,896	1,800	1,593	1,143	592
Solar collectors	68	549	1,358	2,321	4,033	4,388
Geothermal	0	73	111	149	219	203
Heat pumps <sup>2</sup>	14	245	625	1,135	2,630	3,737
Electric direct heating	1,506	1,680	1,751	1,797	1,971	2,351
Hydrogen	0	0	113	203	661	2,103
<b>Total heat supply<sup>3</sup></b>	<b>19,949</b>	<b>21,226</b>	<b>21,139</b>	<b>21,072</b>	<b>20,198</b>	<b>18,316</b>
Fossil fuels	16,577	16,358	14,409	12,188	5,982	0
Biomass	1,784	2,198	2,316	2,367	2,405	1,932
Solar collectors	68	574	1,472	2,561	4,675	5,292
Geothermal	0	128	338	625	1,440	2,076
Heat pumps <sup>2</sup>	14	245	625	1,135	2,630	3,737
Electric direct heating	1,506	1,680	1,751	1,797	1,971	2,351
Hydrogen	0	42	229	398	1,095	2,928
<b>RES share (including RES electricity)</b>	<b>11%</b>	<b>18%</b>	<b>28%</b>	<b>40%</b>	<b>69%</b>	<b>100%</b>

<sup>1</sup> public CHP and CHP autoproduction / <sup>2</sup> heat from ambient energy and electricity use / <sup>3</sup> incl. process heat, cooking

Table 13.2.18: OECD North America: Installed capacity GW

	2012	2020	2025	2030	2040	2050
<b>Total generation</b>	<b>1,356</b>	<b>1,554</b>	<b>2,197</b>	<b>2,768</b>	<b>3,290</b>	<b>3,629</b>
<b>Fossil</b>	<b>932</b>	<b>785</b>	<b>774</b>	<b>712</b>	<b>575</b>	<b>0</b>
Hard coal (& non-renewable waste)	163	68	38	12	12	0
Lignite	188	121	65	5	0	0
Gas (w/o H <sup>1</sup> )	495	547	632	671	552	0
Oil	75	41	34	21	8	0
Diesel	11	7	5	3	2	0
Nuclear	124	66	48	7	0	0
Hydrogen (fuel cells, gas power plants, gas CHP)	0	2	10	21	89	528
<b>Renewables</b>	<b>300</b>	<b>702</b>	<b>1,365</b>	<b>2,028</b>	<b>2,626</b>	<b>3,102</b>
Hydro	204	213	219	227	239	257
Wind	67	248	514	661	852	971
<i>of which wind offshore</i>	0	6	17	40	159	209
PV	9	197	546	893	1,038	1,224
Biomass (& renewable waste)	16	21	23	27	33	37
Geothermal	4	9	20	38	95	134
Solar thermal power plants	1	7	34	149	248	286
Ocean energy	0	6	11	33	122	193
Fluctuating RES (PV, Wind, Ocean)	75	451	1,070	1,586	2,011	2,387
Share of fluctuating RES	6%	29%	49%	57%	61%	66%
<b>RES share (domestic generation)</b>	<b>22%</b>	<b>45%</b>	<b>62%</b>	<b>73%</b>	<b>80%</b>	<b>85%</b>

Table 13.2.19: OECD North America: Final energy demand PJ/a

	2012	2020	2025	2030	2040	2050
<b>Total (incl. non-energy use)</b>	<b>73,586</b>	<b>72,086</b>	<b>67,040</b>	<b>61,433</b>	<b>49,361</b>	<b>40,402</b>
<b>Total energy use</b>	<b>67,806</b>	<b>65,286</b>	<b>60,571</b>	<b>55,297</b>	<b>44,478</b>	<b>35,885</b>
<b>Transport</b>	<b>29,748</b>	<b>26,549</b>	<b>23,226</b>	<b>19,443</b>	<b>12,373</b>	<b>9,009</b>
Oil products	27,723	24,183	16,995	13,051	3,152	0
Natural gas	842	653	657	454	200	0
Biofuels	1,139	1,182	1,227	1,325	1,269	1,520
Synfuels	0	13	30	41	403	753
Electricity	44	466	1,758	3,325	5,300	4,236
RES electricity	8	162	959	2,426	4,658	4,236
Hydrogen	0	52	660	1,247	2,049	2,501
<b>RES share Transport</b>	<b>4%</b>	<b>5%</b>	<b>11%</b>	<b>24%</b>	<b>65%</b>	<b>100%</b>
<b>Industry</b>	<b>14,131</b>	<b>14,805</b>	<b>14,289</b>	<b>13,623</b>	<b>11,875</b>	<b>10,049</b>
Electricity	4,191	4,748	4,910	4,994	5,138	5,374
RES electricity	772	1,653	2,678	3,644	4,515	5,374
Public district heat	241	284	294	304	307	276
RES district heat	15	105	164	208	267	276
Hard coal & lignite	988	833	633	387	111	0
Oil products	1,406	1,103	796	479	154	0

# OECD NORTH AMERICA: INVESTMENT AND EMPLOYMENT

**Table 13.2.22: OECD North America: Investments in electricity generation**

REF	UNIT	2012-2020	2021-2030	2031-2040	2041-2050	2012-2050	UNIT	ANNUAL AVERAGE 2012-2050
Fossil (w/o CHP)	billion \$	354.1	462.1	606.2	458.1	1,880.4	billion \$/a	48.2
Nuclear	billion \$	123.3	155.4	129.1	160.3	568.2	billion \$/a	14.6
CHP (fossil + renewable)	billion \$	88.1	47.8	11.9	5.9	153.7	billion \$/a	3.9
Renewables (w/o CHP)	billion \$	390.6	398.3	433.5	462.0	1,674.5	billion \$/a	42.9
<b>Total</b>	<b>billion \$</b>	<b>946.2</b>	<b>1,063.6</b>	<b>1,180.7</b>	<b>1,086.3</b>	<b>4,276.8</b>	<b>billion \$/a</b>	<b>109.7</b>
Conventional (fossil & nuclear)	billion \$	555.6	658.0	746.2	621.9	2,581.6	billion \$/a	66.2
Renewables	billion \$	390.5	405.6	434.5	464.5	1,695.2	billion \$/a	43.5
Biomass	billion \$	40.1	34.5	45.2	43.4	163.3	billion \$/a	4.2
Hydro	billion \$	120.1	139.0	97.1	105.2	461.4	billion \$/a	11.8
Wind	billion \$	109.5	139.7	182.8	192.0	623.9	billion \$/a	16.0
PV	billion \$	64.4	44.6	66.5	53.2	228.8	billion \$/a	5.9
Geothermal	billion \$	32.7	24.7	18.4	25.4	101.1	billion \$/a	2.6
Solar thermal power plants	billion \$	23.7	21.0	20.5	40.7	105.9	billion \$/a	2.7
Ocean energy	billion \$	0.0	2.2	4.0	4.5	10.7	billion \$/a	0.3
<b>E[R]</b>								
Fossil (w/o CHP)	billion \$	183.9	213.6	319.0	96.9	813.5	billion \$/a	20.9
Nuclear	billion \$	4.5	0.0	0.0	0.0	4.5	billion \$/a	0.1
CHP (fossil + renewable)	billion \$	134.2	143.6	134.0	230.8	642.6	billion \$/a	16.5
Renewables (w/o CHP)	billion \$	802.4	2,306.2	1,979.3	1,759.9	6,847.7	billion \$/a	175.6
<b>Total</b>	<b>billion \$</b>	<b>1,124.9</b>	<b>2,663.4</b>	<b>2,432.3</b>	<b>2,087.6</b>	<b>8,308.2</b>	<b>billion \$/a</b>	<b>213.0</b>
Conventional (fossil & nuclear)	billion \$	280.9	266.4	333.6	105.2	986.1	billion \$/a	25.3
Renewables	billion \$	844.0	2,397.0	2,098.7	1,982.4	7,322.1	billion \$/a	187.7
Biomass	billion \$	41.9	49.3	59.4	139.8	290.4	billion \$/a	7.4
Hydro	billion \$	137.3	144.9	123.5	117.6	523.4	billion \$/a	13.4
Wind	billion \$	293.1	718.6	756.8	755.5	2,524.0	billion \$/a	64.7
PV	billion \$	249.9	696.1	327.5	424.6	1,698.1	billion \$/a	43.5
Geothermal	billion \$	60.4	190.3	183.5	211.0	645.1	billion \$/a	16.5
Solar thermal power plants	billion \$	28.0	497.7	411.0	202.3	1,139.0	billion \$/a	29.2
Ocean energy	billion \$	33.3	100.1	237.0	131.7	502.1	billion \$/a	12.9
<b>ADV E[R]</b>								
Fossil (w/o CHP)	billion \$	135.6	214.8	405.6	147.0	903.0	billion \$/a	23.2
Nuclear	billion \$	4.5	0.0	0.0	0.0	4.5	billion \$/a	0.1
CHP (fossil + renewable)	billion \$	134.2	146.2	136.4	142.7	559.4	billion \$/a	14.3
Renewables (w/o CHP)	billion \$	988.3	3,015.7	2,479.2	2,665.7	9,158.9	billion \$/a	234.8
<b>Total</b>	<b>billion \$</b>	<b>1,272.7</b>	<b>3,376.7</b>	<b>3,021.1</b>	<b>2,955.4</b>	<b>10,625.8</b>	<b>billion \$/a</b>	<b>272.5</b>
Conventional (fossil & nuclear)	billion \$	232.7	270.1	422.5	156.1	1,081.5	billion \$/a	27.7
Renewables	billion \$	1,039.9	3,106.6	2,598.6	2,799.2	9,544.3	billion \$/a	244.7
Biomass	billion \$	41.9	49.3	59.4	50.8	201.4	billion \$/a	5.2
Hydro	billion \$	137.3	153.8	146.4	164.0	601.5	billion \$/a	15.4
Wind	billion \$	372.6	867.4	879.2	1,054.1	3,173.4	billion \$/a	81.4
PV	billion \$	339.4	932.2	343.1	694.0	2,308.7	billion \$/a	59.2
Geothermal	billion \$	74.6	237.7	359.8	311.7	983.7	billion \$/a	25.2
Solar thermal power plants	billion \$	37.2	738.3	506.6	351.6	1,633.7	billion \$/a	41.9
Ocean energy	billion \$	36.9	127.7	304.1	173.0	641.8	billion \$/a	16.5

**Table 13.2.23: OECD North America: Investments in renewable heat generation**

REF	UNIT	2012-2020	2021-2030	2031-2040	2041-2050	2012-2050	UNIT	ANNUAL AVERAGE 2012-2050
Heat pumps	billion \$	1.2	1.3	0.4	0.4	3.3	billion \$/a	0.1
Deep geothermal	billion \$	0.0	0.0	0.0	0.0	0.0	billion \$/a	0.0
Solar thermal	billion \$	27.7	48.7	67.2	97.4	241.1	billion \$/a	6.2
Biomass	billion \$	135.9	136.6	69.9	72.0	414.5	billion \$/a	10.6
<b>Total</b>	<b>billion \$</b>	<b>164.8</b>	<b>186.6</b>	<b>137.6</b>	<b>169.8</b>	<b>658.9</b>	<b>billion \$/a</b>	<b>16.9</b>
<b>E[R]</b>								
Heat pumps	billion \$	62.0	263.3	460.9	527.1	1,313.2	billion \$/a	33.7
Deep geothermal	billion \$	31.8	25.1	231.0	198.0	485.8	billion \$/a	12.5
Solar thermal	billion \$	156.0	503.3	578.0	348.7	1,586.0	billion \$/a	40.7
Biomass	billion \$	139.4	10.3	12.1	0.0	161.8	billion \$/a	4.1
<b>Total</b>	<b>billion \$</b>	<b>389.2</b>	<b>802.0</b>	<b>1,281.9</b>	<b>1,073.8</b>	<b>3,546.9</b>	<b>billion \$/a</b>	<b>90.9</b>
<b>ADV E[R]</b>								
Heat pumps	billion \$	62.0	263.3	460.9	527.3	1,313.4	billion \$/a	33.7
Deep geothermal	billion \$	31.8	25.1	231.0	198.2	486.1	billion \$/a	12.5
Solar thermal	billion \$	156.0	507.0	589.0	347.0	1,599.1	billion \$/a	41.0
Biomass	billion \$	139.4	10.3	12.1	0.0	161.8	billion \$/a	4.1
<b>Total</b>	<b>billion \$</b>	<b>389.2</b>	<b>805.7</b>	<b>1,292.9</b>	<b>1,072.5</b>	<b>3,560.3</b>	<b>billion \$/a</b>	<b>91.3</b>

**Table 13.2.24: OECD North America: Total employment in the energy sector** THOUSAND JOBS

By sector	REFERENCE SCENARIO				ADV E[R] SCENARIO		
	2015	2020	2025	2030	2020	2025	2030
Construction and installation	138	83	90	85	388	458	442
Manufacturing	119	75	72	58	437	516	533
Operations and maintenance	380	402	405	407	443	535	623
Fuel supply (domestic)	551	526	514	502	540	513	475
Coal and gas export	-	-	-	-	-	-	-
Solar and geothermal heat	89	59	71	68	243	753	691
<b>Total jobs (thousands)</b>	<b>1,278</b>	<b>1,145</b>	<b>1,152</b>	<b>1,120</b>	<b>2,051</b>	<b>2,774</b>	<b>2,764</b>
<b>By technology</b>							
Coal	294	253	228	209	246	177	135
Gas, oil & diesel	175	178	180	176	162	166	157
Nuclear	84	82	81	80	96	101	110
<b>Renewable</b>	<b>725</b>	<b>631</b>	<b>662</b>	<b>654</b>	<b>1,547</b>	<b>2,330</b>	<b>2,363</b>
Biomass	276	296	313	328	391	459	455
Hydro	60	57	59	58	48	48	51
Wind	129	116	122	110	341	434	486
PV	164	93	86	70	468	517	512
Geothermal power	1.8	1.6	1.5	1.4	10	15	20
Solar thermal power	5.5	6.5	7.2	10.0	29	71	102
Ocean	0.6	2.3	2.7	8.7	16.6	32	46
Solar - heat	74	48	60	59	186	636	544
Geothermal & heat pump	14.7	10.7	10.2	9.6	57	117	146
<b>Total jobs (thousands)</b>	<b>1,278</b>	<b>1,145</b>	<b>1,152</b>	<b>1,120</b>	<b>2,051</b>	<b>2,774</b>	<b>2,764</b>

# LATIN AMERICA: REFERENCE SCENARIO

**Table 13.3.1 Latin America: Electricity generation TWh/a**

	2012	2020	2025	2030	2040	2050
<b>Power plants</b>	<b>1,152</b>	<b>1,495</b>	<b>1,742</b>	<b>1,989</b>	<b>2,490</b>	<b>2,904</b>
Hard coal (& non-renewable waste)	31	70	80	90	125	234
Lignite	7	8	8	9	10	11
Gas	198	247	340	434	639	778
of which from H <sub>2</sub>	0	0	0	0	0	0
Oil	121	95	75	55	33	15
Diesel	29	33	37	41	54	63
Nuclear	22	34	41	48	58	71
Biomass (& renewable waste)	10	27	37	46	66	75
Hydro	722	921	1,029	1,137	1,319	1,400
Wind	8	48	73	96	130	170
of which wind offshore	0	1	2	4	10	20
PV	0	6	10	15	24	36
Geothermal	4	6	10	13	21	25
Solar thermal power plants	0	0	2	3	11	23
Ocean energy	0	0	0	0	1	2
<b>Combined heat and power plants</b>	<b>63</b>	<b>72</b>	<b>75</b>	<b>79</b>	<b>85</b>	<b>92</b>
Hard coal (& non-renewable waste)	1	0	0	0	0	0
Lignite	0	0	0	0	0	0
Gas	16	17	16	16	15	15
of which from H <sub>2</sub>	0	0	0	0	0	0
Oil	6	7	7	7	7	8
Diesel	29	33	37	41	54	63
Nuclear	22	34	41	48	58	71
Hydrogen	0	0	0	0	0	0
of which renewable H <sub>2</sub>	0	0	0	0	0	0
<b>CHP by producer</b>						
Main activity producers	0	0	0	0	0	0
Autoproducers	63	72	75	78	85	92
<b>Total generation</b>	<b>1,216</b>	<b>1,567</b>	<b>1,817</b>	<b>2,067</b>	<b>2,576</b>	<b>2,996</b>
Fossil	409	476	564	652	894	1,124
Hard coal (& non-renewable waste)	32	70	81	90	125	234
Lignite	8	8	9	9	10	11
Gas	213	264	356	449	654	793
Oil	127	101	82	62	40	23
Diesel	29	33	37	41	54	63
Nuclear	22	34	41	48	58	71
Hydrogen	0	0	0	0	0	0
of which renewable H <sub>2</sub>	0	0	0	0	0	0
<b>Renewables (w/o renewable hydrogen)</b>	<b>784</b>	<b>1,057</b>	<b>1,212</b>	<b>1,368</b>	<b>1,633</b>	<b>1,801</b>
Hydro	722	921	1,029	1,137	1,319	1,400
Wind	8	48	73	96	130	170
PV	0	6	10	15	24	36
Biomass (& renewable waste)	50	75	89	102	129	144
Geothermal	4	6	10	13	21	25
Solar thermal power plants	0	0	2	3	11	23
Ocean energy	0	0	0	0	1	2
Distribution losses	179	233	272	310	390	454
Own consumption electricity	50	55	53	52	42	42
Electricity for hydrogen production	0	0	0	0	0	0
Electricity for synfuel production	0	0	0	0	0	0
<b>Final energy consumption (electricity)</b>	<b>987</b>	<b>1,285</b>	<b>1,498</b>	<b>1,711</b>	<b>2,150</b>	<b>2,505</b>
Fluctuating RES (PV, Wind, Ocean)	8	54	83	113	155	208
Share of fluctuating RES	1%	3%	5%	5%	6%	7%
<b>RES share (domestic generation)</b>	<b>64%</b>	<b>67%</b>	<b>67%</b>	<b>66%</b>	<b>63%</b>	<b>60%</b>

**Table 13.3.2 Latin America: Final energy consumption in transport PJ/a**

	2012	2020	2025	2030	2040	2050
<b>Road</b>	<b>6,326</b>	<b>7,489</b>	<b>8,286</b>	<b>9,093</b>	<b>10,099</b>	<b>9,856</b>
Fossil fuels	5,561	6,292	6,792	7,303	7,863	7,480
Biofuels	557	944	1,215	1,486	1,836	1,856
Synfuels	0	0	0	0	0	0
Natural gas	207	252	273	295	384	494
Hydrogen	0	0	0	0	0	0
Electricity	0	2	5	8	16	26
<b>Rail</b>	<b>128</b>	<b>156</b>	<b>196</b>	<b>225</b>	<b>284</b>	<b>343</b>
Fossil fuels	109	137	176	204	261	317
Biofuels	0	0	0	0	0	0
Synfuels	0	0	0	0	0	0
Electricity	18	19	20	21	23	25
<b>Navigation</b>	<b>122</b>	<b>150</b>	<b>168</b>	<b>186</b>	<b>223</b>	<b>259</b>
Fossil fuels	122	150	168	186	223	259
Biofuels	0	0	0	0	0	0
Synfuels	0	0	0	0	0	0
<b>Aviation</b>	<b>200</b>	<b>252</b>	<b>288</b>	<b>324</b>	<b>386</b>	<b>418</b>
Fossil fuels	200	252	288	324	386	418
Biofuels	0	0	0	0	0	0
Synfuels	0	0	0	0	0	0
<b>Total (incl. pipelines)</b>	<b>6,839</b>	<b>8,135</b>	<b>9,037</b>	<b>9,939</b>	<b>11,126</b>	<b>11,035</b>
Fossil fuels	5,993	6,831	7,424	8,018	8,732	8,474
Biofuels (incl. biogas)	557	944	1,215	1,486	1,836	1,856
Synfuels	0	0	0	0	0	0
Natural gas	271	339	373	407	519	653
Hydrogen	0	0	0	0	0	0
Electricity	18	22	25	29	39	51
<b>Total RES</b>	<b>569</b>	<b>958</b>	<b>1,232</b>	<b>1,505</b>	<b>1,861</b>	<b>1,887</b>
<b>RES share</b>	<b>8%</b>	<b>12%</b>	<b>14%</b>	<b>15%</b>	<b>17%</b>	<b>17%</b>

**Table 13.3.3 Latin America: Heat supply PJ/a**

	2012	2020	2025	2030	2040	2050
<b>District heating plants</b>	<b>0</b>	<b>0</b>	<b>0</b>	<b>0</b>	<b>0</b>	<b>0</b>
Fossil fuels	0	0	0	0	0	0
Biomass	0	0	0	0	0	0
Solar collectors	0	0	0	0	0	0
Geothermal	0	0	0	0	0	0
<b>Heat from CHP<sup>1</sup></b>	<b>134</b>	<b>176</b>	<b>199</b>	<b>230</b>	<b>332</b>	<b>580</b>
Fossil fuels	60	67	68	69	73	81
Biomass	74	108	131	161	259	500
Geothermal	0	0	0	0	0	0
Hydrogen	0	0	0	0	0	0
<b>Direct heating</b>	<b>7,354</b>	<b>9,056</b>	<b>10,240</b>	<b>11,433</b>	<b>14,049</b>	<b>15,669</b>
Fossil fuels	4,221	5,568	6,430	7,311	9,092	10,167
Biomass	2,241	2,404	2,595	2,789	3,358	3,713
Solar collectors	22	54	74	94	149	220
Geothermal	0	0	0	0	0	0
Heat pumps <sup>2</sup>	0	0	0	0	0	0
Electric direct heating	870	1,030	1,140	1,240	1,450	1,570
Hydrogen	0	0	0	0	0	0
<b>Total heat supply<sup>3</sup></b>	<b>7,487</b>	<b>9,232</b>	<b>10,439</b>	<b>11,664</b>	<b>14,381</b>	<b>16,250</b>
Fossil fuels	4,281	5,635	6,499	7,380	9,165	10,247
Biomass	2,314	2,512	2,726	2,950	3,616	4,213
Solar collectors	22	54	74	94	149	220
Geothermal	0	0	0	0	0	0
Heat pumps <sup>2</sup>	0	0	0	0	0	0
Electric direct heating	870	1,030	1,140	1,240	1,450	1,570
Hydrogen	0	0	0	0	0	0
<b>RES share (including RES electricity)</b>	<b>39%</b>	<b>35%</b>	<b>34%</b>	<b>33%</b>	<b>33%</b>	<b>33%</b>

<sup>1</sup> public CHP and CHP autoproduction / <sup>2</sup> heat from ambient energy and electricity use / <sup>3</sup> incl. process heat, cooking

**Table 13.3.4: Latin America: Installed capacity GW**

	2012	2020	2025	2030	2040	2050
<b>Total generation</b>	<b>272</b>	<b>370</b>	<b>430</b>	<b>490</b>	<b>604</b>	<b>695</b>
<b>Fossil</b>	<b>103</b>	<b>135</b>	<b>155</b>	<b>175</b>	<b>223</b>	<b>268</b>
Hard coal (& non-renewable waste)	6	13	14	15	20	37
Lignite	2	2	2	2	2	2
Gas (w/o H <sub>2</sub> )	54	74	96	118	163	194
Oil	34	35	30	24	16	9
Diesel	8	11	13	16	22	26
Nuclear	3	5	5	6	8	9
Hydrogen (fuel cells, gas power plants, gas CHP)	0	0	0	0	0	0
<b>Renewables</b>	<b>166</b>	<b>231</b>	<b>270</b>	<b>309</b>	<b>374</b>	<b>418</b>
Hydro	148	192	217	242	285	304
Wind	4	16	23	31	40	51
of which wind offshore	0	0	1	1	2	5
PV	0	4	8	11	17	26
Biomass (& renewable waste)	14	18	20	22	26	29
Geothermal	1	1	1	2	3	4
Solar thermal power plants	0	0	0	1	3	5
Ocean energy	0	0	0	0	0	0
Fluctuating RES (PV, Wind, Ocean)	4	20	31	42	57	77
Share of fluctuating RES	1%	5%	7%	8%	9%	11%
<b>RES share (domestic generation)</b>	<b>61%</b>	<b>62%</b>	<b>63%</b>	<b>63%</b>	<b>62%</b>	<b>60%</b>

**Table 13.3.5: Latin America: Final energy demand PJ/a**

	2012	2020	2025	2030	2040	2050
<b>Total (incl. non-energy use)</b>	<b>20,497</b>	<b>24,678</b>	<b>27,531</b>	<b>30,383</b>	<b>35,460</b>	<b>37,865</b>
<b>Total energy use</b>	<b>18,999</b>	<b>23,122</b>	<b>25,974</b>	<b>28,826</b>	<b>33,903</b>	<b>36,308</b>
<b>Transport</b>	<b>6,839</b>	<b>8,135</b>	<b>9,037</b>	<b>9,939</b>	<b>11,126</b>	<b>11,035</b>
Oil products	5,993	6,831	7,424	8,018	8,732	8,474
Natural gas	271	339	373	407	519	653
Synfuels	557	944	1,215	1,486	1,836	1,856
Electricity	18	22	25	29	39	51
RES electricity	12	15	17	19	25	31
Hydrogen	0	0	0	0	0	0
<b>RES share Transport</b>	<b>8%</b>	<b>12%</b>	<b>14%</b>	<b>15%</b>	<b>17%</b>	<b>17%</b>
<b>Industry</b>	<b>6,962</b>	<b>8,680</b>	<b>9,690</b>	<b>10,699</b>	<b>12,817</b>	<b>14,215</b>
Electricity	1,599	1,947	2,267	2,536	3,134	3,729
RES electricity	1,012	1,347	1,512	1,678	1,988	2,241
Public district heat	1	2	2	2	2	3
RES district heat	1	2	2	2	2	2
Hard coal & lignite	373	708	813	917	1,110	1,147
Oil products	1,627	1,771	1,823	1,876	1,937	1,830
Gas	1,518	2,061	2,453	2,844	3,744	4,453
Solar	0	9	14	18	33	49
Biomass	1,874	2,131	2,319	2,506	2,857	3,004
Geothermal	0	0	0	0	0	0
Hydrogen	0	0	0	0	0	0
<b>RES share Industry</b>	<b>41%</b>	<b>40%</b>	<b>40%</b>	<b>39%</b>	<b>38%</b>	<b>37%</b>
<b>Other Sectors</b>	<b>5,198</b>	<b>6,306</b>	<b>7,247</b>	<b>8,187</b>	<b>9,960</b>	<b>11,059</b>
Electricity	1,987	2,607	3,100	3,593	4,565	5,240
RES electricity	1,269	1,758	2,068	2,377	2,8	

Table 13.3.8 Latin America: Electricity generation TWh/a

	2012	2020	2025	2030	2040	2050
<b>Power plants</b>	<b>1,152</b>	<b>1,378</b>	<b>1,517</b>	<b>1,681</b>	<b>2,235</b>	<b>2,812</b>
Hard coal (& non-renewable waste)	31	34	32	20	1	0
Lignite	7	7	5	1	0	0
Gas	198	229	221	204	107	50
of which from H <sub>2</sub>	0	0	0	0	0	15
Oil	121	79	59	15	2	0
Diesel	29	25	15	10	2	0
Nuclear	22	18	11	0	0	0
Biomass (& renewable waste)	10	30	42	66	122	188
Hydro	722	797	799	806	814	820
Wind	8	103	192	305	568	815
of which wind offshore	0	1	17	65	200	345
PV	0	45	95	150	313	451
Geothermal	4	10	14	17	31	37
Solar thermal power plants	0	2	30	85	255	415
Ocean energy	0	0	1	2	20	37
<b>Combined heat and power plants</b>	<b>63</b>	<b>81</b>	<b>114</b>	<b>160</b>	<b>288</b>	<b>400</b>
Hard coal (& non-renewable waste)	1	0	0	0	0	0
Lignite	0	0	0	0	0	0
Gas	16	21	29	46	93	130
of which from H <sub>2</sub>	0	0	0	2	5	68
Oil	6	6	3	0	0	0
Biomass (& renewable waste)	40	54	78	104	148	162
Geothermal	0	1	4	8	39	90
Hydrogen	0	0	0	1	7	18
<b>CHP by producer</b>						
Main activity producers	0	5	13	22	42	47
Autoproducers	63	76	101	138	246	353
<b>Total generation</b>	<b>1,216</b>	<b>1,459</b>	<b>1,631</b>	<b>1,840</b>	<b>2,523</b>	<b>3,213</b>
Fossil	409	401	365	294	201	98
Hard coal (& non-renewable waste)	32	34	33	20	1	0
Lignite	8	7	5	1	0	0
Gas	213	250	250	248	195	98
Oil	127	85	62	15	2	0
Diesel	29	25	15	10	2	0
Nuclear	22	18	11	0	0	0
Hydrogen	0	0	0	3	11	100
of which renewable H <sub>2</sub>	0	0	0	3	10	94
<b>Renewables (w/o renewable hydrogen)</b>	<b>784</b>	<b>1,040</b>	<b>1,255</b>	<b>1,543</b>	<b>2,310</b>	<b>3,015</b>
Hydro	722	797	799	806	814	820
Wind	8	103	192	305	568	815
PV	0	45	95	150	313	451
Biomass (& renewable waste)	50	83	120	170	270	350
Geothermal	4	11	18	25	70	127
Solar thermal power plants	0	2	30	85	255	415
Ocean energy	0	0	1	2	20	37
Distribution losses	179	209	220	231	254	280
Own consumption electricity	50	57	58	58	60	61
Electricity for hydrogen production	0	0	15	39	251	643
Electricity for synfuel production	0	0	0	0	0	0
<b>Final energy consumption (electricity)</b>	<b>987</b>	<b>1,195</b>	<b>1,341</b>	<b>1,515</b>	<b>1,961</b>	<b>2,231</b>
Fluctuating RES (PV, Wind, Ocean)	8	148	288	457	901	1,303
Share of fluctuating RES	1%	10%	18%	25%	36%	41%
<b>RES share (domestic generation)</b>	<b>64%</b>	<b>71%</b>	<b>77%</b>	<b>84%</b>	<b>92%</b>	<b>97%</b>

Table 13.3.9 Latin America: Final energy consumption in transport PJ/a

	2012	2020	2025	2030	2040	2050
<b>Road</b>	<b>6,326</b>	<b>7,326</b>	<b>7,177</b>	<b>6,836</b>	<b>5,886</b>	<b>5,053</b>
Fossil fuels	5,561	5,961	5,124	3,947	1,387	193
Biofuels	557	1,052	1,281	1,691	2,081	1,737
Synfuels	0	0	0	0	0	0
Natural gas	207	293	574	752	837	637
Hydrogen	0	0	36	68	543	863
Electricity	0	20	162	377	1,037	1,623
<b>Rail</b>	<b>128</b>	<b>143</b>	<b>146</b>	<b>146</b>	<b>173</b>	<b>170</b>
Fossil fuels	109	118	93	67	33	2
Biofuels	0	4	17	21	21	7
Synfuels	0	0	0	0	0	0
Electricity	18	21	35	58	119	162
<b>Navigation</b>	<b>122</b>	<b>164</b>	<b>188</b>	<b>205</b>	<b>258</b>	<b>307</b>
Fossil fuels	122	164	179	180	155	31
Biofuels	0	0	9	25	103	276
Synfuels	0	0	0	0	0	0
<b>Aviation</b>	<b>200</b>	<b>229</b>	<b>235</b>	<b>241</b>	<b>278</b>	<b>301</b>
Fossil fuels	200	229	228	217	167	30
Biofuels	0	0	7	24	111	271
Synfuels	0	0	0	0	0	0
<b>Total (incl. pipelines)</b>	<b>6,839</b>	<b>7,936</b>	<b>7,819</b>	<b>7,500</b>	<b>6,664</b>	<b>5,886</b>
Fossil fuels	5,993	6,472	5,624	4,411	1,742	256
Biofuels (incl. biogas)	557	1,056	1,315	1,761	2,317	2,291
Synfuels	0	0	0	0	0	0
Natural gas	271	367	646	821	894	663
Hydrogen	0	0	36	68	543	863
Electricity	18	41	198	438	1,169	1,814
<b>Total RES</b>	<b>569</b>	<b>1,085</b>	<b>1,495</b>	<b>2,186</b>	<b>3,892</b>	<b>4,881</b>
<b>RES share</b>	<b>8%</b>	<b>14%</b>	<b>19%</b>	<b>29%</b>	<b>58%</b>	<b>83%</b>

Table 13.3.10 Latin America: Heat supply PJ/a

	2012	2020	2025	2030	2040	2050
<b>District heating plants</b>	<b>0</b>	<b>3</b>	<b>9</b>	<b>22</b>	<b>78</b>	<b>109</b>
Fossil fuels	0	0	1	2	2	0
Biomass	0	2	6	15	49	49
Solar collectors	0	0	1	3	16	38
Geothermal	0	0	1	2	12	22
<b>Heat from CHP<sup>1</sup></b>	<b>134</b>	<b>228</b>	<b>380</b>	<b>595</b>	<b>1,389</b>	<b>2,532</b>
Fossil fuels	60	78	103	148	310	226
Biomass	74	142	245	365	676	1,172
Geothermal	0	8	31	70	345	785
Hydrogen	0	0	1	13	58	349
<b>Direct heating</b>	<b>7,354</b>	<b>8,535</b>	<b>8,149</b>	<b>8,344</b>	<b>7,923</b>	<b>6,660</b>
Fossil fuels	4,221	4,559	3,549	3,005	1,485	393
Biomass	2,241	2,589	2,825	2,980	2,831	2,513
Solar collectors	22	301	514	825	1,364	1,358
Geothermal	0	6	26	55	150	176
Heat pumps <sup>2</sup>	0	76	118	169	352	491
Electric direct heating	870	1,005	1,116	1,310	1,740	1,719
Hydrogen	0	0	0	0	0	9
<b>Total heat supply<sup>3</sup></b>	<b>7,487</b>	<b>8,766</b>	<b>8,538</b>	<b>8,961</b>	<b>9,390</b>	<b>9,301</b>
Fossil fuels	4,281	4,637	3,653	3,154	1,796	619
Biomass	2,314	2,733	3,076	3,359	3,557	3,734
Solar collectors	22	301	515	828	1,380	1,396
Geothermal	0	14	59	127	507	983
Heat pumps <sup>2</sup>	0	76	118	169	352	491
Electric direct heating	870	1,005	1,116	1,310	1,740	1,719
Hydrogen	0	0	1	13	58	359
<b>RES share (including RES electricity)</b>	<b>39%</b>	<b>44%</b>	<b>54%</b>	<b>63%</b>	<b>79%</b>	<b>93%</b>

<sup>1</sup> public CHP and CHP autoproduction / <sup>2</sup> heat from ambient energy and electricity use / <sup>3</sup> incl. process heat, cooking

Table 13.3.10: Latin America: Installed capacity GW

	2012	2020	2025	2030	2040	2050
<b>Total generation</b>	<b>272</b>	<b>391</b>	<b>474</b>	<b>560</b>	<b>837</b>	<b>1,073</b>
<b>Fossil</b>	<b>103</b>	<b>130</b>	<b>134</b>	<b>121</b>	<b>128</b>	<b>89</b>
Hard coal (& non-renewable waste)	6	7	7	4	0	0
Lignite	2	1	1	0	0	0
Gas (w/o H <sub>2</sub> )	54	84	98	107	126	89
Oil	34	29	22	6	1	0
Diesel	8	9	5	4	1	0
Nuclear	3	2	2	0	0	0
Hydrogen (fuel cells, gas power plants, gas CHP)	0	0	0	1	3	57
<b>Renewables</b>	<b>166</b>	<b>259</b>	<b>338</b>	<b>438</b>	<b>706</b>	<b>926</b>
Hydro	148	164	165	166	168	169
Wind	4	34	60	92	162	225
of which wind offshore	0	0	4	16	46	81
PV	0	35	71	111	227	332
Biomass (& renewable waste)	14	23	31	42	71	102
Geothermal	1	2	3	4	10	18
Solar thermal power plants	0	1	8	23	63	80
Ocean energy	0	0	0	1	6	10
Fluctuating RES (PV, Wind, Ocean)	4	69	132	203	394	557
Share of fluctuating RES	1%	18%	28%	36%	47%	52%
<b>RES share (domestic generation)</b>	<b>61%</b>	<b>66%</b>	<b>71%</b>	<b>78%</b>	<b>84%</b>	<b>86%</b>

Table 13.3.12: Latin America: Final energy demand PJ/a

	2012	2020	2025	2030	2040	2050
<b>Total (incl. non-energy use)</b>	<b>20,497</b>	<b>23,558</b>	<b>23,070</b>	<b>22,974</b>	<b>21,497</b>	<b>19,382</b>
<b>Total energy use</b>	<b>18,999</b>	<b>22,001</b>	<b>21,545</b>	<b>21,464</b>	<b>20,018</b>	<b>17,903</b>
<b>Transport</b>	<b>6,839</b>	<b>7,936</b>	<b>7,819</b>	<b>7,500</b>	<b>6,664</b>	<b>5,886</b>
Oil products	5,993	6,472	5,624	4,411	1,742	256
Natural gas	271	367	646	821	894	663
Biofuels	557	1,056	1,315	1,761	2,317	2,291
Synfuels	0	0	0	0	0	0
Electricity	18	41	198	438	1,169	1,814
RES electricity	12	30	153	368	1,076	1,756
Hydrogen	0	0	36	68	543	863
<b>RES share Transport</b>	<b>8%</b>	<b>14%</b>	<b>19%</b>	<b>29%</b>	<b>58%</b>	<b>83%</b>
<b>Industry</b>	<b>6,962</b>	<b>8,254</b>	<b>7,908</b>	<b>8,138</b>	<b>7,431</b>	<b>6,153</b>
Electricity	1,569	1,903	2,066	2,302	2,683	2,631
RES electricity	1,012	1,356	1,590	1,934	2,468	2,546
Public district heat	1	11	53	55	87	110
RES district heat	1	10	45	45	70	90
Hard coal & lignite	373	611	565	458	27	0
Oil products	1,627	1,326	703	380	30	7
Gas	1,518	1,925	1,684	1,573	988	103
Solar	0	169	278	493	752	647
Biomass	1,874	2,270	2,498	2,740	2,555	2,263
Geothermal	0	39	81	137	328	382
Hydrogen	0	0	0	0	0	10
<b>RES share Industry</b>	<b>41%</b>	<b>47%</b>	<b>57%</b>	<b>66%</b>	<b>83%</b>	<b>97%</b>
<b>Other Sectors</b>	<b>5,198</b>	<b>5,812</b>	<b>5,817</b>			

# LATIN AMERICA: ADVANCED ENERGY [R]EVOLUTION SCENARIO

Table 13.3.15 Latin America: Electricity generation TWh/a

	2012	2020	2025	2030	2040	2050
<b>Power plants</b>	<b>1,152</b>	<b>1,427</b>	<b>1,666</b>	<b>1,974</b>	<b>2,929</b>	<b>3,672</b>
Hard coal (& non-renewable waste)	31	31	23	7	0	0
Lignite	7	7	5	1	0	0
Gas	198	194	183	144	67	22
Oil	0	0	0	0	8	22
of which from H <sup>1</sup>	0	0	0	0	0	0
Diesel	121	89	59	15	4	0
Nuclear	29	25	15	10	1	0
Biomass (& renewable waste)	22	18	11	0	0	0
Hydro	10	45	62	96	154	217
Wind	722	797	799	811	817	820
of which wind offshore	8	130	275	438	940	1,255
PV	0	0	85	148	430	580
Geothermal	4	10	14	17	64	131
Solar thermal power plants	0	17	85	170	376	490
Ocean energy	0	0	10	35	60	90
<b>Combined heat and power plants</b>	<b>63</b>	<b>81</b>	<b>114</b>	<b>160</b>	<b>288</b>	<b>400</b>
Hard coal (& non-renewable waste)	1	0	0	0	0	0
Lignite	0	0	0	0	0	0
Gas	16	21	29	46	93	128
Oil	0	0	0	0	11	128
of which from H <sup>1</sup>	0	0	0	0	0	0
Diesel	6	6	3	0	0	0
Biomass (& renewable waste)	40	54	78	104	146	163
Geothermal	0	1	4	8	41	92
Hydrogen	0	0	0	1	7	18
<b>CHP by producer</b>						
Main activity producers	0	5	13	22	42	47
Autoproducers	63	76	101	138	246	353
<b>Total generation</b>	<b>1,216</b>	<b>1,509</b>	<b>1,780</b>	<b>2,134</b>	<b>3,216</b>	<b>4,072</b>
Fossil	409	374	317	223	146	0
Hard coal (& non-renewable waste)	32	32	23	7	0	0
Lignite	8	7	5	1	0	0
Gas	213	215	212	190	141	0
Oil	127	95	62	15	4	0
Diesel	29	25	15	10	1	0
Nuclear	22	18	11	0	0	0
Hydrogen	0	0	0	1	26	168
of which renewable H <sup>1</sup>	0	0	0	1	25	168
<b>Renewables (w/o renewable hydrogen)</b>	<b>784</b>	<b>1,117</b>	<b>1,452</b>	<b>1,909</b>	<b>3,045</b>	<b>3,904</b>
Hydro	722	797	799	811	817	820
Wind	8	130	275	438	940	1,255
PV	0	65	125	230	446	647
Biomass (& renewable waste)	50	98	140	200	300	380
Geothermal	4	11	18	25	105	222
Solar thermal power plants	0	17	85	170	376	490
Ocean energy	0	0	10	35	60	90
Distribution losses	179	209	220	231	254	280
Own consumption electricity	50	57	58	58	60	61
Electricity for hydrogen production	0	0	64	135	556	1,146
Electricity for synfuel production	0	0	0	0	70	87
<b>Final energy consumption (electricity)</b>	<b>987</b>	<b>1,245</b>	<b>1,441</b>	<b>1,711</b>	<b>2,279</b>	<b>2,500</b>
Fluctuating RES (PV, Wind, Ocean)	8	195	410	703	1,446	1,992
Share of fluctuating RES	1%	13%	23%	33%	45%	49%
<b>RES share (domestic generation)</b>	<b>64%</b>	<b>74%</b>	<b>82%</b>	<b>90%</b>	<b>95%</b>	<b>100%</b>

Table 13.3.16 Latin America: Final energy consumption in transport PJ/a

	2012	2020	2025	2030	2040	2050
<b>Road</b>	<b>6,326</b>	<b>7,052</b>	<b>6,580</b>	<b>5,941</b>	<b>4,409</b>	<b>3,664</b>
Fossil fuels	5,561	5,620	4,426	3,079	669	0
Biofuels	557	992	1,106	1,319	1,163	758
Synfuels	0	0	0	1	81	78
Natural gas	207	273	444	419	146	0
Hydrogen	0	0	156	334	1,070	1,176
Electricity	0	168	448	789	1,361	1,731
<b>Rail</b>	<b>128</b>	<b>163</b>	<b>208</b>	<b>257</b>	<b>415</b>	<b>442</b>
Fossil fuels	109	108	80	49	11	0
Biofuels	0	3	14	16	20	4
Synfuels	0	0	0	0	1	0
Electricity	18	51	114	191	383	437
<b>Navigation</b>	<b>122</b>	<b>164</b>	<b>188</b>	<b>205</b>	<b>258</b>	<b>307</b>
Fossil fuels	122	159	170	154	90	0
Biofuels	0	5	19	51	157	278
Synfuels	0	0	0	0	11	29
<b>Aviation</b>	<b>200</b>	<b>219</b>	<b>223</b>	<b>225</b>	<b>245</b>	<b>253</b>
Fossil fuels	200	213	201	168	86	0
Biofuels	0	7	22	56	149	229
Synfuels	0	0	0	0	10	24
<b>Total (incl. pipelines)</b>	<b>6,839</b>	<b>7,673</b>	<b>7,270</b>	<b>6,694</b>	<b>5,461</b>	<b>4,744</b>
Fossil fuels	5,993	6,100	4,876	3,451	857	0
Biofuels (incl. biogas)	557	1,007	1,162	1,443	1,488	1,269
Synfuels	0	0	0	1	103	131
Natural gas	271	346	513	483	191	0
Hydrogen	0	0	156	334	1,070	1,176
Electricity	18	219	563	983	1,753	2,168
<b>Total RES</b>	<b>569</b>	<b>1,169</b>	<b>1,748</b>	<b>2,622</b>	<b>4,280</b>	<b>4,744</b>
<b>RES share</b>	<b>8%</b>	<b>15%</b>	<b>24%</b>	<b>39%</b>	<b>78%</b>	<b>100%</b>

Table 13.3.17 Latin America: Heat supply PJ/a

	2012	2020	2025	2030	2040	2050
<b>District heating plants</b>	<b>0</b>	<b>3</b>	<b>9</b>	<b>22</b>	<b>79</b>	<b>109</b>
Fossil fuels	0	0	1	2	2	0
Biomass	0	2	6	15	50	49
Solar collectors	0	0	1	3	16	38
Geothermal	0	0	1	2	12	22
<b>Heat from CHP<sup>1</sup></b>	<b>134</b>	<b>227</b>	<b>385</b>	<b>602</b>	<b>1,388</b>	<b>2,539</b>
Fossil fuels	60	78	104	155	288	0
Biomass	74	141	248	370	663	1,173
Geothermal	0	8	32	70	357	799
Hydrogen	0	0	1	7	80	567
<b>Direct heating</b>	<b>7,354</b>	<b>8,536</b>	<b>8,145</b>	<b>8,337</b>	<b>7,923</b>	<b>6,653</b>
Fossil fuels	4,221	4,560	3,549	3,005	1,234	0
Biomass	2,241	2,589	2,825	2,980	2,767	2,386
Solar collectors	22	301	514	825	1,364	1,356
Geothermal	0	6	26	55	150	176
Heat pumps <sup>2</sup>	0	76	118	169	352	490
Electric direct heating	870	1,005	1,112	1,304	1,905	1,767
Hydrogen	0	0	0	0	150	477
<b>Total heat supply<sup>3</sup></b>	<b>7,487</b>	<b>8,766</b>	<b>8,538</b>	<b>8,961</b>	<b>9,390</b>	<b>9,301</b>
Fossil fuels	4,281	4,638	3,654	3,162	1,524	0
Biomass	2,314	2,732	3,079	3,365	3,479	3,608
Solar collectors	22	301	515	828	1,380	1,394
Geothermal	0	14	59	127	520	997
Heat pumps <sup>2</sup>	0	76	118	169	352	490
Electric direct heating	870	1,005	1,112	1,304	1,905	1,767
Hydrogen	0	0	1	7	230	1,045
<b>RES share (including RES electricity)</b>	<b>39%</b>	<b>44%</b>	<b>55%</b>	<b>63%</b>	<b>83%</b>	<b>100%</b>

<sup>1</sup> public CHP and CHP autoproduction / <sup>2</sup> heat from ambient energy and electricity use / <sup>3</sup> incl. process heat, cooking

Table 13.3.18: Latin America: Installed capacity GW

	2012	2020	2025	2030	2040	2050
<b>Total generation</b>	<b>272</b>	<b>408</b>	<b>517</b>	<b>658</b>	<b>1,039</b>	<b>1,310</b>
<b>Fossil</b>	<b>103</b>	<b>119</b>	<b>115</b>	<b>89</b>	<b>77</b>	<b>0</b>
Hard coal (& non-renewable waste)	6	6	5	2	0	0
Lignite	2	1	1	0	0	0
Gas (w/o H <sup>1</sup> )	54	71	81	78	75	0
Oil	8	9	5	6	0	0
Diesel	3	2	2	4	0	0
Nuclear	0	0	0	0	0	0
Hydrogen (fuel cells, gas power plants, gas CHP)	0	0	0	0	12	80
<b>Renewables</b>	<b>166</b>	<b>286</b>	<b>401</b>	<b>569</b>	<b>950</b>	<b>1,230</b>
Hydro	148	164	165	167	168	169
Wind	4	41	82	128	200	344
of which wind offshore	0	8	21	36	102	137
PV	0	51	94	170	325	461
Biomass (& renewable waste)	14	23	32	45	73	105
Geothermal	1	2	3	4	15	32
Solar thermal power plants	0	6	23	45	93	94
Ocean energy	0	0	3	10	17	25
Fluctuating RES (PV, Wind, Ocean)	4	91	179	308	600	830
Share of fluctuating RES	1%	22%	35%	47%	58%	63%
<b>RES share (domestic generation)</b>	<b>61%</b>	<b>70%</b>	<b>77%</b>	<b>86%</b>	<b>91%</b>	<b>94%</b>

Table 13.3.19: Latin America: Final energy demand PJ/a

	2012	2020	2025	2030	2040	2050
<b>Total (incl. non-energy use)</b>	<b>20,497</b>	<b>23,295</b>	<b>22,521</b>	<b>22,290</b>	<b>20,556</b>	<b>18,623</b>
<b>Total energy use</b>	<b>18,999</b>	<b>21,738</b>	<b>20,995</b>	<b>20,780</b>	<b>19,077</b>	<b>17,144</b>
<b>Transport</b>	<b>6,839</b>	<b>7,673</b>	<b>7,270</b>	<b>6,694</b>	<b>5,461</b>	<b>4,744</b>
Oil products	5,993	6,100	4,876	3,451	857	0
Natural gas	271	346	513	483	191	0
Biofuels	557	1,007	1,162	1,443	1,488	1,269
Synfuels	0	0	0	1	103	131
Electricity	18	219	563	983	1,753	2,168
RES electricity	12	162	459	880	1,673	2,168
Hydrogen	0	0	156	334	1,070	1,176
<b>RES share Transport</b>	<b>8%</b>	<b>15%</b>	<b>24%</b>	<b>39%</b>	<b>78%</b>	<b>100%</b>
<b>Industry</b>	<b>6,962</b>	<b>8,254</b>	<b>7,908</b>	<b>8,183</b>	<b>7,541</b>	<b>6,331</b>
Electricity	1,599	1,903	2,066	2,365	2,947	2,903
RES electricity	1,012	1,409	1,685	2,117	2,813	2,903
Public district heat	1	11	53	55	87	110
RES district heat	1	11	45	45	69	110
Hard coal & lignite	373	611	565	458	27	0
Oil products	1,627	1,326	703	369	12	0
Gas	1,518	1,925	1,684	1,566	735	0
Solar	0	169	278	493	752	647
Biomass	1,874	2,270	2,498	2,740	2,555	2,240
Geothermal	0	39	81	137	328	382
Hydrogen	0	0	0	0	98	50
<b>RES share Industry</b>	<b>41%</b>	<b>47%</b>	<b>58%</b>	<b>68%</b>	<b>88%</b>	<b>100%</b>
<b>Other</b>						

Table 13.3.22: Latin America: Investments in electricity generation

REF	UNIT	2012-2020	2021-2030	2031-2040	2041-2050	2012-2050	UNIT	ANNUAL AVERAGE 2012-2050
3 Fossil (w/o CHP)	billion \$	53.9	52.7	83.2	115.7	305.5	billion \$/a	7.8
Nuclear	billion \$	8.3	9.2	7.8	11.3	36.7	billion \$/a	0.9
CHP (fossil + renewable)	billion \$	22.3	27.8	11.8	6.2	68.0	billion \$/a	1.7
Renewables (w/o CHP)	billion \$	226.9	265.2	276.6	219.1	987.8	billion \$/a	25.3
<b>Total</b>	<b>billion \$</b>	<b>311.4</b>	<b>354.8</b>	<b>379.4</b>	<b>352.4</b>	<b>1,398.0</b>	<b>billion \$/a</b>	<b>35.8</b>
Conventional (fossil & nuclear)	billion \$	75.0	70.4	94.3	128.5	368.3	billion \$/a	9.4
Renewables	billion \$	236.4	284.4	285.1	223.9	1,029.8	billion \$/a	26.4
Biomass	billion \$	18.7	31.3	24.8	19.4	94.3	billion \$/a	2.4
Hydro	billion \$	181.8	205.3	192.5	128.5	708.1	billion \$/a	18.2
Wind	billion \$	21.0	26.0	36.6	42.9	126.5	billion \$/a	3.2
PV	billion \$	8.2	8.4	11.0	11.8	39.5	billion \$/a	1.0
Geothermal	billion \$	6.6	8.3	9.2	7.0	31.2	billion \$/a	0.8
Solar thermal power plants	billion \$	0.0	5.0	10.4	13.7	29.2	billion \$/a	0.7
Ocean energy	billion \$	0.0	0.0	0.5	0.6	1.0	billion \$/a	0.0
<b>E[R]</b>								
Fossil (w/o CHP)	billion \$	41.0	21.4	36.6	46.9	145.8	billion \$/a	3.7
Nuclear	billion \$	3.4	0.0	0.0	0.0	3.4	billion \$/a	0.1
CHP (fossil + renewable)	billion \$	51.3	90.3	98.7	86.5	326.9	billion \$/a	8.4
Renewables (w/o CHP)	billion \$	242.1	454.3	746.1	687.1	2,129.5	billion \$/a	54.6
<b>Total</b>	<b>billion \$</b>	<b>337.8</b>	<b>566.0</b>	<b>881.3</b>	<b>820.5</b>	<b>2,605.6</b>	<b>billion \$/a</b>	<b>66.8</b>
Conventional (fossil & nuclear)	billion \$	71.7	53.8	77.2	76.8	279.4	billion \$/a	7.2
Renewables	billion \$	266.1	512.2	804.2	743.7	2,326.2	billion \$/a	59.6
Biomass	billion \$	34.3	76.4	99.1	124.8	334.7	billion \$/a	8.6
Hydro	billion \$	105.7	66.2	69.1	70.3	311.4	billion \$/a	8.0
Wind	billion \$	48.9	119.8	199.6	236.8	605.1	billion \$/a	15.5
PV	billion \$	61.4	100.7	153.4	135.8	451.2	billion \$/a	11.6
Geothermal	billion \$	12.5	12.0	24.9	23.5	72.9	billion \$/a	1.9
Solar thermal power plants	billion \$	3.4	134.4	240.3	140.0	518.1	billion \$/a	13.3
Ocean energy	billion \$	0.0	2.6	17.7	12.5	32.8	billion \$/a	0.8
<b>ADV E[R]</b>								
Fossil (w/o CHP)	billion \$	37.3	11.9	32.0	14.1	95.3	billion \$/a	2.4
Nuclear	billion \$	3.4	0.0	0.0	0.0	3.4	billion \$/a	0.1
CHP (fossil + renewable)	billion \$	31.6	84.1	75.0	73.1	263.8	billion \$/a	6.8
Renewables (w/o CHP)	billion \$	337.6	745.0	1,054.8	895.5	3,033.0	billion \$/a	77.8
<b>Total</b>	<b>billion \$</b>	<b>410.0</b>	<b>840.9</b>	<b>1,161.9</b>	<b>982.7</b>	<b>3,395.5</b>	<b>billion \$/a</b>	<b>87.1</b>
Conventional (fossil & nuclear)	billion \$	57.6	40.6	62.3	33.9	194.4	billion \$/a	5.0
Renewables	billion \$	352.4	800.3	1,099.6	948.8	3,201.2	billion \$/a	82.1
Biomass	billion \$	32.8	80.9	95.4	130.4	339.4	billion \$/a	8.7
Hydro	billion \$	105.7	69.2	67.8	68.4	311.2	billion \$/a	8.0
Wind	billion \$	77.4	190.1	367.2	322.9	957.5	billion \$/a	24.6
PV	billion \$	88.2	155.8	208.3	199.8	652.1	billion \$/a	16.7
Geothermal	billion \$	12.5	12.0	52.7	65.9	143.0	billion \$/a	3.7
Solar thermal power plants	billion \$	35.9	241.9	285.0	135.1	697.9	billion \$/a	17.9
Ocean energy	billion \$	0.0	50.4	23.2	26.3	99.9	billion \$/a	2.6

Table 13.3.23: Latin America: Investments in renewable heat generation

REF	UNIT	2012-2020	2021-2030	2031-2040	2041-2050	2012-2050	UNIT	ANNUAL AVERAGE 2012-2050
Heat pumps	billion \$	0.0	0.0	0.0	0.0	0.0	billion \$/a	0.0
Deep geothermal	billion \$	0.0	0.0	0.0	0.0	0.0	billion \$/a	0.0
Solar thermal	billion \$	3.0	3.0	6.4	6.6	19.1	billion \$/a	0.5
Biomass	billion \$	74.4	96.8	37.4	27.9	236.4	billion \$/a	6.1
<b>Total</b>	<b>billion \$</b>	<b>77.4</b>	<b>99.8</b>	<b>43.8</b>	<b>34.5</b>	<b>255.5</b>	<b>billion \$/a</b>	<b>6.6</b>
<b>E[R]</b>								
Heat pumps	billion \$	17.4	19.3	51.7	51.9	140.4	billion \$/a	3.6
Deep geothermal	billion \$	1.4	10.1	23.9	13.9	49.3	billion \$/a	1.3
Solar thermal	billion \$	40.1	68.1	88.9	13.4	210.4	billion \$/a	5.4
Biomass	billion \$	92.3	85.9	2.1	0.5	180.8	billion \$/a	4.6
<b>Total</b>	<b>billion \$</b>	<b>151.3</b>	<b>183.4</b>	<b>166.5</b>	<b>79.6</b>	<b>580.9</b>	<b>billion \$/a</b>	<b>14.9</b>
<b>ADV E[R]</b>								
Heat pumps	billion \$	17.4	19.3	51.7	51.8	140.2	billion \$/a	3.6
Deep geothermal	billion \$	1.4	10.1	23.9	13.8	49.3	billion \$/a	1.3
Solar thermal	billion \$	40.1	68.1	88.9	13.3	210.4	billion \$/a	5.4
Biomass	billion \$	92.3	85.9	2.1	0.5	180.8	billion \$/a	4.6
<b>Total</b>	<b>billion \$</b>	<b>151.3</b>	<b>183.4</b>	<b>166.6</b>	<b>79.3</b>	<b>580.7</b>	<b>billion \$/a</b>	<b>14.9</b>

Table 13.3.24: Latin America: Total employment in the energy sector THOUSAND JOBS

By sector	REFERENCE SCENARIO				ADV E[R] SCENARIO		
	2015	2020	2025	2030	2020	2025	2030
Construction and installation	224	210	206	180	485	687	769
Manufacturing	99	96	97	89	230	361	552
Operations and maintenance	284	319	351	372	434	572	717
Fuel supply (domestic)	790	890	987	1,057	891	920	962
Coal and gas export	45.9	54.0	58.9	62.6	32.6	21.9	11.3
Solar and geothermal heat	29	29	27	24	438	321	411
<b>Total jobs (thousands)</b>	<b>1,472</b>	<b>1,597</b>	<b>1,727</b>	<b>1,784</b>	<b>2,510</b>	<b>2,884</b>	<b>3,423</b>
<b>By technology</b>							
Coal	88	81	89	109	34	27	13
Gas, oil & diesel	418	483	530	544	422	367	312
Nuclear	9	10	10	11	4	5	7
<b>Renewable</b>	<b>958</b>	<b>1,024</b>	<b>1,098</b>	<b>1,120</b>	<b>2,050</b>	<b>2,485</b>	<b>3,092</b>
Biomass	584	629	678	718	766	899	998
Hydro	299	303	320	303	103	122	113
Wind	19	25	31	32	207	267	511
PV	26	33	35	33	414	651	750
Geothermal power	2.3	3.0	2.9	2.8	6.2	7.5	20.8
Solar thermal power	0.3	1.6	3.2	6.1	84	165	254
Ocean	-	1	0	1	32.6	52.6	33
Solar - heat	28.9	28.8	27.3	24.2	388	289	375
Geothermal & heat pump	-	-	-	-	49	33	36
<b>Total jobs (thousands)</b>	<b>1,472</b>	<b>1,597</b>	<b>1,727</b>	<b>1,784</b>	<b>2,510</b>	<b>2,884</b>	<b>3,423</b>

# OECD EUROPE: REFERENCE SCENARIO

Table 13.4.1 OECD Europe: Electricity generation TWh/a

	2012	2020	2025	2030	2040	2050
<b>Power plants</b>	<b>2,928</b>	<b>3,237</b>	<b>3,444</b>	<b>3,650</b>	<b>4,091</b>	<b>4,414</b>
Hard coal (& non-renewable waste)	454	415	409	406	441	488
Lignite	256	249	241	232	217	181
Gas	400	475	651	823	1,073	1,212
<i>of which from H<sup>1</sup></i>	0	0	0	0	0	0
Oil	35	12	8	6	5	2
Diesel	8	7	7	7	6	6
Nuclear	869	852	772	692	649	606
Biomass (& renewable waste)	55	83	89	96	108	117
Hydro	562	591	607	624	646	669
Wind	208	407	493	580	704	828
<i>of which wind offshore</i>	18	49	75	101	152	203
Geothermal	67	124	135	146	163	182
Solar thermal power plants	4	10	14	18	22	25
Ocean energy	0	1	3	5	26	48
<b>Combined heat and power plants</b>	<b>674</b>	<b>697</b>	<b>707</b>	<b>717</b>	<b>731</b>	<b>746</b>
Hard coal (& non-renewable waste)	148	137	136	131	122	103
Lignite	90	87	86	84	79	75
Gas	306	326	330	339	355	375
<i>of which from H<sup>1</sup></i>	0	0	0	0	0	0
Oil	33	19	14	7	2	0
Biomass (& renewable waste)	96	126	139	152	168	186
Geothermal	2	2	3	3	4	6
Hydrogen	0	0	0	0	0	0
<b>CHP by producer</b>						
Main activity producers	477	496	504	511	522	532
Autoproducers	197	201	203	205	209	214
<b>Total generation</b>	<b>3,602</b>	<b>3,935</b>	<b>4,151</b>	<b>4,366</b>	<b>4,822</b>	<b>5,160</b>
Fossil	1,729	1,727	1,881	2,035	2,301	2,443
Hard coal (& non-renewable waste)	601	552	544	537	564	591
Lignite	346	336	326	316	296	256
Gas	706	800	981	1,162	1,428	1,587
Oil	68	31	22	13	7	2
Diesel	8	7	7	7	6	6
Nuclear	869	852	772	692	649	606
Hydrogen	0	0	0	0	0	0
<i>of which renewable H<sup>1</sup></i>	0	0	0	0	0	0
<b>Renewables (w/o renewable hydrogen)</b>	<b>1,004</b>	<b>1,356</b>	<b>1,498</b>	<b>1,639</b>	<b>1,872</b>	<b>2,111</b>
Hydro	562	591	607	624	646	669
Wind	208	407	493	580	704	828
PV	67	124	135	146	163	182
Biomass (& renewable waste)	151	209	228	248	275	303
Geothermal	12	15	17	19	25	31
Solar thermal power plants	4	10	14	18	22	25
Ocean energy	0	1	3	5	26	48
Distribution losses	248	275	292	308	341	366
Own consumption electricity	281	245	244	242	253	263
Electricity for hydrogen production	0	0	0	0	0	0
Electricity for synfuel production	0	0	0	0	0	0
<b>Final energy consumption (electricity)</b>	<b>3,067</b>	<b>3,401</b>	<b>3,601</b>	<b>3,802</b>	<b>4,212</b>	<b>4,515</b>
Fluctuating RES (PV, Wind, Ocean)	275	532	631	731	894	1,059
Share of fluctuating RES	8%	14%	15%	17%	19%	21%
<b>RES share (domestic generation)</b>	<b>28%</b>	<b>34%</b>	<b>36%</b>	<b>38%</b>	<b>39%</b>	<b>41%</b>

Table 13.4.2 OECD Europe: Final energy consumption in transport PJ/a

	2012	2020	2025	2030	2040	2050
<b>Road</b>	<b>12,527</b>	<b>12,572</b>	<b>12,545</b>	<b>12,557</b>	<b>11,937</b>	<b>11,328</b>
Fossil fuels	11,864	11,705	11,513	11,360	10,340	9,530
Biofuels	606	747	858	971	1,234	1,268
Synfuels	0	0	0	0	0	0
Natural gas	56	92	116	140	202	277
Hydrogen	0	0	0	0	0	0
Electricity	2	28	57	86	161	253
<b>Rail</b>	<b>387</b>	<b>401</b>	<b>409</b>	<b>417</b>	<b>430</b>	<b>442</b>
Fossil fuels	149	149	149	149	149	149
Biofuels	0	0	0	0	0	0
Synfuels	0	0	0	0	0	0
Electricity	238	253	260	268	282	293
<b>Navigation</b>	<b>238</b>	<b>300</b>	<b>331</b>	<b>331</b>	<b>338</b>	<b>341</b>
Fossil fuels	238	300	331	331	338	341
Biofuels	0	0	0	0	0	0
Synfuels	0	0	0	0	0	0
<b>Aviation</b>	<b>262</b>	<b>400</b>	<b>450</b>	<b>491</b>	<b>507</b>	<b>518</b>
Fossil fuels	262	400	450	491	507	518
Biofuels	0	0	0	0	0	0
Synfuels	0	0	0	0	0	0
<b>Total (incl. pipelines)</b>	<b>13,467</b>	<b>13,731</b>	<b>13,794</b>	<b>13,858</b>	<b>13,279</b>	<b>12,699</b>
Fossil fuels	12,512	12,554	12,443	12,331	11,334	10,538
Biofuels (incl. biogas)	606	747	858	971	1,234	1,268
Synfuels	0	0	0	0	0	0
Natural gas	109	149	176	202	267	347
Hydrogen	0	0	0	0	0	0
Electricity	240	281	318	354	443	546
<b>Total RES</b>	<b>672</b>	<b>844</b>	<b>972</b>	<b>1,104</b>	<b>1,406</b>	<b>1,491</b>
<b>RES share</b>	<b>5%</b>	<b>6%</b>	<b>7%</b>	<b>8%</b>	<b>11%</b>	<b>12%</b>

Table 13.4.3 OECD Europe: Heat supply PJ/a

	2012	2020	2025	2030	2040	2050
<b>District heating plants</b>	<b>641</b>	<b>643</b>	<b>656</b>	<b>667</b>	<b>707</b>	<b>670</b>
Fossil fuels	486	467	466	464	467	416
Biomass	149	163	172	182	207	209
Solar collectors	0	1	1	2	5	11
Geothermal	6	12	16	20	28	33
<b>Heat from CHP<sup>1</sup></b>	<b>1,696</b>	<b>1,882</b>	<b>2,029</b>	<b>2,187</b>	<b>2,580</b>	<b>3,324</b>
Fossil fuels	1,364	1,406	1,473	1,541	1,762	2,176
Biomass	322	460	537	624	787	1,108
Geothermal	10	15	19	23	31	40
Hydrogen	0	0	0	0	0	0
<b>Direct heating</b>	<b>19,089</b>	<b>20,370</b>	<b>20,815</b>	<b>21,269</b>	<b>22,093</b>	<b>22,979</b>
Fossil fuels	14,447	15,122	15,255	15,393	15,514	15,645
Biomass	1,916	2,266	2,458	2,635	3,013	3,400
Solar collectors	107	210	279	349	495	674
Geothermal	0	0	0	0	0	0
Heat pumps <sup>2</sup>	163	230	266	301	408	546
Electric direct heating	2,457	2,523	2,557	2,592	2,663	2,714
Hydrogen	0	0	0	0	0	0
<b>Total heat supply<sup>3</sup></b>	<b>21,425</b>	<b>22,895</b>	<b>23,500</b>	<b>24,124</b>	<b>25,380</b>	<b>26,973</b>
Fossil fuels	16,296	16,996	17,194	17,397	17,743	18,237
Biomass	2,387	2,908	3,167	3,441	4,007	4,717
Solar collectors	107	211	281	351	500	685
Geothermal	15	28	35	43	59	74
Heat pumps <sup>2</sup>	163	230	266	301	408	546
Electric direct heating	2,457	2,523	2,557	2,592	2,663	2,714
Hydrogen	0	0	0	0	0	0
<b>RES share (including RES electricity)</b>	<b>16%</b>	<b>19%</b>	<b>20%</b>	<b>21%</b>	<b>24%</b>	<b>27%</b>

<sup>1</sup> public CHP and CHP autoproduction / <sup>2</sup> heat from ambient energy and electricity use / <sup>3</sup> incl. process heat, cooking

Table 13.4.4: OECD Europe: Installed capacity GW

	2012	2020	2025	2030	2040	2050
<b>Total generation</b>	<b>1,020</b>	<b>1,202</b>	<b>1,268</b>	<b>1,334</b>	<b>1,454</b>	<b>1,529</b>
<b>Fossil</b>	<b>483</b>	<b>525</b>	<b>555</b>	<b>584</b>	<b>637</b>	<b>642</b>
Hard coal (& non-renewable waste)	117	114	108	102	102	102
Lignite	67	69	65	60	54	44
Gas (w/o H <sup>1</sup> )	240	305	353	402	466	486
Oil	53	30	21	13	8	3
Diesel	6	7	7	7	7	7
Nuclear	127	123	111	99	91	85
Hydrogen (fuel cells, gas power plants, gas CHP)	0	0	0	0	0	0
<b>Renewables</b>	<b>409</b>	<b>553</b>	<b>602</b>	<b>651</b>	<b>727</b>	<b>803</b>
Hydro	202	214	220	225	232	240
Wind	0	176	205	235	273	310
<i>of which wind offshore</i>	5	14	21	28	41	53
Biomass (& renewable waste)	68	113	123	132	145	156
Geothermal	33	44	46	49	53	59
Solar thermal power plants	2	3	4	5	9	14
Ocean energy	0	0	1	2	11	19
Fluctuating RES (PV, Wind, Ocean)	170	290	330	369	429	485
Share of fluctuating RES	17%	24%	26%	28%	29%	32%
<b>RES share (domestic generation)</b>	<b>40%</b>	<b>46%</b>	<b>47%</b>	<b>49%</b>	<b>50%</b>	<b>52%</b>

Table 13.4.5: OECD Europe: Final energy demand PJ/a

	2012	2020	2025	2030	2040	2050
<b>Total (incl. non-energy use)</b>	<b>50,988</b>	<b>53,477</b>	<b>54,372</b>	<b>55,268</b>	<b>56,140</b>	<b>56,709</b>
<b>Total energy use</b>	<b>46,619</b>	<b>49,210</b>	<b>50,247</b>	<b>51,284</b>	<b>52,544</b>	<b>53,500</b>
<b>Transport</b>	<b>13,467</b>	<b>13,731</b>	<b>13,794</b>	<b>13,858</b>	<b>13,279</b>	<b>12,699</b>
Oil products	12,512	12,554	12,443	12,331	11,334	10,538
Natural gas	109	149	176	202	267	347
Biofuels	606	747	858	971	1,234	1,268
Synfuels	0	0	0	0	0	0
Electricity	240	281	318	354	443	546
RES electricity	67	97	115	133	172	223
Hydrogen	0	0	0	0	0	0
<b>RES share Transport</b>	<b>5%</b>	<b>6%</b>	<b>7%</b>	<b>8%</b>	<b>11%</b>	<b>12%</b>
<b>Industry</b>	<b>12,059</b>	<b>12,388</b>	<b>12,331</b>	<b>12,274</b>	<b>11,996</b>	<b>11,547</b>
Electricity	4,030	4,439	4,543	4,648	4,806	4,945
RES electricity	1,140	1,530	1,640	1,745	1,866	2,023
Public district heat	677	685	671	657	625	576
RES district heat	68	175	186	195	199	190
Hard coal & lignite	1,237	1,246	1,189	1,131	1,005	820
Oil products	1,375	1,261	1,170	1,078	898	724
Gas	3,900	3,743	3,650	3,556	3,350	3,091
Solar	12	15	18	20	31	42
Biomass	767	997	1,089	1,180	1,280	1,346
Geothermal	2	2	2	2	2	3
Hydrogen	0	0	0	0	0	0
<b>RES share Industry</b>	<b></b>					



**Table 13.4.8 OECD Europe: Electricity generation TWh/a**

	2012	2020	2025	2030	2040	2050
<b>Power plants</b>	<b>2,928</b>	<b>2,999</b>	<b>2,954</b>	<b>3,004</b>	<b>3,384</b>	<b>3,694</b>
Hard coal (& non-renewable waste)	454	327	251	216	44	4
Lignite	256	183	59	22	0	0
Gas	400	540	554	554	343	56
<i>of which from H<sub>2</sub></i>	0	0	0	0	0	0
Oil	35	3	0	0	0	0
Diesel	8	7	6	5	3	1
Nuclear	869	560	360	80	0	0
Biomass (& renewable waste)	55	100	102	100	90	79
Hydro	562	591	596	600	610	620
Wind	208	479	682	915	1,349	1,592
<i>of which wind offshore</i>	18	58	121	211	431	563
PV	67	183	276	376	577	723
Geothermal	10	12	24	39	70	161
Solar thermal power plants	4	12	31	68	208	327
Ocean energy	0	2	12	30	90	130
<b>Combined heat and power plants</b>	<b>674</b>	<b>721</b>	<b>763</b>	<b>805</b>	<b>790</b>	<b>710</b>
Hard coal (& non-renewable waste)	148	104	64	36	0	0
Lignite	90	67	26	3	0	0
Gas	306	350	371	376	307	183
<i>of which from H<sub>2</sub></i>	0	0	0	0	9	26
Oil	33	24	7	0	0	0
Biomass (& renewable waste)	96	171	278	351	366	351
Geothermal	2	5	15	39	111	149
Hydrogen	0	0	0	0	6	27
<b>CHP by producer</b>						
Main activity producers	477	510	525	540	515	460
Autoproducers	197	211	238	265	275	250
<b>Total generation</b>	<b>3,602</b>	<b>3,720</b>	<b>3,716</b>	<b>3,809</b>	<b>4,174</b>	<b>4,404</b>
Fossil	1,729	1,605	1,339	1,212	688	219
Hard coal (& non-renewable waste)	601	431	315	252	44	4
Lignite	346	250	85	25	0	0
Gas	706	890	925	930	641	214
Oil	68	27	8	0	0	0
Diesel	8	7	6	5	3	1
Nuclear	869	560	360	80	0	0
Hydrogen	0	0	0	0	15	53
<i>of which renewable H<sub>2</sub></i>	0	0	0	0	13	50
<b>Renewables (w/o renewable hydrogen)</b>	<b>1,004</b>	<b>1,555</b>	<b>2,017</b>	<b>2,517</b>	<b>3,470</b>	<b>4,132</b>
Hydro	562	591	596	600	610	620
Wind	208	479	682	915	1,349	1,592
PV	67	183	276	376	577	723
Biomass (& renewable waste)	151	272	380	451	456	430
Geothermal	12	17	39	77	180	309
Solar thermal power plants	4	12	31	68	208	327
Ocean energy	0	2	12	30	90	130
Distribution losses	248	255	245	240	230	230
Own consumption electricity	281	240	228	217	173	134
Electricity for hydrogen production	0	2	35	146	606	1,016
Electricity for synfuel production	0	0	0	0	0	0
<b>Final energy consumption (electricity)</b>	<b>3,067</b>	<b>3,238</b>	<b>3,252</b>	<b>3,340</b>	<b>3,465</b>	<b>3,424</b>
Fluctuating RES (PV, Wind, Ocean)	275	664	970	1,321	2,016	2,446
Share of fluctuating RES	8%	18%	26%	35%	48%	56%
<b>RES share (domestic generation)</b>	<b>28%</b>	<b>42%</b>	<b>54%</b>	<b>66%</b>	<b>83%</b>	<b>95%</b>

**Table 13.4.9 OECD Europe: Final energy consumption in transport PJ/a**

	2012	2020	2025	2030	2040	2050
<b>Road</b>	<b>12,527</b>	<b>11,069</b>	<b>9,519</b>	<b>8,157</b>	<b>5,690</b>	<b>4,925</b>
Fossil fuels	11,864	10,221	8,405	6,376	2,025	554
Biofuels	606	618	584	517	415	321
Synfuels	0	0	0	0	0	0
Natural gas	56	111	143	150	164	177
Hydrogen	0	5	86	370	1,389	1,885
Electricity	2	114	301	744	1,697	1,987
<b>Rail</b>	<b>387</b>	<b>407</b>	<b>412</b>	<b>417</b>	<b>434</b>	<b>446</b>
Fossil fuels	149	133	114	81	48	19
Biofuels	0	7	6	19	19	10
Synfuels	0	0	0	0	0	0
Electricity	238	267	292	317	367	417
<b>Navigation</b>	<b>238</b>	<b>290</b>	<b>284</b>	<b>265</b>	<b>247</b>	<b>240</b>
Fossil fuels	238	276	269	241	198	156
Biofuels	0	15	14	24	49	84
Synfuels	0	0	0	0	0	0
<b>Aviation</b>	<b>262</b>	<b>380</b>	<b>400</b>	<b>410</b>	<b>390</b>	<b>370</b>
Fossil fuels	262	380	389	385	312	240
Biofuels	0	0	11	25	78	130
Synfuels	0	0	0	0	0	0
<b>Total (incl. pipelines)</b>	<b>13,467</b>	<b>12,196</b>	<b>10,660</b>	<b>9,289</b>	<b>6,792</b>	<b>6,000</b>
Fossil fuels	12,512	11,009	9,177	7,084	2,583	969
Biofuels (incl. biogas)	606	639	616	585	561	544
Synfuels	0	0	0	0	0	0
Natural gas	109	161	187	189	189	186
Hydrogen	0	5	86	370	1,389	1,885
Electricity	240	381	594	1,062	2,070	2,415
<b>Total RES</b>	<b>672</b>	<b>801</b>	<b>985</b>	<b>1,531</b>	<b>3,448</b>	<b>4,628</b>
<b>RES share</b>	<b>5%</b>	<b>7%</b>	<b>9%</b>	<b>16%</b>	<b>51%</b>	<b>77%</b>

**Table 13.4.10 OECD Europe: Heat supply PJ/a**

	2012	2020	2025	2030	2040	2050
<b>District heating plants</b>	<b>641</b>	<b>645</b>	<b>807</b>	<b>859</b>	<b>1,244</b>	<b>1,464</b>
Fossil fuels	486	429	337	262	119	59
Biomass	149	190	242	245	261	249
Solar collectors	0	6	145	219	585	849
Geothermal	6	19	83	133	279	307
<b>Heat from CHP<sup>1</sup></b>	<b>1,696</b>	<b>1,962</b>	<b>2,370</b>	<b>2,756</b>	<b>3,358</b>	<b>3,885</b>
Fossil fuels	1,364	1,311	1,176	1,049	801	519
Biomass	322	618	1,087	1,426	1,645	1,934
Geothermal	10	33	107	278	837	1,156
Hydrogen	0	0	0	3	75	276
<b>Direct heating</b>	<b>19,089</b>	<b>18,537</b>	<b>17,477</b>	<b>16,505</b>	<b>14,684</b>	<b>12,797</b>
Fossil fuels	14,447	13,132	11,044	8,984	5,139	1,919
Biomass	1,916	2,128	2,119	2,041	1,864	1,691
Solar collectors	107	355	1,004	1,597	2,476	2,963
Geothermal	0	0	0	0	0	0
Heat pumps <sup>2</sup>	163	435	840	1,459	2,902	3,617
Electric direct heating	2,457	2,487	2,471	2,424	2,247	2,256
Hydrogen	0	0	0	0	58	351
<b>Total heat supply<sup>3</sup></b>	<b>21,425</b>	<b>21,144</b>	<b>20,654</b>	<b>20,120</b>	<b>19,287</b>	<b>18,145</b>
Fossil fuels	16,296	14,872	12,556	10,295	6,059	2,496
Biomass	2,387	2,937	3,448	3,712	3,770	3,874
Solar collectors	107	362	1,149	1,816	3,061	3,811
Geothermal	15	52	190	411	1,116	1,463
Heat pumps <sup>2</sup>	163	435	840	1,459	2,902	3,617
Electric direct heating	2,457	2,487	2,471	2,424	2,247	2,256
Hydrogen	0	0	0	3	132	627
<b>RES share (including RES electricity)</b>	<b>16%</b>	<b>23%</b>	<b>34%</b>	<b>45%</b>	<b>67%</b>	<b>86%</b>

<sup>1</sup> public CHP and CHP autoproduction / <sup>2</sup> heat from ambient energy and electricity use / <sup>3</sup> incl. process heat, cooking

**Table 13.4.10: OECD Europe: Installed capacity GW**

	2012	2020	2025	2030	2040	2050
<b>Total generation</b>	<b>1,020</b>	<b>1,220</b>	<b>1,288</b>	<b>1,434</b>	<b>1,731</b>	<b>1,848</b>
<b>Fossil</b>	<b>483</b>	<b>487</b>	<b>392</b>	<b>369</b>	<b>293</b>	<b>164</b>
Hard coal (& non-renewable waste)	117	69	63	50	9	1
Lignite	67	51	17	5	0	0
Gas (w/o H <sub>2</sub> )	240	313	299	309	281	162
Oil	53	26	7	0	0	0
Diesel	6	7	6	5	3	1
Nuclear	127	81	52	11	0	0
Hydrogen (fuel cells, gas power plants, gas CHP)	0	0	0	0	6	20
<b>Renewables</b>	<b>409</b>	<b>653</b>	<b>844</b>	<b>1,053</b>	<b>1,432</b>	<b>1,664</b>
Hydro	202	214	216	216	219	223
Wind	102	207	281	363	502	570
<i>of which wind offshore</i>	5	16	34	59	117	148
PV	68	168	252	341	513	620
Biomass (& renewable waste)	33	57	77	95	97	100
Geothermal	2	2	5	10	24	41
Solar thermal power plants	2	4	8	16	43	65
Ocean energy	0	1	5	12	34	45
Fluctuating RES (PV, Wind, Ocean)	170	376	538	716	1,049	1,235
Share of fluctuating RES	17%	31%	42%	50%	61%	67%
<b>RES share (domestic generation)</b>	<b>40%</b>	<b>53%</b>	<b>66%</b>	<b>73%</b>	<b>83%</b>	<b>90%</b>

**Table 13.4.12: OECD Europe: Final energy demand PJ/a**

	2012	2020	2025	2030	2040	2050
<b>Total (incl. non-energy use)</b>	<b>50,988</b>	<b>49,081</b>	<b>45,889</b>	<b>42,821</b>	<b>37,012</b>	<b>32,989</b>
<b>Total energy use</b>	<b>46,819</b>	<b>44,814</b>	<b>41,764</b>	<b>38,837</b>	<b>33,416</b>	<b>29,780</b>
<b>Transport</b>	<b>13,467</b>	<b>12,196</b>	<b>10,660</b>	<b>9,289</b>	<b>6,792</b>	<b>6,000</b>
Oil products	12,512	11,009	9,177	7,084	2,583	969
Natural gas	109	161	187	189	189	186
Biofuels	606	639	616	585	561	544
Synfuels	0	0	0	0	0	0
Electricity	240	381	594	1,062	2,070	2,415
RES electricity	67	159	322	702	1,727	2,293
Hydrogen	0	5	86	370	1,389	1,885
<b>RES share Transport</b>	<b>5%</b>	<b>7%</b>	<b>9%</b>	<b>16%</b>	<b>51%</b>	<b>77%</b>
<b>Industry</b>	<b>12,059</b>	<b>11,880</b>	<b>11,350</b>	<b>10,784</b>	<b>9,660</b>	<b>8,758</b>
Electricity	4,090	4,241	4,196	4,209	4,204	4,133
RES electricity	1,140	1,773	2,277	2,781	3,509	3,925
Public district heat	677	729	797	908	1,004	955
RES district heat	140	248	430	593	821	858
Hard coal & lignite	1,237	1,035	805	332	153	88
Oil products	1,375	1,011	574	295	105	14
Gas	3,900	3,767	3,780	3,397	2,058	1,053
Solar	12	87	292	475</		

# OECD EUROPE: ADVANCED ENERGY [R]EVOLUTION SCENARIO

Table 13.4.15 OECD Europe: Electricity generation TWh/a

	2012	2020	2025	2030	2040	2050
<b>Power plants</b>	<b>2,928</b>	<b>3,028</b>	<b>3,088</b>	<b>3,346</b>	<b>4,183</b>	<b>5,054</b>
Hard coal (& non-renewable waste)	454	323	248	199	13	0
Lignite	256	183	59	22	0	0
Gas	400	540	554	554	283	70
<i>of which from H:</i>						
Oil	0	0	3	11	40	70
Diesel	35	3	0	0	0	0
Nuclear	869	560	360	80	0	0
Biomass (& renewable waste)	55	120	122	120	120	102
Hydro	562	591	596	600	610	620
Wind	208	485	736	1,068	1,822	2,351
<i>of which wind offshore</i>	18	60	150	294	625	901
PV	67	188	325	468	760	1,080
Geothermal	4	13	33	66	144	241
Solar thermal power plants	1	13	36	128	318	430
Ocean energy	0	2	14	35	110	160
<b>Combined heat and power plants</b>	<b>674</b>	<b>721</b>	<b>763</b>	<b>805</b>	<b>790</b>	<b>710</b>
Hard coal (& non-renewable waste)	148	104	64	36	0	0
Lignite	90	67	26	3	0	0
Gas	306	350	371	376	307	170
<i>of which from H:</i>						
Oil	33	24	7	0	0	0
Biomass (& renewable waste)	96	171	278	351	366	365
Geothermal	2	5	15	39	111	149
Hydrogen	0	0	0	0	6	27
<b>CHP by producer</b>						
Main activity producers	477	510	525	540	515	460
Autoproducers	197	211	238	265	275	250
<b>Total generation</b>	<b>3,602</b>	<b>3,749</b>	<b>3,851</b>	<b>4,151</b>	<b>4,973</b>	<b>5,764</b>
Fossil	1,729	1,601	1,311	1,177	524	0
Hard coal (& non-renewable waste)	601	427	312	235	13	0
Lignite	346	250	85	25	0	0
Gas	706	890	920	911	507	0
Oil	68	27	8	0	0	0
Diesel	8	7	6	5	3	0
Nuclear	869	560	360	80	0	0
Hydrogen	0	0	3	13	80	267
<i>of which renewable H:</i>						
Hydro	562	591	596	600	610	620
Wind	208	485	736	1,068	1,822	2,351
PV	67	188	325	468	760	1,080
Biomass (& renewable waste)	151	292	400	471	486	467
Geothermal	12	18	48	104	255	390
Solar thermal power plants	4	13	36	128	318	430
Ocean energy	0	2	14	35	110	160
Distribution losses	248	255	245	240	230	230
Own consumption electricity	281	240	228	217	173	134
Electricity for hydrogen production	0	18	93	295	1,022	1,924
Electricity for synfuel production	0	0	21	37	90	207
<b>Final energy consumption (electricity)</b>	<b>3,067</b>	<b>3,250</b>	<b>3,309</b>	<b>3,515</b>	<b>3,859</b>	<b>3,889</b>
Fluctuating RES (PV, Wind, Ocean)	275	675	1,075	1,571	2,692	3,591
Share of fluctuating RES	8%	18%	28%	38%	54%	62%
<b>RES share (domestic generation)</b>	<b>28%</b>	<b>42%</b>	<b>56%</b>	<b>70%</b>	<b>89%</b>	<b>100%</b>

Table 13.4.16 OECD Europe: Final energy consumption in transport PJ/a

	2012	2020	2025	2030	2040	2050
<b>Road</b>	<b>12,527</b>	<b>10,985</b>	<b>9,099</b>	<b>7,406</b>	<b>4,404</b>	<b>3,505</b>
Fossil fuels	11,864	10,080	7,823	5,468	917	0
Biofuels	606	618	602	496	382	194
Synfuels	0	0	28	45	90	112
Natural gas	56	109	122	98	27	0
Hydrogen	0	45	147	450	1,383	1,611
Electricity	2	132	404	894	1,695	1,700
<b>Rail</b>	<b>387</b>	<b>422</b>	<b>494</b>	<b>570</b>	<b>743</b>	<b>866</b>
Fossil fuels	149	122	93	64	24	0
Biofuels	0	6	9	10	13	9
Synfuels	0	0	0	1	3	5
Electricity	238	294	392	495	703	852
<b>Navigation</b>	<b>238</b>	<b>290</b>	<b>284</b>	<b>265</b>	<b>247</b>	<b>240</b>
Fossil fuels	238	276	281	229	161	0
Biofuels	0	15	3	33	70	152
Synfuels	0	0	0	3	17	87
<b>Aviation</b>	<b>262</b>	<b>376</b>	<b>388</b>	<b>385</b>	<b>339</b>	<b>296</b>
Fossil fuels	262	376	386	335	221	0
Biofuels	0	0	2	46	96	188
Synfuels	0	0	0	4	23	108
<b>Total (incl. pipelines)</b>	<b>13,467</b>	<b>12,123</b>	<b>10,336</b>	<b>8,710</b>	<b>5,851</b>	<b>5,034</b>
Fossil fuels	12,512	10,854	8,583	6,096	1,322	0
Biofuels (incl. biogas)	606	639	616	585	561	544
Synfuels	0	0	28	53	133	312
Natural gas	109	158	165	134	43	0
Hydrogen	0	45	147	450	1,383	1,611
Electricity	240	426	797	1,392	2,409	2,567
<b>Total RES</b>	<b>672</b>	<b>839</b>	<b>1,161</b>	<b>1,903</b>	<b>4,065</b>	<b>5,034</b>
<b>RES share</b>	<b>5%</b>	<b>7%</b>	<b>11%</b>	<b>22%</b>	<b>69%</b>	<b>100%</b>

Table 13.4.17 OECD Europe: Heat supply PJ/a

	2012	2020	2025	2030	2040	2050
<b>District heating plants</b>	<b>641</b>	<b>645</b>	<b>807</b>	<b>859</b>	<b>1,244</b>	<b>1,436</b>
Fossil fuels	486	429	337	262	119	0
Biomass	149	190	242	245	261	244
Solar collectors	0	6	145	219	585	833
Geothermal	6	19	83	133	279	359
<b>Heat from CHP<sup>1</sup></b>	<b>1,696</b>	<b>1,962</b>	<b>2,370</b>	<b>2,756</b>	<b>3,358</b>	<b>3,913</b>
Fossil fuels	1,364	1,311	1,171	1,031	713	0
Biomass	322	618	1,087	1,426	1,645	2,005
Geothermal	10	33	107	278	837	1,156
Hydrogen	0	0	4	21	163	752
<b>Direct heating</b>	<b>19,089</b>	<b>18,537</b>	<b>17,477</b>	<b>16,505</b>	<b>14,684</b>	<b>12,797</b>
Fossil fuels	14,447	13,132	11,000	8,831	4,057	0
Biomass	1,916	2,128	2,119	2,041	1,864	1,691
Solar collectors	107	355	1,004	1,597	2,624	3,184
Geothermal	0	0	0	0	0	0
Heat pumps <sup>2</sup>	163	435	840	1,459	2,992	3,786
Electric direct heating	2,457	2,487	2,471	2,424	2,555	2,605
Hydrogen	0	0	43	153	593	1,531
<b>Total heat supply<sup>3</sup></b>	<b>21,425</b>	<b>21,144</b>	<b>20,654</b>	<b>20,120</b>	<b>19,287</b>	<b>18,145</b>
Fossil fuels	16,296	14,872	12,509	10,124	4,889	0
Biomass	2,387	2,937	3,448	3,712	3,770	3,940
Solar collectors	107	362	1,149	1,816	3,209	4,016
Geothermal	15	52	190	411	1,116	1,515
Heat pumps <sup>2</sup>	163	435	840	1,459	2,992	3,786
Electric direct heating	2,457	2,487	2,471	2,424	2,555	2,605
Hydrogen	0	0	48	174	756	2,283
<b>RES share (including RES electricity)</b>	<b>16%</b>	<b>23%</b>	<b>35%</b>	<b>46%</b>	<b>73%</b>	<b>100%</b>

<sup>1</sup> public CHP and CHP autoproduction / <sup>2</sup> heat from ambient energy and electricity use / <sup>3</sup> incl. process heat, cooking

Table 13.4.18: OECD Europe: Installed capacity GW

	2012	2020	2025	2030	2040	2050
<b>Total generation</b>	<b>1,020</b>	<b>1,203</b>	<b>1,349</b>	<b>1,577</b>	<b>2,066</b>	<b>2,460</b>
<b>Fossil</b>	<b>483</b>	<b>458</b>	<b>380</b>	<b>344</b>	<b>217</b>	<b>0</b>
Hard coal (& non-renewable waste)	117	88	62	47	3	0
Lignite	67	51	17	5	0	0
Gas (w/o H)	240	286	288	287	211	0
Oil	53	26	7	0	0	0
Diesel	6	6	6	5	3	0
Nuclear	127	61	52	11	0	0
Hydrogen (fuel cells, gas power plants, gas CHP)	0	0	1	6	36	181
<b>Renewables</b>	<b>409</b>	<b>664</b>	<b>915</b>	<b>1,216</b>	<b>1,813</b>	<b>2,279</b>
Hydro	202	214	216	216	219	223
Wind	102	210	300	416	672	831
<i>of which wind offshore</i>	5	17	42	82	169	237
Biomass (& renewable waste)	68	173	297	425	675	926
Geothermal	33	61	81	100	105	108
Solar thermal power plants	2	4	10	30	66	85
Ocean energy	0	1	6	14	42	53
Fluctuating RES (PV, Wind, Ocean)	170	383	603	856	1,388	1,811
Share of fluctuating RES	17%	32%	45%	54%	67%	74%
<b>RES share (domestic generation)</b>	<b>40%</b>	<b>55%</b>	<b>68%</b>	<b>77%</b>	<b>88%</b>	<b>93%</b>

Table 13.4.19: OECD Europe: Final energy demand PJ/a

	2012	2020	2025	2030	2040	2050
<b>Total (incl. non-energy use)</b>	<b>50,988</b>	<b>49,008</b>	<b>45,565</b>	<b>42,458</b>	<b>36,562</b>	<b>32,798</b>
<b>Total energy use</b>	<b>46,819</b>	<b>44,742</b>	<b>41,440</b>	<b>38,475</b>	<b>32,966</b>	<b>29,589</b>
<b>Transport</b>	<b>13,467</b>	<b>12,123</b>	<b>10,336</b>	<b>8,710</b>	<b>5,851</b>	<b>5,034</b>
Oil products	12,512	10,854	8,583	6,096	1,322	0
Natural gas	109	158	165	134	43	0
Biofuels	606	639	616	585	561	544
Synfuels	0	0	28	53	133	312
Electricity	400	426	797	1,392	2,409	2,567
<i>RES electricity</i>	27	181	447	969	2,151	2,567
Hydrogen	0	45	147	450	1,383	1,611
<b>RES share Transport</b>	<b>5%</b>	<b>7%</b>	<b>11%</b>	<b>22%</b>	<b>69%</b>	<b>100%</b>
<b>Industry</b>	<b>12,059</b>	<b>11,880</b>	<b>11,350</b>	<b>10,826</b>	<b>9,758</b>	<b>8,911</b>
Electricity	4,030	4,241	4,196	4,268	4,444	4,548
<i>RES electricity</i>	1,140	1,737	2,351	2,970	3,967	4,548
Public district heat	677	729	797	908	1,004	955
<i>RES district heat</i>	140	248	430	596	834	955
Hard coal & lignite	1,237	1,035	605	332	137	0
Oil products	1,375	1,011	574	285	88	0
Gas	3,900	3,767	3,761	3,323	1,684	0
Solar	12	87	292	475	768	990
Biomass	767	959	1,016	970	869	832
Geothermal	2	51	91	197	493	568
Hydrogen	0	0	19	67	271	1,018
<b>RES share Industry</b>	<b>17%</b>					

Table 13.4.22: OECD Europe: Investments in electricity generation

REF	UNIT	2012-2020	2021-2030	2031-2040	2041-2050	2012-2050	UNIT	ANNUAL AVERAGE 2012-2050
Fossil (w/o CHP)	billion \$	177.1	187.9	202.1	243.1	810.2	billion \$/a	20.8
Nuclear	billion \$	135.6	17.1	79.8	77.7	310.1	billion \$/a	8.0
CHP (fossil + renewable)	billion \$	190.8	133.8	73.9	27.0	425.5	billion \$/a	10.9
Renewables (w/o CHP)	billion \$	520.5	461.4	632.2	537.2	2,151.3	billion \$/a	55.2
<b>Total</b>	<b>billion \$</b>	<b>1,024.0</b>	<b>800.2</b>	<b>988.0</b>	<b>884.9</b>	<b>3,697.1</b>	<b>billion \$/a</b>	<b>94.8</b>
Conventional (fossil & nuclear)	billion \$	456.6	285.2	311.4	321.1	1,376.4	billion \$/a	35.3
Renewables	billion \$	565.4	515.0	676.6	563.8	2,320.8	billion \$/a	59.5
Biomass	billion \$	63.8	71.3	68.2	47.1	250.4	billion \$/a	6.4
Hydro	billion \$	128.8	133.9	126.5	134.0	523.2	billion \$/a	13.4
Wind	billion \$	206.7	228.8	296.1	280.5	1,014.1	billion \$/a	26.0
PV	billion \$	138.4	52.4	109.9	39.8	340.6	billion \$/a	8.7
Geothermal	billion \$	9.9	8.2	11.2	8.7	38.0	billion \$/a	1.0
Solar thermal power plants	billion \$	13.9	11.8	33.4	32.9	92.0	billion \$/a	2.4
Ocean energy	billion \$	1.9	8.6	31.1	20.8	62.4	billion \$/a	1.6
<b>E[R]</b>								
Fossil (w/o CHP)	billion \$	148.9	81.3	66.8	96.6	393.7	billion \$/a	10.1
Nuclear	billion \$	61.1	0.0	0.0	0.0	61.1	billion \$/a	1.6
CHP (fossil + renewable)	billion \$	224.4	259.6	195.3	179.0	858.2	billion \$/a	22.0
Renewables (w/o CHP)	billion \$	685.0	994.7	1,323.5	1,174.6	4,177.7	billion \$/a	107.1
<b>Total</b>	<b>billion \$</b>	<b>1,119.4</b>	<b>1,335.5</b>	<b>1,585.6</b>	<b>1,450.2</b>	<b>5,490.7</b>	<b>billion \$/a</b>	<b>140.8</b>
Conventional (fossil & nuclear)	billion \$	349.0	137.6	110.2	96.6	693.5	billion \$/a	17.8
Renewables	billion \$	770.4	1,197.9	1,475.4	1,353.6	4,797.2	billion \$/a	123.0
Biomass	billion \$	108.1	184.3	102.8	140.4	535.6	billion \$/a	13.7
Hydro	billion \$	128.8	105.5	110.9	117.8	462.9	billion \$/a	11.9
Wind	billion \$	268.2	448.2	590.0	546.8	1,853.2	billion \$/a	47.5
PV	billion \$	232.2	257.4	326.2	240.2	1,066.0	billion \$/a	27.1
Geothermal	billion \$	13.3	73.5	111.5	135.6	333.9	billion \$/a	8.6
Solar thermal power plants	billion \$	15.4	71.3	153.8	138.7	379.2	billion \$/a	9.7
Ocean energy	billion \$	4.3	57.7	80.3	34.1	176.4	billion \$/a	4.5
<b>ADV E[R]</b>								
Fossil (w/o CHP)	billion \$	126.4	85.5	56.0	112.0	380.0	billion \$/a	9.7
Nuclear	billion \$	61.1	0.0	0.0	0.0	61.1	billion \$/a	1.6
CHP (fossil + renewable)	billion \$	224.4	259.6	195.3	188.9	868.1	billion \$/a	22.3
Renewables (w/o CHP)	billion \$	711.2	1,347.5	1,767.3	1,649.9	5,476.0	billion \$/a	140.4
<b>Total</b>	<b>billion \$</b>	<b>1,123.1</b>	<b>1,692.6</b>	<b>2,018.6</b>	<b>1,950.9</b>	<b>6,785.2</b>	<b>billion \$/a</b>	<b>174.0</b>
Conventional (fossil & nuclear)	billion \$	326.5	141.9	99.4	112.0	679.8	billion \$/a	17.4
Renewables	billion \$	796.6	1,550.7	1,919.3	1,838.9	6,105.4	billion \$/a	156.5
Biomass	billion \$	117.8	186.1	118.9	146.8	569.6	billion \$/a	14.6
Hydro	billion \$	128.8	105.5	110.9	117.8	462.9	billion \$/a	11.9
Wind	billion \$	273.7	579.2	833.0	850.1	2,536.0	billion \$/a	65.0
PV	billion \$	240.1	363.8	410.6	413.3	1,427.9	billion \$/a	36.6
Geothermal	billion \$	14.7	99.4	148.0	144.1	406.1	billion \$/a	10.4
Solar thermal power plants	billion \$	17.1	148.7	199.3	128.1	493.3	billion \$/a	12.6
Ocean energy	billion \$	4.3	68.0	98.6	38.7	209.6	billion \$/a	5.4

Table 13.4.23: OECD Europe: Investments in renewable heat generation

REF	UNIT	2012-2020	2021-2030	2031-2040	2041-2050	2012-2050	UNIT	ANNUAL AVERAGE 2012-2050
Heat pumps	billion \$	46.8	46.2	55.0	60.1	208.0	billion \$/a	5.3
Deep geothermal	billion \$	6.2	0.5	10.0	6.1	22.8	billion \$/a	0.6
Solar thermal	billion \$	47.3	50.3	71.0	71.7	239.7	billion \$/a	6.1
Biomass	billion \$	169.2	200.1	81.2	71.7	522.2	billion \$/a	13.4
<b>Total</b>	<b>billion \$</b>	<b>269.5</b>	<b>297.1</b>	<b>217.2</b>	<b>208.9</b>	<b>992.7</b>	<b>billion \$/a</b>	<b>25.5</b>
<b>E[R]</b>								
Heat pumps	billion \$	104.0	319.8	454.9	460.6	1,339.2	billion \$/a	34.3
Deep geothermal	billion \$	10.8	8.2	88.7	37.6	145.3	billion \$/a	3.7
Solar thermal	billion \$	91.4	376.1	328.0	424.0	1,219.4	billion \$/a	31.3
Biomass	billion \$	89.8	22.1	3.0	0.0	114.9	billion \$/a	2.9
<b>Total</b>	<b>billion \$</b>	<b>296.0</b>	<b>726.2</b>	<b>874.6</b>	<b>922.1</b>	<b>2,818.9</b>	<b>billion \$/a</b>	<b>72.3</b>
<b>ADV E[R]</b>								
Heat pumps	billion \$	104.0	319.8	477.0	479.0	1,379.7	billion \$/a	35.4
Deep geothermal	billion \$	10.8	8.2	88.7	93.6	201.3	billion \$/a	5.2
Solar thermal	billion \$	91.4	376.1	364.4	437.0	1,269.0	billion \$/a	32.5
Biomass	billion \$	89.8	22.1	3.0	0.3	115.2	billion \$/a	3.0
<b>Total</b>	<b>billion \$</b>	<b>296.0</b>	<b>726.2</b>	<b>933.1</b>	<b>1,009.9</b>	<b>2,965.2</b>	<b>billion \$/a</b>	<b>76.0</b>

Table 13.4.24: OECD Europe: Total employment in the energy sector THOUSAND JOBS

By sector	REFERENCE SCENARIO				ADV E[R] SCENARIO		
	2015	2020	2025	2030	2020	2025	2030
Construction and installation	138	83	90	85	388	458	442
Manufacturing	119	75	72	58	437	516	533
Operations and maintenance	380	402	405	407	443	535	623
Fuel supply (domestic)	551	526	514	502	540	513	475
Coal and gas export	-	-	-	-	-	-	-
Solar and geothermal heat	89	59	71	68	243	753	691
<b>Total jobs (thousands)</b>	<b>1,278</b>	<b>1,145</b>	<b>1,152</b>	<b>1,120</b>	<b>2,051</b>	<b>2,774</b>	<b>2,764</b>
<b>By technology</b>							
Coal	294	253	228	209	246	177	135
Gas, oil & diesel	175	178	180	176	162	166	157
Nuclear	84	82	81	80	96	101	110
<b>Renewable</b>	<b>725</b>	<b>631</b>	<b>662</b>	<b>654</b>	<b>1,547</b>	<b>2,330</b>	<b>2,363</b>
Biomass	276	296	313	328	391	459	455
Hydro	60	57	59	58	48	48	51
Wind	129	116	122	110	341	434	486
PV	164	93	86	70	468	517	512
Geothermal power	1.8	1.6	1.5	1.4	10	15	20
Solar thermal power	5.5	6.5	7.2	10.0	29	71	102
Ocean	0.6	2.3	2.7	8.7	16.6	32	46
Solar - heat	74	48	60	59	186	636	544
Geothermal & heat pump	14.7	10.7	10.2	9.6	57	117	146
<b>Total jobs (thousands)</b>	<b>1,278</b>	<b>1,145</b>	<b>1,152</b>	<b>1,120</b>	<b>2,051</b>	<b>2,774</b>	<b>2,764</b>

# AFRICA: REFERENCE SCENARIO

Table 13.5.1 Africa: Electricity generation TWh/a

	2012	2020	2025	2030	2040	2050
<b>Power plants</b>	<b>716</b>	<b>1,014</b>	<b>1,237</b>	<b>1,457</b>	<b>2,068</b>	<b>2,680</b>
Hard coal (& non-renewable waste)	256	314	352	389	501	649
Lignite	0	0	0	0	0	0
Gas	256	384	482	579	823	917
<i>of which from H:</i>						
Oil	68	86	79	71	64	60
Diesel	7	7	9	11	15	16
Nuclear	13	13	19	25	41	65
Biomass (& renewable waste)	2	9	16	23	39	61
Hydro	112	167	212	258	368	509
Wind	2	13	22	30	51	81
<i>of which wind offshore</i>	0	0	0	1	3	8
PV	0	10	22	34	65	113
Geothermal	2	8	16	23	58	118
Solar thermal power plants	0	3	8	14	41	91
<b>Ocean energy</b>	<b>0</b>	<b>0</b>	<b>0</b>	<b>0</b>	<b>0</b>	<b>0</b>
<b>Combined heat and power plants</b>	<b>0</b>	<b>3</b>	<b>8</b>	<b>16</b>	<b>29</b>	<b>42</b>
Hard coal (& non-renewable waste)	0	1	4	7	12	15
Lignite	0	0	0	0	0	0
Gas	0	1	3	5	10	16
<i>of which from H:</i>						
Oil	0	0	0	0	0	0
Biomass (& renewable waste)	0	1	2	3	7	10
Geothermal	0	0	0	0	0	0
Hydrogen	0	0	0	0	0	0
<b>CHP by producer</b>						
Main activity producers	0	0	0	0	0	0
Autoproducers	0	3	8	16	29	42
<b>Total generation</b>	<b>716</b>	<b>1,017</b>	<b>1,245</b>	<b>1,473</b>	<b>2,097</b>	<b>2,722</b>
Fossil	585	794	928	1,063	1,426	1,674
Hard coal (& non-renewable waste)	256	316	356	396	513	664
Lignite	0	0	0	0	0	0
Gas	256	385	484	584	833	933
Oil	68	86	79	71	64	61
Diesel	5	7	9	11	15	16
Nuclear	13	13	19	25	41	65
Hydrogen	0	0	0	0	0	0
<i>of which renewable H:</i>						
Hydro	112	167	212	258	368	509
Wind	2	13	22	30	51	81
PV	0	10	22	34	65	113
Biomass (& renewable waste)	2	9	18	27	45	72
Geothermal	2	8	16	23	58	118
Solar thermal power plants	0	3	8	14	41	91
Ocean energy	0	0	0	0	0	0
Distribution losses	88	126	155	184	263	345
Own consumption electricity	47	63	69	74	87	91
Electricity for hydrogen production	0	0	0	0	0	0
Electricity for synfuel production	0	0	0	0	0	0
<b>Final energy consumption (electricity)</b>	<b>588</b>	<b>837</b>	<b>1,030</b>	<b>1,223</b>	<b>1,752</b>	<b>2,293</b>
Fluctuating RES (PV, Wind, Ocean)	3	24	44	64	117	194
Share of fluctuating RES	0%	2%	4%	4%	6%	7%
<b>RES share (domestic generation)</b>	<b>17%</b>	<b>21%</b>	<b>24%</b>	<b>26%</b>	<b>30%</b>	<b>36%</b>

Table 13.5.2 Africa: Final energy consumption in transport PJ/a

	2012	2020	2025	2030	2040	2050
<b>Road</b>	<b>3,657</b>	<b>4,405</b>	<b>5,110</b>	<b>5,786</b>	<b>7,839</b>	<b>9,881</b>
Fossil fuels	3,640	4,387	5,086	5,758	7,795	9,820
Biofuels	0	0	0	0	0	0
Synfuels	0	0	0	0	0	0
Natural gas	17	16	18	20	26	35
Hydrogen	0	0	0	0	0	0
Electricity	0	3	6	9	17	26
<b>Rail</b>	<b>32</b>	<b>34</b>	<b>35</b>	<b>37</b>	<b>39</b>	<b>42</b>
Fossil fuels	12	13	14	14	15	17
Biofuels	0	0	0	0	0	0
Synfuels	0	0	0	0	0	0
Electricity	20	21	22	22	24	25
<b>Navigation</b>	<b>26</b>	<b>30</b>	<b>30</b>	<b>31</b>	<b>31</b>	<b>32</b>
Fossil fuels	26	30	30	31	31	32
Biofuels	0	0	0	0	0	0
Synfuels	0	0	0	0	0	0
<b>Aviation</b>	<b>105</b>	<b>139</b>	<b>140</b>	<b>170</b>	<b>275</b>	<b>389</b>
Fossil fuels	105	139	140	170	275	389
Biofuels	0	0	0	0	0	0
Synfuels	0	0	0	0	0	0
<b>Total (incl. pipelines)</b>	<b>3,857</b>	<b>4,650</b>	<b>5,361</b>	<b>6,071</b>	<b>8,238</b>	<b>10,405</b>
Fossil fuels	3,783	4,568	5,270	5,972	8,117	10,258
Biofuels (incl. biogas)	0	0	0	0	0	0
Synfuels	0	0	0	0	0	0
Natural gas	54	58	63	68	81	95
Hydrogen	0	0	0	0	0	0
Electricity	20	24	28	32	41	51
<b>Total RES</b>	<b>3</b>	<b>5</b>	<b>7</b>	<b>8</b>	<b>12</b>	<b>19</b>
<b>RES share</b>	<b>0%</b>	<b>0%</b>	<b>0%</b>	<b>0%</b>	<b>0%</b>	<b>0%</b>

Table 13.5.3 Africa: Heat supply PJ/a

	2012	2020	2025	2030	2040	2050
<b>District heating plants</b>	<b>0</b>	<b>0</b>	<b>0</b>	<b>0</b>	<b>0</b>	<b>0</b>
Fossil fuels	0	0	0	0	0	0
Biomass	0	0	0	0	0	0
Solar collectors	0	0	0	0	0	0
Geothermal	0	0	0	0	0	0
<b>Heat from CHP<sup>1</sup></b>	<b>0</b>	<b>8</b>	<b>22</b>	<b>49</b>	<b>114</b>	<b>243</b>
Fossil fuels	0	6	18	39	87	169
Biomass	0	1	4	10	27	74
Geothermal	0	0	0	0	0	0
Hydrogen	0	0	0	0	0	0
<b>Direct heating</b>	<b>7,354</b>	<b>9,295</b>	<b>10,439</b>	<b>11,635</b>	<b>14,366</b>	<b>16,825</b>
Fossil fuels	2,710	3,614	4,193	4,782	6,380	7,892
Biomass	4,334	5,273	5,792	6,344	7,322	8,106
Solar collectors	5	17	33	50	104	186
Geothermal	0	0	0	0	0	0
Heat pumps <sup>2</sup>	0	0	0	0	0	0
Electric direct heating	305	390	420	460	560	641
Hydrogen	0	0	0	0	0	0
<b>Total heat supply<sup>3</sup></b>	<b>7,354</b>	<b>9,302</b>	<b>10,461</b>	<b>11,685</b>	<b>14,480</b>	<b>17,068</b>
Fossil fuels	2,710	3,621	4,211	4,822	6,467	8,061
Biomass	4,334	5,274	5,796	6,354	7,349	8,180
Solar collectors	5	17	33	50	104	186
Geothermal	0	0	0	0	0	0
Heat pumps <sup>2</sup>	0	0	0	0	0	0
Electric direct heating	305	390	420	460	560	641
Hydrogen	0	0	0	0	0	0
<b>RES share (including RES electricity)</b>	<b>60%</b>	<b>58%</b>	<b>57%</b>	<b>56%</b>	<b>53%</b>	<b>50%</b>

<sup>1</sup> public CHP and CHP autoproduction / <sup>2</sup> heat from ambient energy and electricity use / <sup>3</sup> incl. process heat, cooking

Table 13.5.4: Africa: Installed capacity GW

	2012	2020	2025	2030	2040	2050
<b>Total generation</b>	<b>157</b>	<b>249</b>	<b>308</b>	<b>367</b>	<b>522</b>	<b>674</b>
<b>Fossil</b>	<b>129</b>	<b>193</b>	<b>226</b>	<b>258</b>	<b>341</b>	<b>395</b>
Hard coal (& non-renewable waste)	42	58	68	77	101	131
Lignite	0	0	0	0	0	0
Gas (w/o H)	59	100	123	145	205	229
Oil	26	33	32	30	27	27
Diesel	2	3	4	5	7	7
Nuclear	2	2	3	4	6	9
Hydrogen (fuel cells, gas power plants, gas CHP)	0	0	0	0	0	0
<b>Renewables</b>	<b>26</b>	<b>54</b>	<b>80</b>	<b>105</b>	<b>175</b>	<b>271</b>
Hydro	25	38	49	60	86	119
Wind	0	5	8	12	19	30
<i>of which wind offshore</i>	0	0	0	0	0	0
Biomass (& renewable waste)	0	2	4	6	9	14
Geothermal	0	1	2	4	9	18
Solar thermal power plants	0	1	3	4	11	20
Ocean energy	0	0	0	0	0	0
Fluctuating RES (PV, Wind, Ocean)	1	12	22	32	59	99
Share of fluctuating RES	1%	5%	7%	9%	11%	15%
<b>RES share (domestic generation)</b>	<b>17%</b>	<b>22%</b>	<b>26%</b>	<b>29%</b>	<b>33%</b>	<b>40%</b>

Table 13.5.5: Africa: Final energy demand PJ/a

	2012	2020	2025	2030	2040	2050
<b>Total (incl. non-energy use)</b>	<b>22,565</b>	<b>27,547</b>	<b>30,556</b>	<b>33,564</b>	<b>40,579</b>	<b>47,275</b>
<b>Total energy use</b>	<b>21,718</b>	<b>26,559</b>	<b>29,483</b>	<b>32,409</b>	<b>39,263</b>	<b>45,727</b>
<b>Transport</b>	<b>3,857</b>	<b>4,650</b>	<b>5,361</b>	<b>6,071</b>	<b>8,238</b>	<b>10,405</b>
Oil products	3,783	4,568	5,270	5,972	8,117	10,258
Natural gas	54	58	63	68	81	95
Biofuels	0	0	0	0	0	0
Synfuels	0	0	0	0	0	0
Electricity	20	24	28	32	41	51
RES electricity	3	5	7	8	12	19
Hydrogen	0	0	0	0	0	0
<b>RES share Transport</b>	<b>0%</b>	<b>0%</b>	<b>0%</b>	<b>0%</b>	<b>0%</b>	<b>0%</b>
<b>Industry</b>	<b>3,447</b>	<b>4,561</b>	<b>5,314</b>	<b>6,068</b>	<b>8,262</b>	<b>10,116</b>
Electricity	872	1,180	1,398	1,616	2,247	3,015
RES electricity	144	244	335	423	674	1,089
Public district heat	0	0	0	0	0	0
RES district heat	0	0	0	0	0	0
Hard coal & lignite	350	623	713	804	1,072	1,236
Oil products	650	779	848	917	1,064	1,095
Gas	738	872	996	1,120	1,441	1,632
Solar	0	4	8	12	29	54
Biomass	837	1,104	1,351	1,599	2,409	3,085
Geothermal	0	0	0	0	0	0
Hydrogen	0	0	0	0	0	0
<b>RES share Industry</b>	<b>28%</b>	<b>30%</b>	<b>32%</b>	<b>34%</b>	<b>38%</b>	<b>42%</b>
<b>Other Sectors</b>	<b>14,413</b>	<b>17,349</b>	<b>18,808</b>	<b>20,269</b>	<b>22,763</b>	<b>25,207</b>
Electricity	1,223	1,809	2,283	2,756	4,020	5,188
RES electricity	202	374	546	722	1,206	1,875
Public district heat	0	0	0	0	0	0
RES district heat	0	0	0	0	0	0
Hard coal & lignite	295	296	302	309	335	363
Oil products	1,107	1,566	1,858	2,151	2,950	3,966
Gas	305	354	417	480	655	874
Solar	5	14	26	38	75	132
Biomass	11,479	13,310	13,923	14,536</		

**Table 13.5.8 Africa: Electricity generation TWh/a**

	2012	2020	2025	2030	2040	2050
<b>Power plants</b>	<b>716</b>	<b>971</b>	<b>1,132</b>	<b>1,450</b>	<b>2,503</b>	<b>4,096</b>
Hard coal (& non-renewable waste)	256	251	216	159	11	0
Lignite	0	0	0	0	0	0
Gas	256	356	354	301	206	130
<i>of which from H:</i>						
Oil	68	54	39	20	6	0
Diesel	5	6	6	5	4	3
Nuclear	13	8	4	0	0	0
Biomass (& renewable waste)	2	13	14	16	16	18
Hydro	112	150	162	175	200	225
Wind	2	58	139	284	631	961
<i>of which wind offshore</i>	0	1	18	85	222	350
PV	0	44	126	290	690	1,089
Geothermal	2	8	25	61	125	208
Solar thermal power plants	0	23	42	122	564	1,362
Ocean energy	0	0	5	18	50	100
<b>Combined heat and power plants</b>	<b>0</b>	<b>10</b>	<b>68</b>	<b>98</b>	<b>145</b>	<b>170</b>
Hard coal (& non-renewable waste)	0	0	0	0	0	0
Lignite	0	0	0	0	0	0
Gas	0	4	31	49	74	78
<i>of which from H:</i>						
Oil	0	0	0	0	0	0
Biomass (& renewable waste)	0	6	35	44	52	56
Geothermal	0	0	1	4	12	17
Hydrogen	0	0	0	0	7	19
<b>CHP by producer</b>						
Main activity producers	0	0	0	0	0	0
Autoproducers	0	10	68	98	145	170
<b>Total generation</b>	<b>716</b>	<b>981</b>	<b>1,199</b>	<b>1,548</b>	<b>2,648</b>	<b>4,266</b>
Fossil	585	671	646	534	297	183
Hard coal (& non-renewable waste)	256	251	216	159	11	0
Lignite	0	0	0	0	0	0
Gas	256	360	385	350	276	180
Oil	68	54	39	20	6	0
Diesel	5	6	6	5	4	3
Nuclear	13	8	4	0	0	0
Hydrogen	0	0	0	0	11	46
<i>of which renewable H:</i>						
Hydro	112	150	162	175	200	225
Wind	2	58	139	284	631	961
PV	0	44	126	290	690	1,089
Biomass (& renewable waste)	2	19	49	60	68	74
Geothermal	2	8	26	65	137	225
Solar thermal power plants	0	23	42	122	564	1,362
Ocean energy	0	0	5	18	50	100
Distribution losses	88	126	145	177	279	434
Own consumption electricity	47	63	67	67	61	45
Electricity for hydrogen production	0	0	1	18	209	577
Electricity for synfuel production	0	0	0	0	0	0
<b>Final energy consumption (electricity)</b>	<b>588</b>	<b>791</b>	<b>966</b>	<b>1,179</b>	<b>1,859</b>	<b>2,889</b>
Fluctuating RES (PV, Wind, Ocean)	3	102	270	592	1,371	2,150
Share of fluctuating RES	0%	10%	23%	38%	52%	50%
<b>RES share (domestic generation)</b>	<b>17%</b>	<b>31%</b>	<b>46%</b>	<b>65%</b>	<b>89%</b>	<b>96%</b>

**Table 13.5.9 Africa: Final energy consumption in transport PJ/a**

	2012	2020	2025	2030	2040	2050
<b>Road</b>	<b>3,657</b>	<b>4,131</b>	<b>4,407</b>	<b>4,663</b>	<b>4,991</b>	<b>5,436</b>
Fossil fuels	3,640	4,109	4,183	4,221	3,560	2,457
Biofuels	0	0	129	222	352	434
Synfuels	0	0	0	0	0	0
Natural gas	17	21	40	46	72	163
Hydrogen	0	0	1	47	437	990
Electricity	0	2	53	127	570	1,392
<b>Rail</b>	<b>32</b>	<b>45</b>	<b>49</b>	<b>56</b>	<b>64</b>	<b>94</b>
Fossil fuels	12	19	19	18	14	8
Biofuels	0	0	1	2	4	4
Synfuels	0	0	0	0	0	0
Electricity	20	26	29	36	46	82
<b>Navigation</b>	<b>26</b>	<b>45</b>	<b>58</b>	<b>62</b>	<b>81</b>	<b>89</b>
Fossil fuels	26	44	55	55	67	62
Biofuels	0	1	3	7	15	27
Synfuels	0	0	0	0	0	0
<b>Aviation</b>	<b>105</b>	<b>125</b>	<b>139</b>	<b>150</b>	<b>194</b>	<b>244</b>
Fossil fuels	105	125	139	148	178	171
Biofuels	0	0	0	1	16	73
Synfuels	0	0	0	0	0	0
<b>Total (incl. pipelines)</b>	<b>3,857</b>	<b>4,386</b>	<b>4,694</b>	<b>4,974</b>	<b>5,374</b>	<b>5,907</b>
Fossil fuels	3,783	4,296	4,396	4,442	3,819	2,698
Biofuels (incl. biogas)	0	2	133	234	386	537
Synfuels	0	0	0	0	0	0
Natural gas	54	61	80	87	108	183
Hydrogen	0	0	1	47	437	990
Electricity	20	28	83	164	625	1,498
<b>Total RES</b>	<b>3</b>	<b>10</b>	<b>172</b>	<b>372</b>	<b>1,328</b>	<b>2,917</b>
<b>RES share</b>	<b>0%</b>	<b>0%</b>	<b>4%</b>	<b>7%</b>	<b>25%</b>	<b>49%</b>

**Table 13.5.10 Africa: Heat supply PJ/a**

	2012	2020	2025	2030	2040	2050
<b>District heating plants</b>	<b>0</b>	<b>0</b>	<b>0</b>	<b>0</b>	<b>0</b>	<b>0</b>
Fossil fuels	0	0	0	0	0	0
Biomass	0	0	0	0	0	0
Solar collectors	0	0	0	0	0	0
Geothermal	0	0	0	0	0	0
<b>Heat from CHP<sup>1</sup></b>	<b>0</b>	<b>25</b>	<b>194</b>	<b>319</b>	<b>610</b>	<b>951</b>
Fossil fuels	0	12	95	156	235	183
Biomass	0	13	87	127	215	404
Geothermal	0	0	12	35	104	153
Hydrogen	0	0	0	0	56	211
<b>Direct heating</b>	<b>7,354</b>	<b>8,593</b>	<b>9,151</b>	<b>9,703</b>	<b>11,149</b>	<b>12,566</b>
Fossil fuels	2,710	3,330	3,187	2,809	1,996	955
Biomass	4,334	4,759	5,098	5,219	5,450	4,809
Solar collectors	5	43	203	701	1,820	3,336
Geothermal	0	25	56	90	141	201
Heat pumps <sup>2</sup>	0	5	26	88	313	589
Electric direct heating	305	431	581	796	1,430	2,507
Hydrogen	0	0	0	0	0	168
<b>Total heat supply<sup>3</sup></b>	<b>7,354</b>	<b>8,619</b>	<b>9,346</b>	<b>10,022</b>	<b>11,759</b>	<b>13,517</b>
Fossil fuels	2,710	3,342	3,282	2,965	2,231	1,138
Biomass	4,334	4,772	5,185	5,346	5,664	5,213
Solar collectors	5	43	203	701	1,820	3,336
Geothermal	0	25	69	125	245	354
Heat pumps <sup>2</sup>	0	5	26	88	313	589
Electric direct heating	305	431	581	796	1,430	2,507
Hydrogen	0	0	0	0	56	379
<b>RES share (including RES electricity)</b>	<b>60%</b>	<b>58%</b>	<b>62%</b>	<b>68%</b>	<b>80%</b>	<b>91%</b>

<sup>1</sup> public CHP and CHP autoproduction / <sup>2</sup> heat from ambient energy and electricity use / <sup>3</sup> incl. process heat, cooking

**Table 13.5.10 Africa: Installed capacity GW**

	2012	2020	2025	2030	2040	2050
<b>Total generation</b>	<b>157</b>	<b>254</b>	<b>353</b>	<b>543</b>	<b>997</b>	<b>1,539</b>
<b>Fossil</b>	<b>129</b>	<b>157</b>	<b>158</b>	<b>162</b>	<b>131</b>	<b>133</b>
Hard coal (& non-renewable waste)	42	46	43	40	5	0
Lignite	0	0	0	0	0	0
Gas (w/o H <sub>2</sub> )	59	88	96	109	120	130
Oil	2	21	16	10	4	0
Diesel	2	2	2	2	2	3
Nuclear	2	1	1	0	0	0
Hydrogen (fuel cells, gas power plants, gas CHP)	0	0	0	0	3	12
<b>Renewables</b>	<b>26</b>	<b>96</b>	<b>195</b>	<b>381</b>	<b>863</b>	<b>1,394</b>
Hydro	25	34	37	41	47	53
Wind	0	23	52	102	220	333
<i>of which wind offshore</i>	0	0	5	25	65	102
PV	0	28	77	177	423	669
Biomass (& renewable waste)	0	4	10	13	15	17
Geothermal	0	1	4	10	20	34
Solar thermal power plants	0	7	11	30	113	239
Ocean energy	0	0	3	9	25	50
Fluctuating RES (PV, Wind, Ocean)	1	50	132	288	668	1,052
Share of fluctuating RES	1%	20%	37%	53%	67%	68%
<b>RES share (domestic generation)</b>	<b>17%</b>	<b>38%</b>	<b>55%</b>	<b>70%</b>	<b>87%</b>	<b>91%</b>

**Table 13.5.12 Africa: Final energy demand PJ/a**

	2012	2020	2025	2030	2040	2050
<b>Total (incl. non-energy use)</b>	<b>22,565</b>	<b>24,826</b>	<b>25,201</b>	<b>25,312</b>	<b>26,637</b>	<b>28,535</b>
<b>Total energy use</b>	<b>21,718</b>	<b>23,868</b>	<b>24,182</b>	<b>24,237</b>	<b>25,479</b>	<b>27,297</b>
<b>Transport</b>	<b>3,857</b>	<b>4,386</b>	<b>4,694</b>	<b>4,974</b>	<b>5,374</b>	<b>5,907</b>
Oil products	3,783	4,296	4,396	4,442	3,819	2,698
Natural gas	54	61	80	87	108	183
Biofuels	0	0	133	234	386	537
Synfuels	0	0	0	0	0	0
Electricity	20	28	83	164	625	1,498
RES electricity	3	9	38	108	554	1,432
Hydrogen	0	0	1	47	437	990
<b>RES share Transport</b>	<b>0%</b>	<b>0%</b>	<b>4%</b>	<b>7%</b>	<b>25%</b>	<b>49%</b>
<b>Industry</b>	<b>3,447</b>	<b>4,049</b>	<b>4,071</b>	<b>4,163</b>	<b>4,739</b>	<b>5,591</b>
Electricity	872	1,100	1,216	1,383	1,899	2,569
RES electricity	144	339	557	906	1,685	2,457
Public district heat	0	0	0	0	0	0
RES district heat	0	0	0	0	0	0
Hard coal & lignite	350	469	370	229	161	15
Oil products	650	697	594	475	114	25
Gas	738	831	839	809	766	437
Solar	0	12	49	175	461	703
Biomass	837	911	938	975	1,083	1,296
Geothermal	0	28	65	117	254	369
Hydrogen	0	0	0	0	0	177
<b>RES share Industry</b>	<b>28%</b>	<b>32%</b>	<b>40%</b>	<b>52%</b>	<b>74%</b>	<b>89%</b>
<b>Other Sectors</b>	<b>14,413</b>	<b>15,432</b>	<b>15,416</b>	<b>15,100</b>	<b>15,366</b>	<b>15,799</b>
Electricity	1,223	1,721	2,177	2,695	4,168	6,334
RES electricity	202	530	996	1,765	3,698	6,058
Public district heat	0	0	0	0	0	0
RES district heat	0	0	0	0	0	0
Hard coal & lignite						

# AFRICA: ADVANCED ENERGY [R]EVOLUTION SCENARIO

Table 13.5.15 Africa: Electricity generation TWh/a

	2012	2020	2025	2030	2040	2050
<b>Power plants</b>	<b>716</b>	<b>978</b>	<b>1,160</b>	<b>1,633</b>	<b>3,552</b>	<b>6,016</b>
Hard coal (& non-renewable waste)	256	237	154	82	1	0
Lignite	0	0	0	0	0	0
Gas	256	356	354	301	185	126
<i>of which from H/</i>						
Oil	68	54	39	20	6	0
Diesel	5	6	6	5	4	0
Nuclear	13	8	4	0	0	0
Biomass (& renewable waste)	2	18	24	26	27	30
Hydro	112	150	162	175	200	225
Wind	2	68	179	344	945	1,535
<i>of which wind offshore</i>						
Geothermal	0	8	28	95	292	450
PV	0	50	156	410	977	1,379
Solar thermal power plants	2	8	25	61	124	201
Ocean energy	0	23	52	192	994	2,340
CHP by producer						
Main activity producers	0	0	0	0	0	0
Autoproducers	0	10	68	98	145	170
<b>Total generation</b>	<b>716</b>	<b>988</b>	<b>1,227</b>	<b>1,731</b>	<b>3,697</b>	<b>6,186</b>
Fossil	585	657	584	457	198	0
Hard coal (& non-renewable waste)	256	237	154	82	1	0
Lignite	0	0	0	0	0	0
Gas	256	360	385	350	188	0
Oil	68	54	39	20	6	0
Diesel	5	6	6	5	4	0
Nuclear	13	8	4	0	0	0
Hydrogen	0	0	0	0	70	199
<i>of which renewable H/</i>						
Hydro	112	150	162	175	200	225
Wind	2	68	179	344	945	1,535
PV	0	50	156	410	977	1,379
Biomass (& renewable waste)	2	24	59	70	86	103
Geothermal	2	8	26	65	137	225
Solar thermal power plants	0	23	52	192	994	2,340
Ocean energy	0	0	5	18	90	180
Distribution losses	88	126	145	177	279	434
Own consumption electricity	47	63	67	67	61	45
Electricity for hydrogen production	0	0	1	71	687	1,338
Electricity for synfuel production	0	0	0	0	288	735
<b>Final energy consumption (electricity)</b>	<b>588</b>	<b>798</b>	<b>994</b>	<b>1,292</b>	<b>2,061</b>	<b>3,137</b>
Fluctuating RES (PV, Wind, Ocean)	3	118	340	772	2,012	3,094
Share of fluctuating RES	0%	12%	28%	45%	54%	50%
<b>RES share (domestic generation)</b>	<b>17%</b>	<b>33%</b>	<b>52%</b>	<b>74%</b>	<b>95%</b>	<b>100%</b>

Table 13.5.16 Africa: Final energy consumption in transport PJ/a

	2012	2020	2025	2030	2040	2050
<b>Road</b>	<b>3,657</b>	<b>4,072</b>	<b>4,208</b>	<b>4,324</b>	<b>3,953</b>	<b>3,521</b>
Fossil fuels	3,640	4,039	3,938	3,689	1,916	0
Biofuels	0	0	122	194	338	524
Synfuels	0	0	0	0	370	979
Natural gas	17	19	33	29	16	0
Hydrogen	0	0	1	182	926	1,542
Electricity	0	14	114	229	757	1,455
<b>Rail</b>	<b>32</b>	<b>56</b>	<b>85</b>	<b>113</b>	<b>162</b>	<b>283</b>
Fossil fuels	12	17	16	13	6	0
Biofuels	0	0	1	2	2	2
Synfuels	0	0	0	0	2	4
Electricity	20	38	68	98	151	277
<b>Navigation</b>	<b>26</b>	<b>45</b>	<b>58</b>	<b>62</b>	<b>81</b>	<b>89</b>
Fossil fuels	26	45	58	57	53	0
Biofuels	0	0	1	6	14	31
Synfuels	0	0	0	0	15	58
<b>Aviation</b>	<b>105</b>	<b>125</b>	<b>139</b>	<b>148</b>	<b>190</b>	<b>229</b>
Fossil fuels	105	124	137	135	123	0
Biofuels	0	1	1	13	32	80
Synfuels	0	0	0	0	35	149
<b>Total (incl. pipelines)</b>	<b>3,857</b>	<b>4,339</b>	<b>4,532</b>	<b>4,690</b>	<b>4,801</b>	<b>5,148</b>
Fossil fuels	3,783	4,225	4,148	3,893	2,099	0
Biofuels (incl. biogas)	0	1	125	216	386	637
Synfuels	0	0	0	0	422	1,191
Natural gas	54	60	73	68	41	0
Hydrogen	0	0	1	182	926	1,542
Electricity	20	52	184	331	929	1,778
<b>Total RES</b>	<b>3</b>	<b>19</b>	<b>222</b>	<b>594</b>	<b>2,537</b>	<b>5,148</b>
<b>RES share</b>	<b>0%</b>	<b>0%</b>	<b>5%</b>	<b>13%</b>	<b>53%</b>	<b>100%</b>

Table 13.5.17 Africa: Heat supply PJ/a

	2012	2020	2025	2030	2040	2050
<b>District heating plants</b>	<b>0</b>	<b>0</b>	<b>0</b>	<b>0</b>	<b>0</b>	<b>0</b>
Fossil fuels	0	0	0	0	0	0
Biomass	0	0	0	0	0	0
Solar collectors	0	0	0	0	0	0
Geothermal	0	0	0	0	0	0
<b>Heat from CHP<sup>1</sup></b>	<b>0</b>	<b>25</b>	<b>194</b>	<b>319</b>	<b>624</b>	<b>1,049</b>
Fossil fuels	0	12	95	156	164	0
Biomass	0	13	87	127	245	526
Geothermal	0	0	12	35	117	214
Hydrogen	0	0	0	0	98	308
<b>Direct heating</b>	<b>7,354</b>	<b>8,593</b>	<b>9,151</b>	<b>9,703</b>	<b>11,135</b>	<b>12,468</b>
Fossil fuels	2,710	3,330	3,187	2,665	1,536	0
Biomass	4,334	4,759	5,098	5,219	5,446	5,014
Solar collectors	5	43	203	701	1,818	3,315
Geothermal	0	25	56	90	140	195
Heat pumps <sup>2</sup>	0	5	26	88	312	582
Electric direct heating	305	431	581	940	1,595	2,756
Hydrogen	0	0	0	0	289	606
<b>Total heat supply<sup>3</sup></b>	<b>7,354</b>	<b>8,619</b>	<b>9,346</b>	<b>10,022</b>	<b>11,759</b>	<b>13,517</b>
Fossil fuels	2,710	3,342	3,282	2,821	1,700	0
Biomass	4,334	4,772	5,185	5,346	5,690	5,540
Solar collectors	5	43	203	701	1,818	3,315
Geothermal	0	25	69	125	257	409
Heat pumps <sup>2</sup>	0	5	26	88	312	582
Electric direct heating	305	431	581	940	1,595	2,756
Hydrogen	0	0	0	0	387	914
<b>RES share (including RES electricity)</b>	<b>60%</b>	<b>58%</b>	<b>62%</b>	<b>69%</b>	<b>85%</b>	<b>100%</b>

<sup>1</sup> public CHP and CHP autoproduction / <sup>2</sup> heat from ambient energy and electricity use / <sup>3</sup> incl. process heat, cooking

Table 13.5.18 Africa: Installed capacity GW

	2012	2020	2025	2030	2040	2050
<b>Total generation</b>	<b>157</b>	<b>260</b>	<b>378</b>	<b>639</b>	<b>1,420</b>	<b>2,180</b>
<b>Fossil</b>	<b>129</b>	<b>154</b>	<b>145</b>	<b>142</b>	<b>117</b>	<b>0</b>
Hard coal (& non-renewable waste)	42	43	31	20	0	0
Lignite	0	0	0	0	0	0
Gas (w/o H/)	59	88	96	109	111	0
Oil	26	21	16	10	4	0
Diesel	2	2	2	2	2	0
Nuclear	2	1	1	0	0	0
Hydrogen (fuel cells, gas power plants, gas CHP)	0	0	0	0	39	175
<b>Renewables</b>	<b>26</b>	<b>104</b>	<b>232</b>	<b>497</b>	<b>1,264</b>	<b>2,004</b>
Hydro	25	34	37	41	47	53
Wind	1	26	67	124	333	541
<i>of which wind offshore</i>						
PV	0	2	8	28	85	131
Biomass (& renewable waste)	0	31	96	250	598	847
Geothermal	0	5	12	15	21	30
Solar thermal power plants	0	7	14	48	199	411
Ocean energy	0	0	3	9	45	90
Fluctuating RES (PV, Wind, Ocean)	1	58	165	383	977	1,478
Share of fluctuating RES	1%	22%	44%	60%	69%	68%
<b>RES share (domestic generation)</b>	<b>17%</b>	<b>40%</b>	<b>61%</b>	<b>78%</b>	<b>89%</b>	<b>92%</b>

Table 13.5.19 Africa: Final energy demand PJ/a

	2012	2020	2025	2030	2040	2050
<b>Total (incl. non-energy use)</b>	<b>22,565</b>	<b>24,778</b>	<b>25,039</b>	<b>25,080</b>	<b>26,223</b>	<b>28,022</b>
<b>Total energy use</b>	<b>21,718</b>	<b>23,820</b>	<b>24,020</b>	<b>24,005</b>	<b>25,065</b>	<b>26,784</b>
<b>Transport</b>	<b>3,857</b>	<b>4,339</b>	<b>4,532</b>	<b>4,690</b>	<b>4,801</b>	<b>5,148</b>
Oil products	3,783	4,225	4,148	3,893	2,099	0
Natural gas	54	60	73	68	41	0
Biofuels	0	0	125	216	386	637
Synfuels	0	0	0	0	422	1,191
Electricity	20	52	184	331	929	1,778
RES electricity	3	17	96	244	878	1,778
Hydrogen	0	0	1	182	926	1,542
<b>RES share Transport</b>	<b>0%</b>	<b>0%</b>	<b>5%</b>	<b>13%</b>	<b>53%</b>	<b>100%</b>
<b>Industry</b>	<b>3,447</b>	<b>4,049</b>	<b>4,071</b>	<b>4,183</b>	<b>4,775</b>	<b>5,555</b>
Electricity	872	1,100	1,216	1,411	1,970	2,740
RES electricity	144	360	633	1,038	1,861	2,740
Public district heat	0	0	0	0	0	0
RES district heat	0	0	0	0	0	0
Hard coal & lignite	350	469	370	229	160	0
Oil products	650	697	594	471	106	0
Gas	738	831	839	806	565	0
Solar	0	12	49	175	459	682
Biomass	837	911	938	975	1,078	1,256
Geothermal	0	28	65	117	253	358
Hydrogen	0	0	0	0	186	519
<b>RES share Industry</b>	<b>28%</b>	<b>32%</b>	<b>41%</b>	<b>55%</b>	<b>80%</b>	<b>100%</b>
<b>Other Sectors</b>	<b>14,413</b>	<b>15,432</b>	<b>15,416</b>	<b>15,313</b>	<b>15,489</b>	<b>16,081</b>
Electricity	1,223	1,721	2,177	2,909	4,523	6,776
RES electricity	202	563	1,133	2,141	4,274	6,776
Public district heat	0	0	0	0	0	0
RES district heat	0	0	0	0	0	0
Hard coal & lignite	295	332	380	197	149	0
Oil products	1,107	1,362	1,218	977	396	0
Gas	305	427	498	525	394	0
Solar	5	31	154	526	1,359	2,633
Biomass	11,479	11,559	10,980	9,961	8,427	6,279
Geothermal	0	0	9	36	116	274
Hydrogen	0	0	0	0	124	119
<b>RES share Other Sectors</b>	<b>81%</b>	<b>79%</b>	<b>80%</b>	<b>84%</b>	<b>92%</b>	<b>100%</b>
<b>Total RES</b>	<b>12,671</b>	<b>13,482</b>	<b>14,184</b>	<b>1</b>		

**Table 13.5.22: Africa: Investments in electricity generation**

REF	UNIT	2012-2020	2021-2030	2031-2040	2041-2050	2012-2050	UNIT	ANNUAL AVERAGE 2012-2050
Fossil (w/o CHP)	billion \$	91.9	90.7	142.3	142.5	467.3	billion \$/a	12.0
Nuclear	billion \$	1.8	8.3	10.4	14.9	35.4	billion \$/a	0.9
CHP (fossil + renewable)	billion \$	2.1	7.9	7.7	10.1	27.9	billion \$/a	0.7
Renewables (w/o CHP)	billion \$	78.0	129.6	189.2	262.0	658.9	billion \$/a	16.9
<b>Total</b>	<b>billion \$</b>	<b>173.8</b>	<b>236.5</b>	<b>349.7</b>	<b>429.5</b>	<b>1,189.4</b>	<b>billion \$/a</b>	<b>30.5</b>
Conventional (fossil & nuclear)	billion \$	95.5	105.5	158.8	164.7	524.5	billion \$/a	13.4
Renewables	billion \$	78.3	131.0	190.9	264.7	664.9	billion \$/a	17.0
Biomass	billion \$	3.9	7.7	11.1	17.4	40.1	billion \$/a	1.0
Hydro	billion \$	39.5	62.2	73.1	91.7	266.4	billion \$/a	6.8
Wind	billion \$	6.3	10.6	17.1	26.3	60.3	billion \$/a	1.5
PV	billion \$	11.9	19.3	26.1	34.2	91.5	billion \$/a	2.3
Geothermal	billion \$	11.7	18.4	32.5	52.5	115.0	billion \$/a	2.9
Solar thermal power plants	billion \$	5.1	12.8	30.9	42.7	91.5	billion \$/a	2.3
Ocean energy	billion \$	0.0	0.0	0.0	0.0	0.0	billion \$/a	0.0
<b>E[R]</b>								
Fossil (w/o CHP)	billion \$	61.1	25.3	49.8	34.0	170.2	billion \$/a	4.4
Nuclear	billion \$	1.0	0.0	0.0	0.0	1.0	billion \$/a	0.0
CHP (fossil + renewable)	billion \$	8.5	66.3	24.7	39.0	138.5	billion \$/a	3.6
Renewables (w/o CHP)	billion \$	157.5	585.9	1,011.6	1,349.9	3,104.9	billion \$/a	79.6
<b>Total</b>	<b>billion \$</b>	<b>228.0</b>	<b>677.5</b>	<b>1,086.1</b>	<b>1,422.9</b>	<b>3,414.5</b>	<b>billion \$/a</b>	<b>87.6</b>
Conventional (fossil & nuclear)	billion \$	67.5	72.9	67.4	53.8	261.7	billion \$/a	6.7
Renewables	billion \$	160.6	604.6	1,018.7	1,369.0	3,152.9	billion \$/a	80.8
Biomass	billion \$	8.7	19.8	12.9	22.9	64.3	billion \$/a	1.6
Hydro	billion \$	30.3	24.4	23.3	23.2	101.2	billion \$/a	2.6
Wind	billion \$	32.7	161.9	258.0	339.9	792.5	billion \$/a	20.3
PV	billion \$	48.1	194.5	279.5	308.3	830.4	billion \$/a	21.3
Geothermal	billion \$	11.6	60.6	58.6	76.4	207.3	billion \$/a	5.3
Solar thermal power plants	billion \$	29.2	98.9	330.3	533.2	991.5	billion \$/a	25.4
Ocean energy	billion \$	0.0	44.6	56.1	65.0	165.7	billion \$/a	4.2
<b>ADV E[R]</b>								
Fossil (w/o CHP)	billion \$	57.0	16.2	70.9	64.4	208.4	billion \$/a	5.3
Nuclear	billion \$	1.0	0.0	0.0	0.0	1.0	billion \$/a	0.0
CHP (fossil + renewable)	billion \$	8.5	66.3	23.0	38.0	135.8	billion \$/a	3.5
Renewables (w/o CHP)	billion \$	175.1	779.1	1,624.7	1,968.7	4,547.6	billion \$/a	116.6
<b>Total</b>	<b>billion \$</b>	<b>241.5</b>	<b>861.6</b>	<b>1,718.5</b>	<b>2,071.1</b>	<b>4,892.8</b>	<b>billion \$/a</b>	<b>125.5</b>
Conventional (fossil & nuclear)	billion \$	63.3	63.8	83.3	78.5	288.9	billion \$/a	7.4
Renewables	billion \$	178.2	797.8	1,635.2	1,992.6	4,603.8	billion \$/a	118.0
Biomass	billion \$	11.0	22.1	23.1	37.2	93.4	billion \$/a	2.4
Hydro	billion \$	30.3	24.4	23.3	23.2	101.2	billion \$/a	2.6
Wind	billion \$	41.7	191.5	420.1	505.6	1,158.9	billion \$/a	29.7
PV	billion \$	54.5	283.4	387.5	363.8	1,089.2	billion \$/a	27.9
Geothermal	billion \$	11.6	60.6	57.6	73.2	203.1	billion \$/a	5.2
Solar thermal power plants	billion \$	29.2	171.1	602.9	876.8	1,680.0	billion \$/a	43.1
Ocean energy	billion \$	0.0	44.6	120.7	112.8	278.0	billion \$/a	7.1

**Table 13.5.23: Africa: Investments in renewable heat generation**

REF	UNIT	2012-2020	2021-2030	2031-2040	2041-2050	2012-2050	UNIT	ANNUAL AVERAGE 2012-2050
Heat pumps	billion \$	0.0	0.0	0.0	0.0	0.0	billion \$/a	0.0
Deep geothermal	billion \$	0.0	0.0	0.0	0.0	0.0	billion \$/a	0.0
Solar thermal	billion \$	1.0	2.0	4.4	6.2	13.6	billion \$/a	0.3
Biomass	billion \$	302.6	261.0	58.5	55.7	697.9	billion \$/a	17.9
<b>Total</b>	<b>billion \$</b>	<b>303.6</b>	<b>283.0</b>	<b>62.8</b>	<b>62.0</b>	<b>711.4</b>	<b>billion \$/a</b>	<b>18.2</b>
<b>E[R]</b>								
Heat pumps	billion \$	0.8	21.3	50.9	87.8	160.9	billion \$/a	4.1
Deep geothermal	billion \$	5.5	13.3	13.6	20.4	52.9	billion \$/a	1.4
Solar thermal	billion \$	2.9	38.6	66.6	98.7	206.9	billion \$/a	5.3
Biomass	billion \$	137.7	22.8	13.4	13.2	187.1	billion \$/a	4.8
<b>Total</b>	<b>billion \$</b>	<b>147.0</b>	<b>96.1</b>	<b>144.6</b>	<b>220.1</b>	<b>607.7</b>	<b>billion \$/a</b>	<b>15.6</b>
<b>ADV E[R]</b>								
Heat pumps	billion \$	0.8	21.3	50.8	86.9	159.9	billion \$/a	4.1
Deep geothermal	billion \$	5.5	13.3	13.5	19.5	51.9	billion \$/a	1.3
Solar thermal	billion \$	2.9	38.6	66.3	96.3	204.2	billion \$/a	5.2
Biomass	billion \$	137.7	22.8	13.1	11.6	185.2	billion \$/a	4.7
<b>Total</b>	<b>billion \$</b>	<b>147.0</b>	<b>96.1</b>	<b>143.8</b>	<b>214.3</b>	<b>601.1</b>	<b>billion \$/a</b>	<b>15.4</b>

**Table 13.5.24: Africa Total employment in the energy sector**

By sector	REFERENCE SCENARIO				ADV E[R] SCENARIO		
	2015	2020	2025	2030	2020	2025	2030
Construction and installation	366	442	422	455	937	1,825	2,150
Manufacturing	161	179	176	197	221	534	832
Operations and maintenance	235	308	384	413	453	787	1,213
Fuel supply (domestic)	6,315	6,930	7,313	7,668	6,174	5,900	5,298
Coal and gas export	39.6	46.5	53.2	59.8	25.4	17.9	10.5
Solar and geothermal heat	18.9	18.9	35.2	30	106	404	1,025
<b>Total jobs (thousands)</b>	<b>7,134</b>	<b>7,925</b>	<b>8,383</b>	<b>8,823</b>	<b>7,918</b>	<b>9,468</b>	<b>10,528</b>
<b>By technology</b>							
Coal	376	391	391	420	111	79	42
Gas, oil & diesel	223	247	263	278	171	183	169
Nuclear	16	23	27	29	8	9	8
<b>Renewable</b>	<b>6,521</b>	<b>7,264</b>	<b>7,702</b>	<b>8,096</b>	<b>7,628</b>	<b>9,197</b>	<b>10,309</b>
Biomass	6,244	6,871	7,254	7,601	6,228	5,994	5,408
Hydro	158	209	216	229	98	99	86
Wind	19	28	36	42	295	588	1,005
PV	66	109	126	138	751	1,709	2,058
Geothermal power	6.9	10.1	10.7	15.1	17	37	36
Solar thermal power	8.1	17.4	24.1	42.3	89	294	609
Ocean	-	-	-	-	43	71	82
Solar - heat	18.9	18.9	35.2	30	80	351	932
Geothermal & heat pump	0.0	-	-	-	26.4	53.0	93
<b>Total jobs (thousands)</b>	<b>7,134</b>	<b>7,925</b>	<b>8,383</b>	<b>8,823</b>	<b>7,918</b>	<b>9,468</b>	<b>10,528</b>

# MIDDLE EAST: REFERENCE SCENARIO

Table 13.6.1 Middle East: Electricity generation TWh/a

	2012	2020	2025	2030	2040	2050
<b>Power plants</b>	<b>904</b>	<b>1,204</b>	<b>1,430</b>	<b>1,655</b>	<b>2,093</b>	<b>2,477</b>
Hard coal (& non-renewable waste)	1	3	5	6	7	9
Lignite	0	0	0	0	0	0
Gas	552	809	1,013	1,216	1,585	1,842
<i>of which from H<sup>1</sup></i>	0	0	0	0	0	0
Oil	275	260	219	182	140	101
Diesel	53	72	94	113	133	153
Nuclear	2	20	36	53	66	82
Biomass (& renewable waste)	0	3	5	8	20	40
Hydro	22	28	33	37	43	50
Wind	0	2	7	12	44	106
<i>of which wind offshore</i>	0	0	0	0	4	13
PV	0	4	10	15	31	57
Geothermal	0	0	0	0	0	0
Solar thermal power plants	0	4	9	13	23	36
Ocean energy	0	0	0	0	0	0
<b>Combined heat and power plants</b>	<b>0</b>	<b>1</b>	<b>2</b>	<b>5</b>	<b>10</b>	<b>15</b>
Hard coal (& non-renewable waste)	0	0	0	0	0	0
Lignite	0	0	0	0	0	0
Gas	0	0	1	3	5	8
<i>of which from H<sup>1</sup></i>	0	0	0	0	0	0
Oil	0	0	1	2	3	5
Biomass (& renewable waste)	0	0	0	1	1	2
Geothermal	0	0	0	0	0	0
Hydrogen	0	0	0	0	0	0
<b>CHP by producer</b>						
Main activity producers	0	0	0	0	0	0
Autoproducers	0	1	2	5	10	15
<b>Total generation</b>	<b>904</b>	<b>1,205</b>	<b>1,432</b>	<b>1,660</b>	<b>2,103</b>	<b>2,492</b>
Fossil	880	1,143	1,332	1,521	1,874	2,118
Hard coal (& non-renewable waste)	1	3	5	6	7	9
Lignite	0	0	0	0	0	0
Gas	552	809	1,014	1,218	1,590	1,850
Oil	275	260	220	183	144	106
Diesel	53	72	94	113	133	153
Nuclear	2	20	36	53	66	82
Hydrogen	0	0	0	0	0	0
<i>of which renewable H<sup>1</sup></i>	0	0	0	0	0	0
<b>Renewables (w/o renewable hydrogen)</b>	<b>22</b>	<b>41</b>	<b>64</b>	<b>87</b>	<b>162</b>	<b>292</b>
Hydro	22	28	33	37	43	50
Wind	0	2	7	12	44	106
PV	0	4	10	15	31	57
Biomass (& renewable waste)	0	3	6	8	21	42
Geothermal	0	0	0	0	0	0
Solar thermal power plants	0	4	9	13	23	36
Ocean energy	0	0	0	0	0	0
Distribution losses	116	155	185	216	276	330
Own consumption electricity	56	75	81	87	88	88
Electricity for hydrogen production	0	0	0	0	0	0
Electricity for synfuel production	0	0	0	0	0	0
<b>Final energy consumption (electricity)</b>	<b>734</b>	<b>977</b>	<b>1,168</b>	<b>1,360</b>	<b>1,741</b>	<b>2,078</b>
Fluctuating RES (PV, Wind, Ocean)	0	7	17	28	75	163
Share of fluctuating RES	0%	1%	1%	2%	4%	7%
<b>RES share (domestic generation)</b>	<b>2%</b>	<b>3%</b>	<b>4%</b>	<b>5%</b>	<b>8%</b>	<b>12%</b>

Table 13.6.2 Middle East: Final energy consumption in transport PJ/a

	2012	2020	2025	2030	2040	2050
<b>Road</b>	<b>5,226</b>	<b>6,835</b>	<b>8,197</b>	<b>9,565</b>	<b>11,673</b>	<b>12,486</b>
Fossil fuels	4,981	6,545	7,853	9,167	11,166	11,847
Biofuels	0	0	0	0	0	0
Synfuels	0	0	0	0	0	0
Natural gas	245	290	344	398	507	638
Hydrogen	0	0	0	0	0	0
Electricity	0	0	0	0	0	0
<b>Rail</b>	<b>2</b>	<b>2</b>	<b>2</b>	<b>2</b>	<b>2</b>	<b>2</b>
Fossil fuels	1	1	1	1	1	1
Biofuels	0	0	0	0	0	0
Synfuels	0	0	0	0	0	0
Electricity	1	1	1	1	1	1
<b>Navigation</b>	<b>0</b>	<b>0</b>	<b>0</b>	<b>0</b>	<b>0</b>	<b>0</b>
Fossil fuels	0	0	0	0	0	0
Biofuels	0	0	0	0	0	0
Synfuels	0	0	0	0	0	0
<b>Aviation</b>	<b>46</b>	<b>62</b>	<b>76</b>	<b>84</b>	<b>116</b>	<b>154</b>
Fossil fuels	46	62	76	84	116	154
Biofuels	0	0	0	0	0	0
Synfuels	0	0	0	0	0	0
<b>Total (incl. pipelines)</b>	<b>5,293</b>	<b>6,923</b>	<b>8,301</b>	<b>9,679</b>	<b>11,825</b>	<b>12,680</b>
Fossil fuels	5,028	6,608	7,990	9,252	11,283	12,002
Biofuels (incl. biogas)	0	0	0	0	0	0
Synfuels	0	0	0	0	0	0
Natural gas	263	313	369	425	540	676
Hydrogen	0	0	0	0	0	0
Electricity	1	1	1	1	1	2
<b>Total RES</b>	<b>0</b>	<b>0</b>	<b>0</b>	<b>0</b>	<b>0</b>	<b>0</b>
<b>RES share</b>	<b>0%</b>	<b>0%</b>	<b>0%</b>	<b>0%</b>	<b>0%</b>	<b>0%</b>

Table 13.6.3 Middle East: Heat supply PJ/a

	2012	2020	2025	2030	2040	2050
<b>District heating plants</b>	<b>0</b>	<b>0</b>	<b>0</b>	<b>0</b>	<b>0</b>	<b>0</b>
Fossil fuels	0	0	0	0	0	0
Biomass	0	0	0	0	0	0
Solar collectors	0	0	0	0	0	0
Geothermal	0	0	0	0	0	0
<b>Heat from CHP<sup>1</sup></b>	<b>0</b>	<b>1</b>	<b>6</b>	<b>15</b>	<b>33</b>	<b>60</b>
Fossil fuels	0	1	5	13	28	44
Biomass	0	0	0	1	5	15
Geothermal	0	0	0	0	0	0
Hydrogen	0	0	0	0	0	0
<b>Direct heating</b>	<b>6,409</b>	<b>7,590</b>	<b>8,725</b>	<b>9,907</b>	<b>12,991</b>	<b>15,205</b>
Fossil fuels	5,938	6,969	7,984	9,046	11,771	13,649
Biomass	20	76	131	186	345	554
Solar collectors	7	25	40	55	94	149
Geothermal	0	0	0	0	0	0
Heat pumps <sup>2</sup>	0	0	0	0	0	0
Electric direct heating	445	520	570	620	780	852
Hydrogen	0	0	0	0	0	0
<b>Total heat supply<sup>3</sup></b>	<b>6,409</b>	<b>7,591</b>	<b>8,731</b>	<b>9,922</b>	<b>13,024</b>	<b>15,265</b>
Fossil fuels	5,938	6,970	7,990	9,059	11,799	13,693
Biomass	20	76	131	188	350	569
Solar collectors	7	25	40	55	94	149
Geothermal	0	0	0	0	0	0
Heat pumps <sup>2</sup>	0	0	0	0	0	0
Electric direct heating	445	520	570	620	780	852
Hydrogen	0	0	0	0	0	0
<b>RES share (including RES electricity)</b>	<b>1%</b>	<b>2%</b>	<b>2%</b>	<b>3%</b>	<b>4%</b>	<b>5%</b>

<sup>1</sup> public CHP and CHP autoproduction / <sup>2</sup> heat from ambient energy and electricity use / <sup>3</sup> incl. process heat, cooking

Table 13.6.4: Middle East: Installed capacity GW

	2012	2020	2025	2030	2040	2050
<b>Total generation</b>	<b>256</b>	<b>343</b>	<b>387</b>	<b>431</b>	<b>508</b>	<b>593</b>
<b>Fossil</b>	<b>241</b>	<b>315</b>	<b>347</b>	<b>379</b>	<b>424</b>	<b>458</b>
Hard coal (& non-renewable waste)	0	0	0	0	0	0
Lignite	0	0	0	0	0	0
Gas (w/o H <sup>1</sup> )	166	226	261	296	344	381
Oil	62	69	60	51	41	30
Diesel	12	19	25	31	38	44
Nuclear	1	3	5	8	9	11
Hydrogen (fuel cells, gas power plants, gas CHP)	0	0	0	0	0	0
<b>Renewables</b>	<b>15</b>	<b>24</b>	<b>34</b>	<b>44</b>	<b>75</b>	<b>124</b>
Hydro	14	18	21	23	26	30
Wind	0	0	3	5	19	45
<i>of which wind offshore</i>	0	0	0	0	1	4
PV	0	3	6	9	19	35
Biomass (& renewable waste)	0	0	1	1	3	7
Geothermal	0	0	0	0	0	0
Solar thermal power plants	0	2	3	5	8	7
Ocean energy	0	0	0	0	0	0
Fluctuating RES (PV, Wind, Ocean)	0	4	9	15	38	80
Share of fluctuating RES	0%	1%	2%	3%	7%	14%
<b>RES share (domestic generation)</b>	<b>6%</b>	<b>7%</b>	<b>9%</b>	<b>10%</b>	<b>15%</b>	<b>21%</b>

Table 13.6.5: Middle East: Final energy demand PJ/a

	2012	2020	2025	2030	2040	2050
<b>Total (incl. non-energy use)</b>	<b>18,967</b>	<b>23,152</b>	<b>26,825</b>	<b>30,499</b>	<b>37,962</b>	<b>43,112</b>
<b>Total energy use</b>	<b>15,306</b>	<b>18,950</b>	<b>22,152</b>	<b>25,366</b>	<b>31,728</b>	<b>35,791</b>
<b>Transport</b>	<b>5,293</b>	<b>6,923</b>	<b>8,301</b>	<b>9,679</b>	<b>11,825</b>	<b>12,680</b>
Oil products	5,028	6,608	7,990	9,252	11,283	12,002
Natural gas	263	313	369	425	540	676
Biofuels	0	0	0	0	0	0
Synfuels	0	0	0	0	0	0
Electricity	1	1	1	1	1	2
RES electricity	0	0	0	0	0	0
Hydrogen	0	0	0	0	0	0
<b>RES share Transport</b>	<b>0%</b>	<b>0%</b>	<b>0%</b>	<b>0%</b>	<b>0%</b>	<b>0%</b>
<b>Industry</b>	<b>5,271</b>	<b>6,112</b>	<b>7,122</b>	<b>8,132</b>	<b>10,595</b>	<b>12,483</b>
Electricity	578	734	835	936	1,175	1,463
RES electricity	14	25	37	49	91	171
Public district heat	0	0	0	0	0	0
RES district heat	0	0	0	0	0	0
Hard coal & lignite	79	90	87	84	88	35
Oil products	1,453	1,551	1,675	1,798	2,012	2,013
Gas	3,162	3,672	4,395	5,118	6,953	8,404
Solar	0	1	3	4	7	10
Biomass	0	64	128	192	360	557
Geothermal	0	0	0	0	0	0
Hydrogen	0	0	0	0	0	0
<b>RES share Industry</b>	<b>0%</b>	<b>1%</b>	<b>2%</b>	<b>3%</b>	<b>4%</b>	<b>6%</b>
<b>Other Sectors</b>	<b>4,742</b>	<b>5,915</b>	<b>6,729</b>	<b>7,554</b>	<b>9,308</b>	<b>10,628</b>
<b>Electricity</b>	<b>2,064</b>	<b>2,781</b>	<b>3,370</b>	<b>3,959</b>	<b>5,092</b>	<b>6,014</b>
RES electricity	51	95	151	207	383	705
Public district heat	0	0	0	0	0	0
RES district heat	0	0	0	0	0	0
Hard coal & lignite	0	0	0	0	0	0
Oil products	970	995	993	1,001	1,003	962
Gas	1,670	2,072	2,276	2,481	3,040	3,401
Solar	7	24	37	51	87	140



**Table 13.6.8 Middle East: Electricity generation TWh/a**

	2012	2020	2025	2030	2040	2050
<b>Power plants</b>	<b>904</b>	<b>1,119</b>	<b>1,263</b>	<b>1,596</b>	<b>2,413</b>	<b>3,400</b>
Hard coal (& non-renewable waste)	1	0	0	0	0	0
Lignite	0	0	0	0	0	0
Gas	552	730	721	699	541	229
<i>of which from H<sub>2</sub></i>	0	0	0	0	0	0
Oil	275	189	132	58	4	2
Diesel	53	45	25	15	1	0
Nuclear	2	3	3	3	3	3
Biomass (& renewable waste)	0	5	8	14	15	18
Hydro	22	28	33	37	43	50
Wind	0	35	105	190	302	439
<i>of which wind offshore</i>	0	0	10	15	25	40
Geothermal	0	1	10	35	77	66
Solar thermal power plants	0	25	95	280	809	1,473
Ocean energy	0	3	13	14	23	51
<b>Combined heat and power plants</b>	<b>0</b>	<b>15</b>	<b>25</b>	<b>30</b>	<b>55</b>	<b>85</b>
Hard coal (& non-renewable waste)	0	0	0	0	0	0
Lignite	0	0	0	0	0	0
Gas	0	3	5	5	7	11
<i>of which from H<sub>2</sub></i>	0	0	0	0	0	0
Oil	0	1	1	1	1	1
Biomass (& renewable waste)	0	7	12	14	23	27
Geothermal	0	3	6	9	22	38
Hydrogen	0	0	1	1	3	9
<b>CHP by producer</b>						
Main activity producers	0	0	0	0	0	0
Autoproducers	0	15	25	30	55	85
<b>Total generation</b>	<b>904</b>	<b>1,134</b>	<b>1,288</b>	<b>1,626</b>	<b>2,468</b>	<b>3,485</b>
Fossil	880	969	884	778	563	242
Hard coal (& non-renewable waste)	1	0	0	0	0	0
Lignite	0	0	0	0	0	0
Gas	552	733	725	704	548	240
Oil	275	190	134	59	4	2
Diesel	53	45	25	15	1	0
Nuclear	2	3	3	3	3	3
Hydrogen	0	0	1	1	3	9
<i>of which renewable H<sub>2</sub></i>	0	0	0	1	2	8
<b>Renewables (w/o renewable hydrogen)</b>	<b>22</b>	<b>162</b>	<b>401</b>	<b>843</b>	<b>1,913</b>	<b>3,234</b>
Hydro	22	28	33	37	43	50
Wind	0	35	105	190	302	439
PV	0	55	120	250	589	1,072
Biomass (& renewable waste)	0	12	20	28	38	45
Geothermal	0	4	16	44	99	105
Solar thermal power plants	0	25	95	280	809	1,473
Ocean energy	0	3	13	14	23	51
Distribution losses	116	141	153	165	192	212
Own consumption electricity	56	60	57	54	49	44
Electricity for hydrogen production	0	1	5	62	344	709
Electricity for synfuel production	0	0	0	0	0	0
<b>Final energy consumption (electricity)</b>	<b>734</b>	<b>932</b>	<b>1,068</b>	<b>1,317</b>	<b>1,823</b>	<b>2,440</b>
Fluctuating RES (PV, Wind, Ocean)	0	93	238	454	924	1,562
Share of fluctuating RES	0%	8%	18%	28%	37%	45%
<b>RES share (domestic generation)</b>	<b>2%</b>	<b>14%</b>	<b>31%</b>	<b>52%</b>	<b>78%</b>	<b>93%</b>

**Table 13.6.9 Middle East: Final energy consumption in transport PJ/a**

	2012	2020	2025	2030	2040	2050
<b>Road</b>	<b>5,226</b>	<b>6,717</b>	<b>6,613</b>	<b>6,515</b>	<b>5,787</b>	<b>5,053</b>
Fossil fuels	4,981	6,291	5,873	5,091	2,847	524
Biofuels	0	128	309	443	502	524
Synfuels	0	0	0	0	0	0
Natural gas	245	269	278	326	322	331
Hydrogen	0	0	7	148	874	1,597
Electricity	0	29	146	508	1,242	2,077
<b>Rail</b>	<b>2</b>	<b>3</b>	<b>3</b>	<b>4</b>	<b>3</b>	<b>5</b>
Fossil fuels	1	1	1	1	1	0
Biofuels	0	0	0	0	0	0
Synfuels	0	0	0	0	0	0
Electricity	1	2	2	2	3	5
<b>Navigation</b>	<b>0</b>	<b>0</b>	<b>0</b>	<b>0</b>	<b>0</b>	<b>0</b>
Fossil fuels	0	0	0	0	0	0
Biofuels	0	0	0	0	0	0
Synfuels	0	0	0	0	0	0
<b>Aviation</b>	<b>46</b>	<b>53</b>	<b>62</b>	<b>65</b>	<b>80</b>	<b>85</b>
Fossil fuels	46	53	60	61	71	51
Biofuels	0	0	1	4	10	34
Synfuels	0	0	0	0	0	0
<b>Total (incl. pipelines)</b>	<b>5,293</b>	<b>6,792</b>	<b>6,696</b>	<b>6,600</b>	<b>5,885</b>	<b>5,150</b>
Fossil fuels	5,028	6,346	5,935	5,153	2,918	575
Biofuels (incl. biogas)	0	128	310	447	512	558
Synfuels	0	0	0	0	0	0
Natural gas	263	288	295	342	333	335
Hydrogen	0	0	7	148	874	1,597
Electricity	1	30	149	511	1,248	2,085
<b>Total RES</b>	<b>0</b>	<b>133</b>	<b>359</b>	<b>789</b>	<b>2,158</b>	<b>3,984</b>
<b>RES share</b>	<b>0%</b>	<b>2%</b>	<b>5%</b>	<b>12%</b>	<b>37%</b>	<b>77%</b>

**Table 13.6.10 Middle East: Heat supply PJ/a**

	2012	2020	2025	2030	2040	2050
<b>District heating plants</b>	<b>0</b>	<b>0</b>	<b>0</b>	<b>0</b>	<b>0</b>	<b>0</b>
Fossil fuels	0	0	0	0	0	0
Biomass	0	0	0	0	0	0
Solar collectors	0	0	0	0	0	0
Geothermal	0	0	0	0	0	0
<b>Heat from CHP<sup>1</sup></b>	<b>0</b>	<b>57</b>	<b>107</b>	<b>146</b>	<b>333</b>	<b>631</b>
Fossil fuels	0	12	17	18	24	40
Biomass	0	17	31	41	95	196
Geothermal	0	27	56	81	198	344
Hydrogen	0	1	3	6	17	51
<b>Direct heating</b>	<b>6,409</b>	<b>7,242</b>	<b>7,400</b>	<b>7,603</b>	<b>8,024</b>	<b>8,030</b>
Fossil fuels	5,938	6,138	5,879	5,391	3,888	1,633
Biomass	20	98	121	146	207	315
Solar collectors	7	159	370	733	1,609	2,020
Geothermal	0	110	144	180	231	366
Heat pumps <sup>2</sup>	0	53	87	122	293	577
Electric direct heating	445	684	798	1,031	1,796	2,858
Hydrogen	0	0	0	0	0	261
<b>Total heat supply<sup>3</sup></b>	<b>6,409</b>	<b>7,299</b>	<b>7,507</b>	<b>7,749</b>	<b>8,357</b>	<b>8,661</b>
Fossil fuels	5,938	6,150	5,896	5,408	3,912	1,673
Biomass	20	115	152	187	302	511
Solar collectors	7	159	370	733	1,609	2,020
Geothermal	0	137	200	261	429	710
Heat pumps <sup>2</sup>	0	53	87	122	293	577
Electric direct heating	445	684	798	1,031	1,796	2,858
Hydrogen	0	1	3	6	17	51
<b>RES share (including RES electricity)</b>	<b>1%</b>	<b>8%</b>	<b>14%</b>	<b>24%</b>	<b>49%</b>	<b>78%</b>

<sup>1</sup> public CHP and CHP autoproduction / <sup>2</sup> heat from ambient energy and electricity use / <sup>3</sup> incl. process heat, cooking

**Table 13.6.10 Middle East: Installed capacity GW**

	2012	2020	2025	2030	2040	2050
<b>Total generation</b>	<b>256</b>	<b>352</b>	<b>416</b>	<b>572</b>	<b>923</b>	<b>1,392</b>
<b>Fossil</b>	<b>241</b>	<b>268</b>	<b>230</b>	<b>211</b>	<b>204</b>	<b>222</b>
Hard coal (& non-renewable waste)	0	0	0	0	0	0
Lignite	0	0	0	0	0	0
Gas (w/o H <sub>2</sub> )	166	205	187	190	202	220
Oil	62	51	36	16	1	1
Diesel	12	12	7	4	0	0
Nuclear	0	1	0	0	0	0
Hydrogen (fuel cells, gas power plants, gas CHP)	0	0	0	0	1	2
<b>Renewables</b>	<b>15</b>	<b>83</b>	<b>186</b>	<b>360</b>	<b>719</b>	<b>1,168</b>
Hydro	14	18	21	23	26	30
Wind	0	16	45	82	130	188
<i>of which wind offshore</i>	0	0	3	5	9	13
PV	0	34	73	151	358	656
Biomass (& renewable waste)	0	2	3	5	7	9
Geothermal	0	1	2	6	14	15
Solar thermal power plants	0	10	35	86	167	245
Ocean energy	0	2	6	7	17	26
Fluctuating RES (PV, Wind, Ocean)	0	52	125	240	505	870
Share of fluctuating RES	0%	15%	30%	42%	55%	62%
<b>RES share (domestic generation)</b>	<b>6%</b>	<b>24%</b>	<b>45%</b>	<b>63%</b>	<b>78%</b>	<b>84%</b>

**Table 13.6.12 Middle East: Final energy demand PJ/a**

	2012	2020	2025	2030	2040	2050
<b>Total (incl. non-energy use)</b>	<b>18,967</b>	<b>21,530</b>	<b>21,950</b>	<b>22,433</b>	<b>22,228</b>	<b>21,212</b>
<b>Total energy use</b>	<b>15,306</b>	<b>17,981</b>	<b>18,119</b>	<b>18,320</b>	<b>17,918</b>	<b>17,203</b>
<b>Transport</b>	<b>5,293</b>	<b>6,792</b>	<b>6,696</b>	<b>6,600</b>	<b>5,885</b>	<b>5,150</b>
Oil products	5,028	6,346	5,935	5,153	2,918	575
Natural gas	263	288	295	342	333	335
Biofuels	0	128	310	447	512	558
Synfuels	0	0	0	0	0	0
Electricity	1	30	149	511	1,248	2,085
RES electricity	0	4	46	265	968	1,940
Hydrogen	0	0	7	148	874	1,597
<b>RES share Transport</b>	<b>0%</b>	<b>2%</b>	<b>5%</b>	<b>12%</b>	<b>37%</b>	<b>77%</b>
<b>Industry</b>	<b>5,271</b>	<b>5,677</b>	<b>5,628</b>	<b>5,615</b>	<b>5,634</b>	<b>5,607</b>
Electricity	578	772	846	1,010	1,476	2,282
RES electricity	14	110	264	524	1,145	2,124
Public district heat	0	0	0	0	0	0
RES district heat	0	0	0	0	0	0
Hard coal & lignite	79	41	49	44	0	0
Oil products	1,453	1,133	859	620	248	61
Gas	3,162	3,450	3,381	3,168	2,606	1,161
Solar	0	88	222	422	756	984
Biomass	0	64	92	120	176	272
Geothermal	0	129	179	231	373	572
Hydrogen	0	0	0	0	0	275
<b>RES share Industry</b>	<b>0%</b>	<b>7%</b>	<b>13%</b>	<b>23%</b>	<b>43%</b>	<b>75%</b>
<b>Other Sectors</b>	<b>4,742</b>	<b>5,512</b>	<b>5,795</b>	<b>6,105</b>	<b>6,398</b>	<b>6,446</b>
Electricity	2,064	2,551	2,851	3,221	3,840	4,417
RES electricity	51	364	888	1,672	2,979	4,109
Public district heat	0	0	0	0	0	0
RES district heat						

# MIDDLE EAST: ADVANCED ENERGY [R]EVOLUTION SCENARIO

Table 13.6.15 Middle East: Electricity generation TWh/a

	2012	2020	2025	2030	2040	2050
<b>Power plants</b>	<b>904</b>	<b>1,127</b>	<b>1,318</b>	<b>1,798</b>	<b>3,007</b>	<b>4,621</b>
Hard coal (& non-renewable waste)	1	0	0	0	0	0
Lignite	0	0	0	0	0	0
Gas	552	721	677	661	367	139
of which from H <sub>2</sub>	0	0	0	0	18	139
Oil	275	189	132	48	2	0
Diesel	53	45	25	15	0	0
Nuclear	0	0	0	0	0	0
Biomass (& renewable waste)	0	5	13	14	15	18
Hydro	22	28	36	37	43	50
Wind	0	45	135	248	533	664
of which wind offshore	0	0	10	15	45	65
Geothermal	0	9	25	35	77	116
Solar thermal power plants	0	25	105	355	1,174	2,362
Ocean energy	0	3	13	14	59	92
<b>Combined heat and power plants</b>	<b>0</b>	<b>15</b>	<b>25</b>	<b>30</b>	<b>55</b>	<b>85</b>
Hard coal (& non-renewable waste)	0	0	0	0	0	0
Lignite	0	0	0	0	0	0
Gas	0	3	5	5	7	11
of which from H <sub>2</sub>	0	0	0	0	0	11
Oil	0	1	1	1	0	0
Biomass (& renewable waste)	0	7	12	14	23	27
Geothermal	0	3	6	9	22	38
Hydrogen	0	0	1	1	3	9
<b>CHP by producer</b>						
Main activity producers	0	0	0	0	0	0
Autoproducers	0	15	25	30	55	85
<b>Total generation</b>	<b>904</b>	<b>1,142</b>	<b>1,343</b>	<b>1,828</b>	<b>3,062</b>	<b>4,706</b>
Fossil	880	959	840	730	357	0
Hard coal (& non-renewable waste)	1	0	0	0	0	0
Lignite	0	0	0	0	0	0
Gas	552	724	681	666	355	0
Oil	275	190	134	49	2	0
Diesel	53	45	25	15	0	0
Nuclear	2	3	3	3	0	0
Hydrogen	0	0	1	1	21	159
of which renewable H <sub>2</sub>	0	0	0	1	19	158
<b>Renewables (w/o renewable hydrogen)</b>	<b>22</b>	<b>180</b>	<b>499</b>	<b>1,094</b>	<b>2,683</b>	<b>4,547</b>
Hydro	22	28	36	37	43	50
Wind	0	45	135	248	533	664
PV	0	55	155	368	737	1,180
Biomass (& renewable waste)	0	12	25	28	38	45
Geothermal	0	12	31	44	99	155
Solar thermal power plants	0	25	105	355	1,174	2,362
Ocean energy	0	3	13	14	59	92
Distribution losses	116	141	163	165	192	212
Own consumption electricity	56	60	57	54	49	44
Electricity for hydrogen production	0	1	22	154	627	1,517
Electricity for synfuel production	0	0	0	0	107	59
<b>Final energy consumption (electricity)</b>	<b>734</b>	<b>940</b>	<b>1,105</b>	<b>1,424</b>	<b>2,006</b>	<b>2,749</b>
Fluctuating RES (PV, Wind, Ocean)	0	103	303	630	1,329	1,936
Share of fluctuating RES	0%	9%	23%	34%	43%	41%
<b>RES share (domestic generation)</b>	<b>2%</b>	<b>16%</b>	<b>37%</b>	<b>60%</b>	<b>88%</b>	<b>100%</b>

Table 13.6.16 Middle East: Final energy consumption in transport PJ/a

	2012	2020	2025	2030	2040	2050
<b>Road</b>	<b>5,226</b>	<b>6,642</b>	<b>6,356</b>	<b>6,031</b>	<b>4,976</b>	<b>4,469</b>
Fossil fuels	4,981	6,212	5,523	4,336	1,652	0
Biofuels	0	127	291	377	461	417
Synfuels	0	0	0	0	150	81
Natural gas	245	263	252	217	102	0
Hydrogen	0	0	49	382	1,290	1,812
Electricity	0	41	241	719	1,472	2,240
<b>Rail</b>	<b>2</b>	<b>20</b>	<b>44</b>	<b>60</b>	<b>88</b>	<b>89</b>
Fossil fuels	1	1	1	1	0	0
Biofuels	0	0	0	0	0	0
Synfuels	0	0	0	0	0	0
Electricity	1	19	43	59	88	89
<b>Navigation</b>	<b>0</b>	<b>0</b>	<b>0</b>	<b>0</b>	<b>0</b>	<b>0</b>
Fossil fuels	0	0	0	0	0	0
Biofuels	0	0	0	0	0	0
Synfuels	0	0	0	0	0	0
<b>Aviation</b>	<b>46</b>	<b>53</b>	<b>62</b>	<b>65</b>	<b>80</b>	<b>85</b>
Fossil fuels	46	53	61	59	52	0
Biofuels	0	0	0	6	21	71
Synfuels	0	0	0	0	7	14
<b>Total (incl. pipelines)</b>	<b>5,293</b>	<b>6,735</b>	<b>6,479</b>	<b>6,172</b>	<b>5,309</b>	<b>4,731</b>
Fossil fuels	5,028	6,266	5,585	4,396	1,704	0
Biofuels (incl. biogas)	0	127	291	383	482	488
Synfuels	0	0	0	0	157	95
Natural gas	263	281	269	230	104	0
Hydrogen	0	0	49	382	1,290	1,812
Electricity	1	61	285	782	1,572	2,336
<b>Total RES</b>	<b>0</b>	<b>136</b>	<b>416</b>	<b>1,080</b>	<b>3,146</b>	<b>4,731</b>
<b>RES share</b>	<b>0%</b>	<b>2%</b>	<b>6%</b>	<b>17%</b>	<b>59%</b>	<b>100%</b>

Table 13.6.17 Middle East: Heat supply PJ/a

	2012	2020	2025	2030	2040	2050
<b>District heating plants</b>	<b>0</b>	<b>0</b>	<b>0</b>	<b>0</b>	<b>0</b>	<b>0</b>
Fossil fuels	0	0	0	0	0	0
Biomass	0	0	0	0	0	0
Solar collectors	0	0	0	0	0	0
Geothermal	0	0	0	0	0	0
<b>Heat from CHP<sup>1</sup></b>	<b>0</b>	<b>57</b>	<b>107</b>	<b>146</b>	<b>333</b>	<b>631</b>
Fossil fuels	0	12	17	18	23	0
Biomass	0	17	31	41	95	196
Geothermal	0	27	56	81	198	344
Hydrogen	0	1	3	6	18	91
<b>Direct heating</b>	<b>6,409</b>	<b>7,242</b>	<b>7,400</b>	<b>7,603</b>	<b>8,024</b>	<b>8,030</b>
Fossil fuels	5,938	6,138	5,883	5,398	3,718	0
Biomass	20	98	121	146	207	315
Solar collectors	7	159	370	733	1,609	2,386
Geothermal	0	110	144	180	231	366
Heat pumps <sup>2</sup>	0	53	87	122	293	577
Electric direct heating	445	684	794	1,024	1,796	3,219
Hydrogen	0	0	0	0	170	1,167
<b>Total heat supply<sup>3</sup></b>	<b>6,409</b>	<b>7,299</b>	<b>7,507</b>	<b>7,749</b>	<b>8,357</b>	<b>8,661</b>
Fossil fuels	5,938	6,150	5,901	5,415	3,741	0
Biomass	20	115	152	187	302	511
Solar collectors	7	159	370	733	1,609	2,386
Geothermal	0	137	200	261	429	710
Heat pumps <sup>2</sup>	0	53	87	122	293	577
Electric direct heating	445	684	794	1,024	1,796	3,219
Hydrogen	0	1	3	6	188	1,258
<b>RES share (including RES electricity)</b>	<b>1%</b>	<b>8%</b>	<b>15%</b>	<b>25%</b>	<b>53%</b>	<b>100%</b>

<sup>1</sup> public CHP and CHP autoproduction / <sup>2</sup> heat from ambient energy and electricity use / <sup>3</sup> incl. process heat, cooking

Table 13.6.18: Middle East: Installed capacity GW

	2012	2020	2025	2030	2040	2050
<b>Total generation</b>	<b>256</b>	<b>355</b>	<b>463</b>	<b>706</b>	<b>1,203</b>	<b>1,587</b>
<b>Fossil</b>	<b>241</b>	<b>265</b>	<b>233</b>	<b>225</b>	<b>196</b>	<b>0</b>
Hard coal (& non-renewable waste)	0	0	0	0	0	0
Lignite	0	0	0	0	0	0
Gas (w/o H <sub>2</sub> )	166	203	190	208	195	0
Oil	62	51	36	14	0	0
Diesel	12	12	7	4	0	0
Nuclear	0	0	0	0	0	0
Hydrogen (fuel cells, gas power plants, gas CHP)	0	0	0	0	11	82
<b>Renewables</b>	<b>15</b>	<b>89</b>	<b>229</b>	<b>480</b>	<b>996</b>	<b>1,505</b>
Hydro	14	18	23	23	26	30
Wind	0	21	59	107	229	285
of which wind offshore	0	0	3	5	15	22
PV	0	34	94	223	449	722
Biomass (& renewable waste)	0	2	4	5	6	8
Geothermal	0	2	5	6	14	22
Solar thermal power plants	0	10	38	109	242	394
Ocean energy	0	2	6	7	30	46
Fluctuating RES (PV, Wind, Ocean)	0	57	159	337	707	1,052
Share of fluctuating RES	0%	16%	34%	48%	59%	66%
<b>RES share (domestic generation)</b>	<b>6%</b>	<b>25%</b>	<b>49%</b>	<b>68%</b>	<b>83%</b>	<b>95%</b>

Table 13.6.19: Middle East: Final energy demand PJ/a

	2012	2020	2025	2030	2040	2050
<b>Total (incl. non-energy use)</b>	<b>18,967</b>	<b>21,472</b>	<b>21,734</b>	<b>22,095</b>	<b>21,893</b>	<b>21,101</b>
<b>Total energy use</b>	<b>15,306</b>	<b>17,924</b>	<b>17,903</b>	<b>17,981</b>	<b>17,583</b>	<b>17,092</b>
<b>Transport</b>	<b>5,293</b>	<b>6,735</b>	<b>6,479</b>	<b>6,172</b>	<b>5,309</b>	<b>4,731</b>
Oil products	5,028	6,266	5,585	4,396	1,704	0
Natural gas	263	281	269	230	104	0
Biofuels	0	127	291	383	482	488
Synfuels	0	0	0	0	157	95
Electricity	1	61	285	782	1,572	2,336
RES electricity	0	10	106	468	1,387	2,336
Hydrogen	0	0	49	382	1,290	1,812
<b>RES share Transport</b>	<b>0%</b>	<b>2%</b>	<b>6%</b>	<b>17%</b>	<b>59%</b>	<b>100%</b>
<b>Industry</b>	<b>5,271</b>	<b>5,677</b>	<b>5,628</b>	<b>5,653</b>	<b>5,741</b>	<b>5,748</b>
Electricity	578	772	846	1,063	1,624	2,807
RES electricity	14	121	315	637	1,433	2,807
Public district heat	0	0	0	0	0	0
RES district heat	0	0	0	0	0	0
Hard coal & lignite	79	41	49	44	0	0
Oil products	1,453	1,133	859	611	231	0
Gas	3,162	3,450	3,381	3,162	2,453	0
Solar	0	88	222	422	756	1,350
Biomass	0	64	92	120	176	272
Geothermal	0	129	179	231	373	572
Hydrogen	0	0	0	0	128	747
<b>RES share Industry</b>	<b>0%</b>	<b>7%</b>	<b>14%</b>	<b>25%</b>	<b>50%</b>	<b>100%</b>
<b>Other Sectors</b>	<b>4,742</b>	<b>5,512</b>	<b>5,796</b>	<b>6,156</b>	<b>6,533</b>	<b>6,613</b>
Electricity	2,064	2,551	2,846	3,284	4,026	4,754
RES electricity	51	401	1,059	1,967	3,553	4,754
Public district heat	0	0	0	0	0	0
RES district heat	0	0	0	0	0	0
Hard coal & lignite	0					

Table 13.6.22: Middle East: Investments in electricity generation

REF	UNIT	2012-2020	2021-2030	2031-2040	2041-2050	2012-2050	UNIT	ANNUAL AVERAGE 2012-2050
Fossil (w/o CHP)	billion \$	99.3	94.2	155.5	144.7	493.8	billion \$/a	12.7
Nuclear	billion \$	10.4	17.7	7.2	8.6	43.9	billion \$/a	1.1
CHP (fossil + renewable)	billion \$	0.5	3.3	2.8	3.9	10.4	billion \$/a	0.3
Renewables (w/o CHP)	billion \$	40.0	55.5	80.2	108.1	286.9	billion \$/a	7.4
<b>Total</b>	<b>billion \$</b>	<b>150.2</b>	<b>173.7</b>	<b>245.7</b>	<b>265.3</b>	<b>834.9</b>	<b>billion \$/a</b>	<b>21.4</b>
Conventional (fossil & nuclear)	billion \$	110.2	114.9	165.2	156.6	547.0	billion \$/a	14.0
Renewables	billion \$	40.1	58.7	80.5	108.7	288.0	billion \$/a	7.4
Biomass	billion \$	0.9	2.0	5.0	9.0	17.0	billion \$/a	0.4
Hydro	billion \$	21.8	22.6	17.7	20.8	82.8	billion \$/a	2.1
Wind	billion \$	1.6	6.5	22.8	47.8	78.7	billion \$/a	2.0
PV	billion \$	4.8	8.7	12.8	17.4	43.8	billion \$/a	1.1
Geothermal	billion \$	0.0	0.0	0.0	0.0	0.0	billion \$/a	0.0
Solar thermal power plants	billion \$	10.9	19.0	22.1	13.7	65.7	billion \$/a	1.7
Ocean energy	billion \$	0.0	0.0	0.0	0.0	0.0	billion \$/a	0.0
<b>E[R]</b>								
Fossil (w/o CHP)	billion \$	67.5	21.7	99.6	40.2	229.0	billion \$/a	5.9
Nuclear	billion \$	5.1	0.0	0.0	0.0	5.1	billion \$/a	0.1
CHP (fossil + renewable)	billion \$	8.9	5.6	12.3	9.2	36.0	billion \$/a	0.9
Renewables (w/o CHP)	billion \$	183.9	815.1	919.9	1,218.0	3,137.0	billion \$/a	80.4
<b>Total</b>	<b>billion \$</b>	<b>265.4</b>	<b>842.4</b>	<b>1,031.8</b>	<b>1,267.4</b>	<b>3,407.1</b>	<b>billion \$/a</b>	<b>87.4</b>
Conventional (fossil & nuclear)	billion \$	77.6	23.6	102.8	42.1	246.0	billion \$/a	6.3
Renewables	billion \$	187.8	818.8	929.1	1,225.3	3,161.1	billion \$/a	81.1
Biomass	billion \$	5.1	6.4	9.8	10.3	31.5	billion \$/a	0.8
Hydro	billion \$	21.8	22.6	17.7	20.8	82.8	billion \$/a	2.1
Wind	billion \$	25.1	108.8	99.9	190.2	424.1	billion \$/a	10.9
PV	billion \$	59.4	152.4	249.8	316.6	778.2	billion \$/a	20.0
Geothermal	billion \$	0.6	36.8	36.9	5.1	79.4	billion \$/a	2.0
Solar thermal power plants	billion \$	66.6	462.1	479.0	645.5	1,653.2	billion \$/a	42.4
Ocean energy	billion \$	9.2	29.7	36.0	36.8	111.8	billion \$/a	2.9
<b>ADV E[R]</b>								
Fossil (w/o CHP)	billion \$	66.0	33.1	93.4	0.0	192.5	billion \$/a	4.9
Nuclear	billion \$	5.1	0.0	0.0	0.0	5.1	billion \$/a	0.1
CHP (fossil + renewable)	billion \$	8.9	5.6	12.3	9.2	36.0	billion \$/a	0.9
Renewables (w/o CHP)	billion \$	205.1	1,071.5	1,408.5	1,787.4	4,472.5	billion \$/a	114.7
<b>Total</b>	<b>billion \$</b>	<b>285.1</b>	<b>1,110.3</b>	<b>1,514.1</b>	<b>1,796.6</b>	<b>4,706.2</b>	<b>billion \$/a</b>	<b>120.7</b>
Conventional (fossil & nuclear)	billion \$	76.1	35.1	96.5	1.9	209.6	billion \$/a	5.4
Renewables	billion \$	209.1	1,075.2	1,417.6	1,794.7	4,496.6	billion \$/a	115.3
Biomass	billion \$	5.1	6.4	9.2	9.5	30.1	billion \$/a	0.8
Hydro	billion \$	21.8	22.4	17.7	20.8	82.7	billion \$/a	2.1
Wind	billion \$	32.3	140.1	225.0	217.7	615.1	billion \$/a	15.8
PV	billion \$	59.4	244.9	262.7	358.4	925.4	billion \$/a	23.7
Geothermal	billion \$	14.7	29.6	36.9	48.2	129.4	billion \$/a	3.3
Solar thermal power plants	billion \$	66.6	602.1	787.5	1,085.3	2,541.4	billion \$/a	65.2
Ocean energy	billion \$	9.2	29.7	78.6	54.9	172.5	billion \$/a	4.4

Table 13.6.23: Middle East: Investments in renewable heat generation

REF	UNIT	2012-2020	2021-2030	2031-2040	2041-2050	2012-2050	UNIT	ANNUAL AVERAGE 2012-2050
Heat pumps	billion \$	0.0	0.0	0.0	0.0	0.0	billion \$/a	0.0
Deep geothermal	billion \$	0.0	0.0	0.0	0.0	0.0	billion \$/a	0.0
Solar thermal	billion \$	0.7	1.0	1.7	2.4	5.8	billion \$/a	0.1
Biomass	billion \$	7.1	11.6	15.6	21.0	55.3	billion \$/a	1.4
<b>Total</b>	<b>billion \$</b>	<b>7.8</b>	<b>12.6</b>	<b>17.4</b>	<b>23.4</b>	<b>61.2</b>	<b>billion \$/a</b>	<b>1.6</b>
<b>E[R]</b>								
Heat pumps	billion \$	13.3	15.1	45.2	82.8	156.4	billion \$/a	4.0
Deep geothermal	billion \$	24.3	14.4	28.7	33.8	101.2	billion \$/a	2.6
Solar thermal	billion \$	16.3	37.5	49.7	67.3	170.9	billion \$/a	3.4
Biomass	billion \$	13.6	5.9	14.5	10.5	44.5	billion \$/a	1.1
<b>Total</b>	<b>billion \$</b>	<b>67.5</b>	<b>72.9</b>	<b>138.1</b>	<b>154.6</b>	<b>433.1</b>	<b>billion \$/a</b>	<b>11.1</b>
<b>ADV E[R]</b>								
Heat pumps	billion \$	13.3	15.1	45.2	82.8	156.4	billion \$/a	4.0
Deep geothermal	billion \$	24.3	14.4	28.7	33.8	101.2	billion \$/a	2.6
Solar thermal	billion \$	16.3	37.5	49.7	67.3	170.9	billion \$/a	4.4
Biomass	billion \$	13.6	5.9	14.5	10.5	44.5	billion \$/a	1.1
<b>Total</b>	<b>billion \$</b>	<b>67.5</b>	<b>72.9</b>	<b>138.1</b>	<b>154.6</b>	<b>433.0</b>	<b>billion \$/a</b>	<b>12.1</b>

Table 13.6.24: Middle East: Total employment in the energy sector THOUSAND JOBS

By sector	REFERENCE SCENARIO				ADV E[R] SCENARIO		
	2015	2020	2025	2030	2020	2025	2030
Construction and installation	36	41	38	32	211	371	336
Manufacturing	17	17	16	12	46	72	67
Operations and maintenance	63	76	85	87	110	181	284
Fuel supply (domestic)	338	384	422	436	360	335	293
Coal and gas export	57.5	58.7	64.9	66.3	61.2	45.9	30.6
Solar and geothermal heat	5	5	7	5	105	107	105
<b>Total jobs (thousands)</b>	<b>516</b>	<b>581</b>	<b>632</b>	<b>638</b>	<b>894</b>	<b>1,112</b>	<b>1,116</b>
<b>By technology</b>							
Coal	3	2	2	2	1	1	1
Gas, oil & diesel	473	523	563	564	451	394	317
Nuclear	8	11	10	9	0	0	0
<b>Renewable</b>	<b>31</b>	<b>45</b>	<b>56</b>	<b>63</b>	<b>442</b>	<b>716</b>	<b>797</b>
Biomass	5	9	14	19	36	51	54
Hydro	12	13	14	11	19	9	11
Wind	0.9	2.6	3.8	8.3	54	77	104
PV	5.7	10	11.6	13.8	159	316	287
Geothermal power	0.0	0.0	0.0	0.0	4.7	4.4	6
Solar thermal power	2.4	4.4	5.6	5.9	53	146	214
Ocean	-	-	-	-	12	6	17
Solar - heat	5	5	6.7	5.4	69	93	92
Geothermal & heat pump	0.0	-	-	-	36	14	13
<b>Total jobs (thousands)</b>	<b>516</b>	<b>581</b>	<b>632</b>	<b>638</b>	<b>894</b>	<b>1,112</b>	<b>1,116</b>

# EASTERN EUROPE/EURASIA: REFERENCE SCENARIO

**Table 13.7.1 Eastern Europe/Eurasia: Electricity generation TWh/a**

	2012	2020	2025	2030	2040	2050
<b>Power plants</b>	<b>810</b>	<b>974</b>	<b>1,152</b>	<b>1,329</b>	<b>1,693</b>	<b>2,067</b>
Hard coal (& non-renewable waste)	82	61	76	90	146	262
Lignite	69	76	81	87	100	113
Gas	62	136	223	307	497	614
<i>of which from H<sup>1</sup></i>	0	0	0	0	0	0
Oil	7	3	2	2	1	0
Diesel	3	3	3	3	3	2
Nuclear	297	333	369	405	417	430
Biomass (& renewable waste)	0	12	18	24	46	69
Hydro	283	326	346	367	413	458
Wind	5	16	23	29	48	67
<i>of which wind offshore</i>	0	0	1	2	6	10
PV	1	5	6	7	8	11
Geothermal	0	3	6	8	13	20
Solar thermal power plants	0	0	0	0	0	0
Ocean energy	0	0	0	0	0	0
<b>Combined heat and power plants</b>	<b>933</b>	<b>975</b>	<b>993</b>	<b>1,014</b>	<b>1,044</b>	<b>1,075</b>
Hard coal (& non-renewable waste)	175	187	193	199	201	202
Lignite	91	91	90	89	87	85
Gas	635	677	698	720	751	785
<i>of which from H<sup>1</sup></i>	0	0	0	0	0	0
Oil	30	19	11	3	1	0
Biomass (& renewable waste)	1	2	2	2	3	4
Geothermal	0	0	0	0	0	0
Hydrogen	0	0	0	0	0	0
<b>CHP by producer</b>						
Main activity producers	864	899	912	926	945	963
Autoproducers	69	76	81	88	99	112
<b>Total generation</b>	<b>1,743</b>	<b>1,949</b>	<b>2,146</b>	<b>2,343</b>	<b>2,737</b>	<b>3,142</b>
Fossil	1,155	1,252	1,376	1,500	1,787	2,083
Hard coal (& non-renewable waste)	257	248	269	289	347	484
Lignite	160	166	171	176	187	198
Gas	697	813	920	1,027	1,249	1,399
Oil	37	22	13	5	2	0
Diesel	3	3	3	3	3	2
Nuclear	297	333	369	405	417	430
Hydrogen	0	0	0	0	0	0
<i>of which renewable H<sup>1</sup></i>	0	0	0	0	0	0
<b>Renewables (w/o renewable hydrogen)</b>	<b>291</b>	<b>363</b>	<b>400</b>	<b>437</b>	<b>532</b>	<b>629</b>
Hydro	283	326	346	367	413	458
Wind	5	16	23	29	48	67
PV	1	5	6	7	8	11
Biomass (& renewable waste)	1	13	20	26	49	73
Geothermal	0	3	6	8	13	20
Solar thermal power plants	0	0	0	0	0	0
Ocean energy	0	0	0	0	0	0
Distribution losses	184	211	234	258	303	353
Own consumption electricity	294	296	308	320	366	376
Electricity for hydrogen production	0	0	0	0	0	0
Electricity for synfuel production	0	0	0	0	0	0
<b>Final energy consumption (electricity)</b>	<b>1,254</b>	<b>1,434</b>	<b>1,595</b>	<b>1,757</b>	<b>2,060</b>	<b>2,405</b>
Fluctuating RES (PV, Wind, Ocean)	7	21	29	36	57	78
Share of fluctuating RES	0%	1%	1%	2%	2%	2%
<b>RES share (domestic generation)</b>	<b>17%</b>	<b>19%</b>	<b>19%</b>	<b>19%</b>	<b>19%</b>	<b>20%</b>

**Table 13.7.2 Eastern Europe/Eurasia: Final energy consumption in transport PJ/a**

	2012	2020	2025	2030	2040	2050
<b>Road</b>	<b>3,712</b>	<b>4,053</b>	<b>4,450</b>	<b>4,846</b>	<b>5,404</b>	<b>5,515</b>
Fossil fuels	3,666	3,971	4,297	4,623	5,024	4,956
Biofuels	18	23	22	21	21	20
Synfuels	0	0	0	0	0	0
Natural gas	27	50	89	129	214	303
Hydrogen	0	0	0	0	0	0
Electricity	1	9	42	72	145	236
<b>Rail</b>	<b>591</b>	<b>635</b>	<b>658</b>	<b>682</b>	<b>732</b>	<b>777</b>
Fossil fuels	189	208	215	222	234	244
Biofuels	0	0	0	0	0	0
Synfuels	0	0	0	0	0	0
Electricity	401	427	442	460	497	533
<b>Navigation</b>	<b>45</b>	<b>66</b>	<b>68</b>	<b>71</b>	<b>72</b>	<b>75</b>
Fossil fuels	45	66	68	71	72	75
Biofuels	0	0	0	0	0	0
Synfuels	0	0	0	0	0	0
<b>Aviation</b>	<b>297</b>	<b>337</b>	<b>360</b>	<b>382</b>	<b>429</b>	<b>474</b>
Fossil fuels	297	337	360	382	429	474
Biofuels	0	0	0	0	0	0
Synfuels	0	0	0	0	0	0
<b>Total (incl. pipelines)</b>	<b>6,012</b>	<b>6,471</b>	<b>6,929</b>	<b>7,388</b>	<b>8,072</b>	<b>8,305</b>
Fossil fuels	4,198	4,582	4,940	5,299	5,759	5,749
Biofuels (incl. biogas)	18	23	22	21	21	20
Synfuels	0	0	0	0	0	0
Natural gas	1,393	1,429	1,483	1,536	1,649	1,768
Hydrogen	0	0	0	0	0	0
Electricity	402	436	484	532	642	769
<b>Total RES</b>	<b>86</b>	<b>104</b>	<b>112</b>	<b>121</b>	<b>146</b>	<b>174</b>
<b>RES share</b>	<b>1%</b>	<b>2%</b>	<b>2%</b>	<b>2%</b>	<b>2%</b>	<b>2%</b>

**Table 13.7.3 Eastern Europe/Eurasia: Heat supply PJ/a**

	2012	2020	2025	2030	2040	2050
<b>District heating plants</b>	<b>4,069</b>	<b>3,832</b>	<b>4,132</b>	<b>4,431</b>	<b>4,866</b>	<b>5,295</b>
Fossil fuels	4,002	3,746	4,027	4,305	4,699	5,082
Biomass	66	85	104	125	167	213
Solar collectors	0	0	0	0	0	0
Geothermal	0	0	0	0	0	0
<b>Heat from CHP<sup>1</sup></b>	<b>4,031</b>	<b>4,045</b>	<b>4,027</b>	<b>4,033</b>	<b>4,004</b>	<b>4,016</b>
Fossil fuels	4,015	4,025	4,005	4,010	3,977	3,985
Biomass	16	20	22	24	27	31
Geothermal	0	0	0	0	0	0
Hydrogen	0	0	0	0	0	0
<b>Direct heating</b>	<b>9,640</b>	<b>11,543</b>	<b>12,475</b>	<b>13,431</b>	<b>15,213</b>	<b>17,196</b>
Fossil fuels	8,397	9,997	10,851	11,727	13,336	15,115
Biomass	427	710	777	846	996	1,176
Solar collectors	4	6	7	8	10	14
Geothermal	0	0	0	0	0	0
Heat pumps <sup>2</sup>	5	7	8	9	12	15
Electric direct heating	807	824	832	841	859	876
Hydrogen	0	0	0	0	0	0
<b>Total heat supply<sup>3</sup></b>	<b>17,440</b>	<b>19,420</b>	<b>20,633</b>	<b>21,895</b>	<b>24,084</b>	<b>26,507</b>
Fossil fuels	16,414	17,768	18,883	20,042	22,014	24,181
Biomass	509	816	904	995	1,190	1,421
Solar collectors	4	6	7	8	10	14
Geothermal	0	0	0	0	0	0
Heat pumps <sup>2</sup>	5	7	8	9	12	15
Electric direct heating	807	824	832	841	859	876
Hydrogen	0	0	0	0	0	0
<b>RES share (including RES electricity)</b>	<b>4%</b>	<b>5%</b>	<b>5%</b>	<b>5%</b>	<b>6%</b>	<b>6%</b>

<sup>1</sup> public CHP and CHP autoproduction / <sup>2</sup> heat from ambient energy and electricity use / <sup>3</sup> incl. process heat, cooking

**Table 13.7.4: Eastern Europe/Eurasia: Installed capacity GW**

	2012	2020	2025	2030	2040	2050
<b>Total generation</b>	<b>432</b>	<b>476</b>	<b>508</b>	<b>539</b>	<b>612</b>	<b>681</b>
<b>Fossil</b>	<b>290</b>	<b>310</b>	<b>327</b>	<b>344</b>	<b>391</b>	<b>431</b>
Hard coal (& non-renewable waste)	68	65	66	67	71	84
Lignite	42	43	42	41	38	35
Gas (w/o H <sup>1</sup> )	157	185	207	229	277	297
Oil	15	9	4	2	2	2
Diesel	2	2	2	2	3	2
Nuclear	43	47	52	56	57	59
Hydrogen (fuel cells, gas power plants, gas CHP)	0	0	0	0	0	0
<b>Renewables</b>	<b>99</b>	<b>119</b>	<b>129</b>	<b>139</b>	<b>164</b>	<b>191</b>
Hydro	93	103	108	114	125	139
Wind	4	8	11	13	20	27
<i>of which wind offshore</i>	0	0	0	0	1	2
PV	1	4	5	6	7	9
Biomass (& renewable waste)	1	3	4	5	9	13
Geothermal	0	0	1	1	2	3
Solar thermal power plants	0	0	0	0	0	0
Ocean energy	0	0	0	0	0	0
Fluctuating RES (PV, Wind, Ocean)	5	13	16	19	28	36
Share of fluctuating RES	1%	3%	3%	4%	5%	5%
<b>RES share (domestic generation)</b>	<b>23%</b>	<b>25%</b>	<b>25%</b>	<b>26%</b>	<b>27%</b>	<b>28%</b>

**Table 13.7.5: Eastern Europe/Eurasia: Final energy demand PJ/a**

	2012	2020	2025	2030	2040	2050
<b>Total (incl. non-energy use)</b>	<b>31,063</b>	<b>34,176</b>	<b>36,582</b>	<b>38,938</b>	<b>42,623</b>	<b>46,114</b>
<b>Total energy use</b>	<b>27,438</b>	<b>30,457</b>	<b>32,602</b>	<b>34,747</b>	<b>38,328</b>	<b>41,764</b>
<b>Transport</b>	<b>6,012</b>	<b>6,471</b>	<b>6,929</b>	<b>7,388</b>	<b>8,072</b>	<b>8,305</b>
Oil products	4,198	4,582	4,940	5,299	5,759	5,749
Natural gas	1,393	1,429	1,483	1,536	1,649	1,768
Biofuels	18	23	22	21	21	20
Synfuels	0	0	0	0	0	0
Electricity	402	436	484	532	642	769
RES electricity	67	81	90	99	125	154
Hydrogen	0	0	0	0	0	0
<b>RES share Transport</b>	<b>1%</b>	<b>2%</b>	<b>2%</b>	<b>2%</b>	<b>2%</b>	<b>2%</b>
<b>Industry</b>	<b>9,526</b>	<b>10,982</b>	<b>11,858</b>	<b>12,734</b>	<b>14,078</b>	<b>15,557</b>
Electricity	2,009	2,320	2,568	2,816	3,252	3,742
RES electricity	336	433	479	526	632	749
Public district heat	2,403	2,413	2,529	2,645	2,765	2,886
RES district heat	12	30	36	43	56	71
Hard coal & lignite	1,448	2,003	2,121	2,258	2,437	2,571
Oil products	789	866	879	892	870	849
Gas	2,826	3,270	3,604	3,938	4,490	5,151
Solar	0	0	0	0	1	1
Biomass	51	111	148	184	261	358
Geothermal	0	0	0	0	0	0
Hydrogen	0	0	0	0	0	0
<b>RES share Industry</b>	<b>4%</b>	<b>5%</b>	<b>6%</b>	<b>6%</b>	<b>7%</b>	<b>8%</b>
<b>Other Sectors</b>	<b>11,901</b>	<b>13,004</b>	<b>13,814</b>	<b>14,624</b>	<b>16,178</b>	<b>17,902</b>
Electricity	2,104	2,408	2,691	2,976	3,523	4,147

**Table 13.7.8 Eastern Europe/Eurasia: Electricity generation TWh/a**

	2012	2020	2025	2030	2040	2050
<b>Power plants</b>	<b>810</b>	<b>927</b>	<b>1,132</b>	<b>1,387</b>	<b>1,962</b>	<b>2,336</b>
Hard coal (& non-renewable waste)	82	43	37	38	15	0
Lignite	69	43	33	15	0	0
Gas	62	170	189	209	226	81
of which from H <sub>2</sub>	0	0	0	0	0	0
Oil	7	3	3	3	2	1
Diesel	3	3	3	3	2	1
Nuclear	297	269	230	150	0	0
Biomass (& renewable waste)	0	23	39	41	40	21
Hydro	283	326	346	360	375	380
Wind	5	36	193	415	892	1,256
of which wind offshore	0	1	17	48	161	240
Geothermal	0	4	10	24	76	104
Solar thermal power plants	0	0	1	5	26	40
Ocean energy	0	0	1	5	24	44
<b>Combined heat and power plants</b>	<b>933</b>	<b>976</b>	<b>989</b>	<b>1,001</b>	<b>1,012</b>	<b>966</b>
Hard coal (& non-renewable waste)	175	164	136	85	0	0
Lignite	91	80	51	18	0	0
Gas	635	669	691	711	609	389
of which from H <sub>2</sub>	0	0	0	0	26	79
Oil	30	14	5	0	0	0
Biomass (& renewable waste)	1	49	97	151	288	384
Geothermal	0	0	10	36	114	186
Hydrogen	0	0	0	0	0	6
<b>CHP by producer</b>						
Main activity producers	864	899	903	903	888	829
Autoproducers	69	77	86	98	124	137
<b>Total generation</b>	<b>1,743</b>	<b>1,903</b>	<b>2,121</b>	<b>2,388</b>	<b>2,973</b>	<b>3,302</b>
Fossil	1,155	1,188	1,145	1,078	826	392
Hard coal (& non-renewable waste)	257	207	173	122	15	0
Lignite	160	123	84	33	0	0
Gas	697	838	880	920	809	391
Oil	37	17	5	0	0	0
Diesel	3	3	3	3	2	1
Nuclear	297	269	230	150	0	0
Hydrogen	0	0	0	0	27	85
of which renewable H <sub>2</sub>	0	0	0	0	19	75
<b>Renewables (w/o renewable hydrogen)</b>	<b>291</b>	<b>447</b>	<b>746</b>	<b>1,160</b>	<b>2,120</b>	<b>2,825</b>
Hydro	283	326	346	360	375	380
Wind	5	36	193	415	892	1,256
PV	1	8	48	123	285	410
Biomass (& renewable waste)	1	72	136	191	328	405
Geothermal	0	4	20	60	190	290
Solar thermal power plants	0	0	1	5	26	40
Ocean energy	0	0	1	5	24	44
Distribution losses	184	206	234	268	328	347
Own consumption electricity	294	294	293	288	224	124
Electricity for hydrogen production	0	0	1	7	190	468
Electricity for synfuel production	0	0	0	0	0	0
<b>Final energy consumption (electricity)</b>	<b>1,254</b>	<b>1,404</b>	<b>1,593</b>	<b>1,825</b>	<b>2,232</b>	<b>2,363</b>
Fluctuating RES (PV, Wind, Ocean)	7	44	242	543	1,201	1,710
Share of fluctuating RES	0%	2%	11%	23%	40%	52%
<b>RES share (domestic generation)</b>	<b>17%</b>	<b>23%</b>	<b>35%</b>	<b>49%</b>	<b>72%</b>	<b>88%</b>

**Table 13.7.9 Eastern Europe/Eurasia: Final energy consumption in transport PJ/a**

	2012	2020	2025	2030	2040	2050
<b>Road</b>	<b>3,712</b>	<b>4,013</b>	<b>4,146</b>	<b>4,151</b>	<b>3,729</b>	<b>2,648</b>
Fossil fuels	3,666	3,848	3,683	3,285	1,972	451
Biofuels	18	99	277	491	526	475
Synfuels	0	0	0	0	0	0
Natural gas	27	53	100	107	129	111
Hydrogen	0	0	2	19	209	445
Electricity	1	13	85	249	894	1,166
<b>Rail</b>	<b>591</b>	<b>639</b>	<b>655</b>	<b>685</b>	<b>740</b>	<b>780</b>
Fossil fuels	189	193	171	129	86	52
Biofuels	0	10	9	31	34	28
Synfuels	0	0	0	0	0	0
Electricity	401	436	475	525	620	700
<b>Navigation</b>	<b>45</b>	<b>66</b>	<b>66</b>	<b>65</b>	<b>61</b>	<b>57</b>
Fossil fuels	45	63	63	59	49	37
Biofuels	0	3	3	6	12	20
Synfuels	0	0	0	0	0	0
<b>Aviation</b>	<b>297</b>	<b>337</b>	<b>343</b>	<b>347</b>	<b>357</b>	<b>365</b>
Fossil fuels	297	337	333	327	286	237
Biofuels	0	0	10	21	71	128
Synfuels	0	0	0	0	0	0
<b>Total (incl. pipelines)</b>	<b>6,012</b>	<b>6,289</b>	<b>6,306</b>	<b>6,206</b>	<b>5,570</b>	<b>4,250</b>
Fossil fuels	4,198	4,441	4,249	3,800	2,393	777
Biofuels (incl. biogas)	18	112	299	548	643	650
Synfuels	0	0	0	0	0	0
Natural gas	1,393	1,281	1,177	1,027	681	211
Hydrogen	0	0	2	19	209	445
Electricity	402	455	578	812	1,644	2,166
<b>Total RES</b>	<b>86</b>	<b>219</b>	<b>503</b>	<b>952</b>	<b>1,976</b>	<b>2,943</b>
<b>RES share</b>	<b>1%</b>	<b>3%</b>	<b>8%</b>	<b>15%</b>	<b>35%</b>	<b>69%</b>

**Table 13.7.10 Eastern Europe/Eurasia: Heat supply PJ/a**

	2012	2020	2025	2030	2040	2050
<b>District heating plants</b>	<b>4,069</b>	<b>3,756</b>	<b>4,065</b>	<b>4,044</b>	<b>3,535</b>	<b>2,558</b>
Fossil fuels	4,002	3,473	3,314	2,847	1,326	256
Biomass	66	275	568	793	1,220	1,113
Solar collectors	0	4	102	243	495	550
Geothermal	0	4	81	162	495	639
<b>Heat from CHP<sup>1</sup></b>	<b>4,031</b>	<b>4,050</b>	<b>3,978</b>	<b>3,970</b>	<b>4,109</b>	<b>4,275</b>
Fossil fuels	4,015	3,852	3,513	3,089	1,994	1,008
Biomass	16	197	393	615	1,194	1,617
Geothermal	0	0	73	266	832	1,358
Hydrogen	0	0	0	0	89	292
<b>Direct heating</b>	<b>9,640</b>	<b>11,065</b>	<b>10,690</b>	<b>10,312</b>	<b>9,371</b>	<b>7,933</b>
Fossil fuels	8,397	9,126	7,874	6,335	2,865	589
Biomass	427	961	1,227	1,442	1,633	1,635
Solar collectors	4	54	259	597	1,520	1,721
Geothermal	0	0	8	39	142	167
Heat pumps <sup>2</sup>	5	46	181	455	1,272	1,630
Electric direct heating	807	877	1,141	1,443	1,882	2,042
Hydrogen	0	0	0	0	57	150
<b>Total heat supply<sup>3</sup></b>	<b>17,740</b>	<b>18,871</b>	<b>18,734</b>	<b>18,326</b>	<b>17,016</b>	<b>14,766</b>
Fossil fuels	16,414	16,452	14,701	12,272	6,185	1,852
Biomass	509	1,434	2,188	2,850	4,047	4,365
Solar collectors	4	58	361	840	2,015	2,271
Geothermal	0	4	162	467	1,469	2,165
Heat pumps <sup>2</sup>	5	46	181	455	1,272	1,630
Electric direct heating	807	877	1,141	1,443	1,882	2,042
Hydrogen	0	0	0	0	146	442
<b>RES share (including RES electricity)</b>	<b>4%</b>	<b>9%</b>	<b>18%</b>	<b>29%</b>	<b>61%</b>	<b>86%</b>

<sup>1</sup> public CHP and CHP autoproduction / <sup>2</sup> heat from ambient energy and electricity use / <sup>3</sup> incl. process heat, cooking

**Table 13.7.10: Eastern Europe/Eurasia: Installed capacity GW**

	2012	2020	2025	2030	2040	2050
<b>Total generation</b>	<b>432</b>	<b>473</b>	<b>571</b>	<b>723</b>	<b>1,071</b>	<b>1,334</b>
<b>Fossil</b>	<b>290</b>	<b>290</b>	<b>267</b>	<b>245</b>	<b>224</b>	<b>179</b>
Hard coal (& non-renewable waste)	68	54	43	29	8	0
Lignite	42	32	21	9	0	0
Gas (w/o H <sub>2</sub> )	157	191	198	205	214	178
Oil	21	12	4	0	0	0
Diesel	2	2	2	2	2	0
Nuclear	43	38	32	21	0	0
Hydrogen (fuel cells, gas power plants, gas CHP)	0	0	0	0	7	35
<b>Renewables</b>	<b>99</b>	<b>145</b>	<b>272</b>	<b>457</b>	<b>839</b>	<b>1,119</b>
Hydro	93	103	108	111	114	115
Wind	4	18	91	187	370	506
of which wind offshore	0	0	5	15	50	72
Biomass (& renewable waste)	1	7	42	107	246	342
Geothermal	0	1	3	8	26	40
Solar thermal power plants	0	0	1	5	5	8
Ocean energy	0	0	1	2	11	18
Fluctuating RES (PV, Wind, Ocean)	5	25	133	297	627	866
Share of fluctuating RES	1%	5%	23%	41%	59%	65%
<b>RES share (domestic generation)</b>	<b>23%</b>	<b>31%</b>	<b>48%</b>	<b>63%</b>	<b>78%</b>	<b>84%</b>

**Table 13.7.12: Eastern Europe/Eurasia: Final energy demand PJ/a**

	2012	2020	2025	2030	2040	2050
<b>Total (incl. non-energy use)</b>	<b>31,063</b>	<b>33,152</b>	<b>33,033</b>	<b>32,491</b>	<b>29,761</b>	<b>25,594</b>
<b>Total energy use</b>	<b>27,438</b>	<b>29,470</b>	<b>29,252</b>	<b>28,635</b>	<b>26,110</b>	<b>22,114</b>
<b>Transport</b>	<b>6,012</b>	<b>6,289</b>	<b>6,306</b>	<b>6,206</b>	<b>5,570</b>	<b>4,250</b>
Oil products	4,198	4,441	4,249	3,800	2,393	777
Natural gas	1,393	1,281	1,177	1,027	681	211
Biofuels	18	112	299	548	643	650
Synfuels	0	0	0	0	0	0
Electricity	402	455	578	812	1,644	2,166
RES electricity	67	107	203	395	1,183	1,902
Hydrogen	0	0	2	19	209	445
<b>RES share Transport</b>	<b>1%</b>	<b>3%</b>	<b>9%</b>	<b>15%</b>	<b>35%</b>	<b>69%</b>
<b>Industry</b>	<b>9,526</b>	<b>10,598</b>	<b>10,599</b>	<b>10,550</b>	<b>9,467</b>	<b>7,614</b>
Electricity	2,009	2,240	2,510	2,818	3,175	3,074
RES electricity	336	525	882	1,389	2,284	2,699
Public district heat	2,403	2,412	2,535	2,557	2,322	2,078
RES district heat	23	154	397	679	1,346	1,737
Hard coal & lignite	1,448	1,631	1,133	633	0	0
Oil products	789	697	504	307	98	6
Gas	2,826	3,187	3,153	3,087	2,028	394
Solar	0	16	118	236	496	528
Biomass	51	410	611	806	962	1,000
Geothermal	0	5	36	107	324	375
Hydrogen	0	0	0	0	62	158
<b>RES share Industry</b>	<b>4%</b>	<b>10%</b>	<b>19%</b>	<b>30%</b>	<b>58%</b>	<b>85%</b>
<b>Other Sectors</b>	<b>11,901</b>					

# EASTERN EUROPE/EURASIA: ADVANCED ENERGY [R]EVOLUTION SCENARIO

Table 13.17.15 Eastern Europe/Eurasia: Electricity generation TWh/a

	2012	2020	2025	2030	2040	2050
<b>Power plants</b>	<b>810</b>	<b>928</b>	<b>1,198</b>	<b>1,619</b>	<b>2,736</b>	<b>4,025</b>
Hard coal (& non-renewable waste)	82	43	33	11	0	0
Lignite	69	43	33	15	0	0
Gas	62	170	189	209	232	154
<i>of which from H<sub>2</sub></i>	0	0	1	4	32	154
Oil	7	0	0	0	0	0
Diesel	3	3	3	3	2	0
Nuclear	297	269	230	150	0	0
Biomass (& renewable waste)	0	23	39	41	40	19
Hydro	283	326	346	360	375	380
Wind	5	37	229	579	1,341	2,205
<i>of which wind offshore</i>	0	1	32	127	353	570
PV	1	8	66	181	462	780
Geothermal	0	4	27	54	203	367
Solar thermal power plants	0	0	1	9	46	60
Ocean energy	0	0	1	7	34	60
<b>Combined heat and power plants</b>	<b>933</b>	<b>976</b>	<b>989</b>	<b>1,001</b>	<b>1,012</b>	<b>956</b>
Hard coal (& non-renewable waste)	175	164	136	85	0	0
Lignite	91	80	51	18	0	0
Gas	635	689	691	711	603	316
<i>of which from H<sub>2</sub></i>	0	0	3	14	84	316
Oil	30	14	5	0	0	0
Biomass (& renewable waste)	1	49	97	151	288	393
Geothermal	0	0	10	36	114	222
Hydrogen	0	0	0	0	7	25
<b>CHP by producer</b>						
Main activity producers	864	899	903	903	888	829
Autoproducers	69	77	86	98	124	127
<b>Total generation</b>	<b>1,743</b>	<b>1,904</b>	<b>2,187</b>	<b>2,620</b>	<b>3,747</b>	<b>4,980</b>
Fossil	1,155	1,188	1,137	1,033	721	0
Hard coal (& non-renewable waste)	257	207	169	95	0	0
Lignite	160	123	84	33	0	0
Gas	697	838	876	902	718	0
Oil	37	17	5	0	0	0
Diesel	3	3	3	3	2	0
Nuclear	297	269	230	150	0	0
Hydrogen	0	0	4	19	124	495
<i>of which renewable H<sub>2</sub></i>	0	0	2	10	99	495
<b>Renewables (w/o renewable hydrogen)</b>	<b>291</b>	<b>447</b>	<b>816</b>	<b>1,418</b>	<b>2,903</b>	<b>4,485</b>
Hydro	283	326	346	360	375	380
Wind	5	37	229	579	1,341	2,205
PV	1	8	66	181	462	780
Biomass (& renewable waste)	1	72	136	191	328	412
Geothermal	0	4	37	91	317	589
Solar thermal power plants	0	0	1	9	46	60
Ocean energy	0	0	1	7	34	60
Distribution losses	184	206	234	268	328	347
Own consumption electricity	294	294	293	288	224	124
Electricity for hydrogen production	0	0	47	153	712	1,820
Electricity for syngas production	0	0	0	0	25	144
<b>Final energy consumption (electricity)</b>	<b>1,254</b>	<b>1,404</b>	<b>1,614</b>	<b>1,910</b>	<b>2,459</b>	<b>2,545</b>
Fluctuating RES (PV, Wind, Ocean)	7	45	296	767	1,837	3,045
Share of fluctuating RES	0%	2%	14%	29%	49%	61%
<b>RES share (domestic generation)</b>	<b>17%</b>	<b>23%</b>	<b>37%</b>	<b>55%</b>	<b>80%</b>	<b>100%</b>

Table 13.17.16 Eastern Europe/Eurasia: Final Energy Consumption Transport PJ/a

	2012	2020	2025	2030	2040	2050
<b>Road</b>	<b>3,712</b>	<b>4,013</b>	<b>4,046</b>	<b>3,859</b>	<b>3,012</b>	<b>1,870</b>
Fossil fuels	3,666	3,848	3,555	3,085	1,215	0
Biofuels	18	99	268	305	493	359
Synfuels	0	0	0	0	28	120
Natural gas	27	53	92	76	32	0
Hydrogen	0	0	33	87	354	461
Electricity	1	14	99	307	919	1,050
<b>Rail</b>	<b>591</b>	<b>639</b>	<b>679</b>	<b>749</b>	<b>910</b>	<b>985</b>
Fossil fuels	189	191	154	102	43	0
Biofuels	0	10	8	18	27	30
Synfuels	0	0	0	0	2	10
Electricity	401	438	517	629	838	945
<b>Navigation</b>	<b>45</b>	<b>66</b>	<b>66</b>	<b>65</b>	<b>61</b>	<b>57</b>
Fossil fuels	45	63	63	56	40	0
Biofuels	0	3	3	9	20	43
Synfuels	0	0	0	0	1	14
<b>Aviation</b>	<b>297</b>	<b>337</b>	<b>336</b>	<b>330</b>	<b>311</b>	<b>292</b>
Fossil fuels	297	337	326	287	202	0
Biofuels	0	0	9	43	103	219
Synfuels	0	0	0	0	6	73
<b>Total (incl. pipelines)</b>	<b>6,012</b>	<b>6,246</b>	<b>6,137</b>	<b>5,833</b>	<b>4,789</b>	<b>3,424</b>
Fossil fuels	4,198	4,439	4,098	3,530	1,500	0
Biofuels (incl. biogas)	18	112	288	375	643	650
Synfuels	0	0	0	0	37	217
Natural gas	1,393	1,238	1,065	829	240	0
Hydrogen	0	0	33	87	354	461
Electricity	402	458	653	1,013	2,016	2,095
<b>Total RES</b>	<b>86</b>	<b>220</b>	<b>545</b>	<b>974</b>	<b>2,571</b>	<b>3,424</b>
<b>RES share</b>	<b>1%</b>	<b>4%</b>	<b>9%</b>	<b>17%</b>	<b>54%</b>	<b>100%</b>

Table 13.17.17 Eastern Europe/Eurasia: Heat Supply PJ/a

	2012	2020	2025	2030	2040	2050
<b>District heating plants</b>	<b>4,069</b>	<b>3,756</b>	<b>4,065</b>	<b>4,044</b>	<b>3,527</b>	<b>2,259</b>
Fossil fuels	4,002	3,473	3,314	2,847	1,323	0
Biomass	66	275	568	793	1,217	1,073
Solar collectors	0	4	102	243	494	531
Geothermal	0	4	81	162	494	655
<b>Heat from CHP<sup>1</sup></b>	<b>4,031</b>	<b>4,050</b>	<b>3,978</b>	<b>3,971</b>	<b>4,129</b>	<b>4,466</b>
Fossil fuels	4,015	3,852	3,500	3,036	1,764	0
Biomass	16	197	393	615	1,194	1,657
Geothermal	0	0	73	266	836	1,623
Hydrogen	0	0	13	54	335	1,187
<b>Direct heating</b>	<b>9,640</b>	<b>11,065</b>	<b>10,690</b>	<b>10,311</b>	<b>9,358</b>	<b>8,024</b>
Fossil fuels	8,397	9,126	7,844	6,227	2,291	0
Biomass	427	961	1,227	1,441	1,631	1,630
Solar collectors	4	54	259	597	1,518	1,742
Geothermal	0	0	8	39	141	166
Heat pumps <sup>2</sup>	5	46	181	455	1,392	1,888
Electric direct heating	807	877	1,141	1,443	2,028	2,293
Hydrogen	0	0	31	108	357	305
<b>Total heat supply<sup>3</sup></b>	<b>17,470</b>	<b>18,871</b>	<b>18,734</b>	<b>18,326</b>	<b>17,015</b>	<b>14,749</b>
Fossil fuels	16,414	16,452	14,658	12,110	5,378	0
Biomass	509	1,434	2,188	2,849	4,042	4,360
Solar collectors	4	58	361	839	2,012	2,273
Geothermal	0	4	162	467	1,471	2,444
Heat pumps <sup>2</sup>	5	46	181	455	1,392	1,888
Electric direct heating	807	877	1,141	1,443	2,028	2,293
Hydrogen	0	0	44	162	692	1,492
<b>RES share (including RES electricity)</b>	<b>4%</b>	<b>9%</b>	<b>18%</b>	<b>30%</b>	<b>66%</b>	<b>100%</b>

<sup>1</sup> public CHP and CHP autoproduction / <sup>2</sup> heat from ambient energy and electricity use / <sup>3</sup> incl. process heat, cooking

Table 13.17.18: Eastern Europe/Eurasia: Installed capacity GW

	2012	2020	2025	2030	2040	2050
<b>Total generation</b>	<b>432</b>	<b>473</b>	<b>602</b>	<b>838</b>	<b>1,468</b>	<b>2,054</b>
<b>Fossil</b>	<b>290</b>	<b>290</b>	<b>265</b>	<b>234</b>	<b>237</b>	<b>0</b>
Hard coal (& non-renewable waste)	68	54	42	22	0	0
Lignite	42	32	21	9	0	0
Gas (w/o H <sub>2</sub> )	157	191	197	201	235	0
Oil	21	12	4	0	0	0
Diesel	2	2	2	2	2	0
Nuclear	43	38	32	21	0	0
Hydrogen (fuel cells, gas power plants, gas CHP)	0	0	1	4	40	261
<b>Renewables</b>	<b>99</b>	<b>145</b>	<b>304</b>	<b>578</b>	<b>1,190</b>	<b>1,793</b>
Hydro	93	103	108	111	114	115
Wind	4	19	106	252	542	869
<i>of which wind offshore</i>	0	0	10	40	109	170
PV	1	7	57	157	399	600
Biomass (& renewable waste)	1	16	27	39	67	91
Geothermal	0	1	5	13	44	81
Solar thermal power plants	0	0	0	2	10	12
Ocean energy	0	0	1	3	16	25
Fluctuating RES (PV, Wind, Ocean)	5	26	163	413	956	1,494
Share of fluctuating RES	1%	5%	27%	49%	65%	73%
<b>RES share (domestic generation)</b>	<b>23%</b>	<b>31%</b>	<b>50%</b>	<b>69%</b>	<b>81%</b>	<b>87%</b>

Table 13.17.19: Eastern Europe/Eurasia: Final energy demand PJ/a

	2012	2020	2025	2030	2040	2050
<b>Total (incl. non-energy use)</b>	<b>31,063</b>	<b>33,109</b>	<b>32,864</b>	<b>32,195</b>	<b>29,131</b>	<b>24,993</b>
<b>Total energy use</b>	<b>27,438</b>	<b>29,427</b>	<b>29,083</b>	<b>28,339</b>	<b>25,480</b>	<b>21,513</b>
<b>Transport</b>	<b>6,012</b>	<b>6,246</b>	<b>6,137</b>	<b>5,833</b>	<b>4,789</b>	<b>3,424</b>
Oil products	4,198	4,439	4,098	3,530	1,500	0
Natural gas	1,393	1,238	1,065	829	240	0
Biofuels	18	112	288	375	643	650
Synfuels	0	0	0	0	37	217
Electricity	402	458	653	1,013	2,016	2,095
RES electricity	67	107	244	552	1,615	2,095
Hydrogen	0	0	33	87	354	461
<b>RES share Transport</b>	<b>1%</b>	<b>4%</b>	<b>9%</b>	<b>17%</b>	<b>54%</b>	<b>100%</b>
<b>Industry</b>	<b>9,526</b>	<b>10,598</b>	<b>10,599</b>	<b>10,569</b>	<b>9,492</b>	<b>7,673</b>
Electricity	2,009	2,240	2,510	2,845	3,359	3,332
RES electricity	336	526	938	1,551	2,891	3,332
Public district heat	2,403	2,412	2,535	2,557	2,318	2,073
RES district heat	23	154	399	687	1,386	2,073
Hard coal & lignite	1,448	1,631	1,133	633	0	0
Oil products	789	697	504	302	90	0
Gas	2,826	3,187	3,137	3,022	1,653	0
Solar	0	118	236	495	555	555
Biomass	51	410	611	806	960	998
Geothermal	0	5	36	107	349	395
Hydrogen	0	0	16	61	268	

Table 13.7.22: Eastern Europe/Eurasia: Investments in electricity generation

REF	UNIT	2012-2020	2021-2030	2031-2040	2041-2050	2012-2050	UNIT	ANNUAL AVERAGE 2012-2050
Fossil (w/o CHP)	billion \$	36.6	57.4	75.5	135.5	305.1	billion \$/a	7.8
Nuclear	billion \$	52.2	70.4	39.3	55.8	217.8	billion \$/a	5.6
CHP (fossil + renewable)	billion \$	166.0	101.1	43.7	7.5	318.3	billion \$/a	8.2
Renewables (w/o CHP)	billion \$	86.5	96.9	126.3	130.6	440.3	billion \$/a	11.3
<b>Total</b>	<b>billion \$</b>	<b>341.3</b>	<b>325.8</b>	<b>284.8</b>	<b>329.5</b>	<b>1,281.5</b>	<b>billion \$/a</b>	<b>32.9</b>
Conventional (fossil & nuclear)	billion \$	254.4	228.1	157.5	198.1	838.1	billion \$/a	21.5
Renewables	billion \$	86.9	97.8	127.3	131.4	443.4	billion \$/a	11.4
Biomass	billion \$	5.9	5.3	14.0	13.5	38.7	billion \$/a	1.0
Hydro	billion \$	60.4	75.1	80.0	87.8	303.2	billion \$/a	7.8
Wind	billion \$	9.4	9.8	22.5	20.2	61.9	billion \$/a	1.6
PV	billion \$	6.8	2.2	5.9	2.5	17.4	billion \$/a	0.4
Geothermal	billion \$	4.4	5.4	4.9	7.4	22.2	billion \$/a	0.6
Solar thermal power plants	billion \$	0.0	0.0	0.0	0.0	0.0	billion \$/a	0.0
Ocean energy	billion \$	0.0	0.0	0.0	0.0	0.0	billion \$/a	0.0
<b>E[R]</b>								
Fossil (w/o CHP)	billion \$	29.6	15.1	29.5	25.0	99.3	billion \$/a	2.5
Nuclear	billion \$	23.3	0.0	0.0	0.0	23.3	billion \$/a	0.6
CHP (fossil + renewable)	billion \$	175.8	172.9	231.9	246.0	826.7	billion \$/a	21.2
Renewables (w/o CHP)	billion \$	114.0	529.1	653.4	749.3	2,045.8	billion \$/a	52.5
<b>Total</b>	<b>billion \$</b>	<b>342.7</b>	<b>717.2</b>	<b>914.8</b>	<b>1,020.3</b>	<b>2,995.0</b>	<b>billion \$/a</b>	<b>76.8</b>
Conventional (fossil & nuclear)	billion \$	193.8	79.9	56.6	26.5	356.9	billion \$/a	9.2
Renewables	billion \$	148.9	637.3	858.1	993.8	2,638.1	billion \$/a	67.6
Biomass	billion \$	46.0	70.8	134.1	153.0	403.9	billion \$/a	10.4
Hydro	billion \$	60.4	69.3	53.9	52.3	235.8	billion \$/a	6.0
Wind	billion \$	25.2	279.9	343.1	475.0	1,123.2	billion \$/a	28.8
PV	billion \$	11.4	130.9	148.9	153.6	444.8	billion \$/a	11.4
Geothermal	billion \$	5.9	68.8	127.9	128.2	330.8	billion \$/a	8.5
Solar thermal power plants	billion \$	0.0	5.9	21.3	13.9	41.1	billion \$/a	1.1
Ocean energy	billion \$	0.0	11.7	28.9	17.9	58.4	billion \$/a	1.5
<b>ADV E[R]</b>								
Fossil (w/o CHP)	billion \$	32.5	11.6	60.6	28.4	133.1	billion \$/a	3.4
Nuclear	billion \$	23.3	0.0	0.0	0.0	23.3	billion \$/a	0.6
CHP (fossil + renewable)	billion \$	175.8	172.8	231.3	265.1	865.0	billion \$/a	22.2
Renewables (w/o CHP)	billion \$	114.5	781.5	1,071.9	1,425.5	3,393.4	billion \$/a	87.0
<b>Total</b>	<b>billion \$</b>	<b>346.2</b>	<b>965.9</b>	<b>1,363.8</b>	<b>1,738.9</b>	<b>4,414.8</b>	<b>billion \$/a</b>	<b>113.2</b>
Conventional (fossil & nuclear)	billion \$	196.7	76.4	86.6	28.4	388.1	billion \$/a	10.0
Renewables	billion \$	149.4	889.6	1,277.2	1,710.5	4,026.7	billion \$/a	103.2
Biomass	billion \$	46.0	70.8	134.1	163.1	414.0	billion \$/a	10.6
Hydro	billion \$	60.4	69.3	53.9	52.3	235.8	billion \$/a	6.0
Wind	billion \$	25.8	424.8	552.3	916.2	1,919.0	billion \$/a	49.2
PV	billion \$	11.4	195.8	253.8	278.1	739.1	billion \$/a	19.0
Geothermal	billion \$	5.9	101.9	204.6	264.8	577.2	billion \$/a	14.8
Solar thermal power plants	billion \$	0.0	10.8	37.5	13.1	61.4	billion \$/a	1.6
Ocean energy	billion \$	0.0	16.2	41.1	23.0	80.2	billion \$/a	2.1

Table 13.7.23: Eastern Europe/Eurasia: Investments in renewable heat generation

REF	UNIT	2012-2020	2021-2030	2031-2040	2041-2050	2012-2050	UNIT	ANNUAL AVERAGE 2012-2050
Heat pumps	billion \$	1.5	1.9	1.1	1.5	5.9	billion \$/a	0.2
Deep geothermal	billion \$	0.0	0.0	0.0	0.0	0.1	billion \$/a	0.0
Solar thermal	billion \$	0.6	0.7	0.7	0.7	2.7	billion \$/a	0.1
Biomass	billion \$	91.8	55.8	64.0	32.3	243.9	billion \$/a	6.3
<b>Total</b>	<b>billion \$</b>	<b>93.9</b>	<b>58.3</b>	<b>65.8</b>	<b>34.6</b>	<b>252.6</b>	<b>billion \$/a</b>	<b>6.5</b>
<b>E[R]</b>								
Heat pumps	billion \$	13.5	118.3	234.9	201.8	568.5	billion \$/a	14.6
Deep geothermal	billion \$	2.5	17.9	202.6	157.4	380.5	billion \$/a	9.8
Solar thermal	billion \$	10.5	123.5	182.0	131.1	447.1	billion \$/a	11.5
Biomass	billion \$	125.6	119.3	112.4	39.3	396.7	billion \$/a	10.2
<b>Total</b>	<b>billion \$</b>	<b>152.2</b>	<b>378.9</b>	<b>731.9</b>	<b>529.7</b>	<b>1,792.7</b>	<b>billion \$/a</b>	<b>46.0</b>
<b>ADV E[R]</b>								
Heat pumps	billion \$	13.5	118.3	265.3	243.5	640.6	billion \$/a	16.4
Deep geothermal	billion \$	2.5	17.9	201.9	166.1	388.5	billion \$/a	10.0
Solar thermal	billion \$	10.5	123.5	181.6	133.0	448.6	billion \$/a	11.5
Biomass	billion \$	125.6	119.3	112.1	20.6	377.6	billion \$/a	9.7
<b>Total</b>	<b>billion \$</b>	<b>152.2</b>	<b>378.9</b>	<b>760.9</b>	<b>563.3</b>	<b>1,855.3</b>	<b>billion \$/a</b>	<b>47.6</b>

Table 13.7.24: Eastern Europe/Eurasia Total employment in the energy sector THOUSAND JOBS

By sector	REFERENCE SCENARIO				ADV E[R] SCENARIO	
	2015	2020	2025	2030	2020	2030
Construction and installation	88	104	83	81	324	685
Manufacturing	32	40	37	42	140	364
Operations and maintenance	318	336	340	319	403	557
Fuel supply (domestic)	1,047	838	754	707	896	844
Coal and gas export	234.9	288.1	311.7	334.3	157.7	142.5
Solar and geothermal heat	1	2	2	2	92	437
<b>Total jobs (thousands)</b>	<b>1,720</b>	<b>1,609</b>	<b>1,527</b>	<b>1,485</b>	<b>2,003</b>	<b>3,030</b>
<b>By technology</b>						
Coal	752	586	465	407	356	173
Gas, oil & diesel	631	657	701	736	646	642
Nuclear	104	115	101	83	70	71
<b>Renewable</b>	<b>234</b>	<b>250</b>	<b>260</b>	<b>258</b>	<b>930</b>	<b>2,144</b>
Biomass	110	126	134	137	393	562
Hydro	93	94	93	89	94	81
Wind	12	15.4	17.6	20.6	197	553
PV	17.0	11.8	11.0	8.9	142	470
Geothermal power	1.0	1.4	1.4	1.2	7	25
Solar thermal power	-	-	-	-	1.4	4.9
Ocean	-	-	-	0.13	4	10.8
Solar - heat	0.7	1.2	1.2	1.0	61	282
Geothermal & heat pump	0.4	0.8	0.8	0.6	31	155
<b>Total jobs (thousands)</b>	<b>1,720</b>	<b>1,609</b>	<b>1,527</b>	<b>1,485</b>	<b>2,003</b>	<b>3,030</b>

# INDIA: REFERENCE SCENARIO

**Table 13.8.1 India: Electricity generation TWh/a**

	2012	2020	2025	2030	2040	2050
<b>Power plants</b>	<b>1,128</b>	<b>1,734</b>	<b>2,280</b>	<b>2,826</b>	<b>4,063</b>	<b>5,184</b>
Hard coal (& non-renewable waste)	642	993	1,314	1,625	2,316	2,957
Lignite	158	228	274	328	473	624
Gas	0	145	216	287	484	601
of which from H <sub>2</sub>	0	0	0	0	0	0
Oil	23	19	17	15	9	5
Diesel	0	0	0	0	0	0
Nuclear	33	64	99	134	205	277
Biomass (& renewable waste)	20	42	50	59	75	92
Hydro	126	162	196	231	307	383
Wind	28	60	78	96	124	152
of which wind offshore	0	0	1	3	6	9
PV	2	21	35	49	68	91
Geothermal	0	0	0	1	1	1
Solar thermal power plants	0	0	0	0	1	1
Ocean energy	0	0	0	0	1	1
<b>Combined heat and power plants</b>	<b>0</b>	<b>0</b>	<b>0</b>	<b>0</b>	<b>0</b>	<b>0</b>
Hard coal (& non-renewable waste)	0	0	0	0	0	0
Lignite	0	0	0	0	0	0
Gas	0	0	0	0	0	0
of which from H <sub>2</sub>	0	0	0	0	0	0
Oil	0	0	0	0	0	0
Biomass (& renewable waste)	0	0	0	0	0	0
Geothermal	0	0	0	0	0	0
Hydrogen	0	0	0	0	0	0
<b>CHP by producer</b>	<b>0</b>	<b>0</b>	<b>0</b>	<b>0</b>	<b>0</b>	<b>0</b>
Main activity producers	0	0	0	0	0	0
Autoproducers	0	0	0	0	0	0
<b>Total generation</b>	<b>1,128</b>	<b>1,734</b>	<b>2,280</b>	<b>2,826</b>	<b>4,063</b>	<b>5,184</b>
Fossil	919	1,385	1,820	2,256	3,282	4,187
Hard coal (& non-renewable waste)	642	993	1,314	1,625	2,316	2,957
Lignite	158	228	274	328	473	624
Gas	0	145	216	287	484	601
Oil	23	19	17	15	9	5
Diesel	0	0	0	0	0	0
Nuclear	33	64	99	134	205	277
Hydrogen	0	0	0	0	0	0
of which renewable H <sub>2</sub>	0	0	0	0	0	0
<b>Renewables (w/o renewable hydrogen)</b>	<b>176</b>	<b>286</b>	<b>361</b>	<b>436</b>	<b>576</b>	<b>721</b>
Hydro	126	162	196	231	307	383
Wind	28	60	78	96	124	152
PV	2	21	35	49	68	91
Biomass (& renewable waste)	20	42	50	59	75	92
Geothermal	0	0	0	1	1	1
Solar thermal power plants	0	0	0	0	1	1
Ocean energy	0	0	0	0	1	1
Distribution losses	193	288	379	470	676	878
Own consumption electricity	71	153	198	242	341	351
Electricity for hydrogen production	0	0	0	0	0	0
Electricity for synfuel production	0	0	0	0	0	0
<b>Final energy consumption (electricity)</b>	<b>869</b>	<b>1,298</b>	<b>1,709</b>	<b>2,119</b>	<b>3,051</b>	<b>3,961</b>
Fluctuating RES (PV, Wind, Ocean)	30	81	113	145	192	244
Share of fluctuating RES	3%	5%	5%	5%	5%	5%
<b>RES share (domestic generation)</b>	<b>16%</b>	<b>16%</b>	<b>16%</b>	<b>15%</b>	<b>14%</b>	<b>14%</b>

**Table 13.8.2 India: Final energy consumption in transport PJ/a**

	2012	2020	2025	2030	2040	2050
<b>Road</b>	<b>2,811</b>	<b>4,490</b>	<b>6,326</b>	<b>8,147</b>	<b>10,031</b>	<b>17,844</b>
Fossil fuels	2,734	4,291	6,004	7,702	12,269	16,677
Biofuels	9	48	79	109	284	504
Synfuels	0	0	0	0	0	0
Natural gas	69	150	240	330	458	620
Hydrogen	0	0	0	0	0	0
Electricity	0	1	3	5	20	45
<b>Rail</b>	<b>168</b>	<b>226</b>	<b>261</b>	<b>297</b>	<b>356</b>	<b>387</b>
Fossil fuels	112	151	181	211	266	300
Biofuels	0	0	0	0	0	0
Synfuels	0	0	0	0	0	0
Electricity	56	75	81	86	90	87
<b>Navigation</b>	<b>29</b>	<b>57</b>	<b>72</b>	<b>92</b>	<b>132</b>	<b>170</b>
Fossil fuels	29	57	72	92	132	170
Biofuels	0	0	0	0	0	0
Synfuels	0	0	0	0	0	0
<b>Aviation</b>	<b>71</b>	<b>132</b>	<b>175</b>	<b>227</b>	<b>379</b>	<b>632</b>
Fossil fuels	71	132	175	227	379	632
Biofuels	0	0	0	0	0	0
Synfuels	0	0	0	0	0	0
<b>Total (incl. pipelines)</b>	<b>3,078</b>	<b>4,905</b>	<b>6,834</b>	<b>8,762</b>	<b>13,898</b>	<b>19,033</b>
Fossil fuels	2,945	4,631	6,431	8,232	13,045	17,779
Biofuels (incl. biogas)	9	48	79	109	284	504
Synfuels	0	0	0	0	0	0
Natural gas	69	150	240	330	458	620
Hydrogen	0	0	0	0	0	0
Electricity	56	76	84	91	110	131
<b>Total RES</b>	<b>17</b>	<b>60</b>	<b>92</b>	<b>123</b>	<b>300</b>	<b>522</b>
<b>RES share</b>	<b>1%</b>	<b>1%</b>	<b>1%</b>	<b>1%</b>	<b>2%</b>	<b>3%</b>

**Table 13.8.3 India: Heat supply PJ/a**

	2012	2020	2025	2030	2040	2050
<b>District heating plants</b>	<b>0</b>	<b>0</b>	<b>0</b>	<b>0</b>	<b>0</b>	<b>0</b>
Fossil fuels	0	0	0	0	0	0
Biomass	0	0	0	0	0	0
Solar collectors	0	0	0	0	0	0
Geothermal	0	0	0	0	0	0
<b>Heat from CHP<sup>1</sup></b>	<b>0</b>	<b>0</b>	<b>0</b>	<b>0</b>	<b>0</b>	<b>0</b>
Fossil fuels	0	0	0	0	0	0
Biomass	0	0	0	0	0	0
Geothermal	0	0	0	0	0	0
Hydrogen	0	0	0	0	0	0
<b>Direct heating</b>	<b>10,904</b>	<b>13,571</b>	<b>15,365</b>	<b>17,188</b>	<b>20,315</b>	<b>24,268</b>
Fossil fuels	5,172	7,367	8,958	10,577	13,631	17,380
Biomass	5,433	5,868	6,042	6,219	6,223	6,334
Solar collectors	20	54	80	106	171	261
Geothermal	0	0	0	0	0	0
Heat pumps <sup>2</sup>	0	0	1	1	1	2
Electric direct heating	279	282	284	285	288	291
Hydrogen	0	0	0	0	0	0
<b>Total heat supply<sup>3</sup></b>	<b>10,904</b>	<b>13,571</b>	<b>15,365</b>	<b>17,188</b>	<b>20,315</b>	<b>24,268</b>
Fossil fuels	5,172	7,367	8,958	10,577	13,631	17,380
Biomass	5,433	5,868	6,042	6,219	6,223	6,334
Solar collectors	20	54	80	106	171	261
Geothermal	0	0	0	0	0	0
Heat pumps <sup>2</sup>	0	0	1	1	1	2
Electric direct heating	279	282	284	285	288	291
Hydrogen	0	0	0	0	0	0
<b>RES share (including RES electricity)</b>	<b>50%</b>	<b>44%</b>	<b>40%</b>	<b>37%</b>	<b>32%</b>	<b>27%</b>

<sup>1</sup> public CHP and CHP autoproduction / <sup>2</sup> heat from ambient energy and electricity use / <sup>3</sup> incl. process heat, cooking

**Table 13.8.4: India: Installed capacity GW**

	2012	2020	2025	2030	2040	2050
<b>Total generation</b>	<b>235</b>	<b>413</b>	<b>554</b>	<b>695</b>	<b>985</b>	<b>1,190</b>
<b>Fossil</b>	<b>162</b>	<b>291</b>	<b>397</b>	<b>502</b>	<b>729</b>	<b>873</b>
Hard coal (& non-renewable waste)	106	193	267	340	495	594
Lignite	26	44	56	69	101	125
Gas (w/o H <sub>2</sub> )	23	48	65	85	127	150
Oil	7	9	8	6	4	4
Diesel	0	0	0	0	0	0
Nuclear	5	10	14	19	29	40
Hydrogen (fuel cells, gas power plants, gas CHP)	0	0	0	0	0	0
<b>Renewables</b>	<b>68</b>	<b>112</b>	<b>143</b>	<b>173</b>	<b>226</b>	<b>277</b>
Hydro	42	54	65	76	101	126
Wind	18	34	42	50	62	72
of which wind offshore	0	0	0	1	2	3
PV	1	15	25	35	47	59
Biomass (& renewable waste)	6	9	11	12	15	19
Geothermal	0	0	0	0	0	0
Solar thermal power plants	0	0	0	0	0	0
Ocean energy	0	0	0	0	0	0
Fluctuating RES (PV, Wind, Ocean)	20	49	67	85	109	132
Share of fluctuating RES	8%	12%	12%	12%	11%	11%
<b>RES share (domestic generation)</b>	<b>29%</b>	<b>27%</b>	<b>26%</b>	<b>25%</b>	<b>23%</b>	<b>23%</b>

**Table 13.8.5: India: Final energy demand PJ/a**

	2012	2020	2025	2030	2040	2050
<b>Total (incl. non-energy use)</b>	<b>21,417</b>	<b>28,467</b>	<b>34,161</b>	<b>39,855</b>	<b>51,982</b>	<b>64,887</b>
<b>Total energy use</b>	<b>19,925</b>	<b>26,362</b>	<b>31,738</b>	<b>37,113</b>	<b>48,777</b>	<b>61,219</b>
<b>Transport</b>	<b>3,078</b>	<b>4,905</b>	<b>6,834</b>	<b>8,762</b>	<b>13,898</b>	<b>19,033</b>
Oil products	2,945	4,631	6,431	8,232	13,045	17,779
Natural gas	69	150	240	330	458	620
Biofuels	9	48	79	109	284	504
Synfuels	0	0	0	0	0	0
Electricity	56	76	84	91	110	131
RES electricity	9	13	13	14	16	18
Hydrogen	0	0	0	0	0	0
<b>RES share Transport</b>	<b>1%</b>	<b>1%</b>	<b>1%</b>	<b>1%</b>	<b>2%</b>	<b>3%</b>
<b>Industry</b>	<b>7,034</b>	<b>10,443</b>	<b>12,814</b>	<b>15,186</b>	<b>19,767</b>	<b>25,340</b>
Electricity	1,381	2,010	2,535	3,059	4,221	5,684
RES electricity	216	331	401	472	598	792
Public district heat	0	0	0	0	0	0
RES district heat	0	0	0	0	0	0
Hard coal & lignite	2,926	4,744	5,819	6,893	8,810	11,055
Oil products	789	1,182	1,385	1,587	1,978	2,439
Gas	684	966	1,299	1,631	2,279	3,131
Solar	1	12	19	27	41	61
Biomass	1,254	1,528	1,759	1,989	2,437	2,958
Geothermal	0	0	0	0	0	0
Hydrogen	0	0	0	0	0	0
<b>RES share Industry</b>	<b>21%</b>	<b>18%</b>	<b>17%</b>	<b>16%</b>	<b>16%</b>	<b>15%</b>
<b>Other Sectors</b>	<b>9,813</b>	<b>11,014</b>	<b>12,089</b>	<b>13,165</b>	<b>15,112</b>	<b>16,846</b>
Electricity	1,692	2,588	3,533	4,478	6,654	8,434
RES electricity	264	426	559	690	943	1,173
Public district heat	0	0	0	0	0	0
RES district heat	0					



**Table 13.8.8 India: Electricity generation TWh/a**

	2012	2020	2025	2030	2040	2050
<b>Power plants</b>	<b>1,128</b>	<b>1,711</b>	<b>2,230</b>	<b>2,836</b>	<b>4,277</b>	<b>5,630</b>
Hard coal (& non-renewable waste)	642	890	854	727	396	123
Lignite	158	213	213	190	90	0
Gas	95	155	287	283	259	182
of which from H <sub>2</sub>	0	0	0	0	0	0
Oil	23	15	14	5	0	0
Diesel	0	0	0	0	0	0
Nuclear	33	53	48	43	24	0
Biomass (& renewable waste)	20	55	70	70	69	68
Hydro	126	162	196	199	205	210
Wind	28	78	305	653	1,451	2,230
of which wind offshore	0	1	32	111	292	430
Geothermal	0	2	88	214	425	921
Solar thermal power plants	0	2	21	186	615	970
Ocean energy	0	0	3	30	90	150
<b>Combined heat and power plants</b>	<b>0</b>	<b>20</b>	<b>66</b>	<b>118</b>	<b>307</b>	<b>541</b>
Hard coal (& non-renewable waste)	0	0	0	0	0	0
Lignite	0	0	0	0	0	0
Gas	0	10	30	44	74	98
of which from H <sub>2</sub>	0	0	0	0	0	0
Oil	0	0	0	0	0	0
Biomass (& renewable waste)	0	10	33	59	154	271
Geothermal	0	0	4	14	62	122
Hydrogen	0	0	0	1	17	51
<b>CHP by producer</b>						
Main activity producers	0	0	5	10	20	30
Autoproducers	0	20	61	108	287	511
<b>Total generation</b>	<b>1,128</b>	<b>1,731</b>	<b>2,296</b>	<b>2,954</b>	<b>4,584</b>	<b>6,171</b>
Fossil	919	1,283	1,396	1,249	820	400
Hard coal (& non-renewable waste)	642	890	854	727	396	123
Lignite	158	213	213	190	90	0
Gas	95	165	316	327	333	277
Oil	23	15	14	5	0	0
Diesel	0	0	0	0	0	0
Nuclear	33	53	48	43	24	0
Hydrogen	0	0	0	1	17	53
of which renewable H <sub>2</sub>	0	0	0	1	14	50
<b>Renewables (w/o renewable hydrogen)</b>	<b>176</b>	<b>395</b>	<b>852</b>	<b>1,661</b>	<b>3,724</b>	<b>5,718</b>
Hydro	126	162	196	199	205	210
Wind	28	78	305	653	1,451	2,230
PV	2	88	214	425	921	1,430
Biomass (& renewable waste)	20	65	103	129	222	338
Geothermal	0	1	9	39	220	390
Solar thermal power plants	0	2	21	186	615	970
Ocean energy	0	0	3	30	90	150
Distribution losses	193	278	349	420	496	518
Own consumption electricity	71	143	163	167	161	125
Electricity for hydrogen production	0	0	2	30	258	618
Electricity for synfuel production	0	0	0	0	0	0
<b>Final energy consumption (electricity)</b>	<b>869</b>	<b>1,315</b>	<b>1,787</b>	<b>2,343</b>	<b>3,675</b>	<b>4,916</b>
Fluctuating RES (PV, Wind, Ocean)	30	166	522	1,108	2,462	3,810
Share of fluctuating RES	3%	10%	23%	38%	54%	62%
<b>RES share (domestic generation)</b>	<b>16%</b>	<b>23%</b>	<b>37%</b>	<b>56%</b>	<b>82%</b>	<b>93%</b>

**Table 13.8.9 India: Final energy consumption in transport PJ/a**

	2012	2020	2025	2030	2040	2050
<b>Road</b>	<b>2,811</b>	<b>4,390</b>	<b>5,839</b>	<b>7,093</b>	<b>8,209</b>	<b>8,477</b>
Fossil fuels	2,734	4,149	5,433	6,278	5,786	3,570
Biofuels	9	68	127	221	367	394
Synfuels	0	0	0	0	0	0
Natural gas	69	171	248	323	353	391
Hydrogen	0	0	5	64	444	840
Electricity	0	1	25	207	1,260	3,283
<b>Rail</b>	<b>168</b>	<b>228</b>	<b>273</b>	<b>314</b>	<b>390</b>	<b>450</b>
Fossil fuels	112	140	154	133	104	59
Biofuels	0	7	8	32	26	32
Synfuels	0	0	0	0	0	0
Electricity	56	80	110	150	260	360
<b>Navigation</b>	<b>29</b>	<b>57</b>	<b>71</b>	<b>87</b>	<b>112</b>	<b>130</b>
Fossil fuels	29	54	68	80	90	84
Biofuels	0	3	4	8	22	46
Synfuels	0	0	0	0	0	0
<b>Aviation</b>	<b>71</b>	<b>132</b>	<b>173</b>	<b>216</b>	<b>322</b>	<b>442</b>
Fossil fuels	71	132	168	203	258	288
Biofuels	0	0	5	13	64	155
Synfuels	0	0	0	0	0	0
<b>Total (incl. pipelines)</b>	<b>3,078</b>	<b>4,807</b>	<b>6,355</b>	<b>7,711</b>	<b>9,034</b>	<b>9,500</b>
Fossil fuels	2,945	4,476	5,824	6,693	6,237	4,000
Biofuels (incl. biogas)	9	78	144	273	480	625
Synfuels	0	0	0	0	0	0
Natural gas	69	171	248	323	353	391
Hydrogen	0	0	5	64	444	840
Electricity	56	82	135	357	1,520	3,643
<b>Total RES</b>	<b>17</b>	<b>97</b>	<b>196</b>	<b>510</b>	<b>2,081</b>	<b>4,815</b>
<b>RES share</b>	<b>1%</b>	<b>2%</b>	<b>3%</b>	<b>7%</b>	<b>23%</b>	<b>51%</b>

**Table 13.8.10 India: Heat supply PJ/a**

	2012	2020	2025	2030	2040	2050
<b>District heating plants</b>	<b>0</b>	<b>0</b>	<b>38</b>	<b>129</b>	<b>414</b>	<b>796</b>
Fossil fuels	0	0	0	0	0	0
Biomass	0	0	29	91	186	199
Solar collectors	0	0	9	32	182	470
Geothermal	0	0	1	6	46	127
<b>Heat from CHP<sup>1</sup></b>	<b>0</b>	<b>84</b>	<b>283</b>	<b>550</b>	<b>1,628</b>	<b>3,010</b>
Fossil fuels	0	35	103	153	254	329
Biomass	0	45	148	265	694	1,222
Geothermal	0	4	32	123	558	1,089
Hydrogen	0	0	0	8	123	371
<b>Direct heating</b>	<b>10,904</b>	<b>13,216</b>	<b>14,054</b>	<b>14,955</b>	<b>15,512</b>	<b>14,289</b>
Fossil fuels	5,172	6,882	6,813	6,368	4,637	1,765
Biomass	5,433	5,787	5,779	5,549	4,800	3,902
Solar collectors	20	82	514	1,145	2,209	2,850
Geothermal	0	0	30	124	274	509
Heat pumps <sup>2</sup>	0	7	112	387	800	1,216
Electric direct heating	279	457	806	1,381	2,751	3,804
Hydrogen	0	0	0	0	41	242
<b>Total heat supply<sup>3</sup></b>	<b>10,904</b>	<b>13,300</b>	<b>14,375</b>	<b>15,633</b>	<b>17,555</b>	<b>18,096</b>
Fossil fuels	5,172	6,917	6,916	6,521	4,891	2,094
Biomass	5,433	5,832	5,965	5,905	5,680	5,323
Solar collectors	20	82	522	1,177	2,391	3,320
Geothermal	0	4	63	254	878	1,725
Heat pumps <sup>2</sup>	0	7	112	387	800	1,216
Electric direct heating	279	457	806	1,381	2,751	3,804
Hydrogen	0	0	0	8	164	614
<b>RES share (including RES electricity)</b>	<b>50%</b>	<b>45%</b>	<b>49%</b>	<b>55%</b>	<b>69%</b>	<b>87%</b>

<sup>1</sup> public CHP and CHP autoproduction / <sup>2</sup> heat from ambient energy and electricity use / <sup>3</sup> incl. process heat, cooking

**Table 13.8.10 India: Installed capacity GW**

	2012	2020	2025	2030	2040	2050
<b>Total generation</b>	<b>235</b>	<b>451</b>	<b>692</b>	<b>1,064</b>	<b>1,815</b>	<b>2,447</b>
<b>Fossil</b>	<b>162</b>	<b>268</b>	<b>280</b>	<b>283</b>	<b>256</b>	<b>193</b>
Hard coal (& non-renewable waste)	106	173	161	151	120	61
Lignite	26	39	39	35	19	0
Gas (w/o H <sub>2</sub> )	23	49	73	94	116	131
Oil	7	7	7	3	0	0
Diesel	0	0	0	0	0	0
Nuclear	5	8	7	6	3	0
Hydrogen (fuel cells, gas power plants, gas CHP)	0	0	0	0	5	14
<b>Renewables</b>	<b>68</b>	<b>176</b>	<b>405</b>	<b>775</b>	<b>1,551</b>	<b>2,240</b>
Hydro	42	54	65	66	68	69
Wind	18	43	157	320	667	941
of which wind offshore	0	0	10	35	87	123
PV	1	64	153	302	576	841
Biomass (& renewable waste)	6	14	22	30	51	79
Geothermal	0	0	2	7	26	64
Solar thermal power plants	0	1	5	40	125	194
Ocean energy	0	0	1	10	28	52
Fluctuating RES (PV, Wind, Ocean)	20	107	311	632	1,271	1,834
Share of fluctuating RES	8%	24%	45%	59%	70%	75%
<b>RES share (domestic generation)</b>	<b>29%</b>	<b>39%</b>	<b>59%</b>	<b>73%</b>	<b>85%</b>	<b>92%</b>

**Table 13.8.12 India: Final energy demand PJ/a**

	2012	2020	2025	2030	2040	2050
<b>Total (incl. non-energy use)</b>	<b>21,417</b>	<b>27,719</b>	<b>31,452</b>	<b>34,757</b>	<b>38,487</b>	<b>38,599</b>
<b>Total energy use</b>	<b>19,925</b>	<b>25,656</b>	<b>29,150</b>	<b>32,289</b>	<b>35,731</b>	<b>35,599</b>
<b>Transport</b>	<b>3,078</b>	<b>4,807</b>	<b>6,355</b>	<b>7,711</b>	<b>9,034</b>	<b>9,500</b>
Oil products	2,945	4,476	5,824	6,693	6,237	4,000
Natural gas	69	171	248	323	353	391
Biofuels	9	78	144	273	480	625
Synfuels	0	0	0	0	0	0
Electricity	56	82	135	357	1,520	3,643
RES electricity	9	19	50	201	1,239	3,405
Hydrogen	0	0	5	64	444	840
<b>RES share Transport</b>	<b>1%</b>	<b>2%</b>	<b>3%</b>	<b>7%</b>	<b>23%</b>	<b>51%</b>
<b>Industry</b>	<b>7,034</b>	<b>10,068</b>	<b>11,164</b>	<b>12,196</b>	<b>13,366</b>	<b>12,881</b>
Electricity	1,381	2,070	2,692	3,386	4,946	6,209
RES electricity	216	472	999	1,905	4,033	5,803
Public district heat	0	0	43	124	286	678
RES district heat	0	0	38	115	249	657
Hard coal & lignite	2,926	4,534	4,414	4,272	2,963	469
Oil products	789	934	833	576	124	8
Gas	684	939	1,269	1,337	1,443	1,052
Solar	1	18	150	497	1,189	1,526
Biomass	1,254	1,569	1,655	1,612	1,479	1,413
Geothermal	0	5	109	391	811	1,271
Hydrogen	0	0	0	0	44	255
<b>RES share Industry</b>	<b>21%</b>	<b>20%</b>	<b>26%</b>	<b>37%</b>	<b>59%</b>	<b>85%</b>
<b>Other Sectors</b>	<b>9,813</b>	<b>10,781</b>	<b>11,630</b> </			

# INDIA: ADVANCED ENERGY [R]EVOLUTION SCENARIO

Table 13.8.15 India: Electricity generation TWh/a

	2012	2020	2025	2030	2040	2050
<b>Power plants</b>	<b>1,128</b>	<b>1,725</b>	<b>2,324</b>	<b>3,116</b>	<b>5,397</b>	<b>7,759</b>
Hard coal (& non-renewable waste)	642	890	828	573	142	0
Lignite	158	213	213	190	90	0
Gas	95	155	287	263	260	169
of which from H <sub>2</sub>	0	0	1	6	36	169
Oil	23	15	14	5	0	0
Diesel	0	0	0	0	0	0
Nuclear	33	53	48	43	24	0
Biomass (& renewable waste)	20	57	65	68	70	73
Hydro	126	162	196	199	205	210
Wind	28	84	406	926	2,269	3,570
of which wind offshore	0	3	57	183	430	635
PV	2	93	233	550	1,325	2,078
Geothermal	0	1	11	36	199	320
Solar thermal power plants	0	3	22	210	714	1,170
Ocean energy	0	0	3	33	100	170
<b>Combined heat and power plants</b>	<b>0</b>	<b>20</b>	<b>66</b>	<b>118</b>	<b>307</b>	<b>541</b>
Hard coal (& non-renewable waste)	0	0	0	0	0	0
Lignite	0	0	0	0	0	0
Gas	0	10	30	44	74	61
of which from H <sub>2</sub>	0	0	0	1	10	61
Oil	0	0	0	0	0	0
Biomass (& renewable waste)	0	10	33	59	154	271
Geothermal	0	0	4	14	62	127
Hydrogen	0	0	0	1	17	82
<b>CHP by producer</b>						
Main activity producers	0	0	5	10	20	30
Autoproducers	0	20	61	108	287	511
<b>Total generation</b>	<b>1,128</b>	<b>1,746</b>	<b>2,390</b>	<b>3,234</b>	<b>5,704</b>	<b>8,300</b>
Fossil	919	1,282	1,369	1,069	519	0
Hard coal (& non-renewable waste)	642	890	828	573	142	0
Lignite	158	213	213	190	90	0
Gas	95	165	315	321	287	0
Oil	23	15	14	5	0	0
Diesel	0	0	0	0	0	0
Nuclear	33	53	48	43	24	0
Hydrogen	0	0	2	8	64	312
of which renewable H <sub>2</sub>	0	0	1	5	58	312
<b>Renewables (w/o renewable hydrogen)</b>	<b>176</b>	<b>410</b>	<b>972</b>	<b>2,094</b>	<b>5,098</b>	<b>7,988</b>
Hydro	126	162	196	199	205	210
Wind	28	84	406	926	2,269	3,570
PV	2	93	233	550	1,325	2,078
Biomass (& renewable waste)	20	67	98	127	224	344
Geothermal	0	2	14	50	261	446
Solar thermal power plants	0	3	22	210	714	1,170
Ocean energy	0	0	3	33	100	170
Distribution losses	193	278	349	420	496	518
Own consumption electricity	71	143	163	167	161	125
Electricity for hydrogen production	0	7	28	109	650	1,652
Electricity for synfuel production	0	0	0	23	246	542
<b>Final energy consumption (electricity)</b>	<b>869</b>	<b>1,322</b>	<b>1,855</b>	<b>2,520</b>	<b>4,156</b>	<b>5,469</b>
Fluctuating RES (PV, Wind, Ocean)	30	177	642	1,508	3,694	5,818
Share of fluctuating RES	3%	10%	27%	47%	65%	70%
<b>RES share (domestic generation)</b>	<b>16%</b>	<b>23%</b>	<b>41%</b>	<b>65%</b>	<b>90%</b>	<b>100%</b>

Table 13.8.16 India: Final Energy Consumption Transport PJ/a

	2012	2020	2025	2030	2040	2050
<b>Road</b>	<b>2,811</b>	<b>4,356</b>	<b>5,595</b>	<b>6,432</b>	<b>5,557</b>	<b>4,629</b>
Fossil fuels	2,734	4,095	5,131	5,420	2,422	0
Biofuels	9	67	120	223	389	434
Synfuels	0	0	0	27	292	567
Natural gas	69	169	212	212	57	0
Hydrogen	0	18	52	194	1,013	1,224
Electricity	0	9	81	383	1,676	2,971
<b>Rail</b>	<b>168</b>	<b>234</b>	<b>325</b>	<b>450</b>	<b>894</b>	<b>1,342</b>
Fossil fuels	112	129	131	105	47	0
Biofuels	0	7	7	17	18	20
Synfuels	0	0	0	2	13	25
Electricity	56	99	186	327	816	1,297
<b>Navigation</b>	<b>29</b>	<b>57</b>	<b>71</b>	<b>87</b>	<b>112</b>	<b>130</b>
Fossil fuels	29	54	68	76	73	0
Biofuels	0	3	4	11	22	56
Synfuels	0	0	0	1	17	74
<b>Aviation</b>	<b>71</b>	<b>131</b>	<b>168</b>	<b>201</b>	<b>251</b>	<b>265</b>
Fossil fuels	71	131	163	175	163	0
Biofuels	0	0	5	23	50	115
Synfuels	0	0	0	3	38	150
<b>Total (incl. pipelines)</b>	<b>3,078</b>	<b>4,779</b>	<b>6,159</b>	<b>7,196</b>	<b>7,107</b>	<b>6,934</b>
Fossil fuels	2,945	4,409	5,493	5,775	2,705	0
Biofuels (incl. biogas)	9	76	135	273	480	625
Synfuels	0	0	0	33	360	816
Natural gas	69	169	212	212	57	0
Hydrogen	0	18	52	194	1,013	1,224
Electricity	56	107	267	709	2,492	4,268
<b>Total RES</b>	<b>17</b>	<b>106</b>	<b>265</b>	<b>881</b>	<b>3,973</b>	<b>6,934</b>
<b>RES share</b>	<b>1%</b>	<b>2%</b>	<b>4%</b>	<b>12%</b>	<b>56%</b>	<b>100%</b>

Table 13.8.17 India: Heat Supply PJ/a

	2012	2020	2025	2030	2040	2050
<b>District heating plants</b>	<b>0</b>	<b>0</b>	<b>34</b>	<b>121</b>	<b>397</b>	<b>756</b>
Fossil fuels	0	0	0	0	0	0
Biomass	0	0	26	85	179	189
Solar collectors	0	0	8	30	175	446
Geothermal	0	0	1	6	44	121
<b>Heat from CHP<sup>1</sup></b>	<b>0</b>	<b>84</b>	<b>288</b>	<b>561</b>	<b>1,654</b>	<b>3,191</b>
Fossil fuels	0	35	105	154	226	0
Biomass	0	45	151	273	709	1,251
Geothermal	0	4	32	124	559	1,136
Hydrogen	0	0	1	11	161	805
<b>Direct heating</b>	<b>10,904</b>	<b>13,216</b>	<b>14,053</b>	<b>14,951</b>	<b>15,503</b>	<b>14,147</b>
Fossil fuels	5,172	6,882	6,695	6,218	4,089	0
Biomass	5,433	5,787	5,778	5,547	4,796	3,876
Solar collectors	20	82	514	1,144	2,218	2,989
Geothermal	0	0	30	124	320	726
Heat pumps <sup>2</sup>	0	7	112	387	800	1,199
Electric direct heating	279	457	918	1,505	3,104	4,616
Hydrogen	0	0	6	25	178	741
<b>Total heat supply<sup>3</sup></b>	<b>10,904</b>	<b>13,300</b>	<b>14,375</b>	<b>15,633</b>	<b>17,555</b>	<b>18,095</b>
Fossil fuels	5,172	6,917	6,799	6,372	4,314	0
Biomass	5,433	5,832	5,955	5,905	5,684	5,316
Solar collectors	20	82	521	1,174	2,392	3,436
Geothermal	0	4	63	254	923	1,982
Heat pumps <sup>2</sup>	0	7	112	387	800	1,199
Electric direct heating	279	457	918	1,505	3,104	4,616
Hydrogen	0	0	6	25	178	741
<b>RES share (including RES electricity)</b>	<b>50%</b>	<b>45%</b>	<b>49%</b>	<b>56%</b>	<b>74%</b>	<b>100%</b>

<sup>1</sup> public CHP and CHP autoproduction / <sup>2</sup> heat from ambient energy and electricity use / <sup>3</sup> incl. process heat, cooking

Table 13.8.18: India: Installed capacity GW

	2012	2020	2025	2030	2040	2050
<b>Total generation</b>	<b>235</b>	<b>459</b>	<b>738</b>	<b>1,243</b>	<b>2,409</b>	<b>3,414</b>
<b>Fossil</b>	<b>162</b>	<b>268</b>	<b>264</b>	<b>236</b>	<b>166</b>	<b>0</b>
Hard coal (& non-renewable waste)	106	173	145	106	43	0
Lignite	26	39	39	35	19	0
Gas (w/o H <sub>2</sub> )	23	49	72	92	103	0
Oil	0	7	7	3	0	0
Diesel	0	0	0	0	0	0
Nuclear	5	8	7	6	3	0
Hydrogen (fuel cells, gas power plants, gas CHP)	0	0	0	2	21	151
<b>Renewables</b>	<b>68</b>	<b>183</b>	<b>467</b>	<b>999</b>	<b>2,218</b>	<b>3,263</b>
Hydro	42	54	65	66	66	69
Wind	18	46	206	449	1,048	1,518
of which wind offshore	0	1	18	58	128	184
PV	1	68	167	390	828	1,222
Biomass (& renewable waste)	6	14	21	29	54	67
Geothermal	0	0	2	8	43	73
Solar thermal power plants	0	1	6	46	146	234
Ocean energy	0	0	1	11	31	59
Fluctuating RES (PV, Wind, Ocean)	20	114	373	850	1,907	2,799
Share of fluctuating RES	8%	25%	51%	68%	79%	82%
<b>RES share (domestic generation)</b>	<b>29%</b>	<b>40%</b>	<b>63%</b>	<b>80%</b>	<b>92%</b>	<b>96%</b>

Table 13.8.19: India: Final energy demand PJ/a

	2012	2020	2025	2030	2040	2050
<b>Total (incl. non-energy use)</b>	<b>21,417</b>	<b>27,690</b>	<b>31,237</b>	<b>34,340</b>	<b>36,805</b>	<b>36,162</b>
<b>Total energy use</b>	<b>19,925</b>	<b>25,628</b>	<b>28,935</b>	<b>31,673</b>	<b>34,049</b>	<b>33,162</b>
<b>Transport</b>	<b>3,078</b>	<b>4,779</b>	<b>6,159</b>	<b>7,196</b>	<b>7,107</b>	<b>6,934</b>
Oil products	2,945	4,409	5,493	5,775	2,705	0
Natural gas	69	169	212	212	57	0
Biofuels	9	76	135	273	480	625
Synfuels	0	0	0	33	360	816
Electricity	56	107	267	709	2,492	4,268
RES electricity	9	25	109	460	2,252	4,268
Hydrogen	0	18	52	194	1,013	1,224
<b>RES share Transport</b>	<b>1%</b>	<b>2%</b>	<b>4%</b>	<b>12%</b>	<b>56%</b>	<b>100%</b>
<b>Industry</b>	<b>7,034</b>	<b>10,068</b>	<b>11,148</b>	<b>12,201</b>	<b>13,390</b>	<b>12,743</b>
Electricity	1,381	2,070	2,804	3,540	5,348	6,900
RES electricity	216	486	1,141	2,238	4,834	6,900
Public district heat	0	0	43	124	366	667
RES district heat	0	0	37	113	346	667
Hard coal & lignite	2,926	4,534	4,414	4,272	2,908	0
Oil products	789	934	833	571	115	0
Gas	684	939	1,124	1,170	970	0
Solar	1	18	150	497	1,189	1,688
Biomass	1,254	1,569	1,655	1,612	1,479	1,390
Geothermal	0	5	109	391	857	1,476
Hydrogen	0	0	6	24	156	641
<b>RES share Industry</b>	<b>21%</b>	<b>21%</b>	<b>28%</b>	<b>40%</b>	<b>66%</b>	<b>100%</b>

**Table 13.8.22: India: Investments in electricity generation**

REF	UNIT	2012-2020	2021-2030	2031-2040	2041-2050	2012-2050	UNIT	ANNUAL AVERAGE 2012-2050
Fossil (w/o CHP)	billion \$	215.3	354.3	418.6	487.1	1,475.3	billion \$/a	37.8
Nuclear	billion \$	18.5	37.8	44.6	51.0	151.9	billion \$/a	3.9
CHP (fossil + renewable)	billion \$	0.0	0.0	0.0	0.0	0.0	billion \$/a	0.0
Renewables (w/o CHP)	billion \$	109.8	153.0	181.7	187.3	631.7	billion \$/a	16.2
<b>Total</b>	<b>billion \$</b>	<b>343.6</b>	<b>545.1</b>	<b>644.9</b>	<b>725.4</b>	<b>2,259.0</b>	<b>billion \$/a</b>	<b>57.9</b>
Conventional (fossil & nuclear)	billion \$	233.8	392.1	463.2	538.1	1,627.3	billion \$/a	41.7
Renewables	billion \$	109.8	153.0	181.7	187.3	631.7	billion \$/a	16.2
Biomass	billion \$	10.2	13.3	17.9	19.5	60.8	billion \$/a	1.6
Hydro	billion \$	43.1	72.8	84.0	87.1	287.1	billion \$/a	7.4
Wind	billion \$	28.9	40.3	50.7	54.2	174.0	billion \$/a	4.5
PV	billion \$	27.5	26.4	28.2	24.9	107.0	billion \$/a	2.7
Geothermal	billion \$	0.0	0.0	0.3	0.4	0.7	billion \$/a	0.0
Solar thermal power plants	billion \$	0.1	0.3	0.3	0.7	1.3	billion \$/a	0.0
Ocean energy	billion \$	0.0	0.0	0.4	0.5	0.9	billion \$/a	0.0
<b>E[R]</b>								
Fossil (w/o CHP)	billion \$	176.3	28.3	24.9	114.3	343.7	billion \$/a	8.8
Nuclear	billion \$	13.0	0.0	0.0	0.0	13.0	billion \$/a	0.3
CHP (fossil + renewable)	billion \$	8.3	53.4	118.3	169.0	348.9	billion \$/a	8.9
Renewables (w/o CHP)	billion \$	216.2	1,110.4	1,567.8	1,782.8	4,677.2	billion \$/a	119.9
<b>Total</b>	<b>billion \$</b>	<b>413.8</b>	<b>1,192.0</b>	<b>1,711.0</b>	<b>2,066.0</b>	<b>5,382.8</b>	<b>billion \$/a</b>	<b>138.0</b>
Conventional (fossil & nuclear)	billion \$	192.1	37.5	34.4	127.6	391.5	billion \$/a	10.0
Renewables	billion \$	221.7	1,154.6	1,676.6	1,938.4	4,991.3	billion \$/a	128.0
Biomass	billion \$	20.4	41.3	67.0	99.1	227.8	billion \$/a	5.8
Hydro	billion \$	43.1	45.4	21.7	21.5	131.8	billion \$/a	3.4
Wind	billion \$	43.8	478.1	618.3	875.6	2,015.9	billion \$/a	51.7
PV	billion \$	111.2	311.6	344.7	393.9	1,161.4	billion \$/a	29.8
Geothermal	billion \$	0.9	52.5	190.1	177.1	420.6	billion \$/a	10.8
Solar thermal power plants	billion \$	2.2	178.3	368.3	314.7	863.4	billion \$/a	22.1
Ocean energy	billion \$	0.0	47.4	66.6	56.6	170.5	billion \$/a	4.4
<b>ADV E[R]</b>								
Fossil (w/o CHP)	billion \$	176.0	26.4	25.3	131.7	359.4	billion \$/a	9.2
Nuclear	billion \$	13.0	0.0	0.0	0.0	13.0	billion \$/a	0.3
CHP (fossil + renewable)	billion \$	8.3	53.4	118.3	168.1	348.0	billion \$/a	8.9
Renewables (w/o CHP)	billion \$	232.5	1,476.8	2,242.7	2,565.2	6,517.1	billion \$/a	167.1
<b>Total</b>	<b>billion \$</b>	<b>429.8</b>	<b>1,556.6</b>	<b>2,386.3</b>	<b>2,864.9</b>	<b>7,237.5</b>	<b>billion \$/a</b>	<b>185.6</b>
Conventional (fossil & nuclear)	billion \$	191.8	35.5	34.8	137.9	400.1	billion \$/a	10.3
Renewables	billion \$	237.9	1,521.0	2,351.5	2,727.0	6,837.4	billion \$/a	175.3
Biomass	billion \$	21.3	39.3	75.3	106.7	242.7	billion \$/a	6.2
Hydro	billion \$	43.1	45.4	21.7	21.5	131.8	billion \$/a	3.4
Wind	billion \$	49.8	700.1	1,011.4	1,377.3	3,138.6	billion \$/a	80.5
PV	billion \$	117.5	418.6	516.9	560.3	1,613.2	billion \$/a	41.4
Geothermal	billion \$	2.6	65.1	218.6	195.5	481.8	billion \$/a	12.4
Solar thermal power plants	billion \$	3.5	200.5	433.4	399.6	1,037.1	billion \$/a	26.6
Ocean energy	billion \$	0.0	52.0	74.2	66.0	192.3	billion \$/a	4.9

**Table 13.8.23: India: Investments in renewable heat generation**

REF	UNIT	2012-2020	2021-2030	2031-2040	2041-2050	2012-2050	UNIT	ANNUAL AVERAGE 2012-2050
Heat pumps	billion \$	0.1	0.2	0.2	0.3	0.8	billion \$/a	0.0
Deep geothermal	billion \$	0.0	0.0	0.0	0.0	0.0	billion \$/a	0.0
Solar thermal	billion \$	3.2	4.0	6.7	8.2	22.1	billion \$/a	0.6
Biomass	billion \$	170.0	54.8	38.0	46.7	309.5	billion \$/a	7.9
<b>Total</b>	<b>billion \$</b>	<b>173.3</b>	<b>59.0</b>	<b>44.9</b>	<b>55.2</b>	<b>332.5</b>	<b>billion \$/a</b>	<b>8.5</b>
<b>E[R]</b>								
Heat pumps	billion \$	1.1	62.9	71.8	134.0	269.9	billion \$/a	6.9
Deep geothermal	billion \$	0.0	25.2	48.5	100.5	174.2	billion \$/a	4.5
Solar thermal	billion \$	5.2	105.5	144.0	173.9	428.5	billion \$/a	11.0
Biomass	billion \$	105.6	26.7	5.5	6.9	144.6	billion \$/a	3.7
<b>Total</b>	<b>billion \$</b>	<b>111.9</b>	<b>220.3</b>	<b>269.8</b>	<b>415.3</b>	<b>1,017.2</b>	<b>billion \$/a</b>	<b>26.1</b>
<b>ADV E[R]</b>								
Heat pumps	billion \$	1.1	62.9	71.8	131.6	267.4	billion \$/a	6.9
Deep geothermal	billion \$	0.0	25.2	56.8	125.3	206.3	billion \$/a	5.3
Solar thermal	billion \$	5.2	105.2	143.7	192.1	446.1	billion \$/a	11.4
Biomass	billion \$	105.6	26.3	5.4	2.3	139.6	billion \$/a	3.6
<b>Total</b>	<b>billion \$</b>	<b>111.9</b>	<b>219.6</b>	<b>276.6</b>	<b>451.3</b>	<b>1,059.5</b>	<b>billion \$/a</b>	<b>27.2</b>

**Table 13.8.24: India: Total employment in the energy sector**

By sector	REFERENCE SCENARIO				ADV E[R] SCENARIO		
	2015	2020	2025	2030	2020	2025	2030
Construction and installation	1,226	1,622	1,427	1,204	1,459	2,532	2,283
Manufacturing	628	819	719	598	1,691	2,627	2,395
Operations and maintenance	414	560	654	621	780	1,239	1,625
Fuel supply (domestic)	2,265	2,323	2,211	1,826	2,304	2,106	1,540
Coal and gas export	-	-	-	-	-	-	-
Solar and geothermal heat	20	20	23	22	50	466	733
<b>Total jobs (thousands)</b>	<b>4,554</b>	<b>5,344</b>	<b>5,035</b>	<b>4,271</b>	<b>6,284</b>	<b>8,969</b>	<b>8,576</b>
<b>By technology</b>							
Coal	2,252	2,769	2,552	2,324	839	618	384
Gas, oil & diesel	224	299	362	343	319	437	357
Nuclear	84	118	133	120	31	26	18
<b>Renewable</b>	<b>1,993</b>	<b>2,158</b>	<b>1,989</b>	<b>1,483</b>	<b>5,095</b>	<b>7,889</b>	<b>7,817</b>
Biomass	1,515	1,584	1,433	1,076	1,688	1,659	1,312
Hydro	146	204	198	170	204	80	64
Wind	131	143	142	103	1,409	2,513	2,662
PV	177	203	189	109	1,606	2,742	2,365
Geothermal power	1.6	1.2	0.9	0.6	25	46	73
Solar thermal power	3.0	2.6	2.4	1.8	75	287	479
Ocean	-	-	0.01	1.1	39.0	95.7	128.7
Solar - heat	19.7	19.4	22.8	22.2	45	382	549
Geothermal & heat pump	-	0.4	0.3	0.3	5	83	185
<b>Total jobs (thousands)</b>	<b>4,554</b>	<b>5,344</b>	<b>5,035</b>	<b>4,271</b>	<b>6,284</b>	<b>8,969</b>	<b>8,576</b>

# OTHER ASIA: REFERENCE SCENARIO

Table 13.9.1 Other Asia: Electricity generation TWh/a

	2012	2020	2025	2030	2040	2050
<b>Power plants</b>	<b>1,180</b>	<b>1,640</b>	<b>2,021</b>	<b>2,402</b>	<b>3,487</b>	<b>4,503</b>
Hard coal (& non-renewable waste)	203	441	647	852	1,454	1,823
Lignite	143	181	201	221	260	299
Gas	467	559	643	727	1,037	1,433
of which from H <sub>2</sub>	0	0	0	0	0	0
Oil	84	69	55	38	14	4
Diesel	32	19	14	12	8	4
Nuclear	45	72	75	78	56	39
Biomass (& renewable waste)	8	33	47	62	90	127
Hydro	175	220	267	315	396	492
Wind	2	10	24	38	82	154
of which wind offshore	0	0	1	2	7	18
PV	1	8	14	20	33	51
Geothermal	20	27	33	39	55	74
Solar thermal power plants	0	0	0	1	1	3
Ocean energy	0	0	0	0	0	0
<b>Combined heat and power plants</b>	<b>39</b>	<b>47</b>	<b>50</b>	<b>52</b>	<b>57</b>	<b>64</b>
Hard coal (& non-renewable waste)	28	33	34	35	37	40
Lignite	5	6	6	7	7	8
Gas	4	6	8	9	11	15
of which from H <sub>2</sub>	0	0	0	0	0	0
Oil	2	2	2	2	2	1
Biomass (& renewable waste)	0	0	0	0	0	0
Geothermal	0	0	0	0	0	0
Hydrogen	0	0	0	0	0	0
CHP by producer						
Main activity producers	8	10	11	11	12	14
Autoproducers	31	37	39	41	45	50
<b>Total generation</b>	<b>1,219</b>	<b>1,687</b>	<b>2,071</b>	<b>2,454</b>	<b>3,544</b>	<b>4,567</b>
Fossil	969	1,317	1,609	1,901	2,830	3,627
Hard coal (& non-renewable waste)	231	474	680	887	1,490	1,863
Lignite	147	187	207	227	267	307
Gas	471	566	651	736	1,048	1,447
Oil	87	71	57	40	16	6
Diesel	32	19	14	12	8	4
Nuclear	45	72	75	78	56	39
Hydrogen	0	0	0	0	0	0
of which renewable H <sub>2</sub>	0	0	0	0	0	0
<b>Renewables (w/o renewable hydrogen)</b>	<b>206</b>	<b>298</b>	<b>386</b>	<b>475</b>	<b>658</b>	<b>901</b>
Hydro	175	220	267	315	396	492
Wind	2	10	24	38	82	154
PV	1	8	14	20	33	51
Biomass (& renewable waste)	8	33	47	62	90	127
Geothermal	20	27	33	39	55	74
Solar thermal power plants	0	0	0	1	1	3
Ocean energy	0	0	0	0	0	0
Distribution losses	99	137	168	199	288	374
Own consumption electricity	54	68	83	98	135	135
Electricity for hydrogen production	0	0	0	0	0	0
Electricity for synfuel production	0	0	0	0	0	0
<b>Final energy consumption (electricity)</b>	<b>1,081</b>	<b>1,497</b>	<b>1,835</b>	<b>2,172</b>	<b>3,137</b>	<b>4,074</b>
Fluctuating RES (PV, Wind, Ocean)	3	18	38	58	115	205
Share of fluctuating RES	0%	1%	2%	2%	3%	4%
<b>RES share (domestic generation)</b>	<b>17%</b>	<b>18%</b>	<b>19%</b>	<b>19%</b>	<b>19%</b>	<b>20%</b>

Table 13.9.2 Other Asia: Final energy consumption in transport PJ/a

	2012	2020	2025	2030	2040	2050
<b>Road</b>	<b>5,471</b>	<b>6,863</b>	<b>7,738</b>	<b>8,601</b>	<b>10,138</b>	<b>10,927</b>
Fossil fuels	5,143	6,414	7,227	8,029	9,264	9,702
Biofuels	79	198	237	274	381	457
Synfuels	0	0	0	0	0	0
Natural gas	248	249	272	295	489	759
Hydrogen	0	0	0	0	0	0
Electricity	1	1	2	3	5	8
<b>Rail</b>	<b>65</b>	<b>89</b>	<b>105</b>	<b>122</b>	<b>159</b>	<b>199</b>
Fossil fuels	50	68	81	93	118	142
Biofuels	0	0	0	0	0	0
Synfuels	0	0	0	0	0	0
Electricity	15	20	25	29	42	56
<b>Navigation</b>	<b>177</b>	<b>228</b>	<b>264</b>	<b>300</b>	<b>372</b>	<b>444</b>
Fossil fuels	177	228	264	300	372	444
Biofuels	0	0	0	0	0	0
Synfuels	0	0	0	0	0	0
<b>Aviation</b>	<b>172</b>	<b>263</b>	<b>318</b>	<b>384</b>	<b>507</b>	<b>652</b>
Fossil fuels	172	263	318	384	507	652
Biofuels	0	0	0	0	0	0
Synfuels	0	0	0	0	0	0
<b>Total (incl. pipelines)</b>	<b>5,886</b>	<b>7,442</b>	<b>8,425</b>	<b>9,407</b>	<b>11,177</b>	<b>12,222</b>
Fossil fuels	5,543	6,973	7,889	8,806	10,261	10,941
Biofuels (incl. biogas)	79	198	237	274	381	457
Synfuels	0	0	0	0	0	0
Natural gas	248	249	272	295	489	759
Hydrogen	0	0	0	0	0	0
Electricity	15	21	27	32	46	64
<b>Total RES</b>	<b>82</b>	<b>202</b>	<b>242</b>	<b>280</b>	<b>390</b>	<b>470</b>
<b>RES share</b>	<b>1%</b>	<b>3%</b>	<b>3%</b>	<b>3%</b>	<b>3%</b>	<b>4%</b>

Table 13.9.3 Other Asia: Heat supply PJ/a

	2012	2020	2025	2030	2040	2050
<b>District heating plants</b>	<b>0</b>	<b>0</b>	<b>0</b>	<b>0</b>	<b>0</b>	<b>0</b>
Fossil fuels	0	0	0	0	0	0
Biomass	0	0	0	0	0	0
Solar collectors	0	0	0	0	0	0
Geothermal	0	0	0	0	0	0
<b>Heat from CHP<sup>1</sup></b>	<b>105</b>	<b>141</b>	<b>164</b>	<b>190</b>	<b>268</b>	<b>406</b>
Fossil fuels	105	141	164	190	268	406
Biomass	0	0	0	0	0	0
Geothermal	0	0	0	0	0	0
Hydrogen	0	0	0	0	0	0
<b>Direct heating</b>	<b>10,247</b>	<b>12,398</b>	<b>13,751</b>	<b>15,144</b>	<b>18,719</b>	<b>21,532</b>
Fossil fuels	5,167	6,953	8,147	9,367	12,563	15,199
Biomass	4,215	4,509	4,583	4,651	4,820	4,780
Solar collectors	0	26	41	55	96	154
Geothermal	0	0	0	0	0	0
Heat pumps <sup>2</sup>	0	0	0	0	0	0
Electric direct heating	861	910	960	1,070	1,240	1,399
Hydrogen	0	0	0	0	0	0
<b>Total heat supply<sup>3</sup></b>	<b>10,352</b>	<b>12,539</b>	<b>13,915</b>	<b>15,333</b>	<b>18,988</b>	<b>21,938</b>
Fossil fuels	5,272	7,094	8,311	9,557	12,831	15,605
Biomass	4,215	4,509	4,583	4,651	4,820	4,780
Solar collectors	0	26	41	55	96	154
Geothermal	0	0	0	0	0	0
Heat pumps <sup>2</sup>	0	0	0	0	0	0
Electric direct heating	861	910	960	1,070	1,240	1,399
Hydrogen	0	0	0	0	0	0
<b>RES share (including RES electricity)</b>	<b>42%</b>	<b>37%</b>	<b>35%</b>	<b>32%</b>	<b>27%</b>	<b>24%</b>

<sup>1</sup> public CHP and CHP autoproduction / <sup>2</sup> heat from ambient energy and electricity use / <sup>3</sup> incl. process heat, cooking

Table 13.9.4: Other Asia: Installed capacity GW

	2012	2020	2025	2030	2040	2050
<b>Total generation</b>	<b>289</b>	<b>411</b>	<b>501</b>	<b>591</b>	<b>826</b>	<b>1,067</b>
<b>Fossil</b>	<b>221</b>	<b>303</b>	<b>362</b>	<b>422</b>	<b>596</b>	<b>754</b>
Hard coal (& non-renewable waste)	41	86	122	157	253	311
Lignite	26	34	37	40	45	51
Gas (w/o H <sub>2</sub> )	109	139	163	187	270	374
Oil	33	34	32	28	19	11
Diesel	12	9	8	8	9	7
Nuclear	6	9	10	10	7	5
Hydrogen (fuel cells, gas power plants, gas CHP)	0	0	0	0	0	0
<b>Renewables</b>	<b>62</b>	<b>99</b>	<b>129</b>	<b>159</b>	<b>222</b>	<b>308</b>
Hydro	52	74	90	107	135	168
Wind	1	5	11	16	34	62
of which wind offshore	0	0	0	0	1	2
PV	1	6	11	15	25	39
Biomass (& renewable waste)	5	10	12	14	19	26
Geothermal	3	4	5	6	8	11
Solar thermal power plants	0	0	0	0	0	1
Ocean energy	0	0	0	0	0	0
Fluctuating RES (PV, Wind, Ocean)	2	11	21	32	59	102
Share of fluctuating RES	1%	3%	4%	5%	7%	10%
<b>RES share (domestic generation)</b>	<b>21%</b>	<b>24%</b>	<b>26%</b>	<b>27%</b>	<b>27%</b>	<b>29%</b>

Table 13.9.5: Other Asia: Final energy demand PJ/a

	2012	2020	2025	2030	2040	2050
<b>Total (incl. non-energy use)</b>	<b>26,182</b>	<b>31,750</b>	<b>35,545</b>	<b>39,340</b>	<b>48,317</b>	<b>55,148</b>
<b>Total energy use</b>	<b>23,024</b>	<b>28,234</b>	<b>31,690</b>	<b>35,137</b>	<b>43,545</b>	<b>50,151</b>
<b>Transport</b>	<b>5,886</b>	<b>7,442</b>	<b>8,425</b>	<b>9,407</b>	<b>11,177</b>	<b>12,222</b>
Oil products	5,543	6,973	7,889	8,806	10,261	10,941
Natural gas	248	249	272	295	489	759
Biofuels	79	198	237	274	381	457
Synfuels	0	0	0	0	0	0
Electricity	15	21	27	32	46	64
RES electricity	3	4	5	6	9	13
Hydrogen	0	0	0	0	0	0
<b>RES share Transport</b>	<b>1%</b>	<b>3%</b>	<b>3%</b>	<b>3%</b>	<b>3%</b>	<b>4%</b>
<b>Industry</b>	<b>7,331</b>	<b>9,892</b>	<b>11,385</b>	<b>12,879</b>	<b>16,602</b>	<b>19,724</b>
Electricity	1,751	2,354	2,747	3,140	4,162	5,327
RES electricity	295	416	513	607	773	1,051
Public district heat	9	9	9	10	12	13
RES district heat	0	0	0	0	0	0
Hard coal & lignite	1,922	2,592	2,911	3,230	3,892	4,034
Oil products	1,167	1,441	1,462	1,483	1,483	1,354
Gas	1,433	2,229	2,883	3,536	5,368	7,212
Solar	0	9	11	13	18	21
Biomass	1,048	1,258	1,363	1,468	1,678	1,764
Geothermal	0	0	0	0	0	0
Hydrogen	0	0	0	0	0	0
<b>RES share Industry</b>	<b>18%</b>	<b>17%</b>	<b>17%</b>	<b>16%</b>	<b>15%</b>	<b>14%</b>
<b>Other Sectors</b>	<b>9,807</b>	<b>10,900</b>	<b>11,880</b>	<b>12,851</b>	<b>15,767</b>	<b>18,205</b>
Electricity	2,125	3,014	3,831	4,649	7,083	9,275
RES electricity	358	533	715	899	1,315	1,830
Public district heat	28	35	42	48	68	

Table 13.9.8 Other Asia: Electricity generation TWh/a

	2012	2020	2025	2030	2040	2050
<b>Power plants</b>	<b>1,180</b>	<b>1,627</b>	<b>1,907</b>	<b>2,339</b>	<b>3,698</b>	<b>4,815</b>
Hard coal (& non-renewable waste)	203	379	344	206	32	0
Lignite	143	154	67	32	4	0
Gas	467	575	594	609	554	260
of which from H <sub>2</sub>	0	0	0	0	11	26
Oil	84	68	54	21	4	1
Diesel	32	15	10	8	1	0
Nuclear	45	40	35	30	12	0
Biomass (& renewable waste)	8	25	25	25	30	36
Hydro	175	225	240	250	270	300
Wind	2	74	228	490	1,136	1,666
of which wind offshore	0	3	77	167	351	500
PV	1	46	143	305	694	1,041
Geothermal	20	27	114	179	364	495
Solar thermal power plants	0	0	48	163	488	797
Ocean energy	0	0	5	20	110	220
<b>Combined heat and power plants</b>	<b>39</b>	<b>67</b>	<b>112</b>	<b>159</b>	<b>231</b>	<b>283</b>
Hard coal (& non-renewable waste)	28	31	29	27	10	4
Lignite	5	3	2	1	0	0
Gas	4	12	38	61	106	129
of which from H <sub>2</sub>	0	0	0	0	5	44
Oil	2	2	2	1	0	0
Biomass (& renewable waste)	0	12	28	45	75	94
Geothermal	0	6	14	23	39	55
Hydrogen	0	0	0	0	0	0
<b>CHP by producer</b>						
Main activity producers	8	11	19	29	46	63
Autoproducers	31	56	93	130	185	220
<b>Total generation</b>	<b>1,219</b>	<b>1,694</b>	<b>2,019</b>	<b>2,497</b>	<b>3,929</b>	<b>5,098</b>
Fossil	969	1,239	1,139	967	695	325
Hard coal (& non-renewable waste)	231	410	373	233	42	4
Lignite	147	157	69	34	4	0
Gas	471	587	631	670	644	319
Oil	87	70	56	23	4	1
Diesel	32	15	10	8	1	0
Nuclear	45	40	35	30	12	0
Hydrogen	0	0	0	0	16	70
of which renewable H <sub>2</sub>	0	0	0	0	13	65
<b>Renewables (w/o renewable hydrogen)</b>	<b>206</b>	<b>415</b>	<b>845</b>	<b>1,500</b>	<b>3,206</b>	<b>4,703</b>
Hydro	175	225	240	250	270	300
Wind	2	74	228	490	1,136	1,666
PV	1	46	143	305	694	1,041
Biomass (& renewable waste)	8	38	53	70	105	130
Geothermal	20	27	114	179	364	495
Solar thermal power plants	0	0	48	163	488	797
Ocean energy	0	0	5	20	110	220
Distribution losses	99	128	145	174	244	323
Own consumption electricity	54	64	70	73	67	45
Electricity for hydrogen production	0	0	11	95	481	1,052
Electricity for synfuel production	0	0	0	0	0	0
<b>Final energy consumption (electricity)</b>	<b>1,081</b>	<b>1,502</b>	<b>1,793</b>	<b>2,154</b>	<b>3,136</b>	<b>3,678</b>
Fluctuating RES (PV, Wind, Ocean)	3	120	376	815	1,940	2,927
Share of fluctuating RES	0%	7%	19%	33%	49%	57%
<b>RES share (domestic generation)</b>	<b>17%</b>	<b>25%</b>	<b>42%</b>	<b>60%</b>	<b>82%</b>	<b>94%</b>

Table 13.9.9 Other Asia: Final energy consumption in transport PJ/a

	2012	2020	2025	2030	2040	2050
<b>Road</b>	<b>5,471</b>	<b>6,650</b>	<b>7,034</b>	<b>7,202</b>	<b>7,129</b>	<b>5,398</b>
Fossil fuels	5,143	6,085	6,095	5,554	3,105	649
Biofuels	79	320	530	686	825	665
Synfuels	0	0	0	0	0	0
Natural gas	248	239	224	216	185	119
Hydrogen	0	0	28	244	1,141	1,843
Electricity	1	5	158	501	1,873	2,122
<b>Rail</b>	<b>65</b>	<b>83</b>	<b>89</b>	<b>108</b>	<b>136</b>	<b>160</b>
Fossil fuels	50	62	58	61	37	14
Biofuels	0	1	3	5	16	12
Synfuels	0	0	0	0	0	0
Electricity	15	20	28	43	83	134
<b>Navigation</b>	<b>177</b>	<b>200</b>	<b>209</b>	<b>235</b>	<b>213</b>	<b>221</b>
Fossil fuels	177	194	198	206	181	122
Biofuels	0	6	10	28	32	100
Synfuels	0	0	0	0	0	0
<b>Aviation</b>	<b>172</b>	<b>212</b>	<b>250</b>	<b>264</b>	<b>345</b>	<b>499</b>
Fossil fuels	172	208	238	245	293	274
Biofuels	0	4	13	18	52	224
Synfuels	0	0	0	0	0	0
<b>Total (incl. pipelines)</b>	<b>5,886</b>	<b>7,144</b>	<b>7,582</b>	<b>7,808</b>	<b>7,824</b>	<b>6,278</b>
Fossil fuels	5,543	6,548	6,588	6,067	3,616	1,059
Biofuels (incl. biogas)	79	332	556	738	925	1,000
Synfuels	0	0	0	0	0	0
Natural gas	248	239	224	216	185	119
Hydrogen	0	0	28	244	1,141	1,843
Electricity	15	25	186	544	1,956	2,256
<b>Total RES</b>	<b>82</b>	<b>338</b>	<b>646</b>	<b>1,211</b>	<b>3,463</b>	<b>4,835</b>
<b>RES share</b>	<b>1%</b>	<b>5%</b>	<b>9%</b>	<b>16%</b>	<b>44%</b>	<b>77%</b>

Table 13.9.10 Other Asia: Heat supply PJ/a

	2012	2020	2025	2030	2040	2050
<b>District heating plants</b>	<b>0</b>	<b>0</b>	<b>2</b>	<b>2</b>	<b>3</b>	<b>4</b>
Fossil fuels	0	0	0	0	0	0
Biomass	0	0	1	1	1	1
Solar collectors	0	0	0	1	1	1
Geothermal	0	0	1	1	1	1
<b>Heat from CHP<sup>1</sup></b>	<b>105</b>	<b>248</b>	<b>481</b>	<b>728</b>	<b>1,181</b>	<b>1,672</b>
Fossil fuels	105	151	227	306	397	354
Biomass	0	46	130	216	424	686
Geothermal	0	52	124	205	343	473
Hydrogen	0	0	0	0	17	159
<b>Direct heating</b>	<b>10,247</b>	<b>11,785</b>	<b>12,361</b>	<b>12,895</b>	<b>14,097</b>	<b>14,175</b>
Fossil fuels	5,167	5,775	5,511	4,980	3,850	1,577
Biomass	4,215	4,692	4,625	4,168	3,162	2,485
Solar collectors	4	107	446	1,131	2,529	3,178
Geothermal	0	182	327	485	945	1,264
Heat pumps <sup>2</sup>	0	4	93	378	759	1,549
Electric direct heating	861	1,025	1,359	1,753	2,851	3,625
Hydrogen	0	0	0	0	0	498
<b>Total heat supply<sup>3</sup></b>	<b>10,352</b>	<b>12,033</b>	<b>12,844</b>	<b>13,625</b>	<b>15,280</b>	<b>15,851</b>
Fossil fuels	5,272	5,926	5,738	5,286	4,247	1,931
Biomass	4,215	4,738	4,756	4,386	3,587	3,173
Solar collectors	4	107	446	1,131	2,530	3,179
Geothermal	0	234	451	690	1,289	1,738
Heat pumps <sup>2</sup>	0	4	93	378	759	1,549
Electric direct heating	861	1,025	1,359	1,753	2,851	3,625
Hydrogen	0	0	0	0	17	657
<b>RES share (including RES electricity)</b>	<b>42%</b>	<b>44%</b>	<b>49%</b>	<b>56%</b>	<b>69%</b>	<b>86%</b>

<sup>1</sup> public CHP and CHP autoproduction / <sup>2</sup> heat from ambient energy and electricity use / <sup>3</sup> incl. process heat, cooking

Table 13.9.10: Other Asia: Installed capacity GW

	2012	2020	2025	2030	2040	2050
<b>Total generation</b>	<b>289</b>	<b>431</b>	<b>604</b>	<b>875</b>	<b>1,595</b>	<b>2,200</b>
<b>Fossil</b>	<b>221</b>	<b>265</b>	<b>264</b>	<b>254</b>	<b>270</b>	<b>231</b>
Hard coal (& non-renewable waste)	41	68	72	55	12	1
Lignite	26	27	14	7	1	0
Gas (w/o H <sub>2</sub> )	109	129	142	171	252	229
Oil	33	34	32	16	5	2
Diesel	12	7	6	6	1	0
Nuclear	6	5	5	4	2	0
Hydrogen (fuel cells, gas power plants, gas CHP)	0	0	0	0	6	34
<b>Renewables</b>	<b>62</b>	<b>161</b>	<b>335</b>	<b>617</b>	<b>1,317</b>	<b>1,935</b>
Hydro	52	75	81	85	92	102
Wind	1	33	92	196	443	645
of which wind offshore	0	0	1	25	56	114
PV	1	36	111	235	535	801
Biomass (& renewable waste)	5	11	13	16	26	35
Geothermal	3	5	20	32	61	83
Solar thermal power plants	0	0	15	43	105	159
Ocean energy	0	0	3	10	55	110
Fluctuating RES (PV, Wind, Ocean)	2	69	205	442	1,033	1,555
Share of fluctuating RES	1%	16%	34%	50%	65%	71%
<b>RES share (domestic generation)</b>	<b>21%</b>	<b>37%</b>	<b>56%</b>	<b>71%</b>	<b>83%</b>	<b>88%</b>

Table 13.9.12: Other Asia: Final energy demand PJ/a

	2012	2020	2025	2030	2040	2050
<b>Total (incl. non-energy use)</b>	<b>26,182</b>	<b>30,298</b>	<b>31,679</b>	<b>32,479</b>	<b>33,882</b>	<b>32,860</b>
<b>Total energy use</b>	<b>23,024</b>	<b>27,120</b>	<b>26,556</b>	<b>29,050</b>	<b>30,240</b>	<b>28,841</b>
<b>Transport</b>	<b>5,886</b>	<b>7,144</b>	<b>7,582</b>	<b>7,808</b>	<b>7,824</b>	<b>6,278</b>
Oil products	5,543	6,548	6,588	6,067	3,616	1,059
Natural gas	248	239	224	216	185	119
Biofuels	79	332	556	738	925	1,000
Synfuels	0	0	0	0	0	0
Electricity	15	25	186	544	1,956	2,256
RES electricity	3	6	78	327	1,603	2,111
Hydrogen	0	0	28	244	1,141	1,843
<b>RES share Transport</b>	<b>1%</b>	<b>5%</b>	<b>9%</b>	<b>16%</b>	<b>44%</b>	<b>77%</b>
<b>Industry</b>	<b>7,331</b>	<b>9,240</b>	<b>9,771</b>	<b>10,093</b>	<b>10,826</b>	<b>10,819</b>
Electricity	1,751	2,358	2,707	3,036	3,924	4,480
RES electricity	295	578	1,133	1,860	3,215	4,191
Public district heat	9	28	91	127	194	242
RES district heat	0	11	67	103	177	224
Hard coal & lignite	1,922	2,296	1,937	1,021	196	41
Oil products	1,167	1,094	841	709	495	105
Gas	1,433	1,980	2,277	2,621	2,679	1,269
Solar	0	61	261	692	1,418	1,703
Biomass	1,048	1,260	1,306	1,292	803	658
Geothermal	0	183	350	534	1,118	1,797
Hydrogen	0	0	0	0	0	524
<b>RES share Industry</b>	<b>18%</b>	<b>23%</b>	<b>32%</b>	<b>44%</b>	<b>62%</b>	<b>84%</b>

# OTHER ASIA: ADVANCED ENERGY [R]EVOLUTION SCENARIO

Table 13.9.15 Other Asia: Electricity generation TWh/a

	2012	2020	2025	2030	2040	2050
<b>Power plants</b>	<b>1,180</b>	<b>1,629</b>	<b>1,948</b>	<b>2,465</b>	<b>4,255</b>	<b>6,298</b>
Hard coal (& non-renewable waste)	203	364	272	108	2	0
Lignite	143	154	67	32	4	0
Gas	467	590	644	639	588	305
<i>of which from H<sub>2</sub></i>	0	0	0	0	59	305
Oil	84	68	51	18	1	0
Diesel	32	15	13	11	4	0
Nuclear	45	40	35	30	12	0
Biomass (& renewable waste)	8	25	30	30	33	28
Hydro	175	225	243	253	273	300
Wind	2	74	228	505	1,253	1,988
<i>of which wind offshore</i>	0	3	77	182	397	600
PV	1	46	149	376	862	1,338
Geothermal	20	27	129	209	414	564
Solar thermal power plants	0	1	81	234	698	1,556
Ocean energy	0	0	5	20	110	220
<b>Combined heat and power plants</b>	<b>39</b>	<b>67</b>	<b>112</b>	<b>159</b>	<b>231</b>	<b>283</b>
Hard coal (& non-renewable waste)	28	31	29	27	7	0
Lignite	5	3	2	1	0	0
Gas	4	12	38	61	102	90
<i>of which from H<sub>2</sub></i>	0	0	0	0	10	90
Oil	2	2	2	1	0	0
Biomass (& renewable waste)	0	12	28	45	77	107
Geothermal	0	6	14	23	39	56
Hydrogen	0	0	0	0	6	31
<b>CHP by producer</b>						
Main activity producers	8	11	19	29	46	63
Autoproducers	31	56	93	130	185	220
<b>Total generation</b>	<b>1,219</b>	<b>1,696</b>	<b>2,060</b>	<b>2,624</b>	<b>4,485</b>	<b>6,581</b>
Fossil	969	1,240	1,118	899	639	0
Hard coal (& non-renewable waste)	231	396	302	135	9	0
Lignite	147	157	69	34	4	0
Gas	471	602	681	700	621	0
Oil	87	70	53	20	1	0
Diesel	32	15	13	11	4	0
Nuclear	45	40	35	30	12	0
Hydrogen	0	0	0	0	75	425
<i>of which renewable H<sub>2</sub></i>	0	0	0	0	64	425
<b>Renewables (w/o renewable hydrogen)</b>	<b>206</b>	<b>416</b>	<b>907</b>	<b>1,695</b>	<b>3,760</b>	<b>6,156</b>
Hydro	175	225	243	253	273	300
Wind	2	74	228	505	1,253	1,988
PV	1	46	149	376	862	1,338
Biomass (& renewable waste)	8	38	58	75	110	135
Geothermal	20	27	129	209	414	564
Solar thermal power plants	0	1	81	234	698	1,556
Ocean energy	0	0	5	20	110	220
Distribution losses	99	128	145	174	244	323
Own consumption electricity	54	64	70	73	67	45
Electricity for hydrogen production	0	0	17	127	836	2,136
Electricity for synfuel production	0	0	0	0	15	69
<b>Final energy consumption (electricity)</b>	<b>1,081</b>	<b>1,503</b>	<b>1,828</b>	<b>2,250</b>	<b>3,322</b>	<b>4,008</b>
Fluctuating RES (PV, Wind, Ocean)	3	120	382	901	2,226	3,546
Share of fluctuating RES	0%	7%	19%	34%	50%	54%
<b>RES share (domestic generation)</b>	<b>17%</b>	<b>25%</b>	<b>44%</b>	<b>65%</b>	<b>85%</b>	<b>100%</b>

Table 13.9.16 Other Asia: Final Energy Consumption Transport PJ/a

	2012	2020	2025	2030	2040	2050
<b>Road</b>	<b>5,471</b>	<b>6,650</b>	<b>6,747</b>	<b>6,676</b>	<b>6,080</b>	<b>4,078</b>
Fossil fuels	5,143	6,085	5,774	4,969	2,022	0
Biofuels	79	320	602	614	730	431
Synfuels	0	0	0	0	18	48
Natural gas	248	239	212	195	129	0
Hydrogen	0	0	41	323	1,322	1,750
Electricity	1	5	218	575	1,878	1,897
<b>Rail</b>	<b>65</b>	<b>83</b>	<b>157</b>	<b>237</b>	<b>408</b>	<b>559</b>
Fossil fuels	60	57	47	47	19	0
Biofuels	0	1	5	7	12	12
Synfuels	0	0	0	0	0	1
Electricity	15	25	106	187	377	546
<b>Navigation</b>	<b>177</b>	<b>200</b>	<b>209</b>	<b>235</b>	<b>213</b>	<b>221</b>
Fossil fuels	177	198	206	212	139	0
Biofuels	0	2	3	22	73	199
Synfuels	0	0	0	0	2	22
<b>Aviation</b>	<b>172</b>	<b>212</b>	<b>245</b>	<b>256</b>	<b>321</b>	<b>399</b>
Fossil fuels	172	211	243	233	209	0
Biofuels	0	1	2	23	110	359
Synfuels	0	0	0	0	3	40
<b>Total (incl. pipelines)</b>	<b>5,886</b>	<b>7,144</b>	<b>7,358</b>	<b>7,403</b>	<b>7,040</b>	<b>5,305</b>
Fossil fuels	5,543	6,551	6,270	5,456	2,388	0
Biofuels (incl. biogas)	79	324	612	667	925	1,000
Synfuels	0	0	0	0	23	112
Natural gas	248	239	212	195	129	0
Hydrogen	0	0	41	323	1,322	1,750
Electricity	15	30	323	762	2,254	2,443
<b>Total RES</b>	<b>82</b>	<b>332</b>	<b>673</b>	<b>1,368</b>	<b>3,992</b>	<b>5,305</b>
<b>RES share</b>	<b>1%</b>	<b>5%</b>	<b>9%</b>	<b>18%</b>	<b>57%</b>	<b>100%</b>

Table 13.9.17 Other Asia: Heat Supply PJ/a

	2012	2020	2025	2030	2040	2050
<b>District heating plants</b>	<b>0</b>	<b>1</b>	<b>2</b>	<b>2</b>	<b>2</b>	<b>2</b>
Fossil fuels	0	0	0	0	0	0
Biomass	0	1	1	1	1	1
Solar collectors	0	0	0	1	1	1
Geothermal	0	0	1	1	1	1
<b>Heat from CHP<sup>1</sup></b>	<b>105</b>	<b>248</b>	<b>481</b>	<b>728</b>	<b>1,193</b>	<b>1,773</b>
Fossil fuels	105	150	227	306	348	0
Biomass	0	45	130	216	431	775
Geothermal	0	52	124	205	345	482
Hydrogen	0	0	0	0	69	516
<b>Direct heating</b>	<b>10,247</b>	<b>11,785</b>	<b>12,361</b>	<b>12,895</b>	<b>14,084</b>	<b>14,076</b>
Fossil fuels	5,167	5,775	5,520	4,994	3,491	0
Biomass	4,215	4,692	4,625	4,168	3,226	2,578
Solar collectors	4	107	446	1,131	2,527	3,703
Geothermal	0	182	327	485	944	1,248
Heat pumps <sup>2</sup>	0	4	93	378	759	1,540
Electric direct heating	861	1,025	1,350	1,740	2,849	4,093
Hydrogen	0	0	0	0	290	914
<b>Total heat supply<sup>3</sup></b>	<b>10,352</b>	<b>12,033</b>	<b>12,844</b>	<b>13,625</b>	<b>15,280</b>	<b>15,851</b>
Fossil fuels	5,272	5,926	5,747	5,300	3,839	0
Biomass	4,215	4,738	4,756	4,386	3,658	3,353
Solar collectors	4	107	446	1,131	2,528	3,703
Geothermal	0	234	451	690	1,289	1,731
Heat pumps <sup>2</sup>	0	4	93	378	759	1,540
Electric direct heating	861	1,025	1,350	1,740	2,849	4,093
Hydrogen	0	0	0	0	358	1,431
<b>RES share (including RES electricity)</b>	<b>42%</b>	<b>44%</b>	<b>49%</b>	<b>57%</b>	<b>72%</b>	<b>100%</b>

<sup>1</sup> public CHP and CHP autoproduction / <sup>2</sup> heat from ambient energy and electricity use / <sup>3</sup> incl. process heat, cooking

Table 13.9.18: Other Asia: Installed capacity GW

	2012	2020	2025	2030	2040	2050
<b>Total generation</b>	<b>289</b>	<b>432</b>	<b>621</b>	<b>944</b>	<b>1,829</b>	<b>2,751</b>
<b>Fossil</b>	<b>221</b>	<b>266</b>	<b>262</b>	<b>238</b>	<b>253</b>	<b>0</b>
Hard coal (& non-renewable waste)	41	66	58	31	2	0
Lignite	26	27	14	7	1	0
Gas (w/o H <sub>2</sub> )	109	132	153	178	244	0
Oil	33	34	30	14	1	0
Diesel	12	7	7	4	5	0
Nuclear	6	5	5	4	2	0
Hydrogen (fuel cells, gas power plants, gas CHP)	0	0	0	0	29	301
<b>Renewables</b>	<b>62</b>	<b>161</b>	<b>355</b>	<b>702</b>	<b>1,547</b>	<b>2,450</b>
Hydro	52	75	82	86	83	102
Wind	1	33	92	201	488	769
<i>of which wind offshore</i>	0	1	26	61	128	192
PV	1	36	116	290	665	1,030
Biomass (& renewable waste)	5	11	15	17	27	34
Geothermal	3	5	23	36	69	93
Solar thermal power plants	0	0	25	61	150	311
Ocean energy	0	0	3	10	55	110
Fluctuating RES (PV, Wind, Ocean)	2	69	210	502	1,208	1,909
Share of fluctuating RES	1%	16%	34%	53%	66%	69%
<b>RES share (domestic generation)</b>	<b>21%</b>	<b>37%</b>	<b>57%</b>	<b>74%</b>	<b>85%</b>	<b>89%</b>

Table 13.9.19: Other Asia: Final energy demand PJ/a

	2012	2020	2025	2030	2040	2050
<b>Total (incl. non-energy use)</b>	<b>26,182</b>	<b>30,298</b>	<b>31,457</b>	<b>32,176</b>	<b>33,377</b>	<b>32,132</b>
<b>Total energy use</b>	<b>23,024</b>	<b>27,120</b>	<b>28,133</b>	<b>28,747</b>	<b>29,734</b>	<b>28,112</b>
<b>Transport</b>	<b>5,886</b>	<b>7,144</b>	<b>7,358</b>	<b>7,403</b>	<b>7,040</b>	<b>5,305</b>
Oil products	5,543	6,551	6,270	5,456	2,388	0
Natural gas	248	239	212	195	129	0
Biofuels	79	324	612	667	925	1,000
Synfuels	0	0	0	0	23	112
Electricity	15	30	323	762	2,254	2,443
<i>RES electricity</i>	3	7	142	492	1,921	2,443
Hydrogen	0	0	41	323	1,322	1,750
<b>RES share Transport</b>	<b>1%</b>	<b>5%</b>	<b>9%</b>	<b>18%</b>	<b>57%</b>	<b>100%</b>
<b>Industry</b>	<b>7,331</b>	<b>9,240</b>	<b>9,771</b>	<b>10,128</b>	<b>10,909</b>	<b>10,806</b>
Electricity	1,751	2,358	2,707	3,146	4,054	5,080
<i>RES electricity</i>	295	578	1,192	2,032	3,456	5,080
Public district heat	9	28	91	127	193	243
<i>RES district heat</i>	0	12	67	103	179	243
Hard coal & lignite	1,922	2,296	1,907	1,021	196	0
Oil products	1,167	1,094	841	700	479	0
Gas	1,433	1,960	2,277	2,615	2,389	0
Solar	0	61	261	692	1,415	2,228
Biomass	1,048	1,260	1,306	1,292	801	649
Geothermal	0	183	350	534	1,117	1,775
Hydrogen	0	0	0	0	264	821
<b>RES share Industry</b>	<b>18%</b>	<b>23%</b>	<b>33%</b>	<b>46%</b> </		

Table 13.9.22: Other Asia: Investments in electricity generation

REF	UNIT	2012-2020	2021-2030	2031-2040	2041-2050	2012-2050	UNIT	ANNUAL AVERAGE 2012-2050
Fossil (w/o CHP)	billion \$	150.6	205.6	301.3	331.7	989.2	billion \$/a	25.4
Nuclear	billion \$	14.3	8.3	0.0	0.3	22.9	billion \$/a	0.6
CHP (fossil + renewable)	billion \$	8.5	6.5	5.2	4.4	24.5	billion \$/a	0.6
Renewables (w/o CHP)	billion \$	132.5	169.3	188.1	246.1	736.0	billion \$/a	18.9
<b>Total</b>	<b>billion \$</b>	<b>305.9</b>	<b>389.7</b>	<b>494.7</b>	<b>582.4</b>	<b>1,772.7</b>	<b>billion \$/a</b>	<b>45.5</b>
Conventional (fossil & nuclear)	billion \$	173.4	220.4	306.5	336.4	1,036.6	billion \$/a	26.6
Renewables	billion \$	132.5	169.3	188.1	246.1	736.0	billion \$/a	18.9
Biomass	billion \$	12.2	16.9	22.5	30.2	81.8	billion \$/a	2.1
Hydro	billion \$	78.7	99.3	91.0	107.7	376.7	billion \$/a	9.7
Wind	billion \$	5.5	18.6	32.9	62.0	119.1	billion \$/a	3.1
PV	billion \$	11.0	12.2	16.6	18.3	57.9	billion \$/a	1.5
Geothermal	billion \$	25.1	21.7	24.6	27.1	96.4	billion \$/a	2.5
Solar thermal power plants	billion \$	0.0	0.6	0.7	0.7	2.1	billion \$/a	0.1
Ocean energy	billion \$	0.0	0.0	0.0	0.0	0.0	billion \$/a	0.0
<b>E[R]</b>								
Fossil (w/o CHP)	billion \$	104.9	56.3	91.1	96.1	348.3	billion \$/a	8.9
Nuclear	billion \$	5.3	0.6	0.8	0.0	6.6	billion \$/a	0.2
CHP (fossil + renewable)	billion \$	28.5	58.2	63.9	85.3	235.9	billion \$/a	6.0
Renewables (w/o CHP)	billion \$	226.6	1,078.5	1,482.1	1,652.6	4,439.8	billion \$/a	113.8
<b>Total</b>	<b>billion \$</b>	<b>365.3</b>	<b>1,193.6</b>	<b>1,637.8</b>	<b>1,833.9</b>	<b>5,030.7</b>	<b>billion \$/a</b>	<b>129.0</b>
Conventional (fossil & nuclear)	billion \$	119.0	71.7	104.6	113.2	408.6	billion \$/a	10.5
Renewables	billion \$	246.3	1,121.8	1,533.2	1,720.7	4,622.0	billion \$/a	118.5
Biomass	billion \$	16.3	21.4	38.6	46.3	122.6	billion \$/a	3.1
Hydro	billion \$	82.9	38.1	34.7	44.9	200.6	billion \$/a	5.1
Wind	billion \$	49.5	340.2	486.8	634.1	1,510.6	billion \$/a	38.7
PV	billion \$	62.5	261.0	343.0	363.6	1,030.1	billion \$/a	26.4
Geothermal	billion \$	34.8	221.2	197.3	201.0	654.4	billion \$/a	16.8
Solar thermal power plants	billion \$	0.3	190.7	269.1	295.3	755.4	billion \$/a	19.4
Ocean energy	billion \$	0.0	49.3	163.6	135.5	348.4	billion \$/a	8.9
<b>ADV E[R]</b>								
Fossil (w/o CHP)	billion \$	103.4	46.6	96.5	82.5	328.9	billion \$/a	8.4
Nuclear	billion \$	5.3	0.6	0.8	0.0	6.6	billion \$/a	0.2
CHP (fossil + renewable)	billion \$	28.5	58.2	64.0	82.8	233.4	billion \$/a	6.0
Renewables (w/o CHP)	billion \$	227.5	1,286.7	1,760.2	2,430.1	5,704.5	billion \$/a	146.3
<b>Total</b>	<b>billion \$</b>	<b>364.7</b>	<b>1,392.0</b>	<b>1,921.4</b>	<b>2,595.4</b>	<b>6,273.5</b>	<b>billion \$/a</b>	<b>160.9</b>
Conventional (fossil & nuclear)	billion \$	117.5	62.0	109.0	91.2	379.7	billion \$/a	9.7
Renewables	billion \$	247.2	1,330.0	1,812.4	2,504.2	5,893.8	billion \$/a	151.1
Biomass	billion \$	16.3	22.8	38.9	45.4	123.4	billion \$/a	3.2
Hydro	billion \$	82.9	40.7	34.7	42.0	200.3	billion \$/a	5.1
Wind	billion \$	49.5	356.5	558.2	778.9	1,743.0	billion \$/a	44.7
PV	billion \$	62.5	330.0	418.4	483.0	1,294.0	billion \$/a	33.2
Geothermal	billion \$	34.8	257.5	214.7	227.1	734.2	billion \$/a	18.8
Solar thermal power plants	billion \$	1.2	273.2	383.9	792.3	1,450.5	billion \$/a	37.2
Ocean energy	billion \$	0.0	49.3	163.6	135.5	348.4	billion \$/a	8.9

Table 13.9.23: Other Asia: Investments in renewable heat generation

REF	UNIT	2012-2020	2021-2030	2031-2040	2041-2050	2012-2050	UNIT	ANNUAL AVERAGE 2012-2050
Heat pumps	billion \$	0.0	0.0	0.0	0.0	0.0	billion \$/a	0.0
Deep geothermal	billion \$	0.0	0.0	0.0	0.0	0.0	billion \$/a	0.0
Solar thermal	billion \$	3.1	2.0	5.0	4.6	14.7	billion \$/a	0.4
Biomass	billion \$	52.6	35.3	24.8	14.1	126.9	billion \$/a	3.3
<b>Total</b>	<b>billion \$</b>	<b>55.7</b>	<b>37.3</b>	<b>29.8</b>	<b>18.8</b>	<b>141.6</b>	<b>billion \$/a</b>	<b>3.6</b>
<b>E[R]</b>								
Heat pumps	billion \$	0.9	108.8	91.0	253.2	453.8	billion \$/a	11.6
Deep geothermal	billion \$	40.4	62.0	116.2	100.9	319.5	billion \$/a	8.2
Solar thermal	billion \$	17.9	163.5	199.1	203.3	583.9	billion \$/a	15.0
Biomass	billion \$	122.0	15.7	0.0	0.1	137.7	billion \$/a	3.5
<b>Total</b>	<b>billion \$</b>	<b>181.1</b>	<b>350.0</b>	<b>406.4</b>	<b>557.4</b>	<b>1,494.9</b>	<b>billion \$/a</b>	<b>38.3</b>
<b>ADV E[R]</b>								
Heat pumps	billion \$	0.9	108.8	91.0	252.0	452.6	billion \$/a	11.6
Deep geothermal	billion \$	40.5	62.0	115.9	98.2	316.6	billion \$/a	8.1
Solar thermal	billion \$	17.9	163.5	198.6	203.6	585.6	billion \$/a	17.6
Biomass	billion \$	122.0	15.7	0.0	0.0	137.6	billion \$/a	3.5
<b>Total</b>	<b>billion \$</b>	<b>181.3</b>	<b>349.9</b>	<b>405.5</b>	<b>655.7</b>	<b>1,592.4</b>	<b>billion \$/a</b>	<b>40.8</b>

Table 13.9.24: Other Asia: Total employment in the energy sector THOUSAND JOBS

By sector	REFERENCE SCENARIO				ADV E[R] SCENARIO	
	2015	2020	2025	2030	2020	2025
Construction and installation	644	722	646	689	903	1,660
Manufacturing	297	341	312	344	376	845
Operations and maintenance	349	433	484	467	547	849
Fuel supply (domestic)	1,812	1,985	1,980	1,742	2,021	1,963
Coal and gas export	71.3	50.1	22.4	-	52.3	23.3
Solar and geothermal heat	36	36	32.5	25.2	363	927
<b>Total jobs (thousands)</b>	<b>3,209</b>	<b>3,567</b>	<b>3,476</b>	<b>3,267</b>	<b>4,262</b>	<b>6,208</b>
<b>By technology</b>						
Coal	783	870	816	946	126	90
Gas, oil & diesel	811	963	1,019	964	960	987
Nuclear	38	37	31	28.1	20.0	19.6
<b>Renewable</b>	<b>1,578</b>	<b>1,697</b>	<b>1,610</b>	<b>1,329</b>	<b>3,166</b>	<b>5,112</b>
Biomass	1,266	1,305	1,210	985	1,391	1,321
Hydro	203	249	249	199	160	118
Wind	13.3	32.7	43	56	412	823
PV	47	62	63	55.1	699	1,472
Geothermal power	12.4	11.4	9.9	7.9	78	92
Solar thermal power	0.2	0.8	1.0	1.0	37	299
Ocean	-	-	-	-	35.4	60
Solar - heat	36	36	32.5	25.2	243	773
Geothermal & heat pump	0.0	-	-	-	120	154
<b>Total jobs (thousands)</b>	<b>3,209</b>	<b>3,567</b>	<b>3,476</b>	<b>3,267</b>	<b>4,262</b>	<b>6,208</b>

# CHINA: REFERENCE SCENARIO

**Table 13.10.1 China: Electricity generation TWh/a**

	2012	2020	2025	2030	2040	2050
<b>Power plants</b>	<b>3,671</b>	<b>5,936</b>	<b>7,253</b>	<b>8,599</b>	<b>10,634</b>	<b>11,591</b>
Hard coal (& non-renewable waste)	2,526	3,543	4,344	5,174	6,572	6,954
Lignite	41	0	0	0	0	0
Gas	0	139	213	287	444	522
<i>of which from H<sub>2</sub></i>	0	0	0	0	0	0
Oil	8	5	4	4	4	3
Diesel	0	0	0	0	0	0
Nuclear	97	431	607	783	908	1,033
Biomass (& renewable waste)	34	174	220	267	321	375
Hydro	863	1,181	1,257	1,333	1,423	1,514
Wind	96	355	470	585	733	881
<i>of which wind offshore</i>	1	11	30	55	107	147
PV	6	106	133	160	200	247
Geothermal	0	1	2	3	8	17
Solar thermal power plants	0	1	2	4	20	42
Ocean energy	0	0	0	0	2	3
<b>Combined heat and power plants</b>	<b>1,353</b>	<b>1,607</b>	<b>1,704</b>	<b>1,772</b>	<b>1,862</b>	<b>1,899</b>
Hard coal (& non-renewable waste)	1,270	1,461	1,514	1,539	1,543	1,498
Lignite	0	0	0	0	0	0
Gas	83	147	190	233	319	401
<i>of which from H<sub>2</sub></i>	0	0	0	0	0	0
Oil	0	0	0	0	0	0
Biomass (& renewable waste)	0	0	0	0	0	0
Geothermal	0	0	0	0	0	0
Hydrogen	0	0	0	0	0	0
<b>CHP by producer</b>						
Main activity producers	0	0	0	0	0	0
Autoproducers	1,353	1,607	1,704	1,772	1,862	1,899
<b>Total generation</b>	<b>5,024</b>	<b>7,543</b>	<b>8,957</b>	<b>10,372</b>	<b>12,496</b>	<b>13,490</b>
Fossil	3,928	5,294	6,265	7,237	8,881	9,379
Hard coal (& non-renewable waste)	3,796	5,004	5,858	6,713	8,115	8,451
Lignite	0	0	0	0	0	0
Gas	124	285	403	520	763	924
Oil	8	5	4	4	4	3
Diesel	0	0	0	0	0	0
Nuclear	97	431	607	783	908	1,033
Hydrogen	0	0	0	0	0	0
<i>of which renewable H<sub>2</sub></i>	0	0	0	0	0	0
<b>Renewables (w/o renewable hydrogen)</b>	<b>999</b>	<b>1,818</b>	<b>2,085</b>	<b>2,352</b>	<b>2,707</b>	<b>3,079</b>
Hydro	863	1,181	1,257	1,333	1,423	1,514
Wind	96	355	470	585	733	881
PV	6	106	133	160	200	247
Biomass (& renewable waste)	34	174	221	267	321	375
Geothermal	0	1	2	3	8	17
Solar thermal power plants	0	1	2	4	20	42
Ocean energy	0	0	0	0	2	3
Distribution losses	295	453	542	630	763	828
Own consumption electricity	556	689	764	839	960	970
Electricity for hydrogen production	0	0	0	0	0	0
Electricity for synfuel production	0	0	0	0	0	0
<b>Final energy consumption (electricity)</b>	<b>4,172</b>	<b>6,402</b>	<b>7,652</b>	<b>8,903</b>	<b>10,775</b>	<b>11,694</b>
Fluctuating RES (PV, Wind, Ocean)	102	461	603	745	934	1,131
Share of fluctuating RES	2%	6%	7%	7%	7%	6%
<b>RES share (domestic generation)</b>	<b>20%</b>	<b>24%</b>	<b>23%</b>	<b>23%</b>	<b>22%</b>	<b>23%</b>

**Table 13.10.2 China: Final energy consumption in transport PJ/a**

	2012	2020	2025	2030	2040	2050
<b>Road</b>	<b>8,149</b>	<b>12,096</b>	<b>15,204</b>	<b>18,338</b>	<b>20,217</b>	<b>22,234</b>
Fossil fuels	7,656	11,124	14,028	16,946	18,238	19,772
Biofuels	51	135	255	375	579	696
Synfuels	0	0	0	0	0	0
Natural gas	443	819	839	859	1,044	1,257
Hydrogen	0	0	0	0	0	0
Electricity	0	19	82	158	356	510
<b>Rail</b>	<b>582</b>	<b>742</b>	<b>795</b>	<b>835</b>	<b>927</b>	<b>1,039</b>
Fossil fuels	395	395	395	395	395	395
Biofuels	0	0	0	0	0	0
Synfuels	0	0	0	0	0	0
Electricity	187	347	400	440	532	643
<b>Navigation</b>	<b>806</b>	<b>935</b>	<b>1,019</b>	<b>1,191</b>	<b>1,321</b>	<b>1,352</b>
Fossil fuels	806	935	1,019	1,191	1,321	1,352
Biofuels	0	0	0	0	0	0
Synfuels	0	0	0	0	0	0
<b>Aviation</b>	<b>513</b>	<b>879</b>	<b>1,082</b>	<b>1,184</b>	<b>1,260</b>	<b>1,279</b>
Fossil fuels	513	879	1,082	1,184	1,260	1,279
Biofuels	0	0	0	0	0	0
Synfuels	0	0	0	0	0	0
<b>Total (incl. pipelines)</b>	<b>10,058</b>	<b>14,663</b>	<b>18,112</b>	<b>21,561</b>	<b>23,742</b>	<b>25,923</b>
Fossil fuels	9,370	13,332	16,524	19,715	21,215	22,798
Biofuels (incl. biogas)	51	135	255	375	579	696
Synfuels	0	0	0	0	0	0
Natural gas	460	829	851	873	1,061	1,277
Hydrogen	0	0	0	0	0	0
Electricity	187	366	482	597	888	1,153
<b>Total RES</b>	<b>88</b>	<b>223</b>	<b>367</b>	<b>511</b>	<b>771</b>	<b>959</b>
<b>RES share</b>	<b>1%</b>	<b>2%</b>	<b>2%</b>	<b>2%</b>	<b>3%</b>	<b>4%</b>

**Table 13.10.3 China: Heat supply PJ/a**

	2012	2020	2025	2030	2040	2050
<b>District heating plants</b>	<b>3,413</b>	<b>4,366</b>	<b>4,547</b>	<b>4,730</b>	<b>4,656</b>	<b>4,501</b>
Fossil fuels	3,402	4,334	4,504	4,676	4,584	4,413
Biomass	12	32	43	54	72	87
Solar collectors	0	0	0	0	0	0
Geothermal	0	0	0	0	0	0
<b>Heat from CHP<sup>1</sup></b>	<b>3,077</b>	<b>3,852</b>	<b>4,225</b>	<b>4,552</b>	<b>5,153</b>	<b>5,698</b>
Fossil fuels	3,077	3,852	4,225	4,552	5,152	5,697
Biomass	0	0	0	0	1	1
Geothermal	0	0	0	0	0	0
Hydrogen	0	0	0	0	0	0
<b>Direct heating</b>	<b>32,424</b>	<b>37,248</b>	<b>38,366</b>	<b>39,492</b>	<b>39,606</b>	<b>39,400</b>
Fossil fuels	23,433	28,441	29,541	30,656	30,476	29,770
Biomass	6,209	5,383	5,087	4,777	4,466	4,293
Solar collectors	539	821	928	1,036	1,114	1,207
Geothermal	0	0	0	0	0	0
Heat pumps <sup>2</sup>	256	379	454	527	746	1,029
Electric direct heating	1,987	2,225	2,356	2,496	2,803	3,101
Hydrogen	0	0	0	0	0	0
<b>Total heat supply<sup>3</sup></b>	<b>38,915</b>	<b>45,467</b>	<b>47,138</b>	<b>48,773</b>	<b>49,414</b>	<b>49,599</b>
Fossil fuels	29,912	36,626	38,269	39,883	40,212	39,880
Biomass	6,221	5,416	5,131	4,832	4,539	4,382
Solar collectors	539	821	928	1,036	1,114	1,207
Geothermal	0	0	0	0	0	0
Heat pumps <sup>2</sup>	256	379	454	527	746	1,029
Electric direct heating	1,987	2,225	2,356	2,496	2,803	3,101
Hydrogen	0	0	0	0	0	0
<b>RES share (including RES electricity)</b>	<b>19%</b>	<b>16%</b>	<b>15%</b>	<b>15%</b>	<b>14%</b>	<b>15%</b>

<sup>1</sup> public CHP and CHP autoproduction / <sup>2</sup> heat from ambient energy and electricity use / <sup>3</sup> incl. process heat, cooking

**Table 13.10.4 China: Installed capacity GW**

	2012	2020	2025	2030	2040	2050
<b>Total generation</b>	<b>1,204</b>	<b>1,858</b>	<b>2,163</b>	<b>2,467</b>	<b>2,863</b>	<b>3,011</b>
<b>Fossil</b>	<b>854</b>	<b>1,145</b>	<b>1,330</b>	<b>1,515</b>	<b>1,779</b>	<b>1,785</b>
Hard coal (& non-renewable waste)	788	1,035	1,191	1,346	1,563	1,539
Lignite	0	0	0	0	0	0
Gas (w/o H <sub>2</sub> )	55	100	130	160	208	239
Oil	11	10	10	9	7	7
Diesel	0	0	0	0	0	0
Nuclear	14	58	82	106	122	139
Hydrogen (fuel cells, gas power plants, gas CHP)	0	0	0	0	0	0
<b>Renewables</b>	<b>337</b>	<b>655</b>	<b>751</b>	<b>847</b>	<b>962</b>	<b>1,087</b>
Hydro	249	390	383	406	434	461
Wind	75	183	227	269	312	362
<i>of which wind offshore</i>	0	4	10	18	33	44
PV	7	81	103	124	155	186
Biomass (& renewable waste)	6	30	38	46	55	64
Geothermal	0	0	0	0	1	2
Solar thermal power plants	0	0	1	1	5	10
Ocean energy	0	0	0	0	1	1
Fluctuating RES (PV, Wind, Ocean)	82	265	329	393	468	550
Share of fluctuating RES	7%	14%	15%	16%	16%	18%
<b>RES share (domestic generation)</b>	<b>28%</b>	<b>35%</b>	<b>35%</b>	<b>34%</b>	<b>34%</b>	<b>36%</b>

**Table 13.10.5 China: Final energy demand PJ/a**

	2012	2020	2025	2030	2040	2050
<b>Total (incl. non-energy use)</b>	<b>71,629</b>	<b>91,470</b>	<b>101,200</b>	<b>110,930</b>	<b>119,619</b>	<b>124,618</b>
<b>Total energy use</b>	<b>65,916</b>	<b>83,813</b>	<b>92,382</b>	<b>100,952</b>	<b>108,228</b>	<b>111,814</b>
<b>Transport</b>	<b>10,058</b>	<b>14,663</b>	<b>18,112</b>	<b>21,561</b>	<b>23,742</b>	<b>25,923</b>
Oil products	9,370	13,332	16,524	19,715	21,215	22,798
Natural gas	450	829	851	873	1,061	1,277
Biofuels	51	135	255	375	579	696
Synfuels	0	0	0	0	0	0
Electricity	187	366	482	597	888	1,153
RES electricity	37	88	112	135	192	263
Hydrogen	0	0	0	0	0	0
<b>RES share Transport</b>	<b>1%</b>	<b>2%</b>	<b>2%</b>	<b>2%</b>	<b>3%</b>	<b>4%</b>
<b>Industry</b>	<b>33,988</b>	<b>43,843</b>	<b>46,986</b>	<b>50,129</b>	<b>52,957</b>	<b>53,865</b>
Electricity	10,071	14,936	17,531	20,127	23,963	26,360
RES electricity	2,003	3,600	4,081	4,584	5,191	6,016
Public district heat	2,026	2,603	2,726	2,849	2,816	2,725
RES district heat	4	19	26	33	43	53
Hard coal & lignite	14,919	18,167	17,176	16,728	15,045	13,445
Oil products	2,452	2,688	2,729	2,769	2,531	2,272
Gas	4,512	5,367	6,540	7,170	7,762	7,725
Solar	0	9	18	26	84	194
Biomass	0	62	254			



**Table 13.10.8 China: Electricity generation TWh/a**

	2012	2020	2025	2030	2040	2050
<b>Power plants</b>	<b>3,671</b>	<b>5,655</b>	<b>6,107</b>	<b>6,519</b>	<b>7,765</b>	<b>8,455</b>
Hard coal (& non-renewable waste)	2,526	3,438	3,348	2,856	1,753	341
Lignite	0	0	0	0	0	0
Gas	41	87	91	100	92	86
<i>of which from H<sub>2</sub></i>	0	0	0	0	0	0
Oil	8	4	3	2	0	0
Diesel	0	0	0	0	0	0
Nuclear	97	250	230	200	146	0
Biomass (& renewable waste)	34	141	150	150	151	141
Hydro	863	1,181	1,220	1,250	1,310	1,370
Wind	96	390	679	1,108	2,128	2,940
<i>of which wind offshore</i>	1	20	82	177	467	700
PV	6	171	348	652	1,293	1,910
Geothermal	0	1	3	14	49	137
Solar thermal power plants	0	1	32	177	783	1,370
Ocean energy	0	0	2	10	60	160
<b>Combined heat and power plants</b>	<b>1,353</b>	<b>1,658</b>	<b>1,909</b>	<b>2,102</b>	<b>2,235</b>	<b>2,119</b>
Hard coal (& non-renewable waste)	1,270	1,428	1,346	1,153	545	122
Lignite	0	0	0	0	0	0
Gas	83	188	344	475	683	744
<i>of which from H<sub>2</sub></i>	0	0	0	0	7	27
Oil	0	0	0	0	0	0
Biomass (& renewable waste)	0	42	200	399	671	744
Geothermal	0	0	19	73	303	403
Hydrogen	0	0	0	2	34	106
<b>CHP by producer</b>						
Main activity producers	0	50	200	350	525	550
Autoproducers	1,353	1,608	1,709	1,752	1,710	1,569
<b>Total generation</b>	<b>5,024</b>	<b>7,313</b>	<b>8,016</b>	<b>8,621</b>	<b>10,001</b>	<b>10,574</b>
Fossil	3,928	5,146	5,132	4,586	3,065	1,265
Hard coal (& non-renewable waste)	3,796	4,866	4,694	4,009	2,298	462
Lignite	0	0	0	0	0	0
Gas	124	275	435	575	768	803
Oil	8	4	3	2	0	0
Diesel	0	0	0	0	0	0
Nuclear	97	250	230	200	146	0
Hydrogen	0	0	0	2	41	134
<i>of which renewable H<sub>2</sub></i>	0	0	0	1	28	117
<b>Renewables (w/o renewable hydrogen)</b>	<b>999</b>	<b>1,918</b>	<b>2,653</b>	<b>3,833</b>	<b>6,748</b>	<b>9,175</b>
Hydro	863	1,181	1,220	1,250	1,310	1,370
Wind	96	390	679	1,108	2,128	2,940
PV	6	171	348	652	1,293	1,910
Biomass (& renewable waste)	34	183	350	549	822	885
Geothermal	0	1	22	87	352	540
Solar thermal power plants	0	1	32	177	783	1,370
Ocean energy	0	0	2	10	60	160
Distribution losses	295	420	440	430	398	329
Own consumption electricity	556	654	687	654	547	272
Electricity for hydrogen production	0	0	5	56	523	1,245
Electricity for syngas production	0	0	0	0	0	0
<b>Final energy consumption (electricity)</b>	<b>4,172</b>	<b>6,240</b>	<b>6,884</b>	<b>7,482</b>	<b>8,534</b>	<b>8,730</b>
Fluctuating RES (PV, Wind, Ocean)	102	552	1,029	1,770	3,481	5,010
Share of fluctuating RES	2%	8%	13%	21%	35%	47%
<b>RES share (domestic generation)</b>	<b>20%</b>	<b>26%</b>	<b>33%</b>	<b>44%</b>	<b>68%</b>	<b>88%</b>

**Table 13.10.9 China: Final energy consumption in transport PJ/a**

	2012	2020	2025	2030	2040	2050
<b>Road</b>	<b>8,149</b>	<b>11,524</b>	<b>12,819</b>	<b>13,575</b>	<b>12,120</b>	<b>10,290</b>
Fossil fuels	7,656	10,622	11,693	11,473	7,062	2,945
Biofuels	51	142	243	386	515	442
Synfuels	0	0	0	0	0	0
Natural gas	443	724	731	709	672	457
Hydrogen	0	0	13	123	680	1,359
Electricity	0	36	238	884	3,191	5,088
<b>Rail</b>	<b>582</b>	<b>742</b>	<b>772</b>	<b>790</b>	<b>850</b>	<b>950</b>
Fossil fuels	395	385	332	242	108	35
Biofuels	0	0	18	58	42	15
Synfuels	0	0	0	0	0	0
Electricity	187	357	422	490	700	900
<b>Navigation</b>	<b>806</b>	<b>930</b>	<b>1,000</b>	<b>1,060</b>	<b>1,110</b>	<b>1,010</b>
Fossil fuels	806	930	950	965	888	707
Biofuels	0	0	50	95	222	303
Synfuels	0	0	0	0	0	0
<b>Aviation</b>	<b>513</b>	<b>870</b>	<b>975</b>	<b>1,000</b>	<b>880</b>	<b>800</b>
Fossil fuels	513	870	948	940	704	560
Biofuels	0	0	27	60	176	240
Synfuels	0	0	0	0	0	0
<b>Total (incl. pipelines)</b>	<b>10,058</b>	<b>14,075</b>	<b>15,575</b>	<b>16,435</b>	<b>14,970</b>	<b>13,060</b>
Fossil fuels	9,370	12,807	13,823	13,620	8,762	4,247
Biofuels (incl. biogas)	51	142	338	599	955	1,000
Synfuels	0	0	0	0	0	0
Natural gas	450	733	740	719	681	462
Hydrogen	0	0	13	123	680	1,359
Electricity	187	394	661	1,375	3,893	5,993
<b>Total RES</b>	<b>88</b>	<b>245</b>	<b>561</b>	<b>1,265</b>	<b>4,053</b>	<b>7,461</b>
<b>RES share</b>	<b>1%</b>	<b>2%</b>	<b>4%</b>	<b>8%</b>	<b>27%</b>	<b>57%</b>

**Table 13.10.10 China: Heat supply PJ/a**

	2012	2020	2025	2030	2040	2050
<b>District heating plants</b>	<b>3,413</b>	<b>3,922</b>	<b>3,916</b>	<b>3,755</b>	<b>3,334</b>	<b>2,806</b>
Fossil fuels	3,402	3,834	3,244	2,728	975	112
Biomass	12	68	280	427	581	505
Solar collectors	0	20	313	413	1,000	1,066
Geothermal	0	0	78	188	777	1,122
<b>Heat from CHP<sup>1</sup></b>	<b>3,077</b>	<b>4,655</b>	<b>5,793</b>	<b>7,028</b>	<b>9,356</b>	<b>10,043</b>
Fossil fuels	3,077	4,485	4,804	4,739	3,721	2,676
Biomass	0	170	821	1,641	2,766	3,055
Geothermal	0	0	168	635	2,602	3,447
Hydrogen	0	0	0	13	266	864
<b>Direct heating</b>	<b>32,424</b>	<b>35,575</b>	<b>34,993</b>	<b>32,742</b>	<b>25,769</b>	<b>21,272</b>
Fossil fuels	23,433	25,620	23,490	19,577	8,997	2,709
Biomass	6,209	5,766	5,887	5,380	4,601	4,865
Solar collectors	539	922	1,400	2,303	4,427	4,793
Geothermal	0	0	73	141	251	292
Heat pumps <sup>2</sup>	256	555	1,070	1,939	3,506	4,046
Electric direct heating	1,987	2,711	3,073	3,402	3,733	3,962
Hydrogen	0	0	0	0	254	605
<b>Total heat supply<sup>3</sup></b>	<b>38,915</b>	<b>44,152</b>	<b>44,702</b>	<b>43,525</b>	<b>38,459</b>	<b>34,121</b>
Fossil fuels	29,912	33,939	31,537	27,043	13,692	5,498
Biomass	6,221	6,005	6,969	7,448	7,949	8,425
Solar collectors	539	942	1,713	2,716	5,427	5,859
Geothermal	0	0	319	964	3,631	4,862
Heat pumps <sup>2</sup>	256	555	1,070	1,939	3,506	4,046
Electric direct heating	1,987	2,711	3,073	3,402	3,733	3,962
Hydrogen	0	0	0	13	520	1,469
<b>RES share (including RES electricity)</b>	<b>19%</b>	<b>19%</b>	<b>25%</b>	<b>34%</b>	<b>62%</b>	<b>82%</b>

<sup>1</sup> public CHP and CHP autoproduction / <sup>2</sup> heat from ambient energy and electricity use / <sup>3</sup> incl. process heat, cooking

**Table 13.10.10 China: Installed capacity GW**

	2012	2020	2025	2030	2040	2050
<b>Total generation</b>	<b>1,204</b>	<b>1,863</b>	<b>2,163</b>	<b>2,599</b>	<b>3,382</b>	<b>3,876</b>
<b>Fossil</b>	<b>854</b>	<b>1,111</b>	<b>1,101</b>	<b>1,049</b>	<b>786</b>	<b>433</b>
Hard coal (& non-renewable waste)	788	1,006	954	866	566	201
Lignite	0	0	0	0	0	0
Gas (w/o H <sub>2</sub> )	55	95	140	178	219	232
Oil	11	10	7	5	0	0
Diesel	0	0	0	0	0	0
Nuclear	14	34	31	27	20	0
Hydrogen (fuel cells, gas power plants, gas CHP)	7	0	0	0	11	36
<b>Renewables</b>	<b>337</b>	<b>718</b>	<b>1,031</b>	<b>1,523</b>	<b>2,565</b>	<b>3,407</b>
Hydro	249	300	372	381	399	415
Wind	75	195	320	498	884	1,181
<i>of which wind offshore</i>	7	27	56	144	209	209
PV	7	131	266	483	892	1,232
Biomass (& renewable waste)	6	31	60	106	164	194
Geothermal	0	0	3	13	63	81
Solar thermal power plants	0	0	9	39	154	249
Ocean energy	0	0	1	4	21	52
Fluctuating RES (PV, Wind, Ocean)	82	326	587	985	1,796	2,465
Share of fluctuating RES	7%	17%	27%	38%	53%	64%
<b>RES share (domestic generation)</b>	<b>28%</b>	<b>39%</b>	<b>48%</b>	<b>59%</b>	<b>76%</b>	<b>88%</b>

**Table 13.10.12 China: Final energy demand PJ/a**

	2012	2020	2025	2030	2040	2050
<b>Total (incl. non-energy use)</b>	<b>71,829</b>	<b>87,019</b>	<b>89,449</b>	<b>88,209</b>	<b>78,033</b>	<b>68,393</b>
<b>Total energy use</b>	<b>65,916</b>	<b>79,745</b>	<b>81,865</b>	<b>80,426</b>	<b>70,287</b>	<b>60,967</b>
<b>Transport</b>	<b>10,058</b>	<b>14,075</b>	<b>15,575</b>	<b>16,435</b>	<b>14,970</b>	<b>13,060</b>
Oil products	9,370	12,807	13,823	13,620	8,762	4,247
Natural gas	450	733	740	719	681	462
Biofuels	51	142	338	599	955	1,000
Synfuels	0	0	0	0	0	0
Electricity	187	394	661	1,375	3,893	5,993
RES electricity	37	103	219	611	2,638	5,267
Hydrogen	0	0	13	123	680	1,359
<b>RES share Transport</b>	<b>1%</b>	<b>2%</b>	<b>4%</b>	<b>9%</b>	<b>27%</b>	<b>57%</b>
<b>Industry</b>	<b>33,988</b>	<b>41,097</b>	<b>41,443</b>	<b>39,710</b>	<b>33,075</b>	<b>27,185</b>
Electricity	10,071	14,657	15,764	16,563	17,107	15,845
RES electricity	2,003	3,843	5,218	7,365	11,592	13,926
Public district heat	2,026	2,450	2,549	2,590	2,581	2,248
RES district heat	7	112	619	998	1,909	2,030
Hard coal & lignite	14,919	15,915	14,120	11,265	2,519	60
Oil products						

# CHINA: ADVANCED ENERGY [R]EVOLUTION SCENARIO

Table 13.10.15 China: Electricity generation TWh/a

	2012	2020	2025	2030	2040	2050
<b>Power plants</b>	<b>3,671</b>	<b>5,697</b>	<b>6,260</b>	<b>7,208</b>	<b>9,765</b>	<b>12,666</b>
Hard coal (& non-renewable waste)	2,526	3,436	3,319	2,770	792	0
Lignite	41	0	0	0	0	0
Gas	0	87	91	100	97	100
<i>of which from H<sub>2</sub></i>	0	0	0	2	14	100
Oil	8	4	3	2	0	0
Diesel	0	0	0	0	0	0
Nuclear	97	250	230	200	146	0
Biomass (& renewable waste)	34	141	150	150	151	150
Hydro	863	1,181	1,220	1,250	1,310	1,400
Wind	96	401	760	1,321	3,032	4,145
<i>of which wind offshore</i>	1	22	113	286	951	1,375
PV	6	191	421	826	1,752	2,520
Geothermal	0	2	9	52	220	432
Solar thermal power plants	0	2	52	522	2,185	3,729
Ocean energy	0	0	4	15	80	190
<b>Combined heat and power plants</b>	<b>1,353</b>	<b>1,658</b>	<b>1,909</b>	<b>2,102</b>	<b>2,235</b>	<b>2,119</b>
Hard coal (& non-renewable waste)	1,270	1,428	1,346	1,153	545	0
Lignite	0	0	0	0	0	0
Gas	83	188	344	475	683	729
<i>of which from H<sub>2</sub></i>	0	0	2	10	96	729
Oil	0	0	0	0	0	0
Biomass (& renewable waste)	0	42	200	399	671	775
Geothermal	0	0	19	73	303	479
Hydrogen	0	0	0	2	34	137
<b>CHP by producer</b>						
Main activity producers	0	50	200	350	525	550
Autoproducers	1,353	1,608	1,709	1,752	1,710	1,569
<b>Total generation</b>	<b>5,024</b>	<b>7,355</b>	<b>8,169</b>	<b>9,310</b>	<b>12,001</b>	<b>14,785</b>
Fossil	3,928	5,144	5,101	4,488	2,007	0
Hard coal (& non-renewable waste)	3,796	4,864	4,665	3,923	1,336	0
Lignite	0	0	0	0	0	0
Gas	124	275	433	564	671	0
Oil	8	4	3	2	0	0
Diesel	0	0	0	0	0	0
Nuclear	97	250	230	200	146	0
Hydrogen	0	0	2	13	143	966
<i>of which renewable H<sub>2</sub></i>	0	0	1	7	117	966
<b>Renewables (w/o renewable hydrogen)</b>	<b>999</b>	<b>1,961</b>	<b>2,835</b>	<b>4,608</b>	<b>9,705</b>	<b>13,820</b>
Hydro	863	1,181	1,220	1,250	1,310	1,400
Wind	96	401	760	1,321	3,032	4,145
PV	6	191	421	826	1,752	2,520
Biomass (& renewable waste)	34	183	350	549	822	925
Geothermal	0	2	28	125	523	911
Solar thermal power plants	0	2	52	522	2,185	3,729
Ocean energy	0	0	4	15	80	190
Distribution losses	295	420	440	430	502	437
Own consumption electricity	556	654	687	654	497	187
Electricity for hydrogen production	0	18	69	246	1,329	4,012
Electricity for synfuel production	0	5	0	215	614	950
<b>Final energy consumption (electricity)</b>	<b>4,172</b>	<b>6,258</b>	<b>6,973</b>	<b>7,765</b>	<b>9,061</b>	<b>9,202</b>
Fluctuating RES (PV, Wind, Ocean)	102	593	1,185	2,161	4,854	6,855
Share of fluctuating RES	2%	8%	15%	23%	41%	46%
<b>RES share (domestic generation)</b>	<b>20%</b>	<b>27%</b>	<b>35%</b>	<b>50%</b>	<b>82%</b>	<b>100%</b>

Table 13.10.16 China: Final Energy Consumption Transport PJ/a

	2012	2020	2025	2030	2040	2050
<b>Road</b>	<b>8,149</b>	<b>11,430</b>	<b>12,263</b>	<b>12,043</b>	<b>8,440</b>	<b>5,892</b>
Fossil fuels	7,656	10,475	10,882	9,572	2,859	0
Biofuels	51	142	251	404	631	426
Synfuels	0	7	0	207	595	608
Natural gas	443	713	625	466	112	0
Hydrogen	0	44	113	360	1,361	1,383
Electricity	0	55	392	1,241	3,477	4,083
<b>Rail</b>	<b>582</b>	<b>759</b>	<b>885</b>	<b>1,049</b>	<b>1,522</b>	<b>2,105</b>
Fossil fuels	395	354	283	191	54	0
Biofuels	0	0	15	22	19	10
Synfuels	0	0	0	11	17	15
Electricity	187	405	588	824	1,432	2,080
<b>Navigation</b>	<b>806</b>	<b>930</b>	<b>1,000</b>	<b>1,030</b>	<b>1,000</b>	<b>850</b>
Fossil fuels	806	930	990	891	650	0
Biofuels	0	0	10	92	180	350
Synfuels	0	0	0	47	170	500
<b>Aviation</b>	<b>513</b>	<b>861</b>	<b>946</b>	<b>930</b>	<b>695</b>	<b>520</b>
Fossil fuels	513	861	941	809	452	0
Biofuels	0	0	5	80	125	214
Synfuels	0	0	0	41	118	306
<b>Total (incl. pipelines)</b>	<b>10,058</b>	<b>13,996</b>	<b>15,103</b>	<b>15,269</b>	<b>12,262</b>	<b>9,985</b>
Fossil fuels	9,370	12,620	13,096	11,463	4,015	0
Biofuels (incl. biogas)	51	142	281	599	955	1,000
Synfuels	0	7	0	306	900	1,429
Natural gas	460	722	634	475	119	0
Hydrogen	0	44	113	360	1,361	1,383
Electricity	187	460	980	2,066	4,913	6,173
<b>Total RES</b>	<b>88</b>	<b>278</b>	<b>660</b>	<b>1,953</b>	<b>6,826</b>	<b>9,985</b>
<b>RES share</b>	<b>1%</b>	<b>2%</b>	<b>4%</b>	<b>13%</b>	<b>56%</b>	<b>100%</b>

Table 13.10.17 China: Heat Supply PJ/a

	2012	2020	2025	2030	2040	2050
<b>District heating plants</b>	<b>3,413</b>	<b>3,922</b>	<b>3,916</b>	<b>3,755</b>	<b>3,334</b>	<b>2,700</b>
Fossil fuels	3,402	3,834	3,244	2,728	975	0
Biomass	12	68	280	427	581	486
Solar collectors	0	20	313	413	1,000	1,026
Geothermal	0	0	78	188	777	1,188
<b>Heat from CHP<sup>1</sup></b>	<b>3,077</b>	<b>4,655</b>	<b>5,793</b>	<b>7,028</b>	<b>9,356</b>	<b>10,639</b>
Fossil fuels	3,077	4,485	4,799	4,711	3,450	0
Biomass	0	170	821	1,641	2,766	3,177
Geothermal	0	0	168	635	2,602	4,131
Hydrogen	0	0	5	41	537	3,331
<b>Direct heating</b>	<b>32,424</b>	<b>35,575</b>	<b>34,993</b>	<b>32,742</b>	<b>25,769</b>	<b>20,770</b>
Fossil fuels	23,433	25,620	23,453	19,423	8,204	0
Biomass	6,209	5,766	5,887	5,380	4,601	5,406
Solar collectors	539	922	1,400	2,303	4,427	4,685
Geothermal	0	0	73	141	251	292
Heat pumps <sup>2</sup>	256	555	1,070	1,939	3,632	4,313
Electric direct heating	1,987	2,711	3,073	3,402	3,733	4,107
Hydrogen	0	0	37	153	921	1,966
<b>Total heat supply<sup>3</sup></b>	<b>38,915</b>	<b>44,152</b>	<b>44,702</b>	<b>43,525</b>	<b>38,459</b>	<b>34,108</b>
Fossil fuels	29,912	33,939	31,495	26,862	12,629	0
Biomass	6,221	6,005	6,989	7,448	7,949	9,068
Solar collectors	539	942	1,713	2,716	5,427	5,711
Geothermal	0	0	319	964	3,631	5,611
Heat pumps <sup>2</sup>	256	555	1,070	1,939	3,632	4,313
Electric direct heating	1,987	2,711	3,073	3,402	3,733	4,107
Hydrogen	0	0	42	194	1,458	5,297
<b>RES share (including RES electricity)</b>	<b>19%</b>	<b>19%</b>	<b>25%</b>	<b>35%</b>	<b>65%</b>	<b>100%</b>

<sup>1</sup> public CHP and CHP autoproduction / <sup>2</sup> heat from ambient energy and electricity use / <sup>3</sup> incl. process heat, cooking

Table 13.10.18: China: Installed capacity GW

	2012	2020	2025	2030	2040	2050
<b>Total generation</b>	<b>1,204</b>	<b>1,889</b>	<b>2,254</b>	<b>2,876</b>	<b>4,107</b>	<b>5,074</b>
<b>Fossil</b>	<b>854</b>	<b>1,111</b>	<b>1,095</b>	<b>1,026</b>	<b>520</b>	<b>0</b>
Hard coal (& non-renewable waste)	788	1,006	948	847	313	0
Lignite	0	0	0	0	0	0
Gas (w/o H <sub>2</sub> )	55	95	140	175	206	0
Oil	11	10	7	5	0	0
Diesel	0	0	0	0	0	0
Nuclear	14	34	31	27	20	0
Hydrogen (fuel cells, gas power plants, gas CHP)	0	0	1	4	43	338
<b>Renewables</b>	<b>337</b>	<b>744</b>	<b>1,128</b>	<b>1,819</b>	<b>3,525</b>	<b>4,736</b>
Hydro	249	360	372	381	399	427
Wind	75	205	355	562	1,220	1,634
<i>of which wind offshore</i>	0	7	37	91	293	402
PV	7	146	321	612	1,208	1,626
Biomass (& renewable waste)	6	31	60	106	164	203
Geothermal	0	0	4	19	79	137
Solar thermal power plants	0	1	14	114	429	678
Ocean energy	0	0	1	5	27	62
Fluctuating RES (PV, Wind, Ocean)	82	352	678	1,199	2,455	3,291
Share of fluctuating RES	7%	19%	30%	42%	60%	65%
<b>RES share (domestic generation)</b>	<b>28%</b>	<b>39%</b>	<b>50%</b>	<b>63%</b>	<b>86%</b>	<b>93%</b>

Table 13.10.19: China: Final energy demand PJ/a

	2012	2020	2025	2030	2040	2050
<b>Total (incl. non-energy use)</b>	<b>71,629</b>	<b>86,940</b>	<b>88,977</b>	<b>87,280</b>	<b>75,923</b>	<b>65,692</b>
<b>Total energy use</b>	<b>65,916</b>	<b>79,666</b>	<b>81,393</b>	<b>79,497</b>	<b>68,177</b>	<b>58,266</b>
<b>Transport</b>	<b>10,058</b>	<b>13,996</b>	<b>15,103</b>	<b>15,269</b>	<b>12,262</b>	<b>9,985</b>
Oil products	9,370	12,620	13,096	11,463	4,015	0
Natural gas	450	722	634	475	119	0
Biofuels	51	142	281	599	955	1,000
Synfuels	0	7	0	306	900	1,429
Electricity	187	460	980	2,066	4,913	6,173
RES electricity	37	123	340	1,024	4,021	6,173
Hydrogen	0	44	113	360	1,361	1,383
<b>RES share Transport</b>	<b>1%</b>	<b>2%</b>	<b>4%</b>	<b>13%</b>	<b>56%</b>	<b>100%</b>
<b>Industry</b>	<b>33,988</b>	<b>41,097</b>	<b>41,443</b>	<b>39,783</b>	<b>33,283</b>	<b>26,926</b>
Electricity	10,071	14,657	15,764	16,663	17,395	16,442
RES electricity	2,003	3,907	5,473	8,280	14,236	16,442
Public district heat	2,026	2,450	2,549	2,580	2,581	2,154
RES district heat	7	112	619	1,000	1,928	2,154
Hard coal & lignite	14,919	15,915	14,120	11,265	2,519	

**Table 13.10.22: China: Investments in electricity generation**

REF	UNIT	2012-2020	2021-2030	2031-2040	2041-2050	2012-2050	UNIT	ANNUAL AVERAGE 2012-2050
Fossil (w/o CHP)	billion \$	327.4	578.5	579.6	688.4	2,153.9	billion \$/a	55.2
Nuclear	billion \$	134.4	172.0	69.5	81.1	457.0	billion \$/a	11.7
CHP (fossil + renewable)	billion \$	132.4	278.7	210.5	26.2	647.8	billion \$/a	16.6
Renewables (w/o CHP)	billion \$	651.9	401.4	553.1	470.3	2,076.7	billion \$/a	53.2
<b>Total</b>	<b>billion \$</b>	<b>1,246.1</b>	<b>1,430.6</b>	<b>1,412.8</b>	<b>1,246.0</b>	<b>5,335.5</b>	<b>billion \$/a</b>	<b>136.8</b>
Conventional (fossil & nuclear)	billion \$	594.1	1,029.2	859.6	775.7	3,258.6	billion \$/a	83.6
Renewables	billion \$	652.0	401.4	553.1	470.3	2,076.8	billion \$/a	53.3
Biomass	billion \$	40.1	30.8	54.1	43.7	168.7	billion \$/a	4.3
Hydro	billion \$	290.7	129.1	93.8	95.2	608.8	billion \$/a	15.6
Wind	billion \$	174.0	177.0	268.4	241.1	860.5	billion \$/a	22.1
PV	billion \$	145.5	58.3	113.5	58.7	375.9	billion \$/a	9.6
Geothermal	billion \$	0.7	2.7	4.2	7.4	14.9	billion \$/a	0.4
Solar thermal power plants	billion \$	1.0	3.5	17.3	23.0	44.9	billion \$/a	1.2
Ocean energy	billion \$	0.0	0.0	1.8	1.2	3.1	billion \$/a	0.1
<b>E[R]</b>								
Fossil (w/o CHP)	billion \$	293.7	25.4	12.1	209.6	540.8	billion \$/a	13.9
Nuclear	billion \$	59.0	0.0	0.0	0.0	59.0	billion \$/a	1.5
CHP (fossil + renewable)	billion \$	149.3	442.6	541.5	470.0	1,603.4	billion \$/a	41.1
Renewables (w/o CHP)	billion \$	750.6	1,293.0	2,095.6	2,181.7	6,320.9	billion \$/a	162.1
<b>Total</b>	<b>billion \$</b>	<b>1,252.6</b>	<b>1,761.0</b>	<b>2,649.3</b>	<b>2,861.3</b>	<b>8,524.1</b>	<b>billion \$/a</b>	<b>218.6</b>
Conventional (fossil & nuclear)	billion \$	486.8	228.8	151.1	272.2	1,139.0	billion \$/a	29.2
Renewables	billion \$	765.8	1,532.1	2,498.2	2,589.0	7,385.2	billion \$/a	189.4
Biomass	billion \$	46.3	157.1	169.7	263.9	637.0	billion \$/a	16.3
Hydro	billion \$	290.7	79.4	75.1	76.2	521.4	billion \$/a	13.4
Wind	billion \$	195.4	519.6	827.0	929.2	2,471.2	billion \$/a	63.4
PV	billion \$	231.4	462.4	550.5	543.6	1,787.9	billion \$/a	45.8
Geothermal	billion \$	0.7	123.1	307.6	248.4	679.8	billion \$/a	17.4
Solar thermal power plants	billion \$	1.1	173.5	508.1	450.4	1,133.1	billion \$/a	29.1
Ocean energy	billion \$	0.1	17.1	60.2	77.4	154.8	billion \$/a	4.0
<b>ADV E[R]</b>								
Fossil (w/o CHP)	billion \$	293.4	16.1	20.9	348.2	678.6	billion \$/a	17.4
Nuclear	billion \$	59.0	0.0	0.0	0.0	59.0	billion \$/a	1.5
CHP (fossil + renewable)	billion \$	149.3	442.6	541.5	555.5	1,688.8	billion \$/a	43.3
Renewables (w/o CHP)	billion \$	795.2	1,987.3	3,827.7	3,451.5	10,061.7	billion \$/a	258.0
<b>Total</b>	<b>billion \$</b>	<b>1,296.9</b>	<b>2,446.0</b>	<b>4,390.1</b>	<b>4,355.1</b>	<b>12,488.1</b>	<b>billion \$/a</b>	<b>320.2</b>
Conventional (fossil & nuclear)	billion \$	486.4	219.6	159.9	408.1	1,274.0	billion \$/a	32.7
Renewables	billion \$	810.5	2,226.4	4,230.2	3,947.0	11,214.2	billion \$/a	287.5
Biomass	billion \$	46.3	157.1	169.7	279.0	652.1	billion \$/a	16.7
Hydro	billion \$	290.7	79.4	75.1	94.6	539.9	billion \$/a	13.8
Wind	billion \$	210.5	676.9	1,338.7	1,228.9	3,455.0	billion \$/a	88.6
PV	billion \$	257.7	610.4	758.4	694.4	2,321.0	billion \$/a	59.5
Geothermal	billion \$	2.6	164.5	419.6	423.6	1,010.2	billion \$/a	25.9
Solar thermal power plants	billion \$	2.5	511.9	1,390.9	1,141.5	3,046.8	billion \$/a	78.1
Ocean energy	billion \$	0.1	26.2	77.9	85.0	189.2	billion \$/a	4.9

**Table 13.10.23: China: Investments in renewable heat generation**

REF	UNIT	2012-2020	2021-2030	2031-2040	2041-2050	2012-2050	UNIT	ANNUAL AVERAGE 2012-2050
Heat pumps	billion \$	77.7	80.7	111.4	121.0	390.7	billion \$/a	10.0
Deep geothermal	billion \$	0.0	0.0	0.0	0.0	0.0	billion \$/a	0.0
Solar thermal	billion \$	22.4	19.3	34.8	30.2	106.7	billion \$/a	2.7
Biomass	billion \$	5.8	22.5	20.1	37.9	86.2	billion \$/a	2.2
<b>Total</b>	<b>billion \$</b>	<b>105.9</b>	<b>122.4</b>	<b>166.3</b>	<b>189.0</b>	<b>583.6</b>	<b>billion \$/a</b>	<b>15.0</b>
<b>E[R]</b>								
Heat pumps	billion \$	111.2	357.7	416.9	414.4	1,300.1	billion \$/a	33.3
Deep geothermal	billion \$	0.0	68.1	364.8	314.0	746.9	billion \$/a	19.2
Solar thermal	billion \$	51.3	238.1	527.1	248.6	1,065.1	billion \$/a	27.3
Biomass	billion \$	23.5	50.5	58.8	69.4	202.3	billion \$/a	5.2
<b>Total</b>	<b>billion \$</b>	<b>186.1</b>	<b>714.3</b>	<b>1,367.7</b>	<b>1,046.4</b>	<b>3,314.4</b>	<b>billion \$/a</b>	<b>85.0</b>
<b>ADV E[R]</b>								
Heat pumps	billion \$	111.2	357.7	454.3	467.9	1,391.1	billion \$/a	35.7
Deep geothermal	billion \$	0.0	68.1	364.8	346.1	779.0	billion \$/a	20.0
Solar thermal	billion \$	51.3	238.1	527.1	144.1	960.6	billion \$/a	24.6
Biomass	billion \$	23.5	50.5	58.8	80.5	213.4	billion \$/a	5.5
<b>Total</b>	<b>billion \$</b>	<b>186.1</b>	<b>714.3</b>	<b>1,405.1</b>	<b>1,038.6</b>	<b>3,341.1</b>	<b>billion \$/a</b>	<b>85.7</b>

**Table 13.10.24: China: Total employment in the energy sector**

By sector	REFERENCE SCENARIO				ADV E[R] SCENARIO		
	2015	2020	2025	2030	2020	2025	2030
Construction and installation	1,544	1,328	1,197	776	931	1,499	1,441
Manufacturing	808	667	619	403	918	1,303	1,353
Operations and maintenance	720	998	1,075	1,039	1,059	1,373	1,653
Fuel supply (domestic)	4,167	3,730	3,219	2,773	3,616	2,929	2,314
Coal and gas export	-	-	-	-	-	-	-
Solar and geothermal heat	205	233	138	129	410	884	1,264
<b>Total jobs (thousands)</b>	<b>7,443</b>	<b>6,956</b>	<b>6,248</b>	<b>5,121</b>	<b>6,934</b>	<b>7,987</b>	<b>8,025</b>
<b>By technology</b>							
Coal	4,985	4,462	3,832	3,029	2,950	2,016	1,238
Gas, oil & diesel	316	501	632	747	549	695	852
Nuclear	178	253	223	170	53	46	32
<b>Renewable</b>	<b>1,964</b>	<b>1,739</b>	<b>1,560</b>	<b>1,175</b>	<b>3,382</b>	<b>5,230</b>	<b>5,903</b>
Biomass	709	738	694	549	860	1,256	1,265
Hydro	422	263	249	173	213	187	150
Wind	298	280	281	189	789	1,109	1,316
PV	326	221	195	126	1,054	1,496	1,309
Geothermal power	1.2	1.2	1.1	1.0	8	37	60
Solar thermal power	2.0	2.9	3.3	6.2	35	233	499
Ocean	0.01	0.17	0.30	0.75	12.3	28.3	40.1
Solar - heat	155	192	107	104	317	625	968
Geothermal & heat pump	50.2	40.2	31.2	25.8	93	258	296
<b>Total jobs (thousands)</b>	<b>7,443</b>	<b>6,956</b>	<b>6,248</b>	<b>5,121</b>	<b>6,934</b>	<b>7,987</b>	<b>8,025</b>

# OECD ASIA OCEANIA: REFERENCE SCENARIO

Table 13.11.1 OECD Asia Oceania: Electricity generation TWh/a

	2012	2020	2025	2030	2040	2050
<b>Power plants</b>	<b>1,780</b>	<b>1,944</b>	<b>2,031</b>	<b>2,122</b>	<b>2,258</b>	<b>2,281</b>
Hard coal (& non-renewable waste)	515	567	567	568	573	547
Lignite	144	145	145	145	140	130
Gas	570	406	434	466	487	472
<i>of which from H<sup>1</sup></i>	0	0	0	0	0	0
Oil	194	54	37	19	16	12
Diesel	7	7	7	7	7	6
Nuclear	166	446	471	496	517	517
Biomass (& renewable waste)	35	52	60	67	79	94
Hydro	116	133	137	141	149	149
Wind	14	46	69	91	135	168
<i>of which wind offshore</i>	0	1	2	4	11	19
PV	10	68	76	83	94	106
Geothermal	9	16	25	33	49	69
Solar thermal power plants	0	1	3	4	7	11
Ocean energy	0	2	2	3	6	10
<b>Combined heat and power plants</b>	<b>69</b>	<b>117</b>	<b>133</b>	<b>146</b>	<b>172</b>	<b>204</b>
Hard coal (& non-renewable waste)	7	15	17	19	23	26
Lignite	2	0	0	0	0	0
Gas	53	87	100	109	129	157
<i>of which from H<sup>1</sup></i>	0	0	0	0	0	0
Oil	5	9	9	10	8	7
Biomass (& renewable waste)	2	5	7	8	10	13
Geothermal	0	0	0	0	0	0
Hydrogen	0	1	1	1	1	1
<b>CHP by producer</b>						
Main activity producers	33	45	50	50	56	69
Autoproducers	36	72	83	96	116	135
<b>Total generation</b>	<b>1,849</b>	<b>2,061</b>	<b>2,164</b>	<b>2,268</b>	<b>2,430</b>	<b>2,485</b>
Fossil	1,497	1,289	1,316	1,342	1,383	1,357
Hard coal (& non-renewable waste)	521	581	584	587	597	573
Lignite	146	145	145	145	140	130
Gas	623	493	534	575	616	629
Oil	200	63	46	29	24	20
Diesel	7	7	7	7	7	6
Nuclear	166	446	471	496	517	517
Hydrogen	0	1	1	1	1	1
<i>of which renewable H<sup>1</sup></i>	0	0	0	0	0	0
<b>Renewables (w/o renewable hydrogen)</b>	<b>186</b>	<b>325</b>	<b>377</b>	<b>429</b>	<b>529</b>	<b>610</b>
Hydro	116	133	137	141	149	149
Wind	14	46	69	91	135	168
PV	10	68	76	83	94	106
Biomass (& renewable waste)	37	58	66	75	89	106
Geothermal	9	16	25	33	49	69
Solar thermal power plants	0	1	3	4	7	11
Ocean energy	0	2	2	3	6	10
Distribution losses	78	87	91	96	103	105
Own consumption electricity	119	133	137	142	148	148
Electricity for hydrogen production	0	3	3	4	4	4
Electricity for synfuel production	0	0	0	0	0	0
<b>Final energy consumption (electricity)</b>	<b>1,652</b>	<b>1,837</b>	<b>1,931</b>	<b>2,025</b>	<b>2,174</b>	<b>2,227</b>
Fluctuating RES (PV, Wind, Ocean)	23	116	147	177	234	275
Share of fluctuating RES	1%	6%	7%	8%	10%	11%
<b>RES share (domestic generation)</b>	<b>10%</b>	<b>16%</b>	<b>17%</b>	<b>19%</b>	<b>22%</b>	<b>25%</b>

Table 13.11.2 OECD Asia Oceania: Final energy consumption in transport PJ/a

	2012	2020	2025	2030	2040	2050
<b>Road</b>	<b>5,244</b>	<b>4,976</b>	<b>4,757</b>	<b>4,538</b>	<b>4,332</b>	<b>3,755</b>
Fossil fuels	5,167	4,858	4,610	4,361	4,076	3,412
Biofuels	27	28	29	29	32	28
Synfuels	0	0	0	0	0	0
Natural gas	51	73	88	103	148	203
Hydrogen	0	0	0	0	0	0
Electricity	0	17	31	45	76	113
<b>Rail</b>	<b>149</b>	<b>151</b>	<b>152</b>	<b>152</b>	<b>153</b>	<b>154</b>
Fossil fuels	59	60	60	60	60	60
Biofuels	0	0	0	0	0	0
Synfuels	0	0	0	0	0	0
Electricity	90	91	92	92	93	94
<b>Navigation</b>	<b>180</b>	<b>170</b>	<b>165</b>	<b>160</b>	<b>150</b>	<b>140</b>
Fossil fuels	180	170	165	160	150	140
Biofuels	0	0	0	0	0	0
Synfuels	0	0	0	0	0	0
<b>Aviation</b>	<b>292</b>	<b>308</b>	<b>317</b>	<b>325</b>	<b>342</b>	<b>338</b>
Fossil fuels	292	308	317	325	342	338
Biofuels	0	0	0	0	0	0
Synfuels	0	0	0	0	0	0
<b>Total (incl. pipelines)</b>	<b>5,881</b>	<b>5,621</b>	<b>5,405</b>	<b>5,190</b>	<b>4,992</b>	<b>4,403</b>
Fossil fuels	5,698	5,397	5,151	4,906	4,628	3,949
Biofuels (incl. biogas)	27	28	29	29	32	28
Synfuels	0	0	0	0	0	0
Natural gas	67	88	103	118	163	219
Hydrogen	0	0	0	0	0	0
Electricity	90	108	122	137	169	207
<b>Total RES</b>	<b>36</b>	<b>45</b>	<b>50</b>	<b>55</b>	<b>68</b>	<b>78</b>
<b>RES share</b>	<b>1%</b>	<b>1%</b>	<b>1%</b>	<b>1%</b>	<b>1%</b>	<b>2%</b>

Table 13.11.3 OECD Asia Oceania: Heat supply PJ/a

	2012	2020	2025	2030	2040	2050
<b>District heating plants</b>	<b>153</b>	<b>146</b>	<b>142</b>	<b>152</b>	<b>144</b>	<b>170</b>
Fossil fuels	140	119	116	124	118	139
Biomass	12	27	26	28	26	31
Solar collectors	0	0	0	0	0	0
Geothermal	0	0	0	0	0	0
<b>Heat from CHP<sup>1</sup></b>	<b>172</b>	<b>310</b>	<b>365</b>	<b>421</b>	<b>562</b>	<b>783</b>
Fossil fuels	165	286	336	384	506	689
Biomass	7	20	25	32	50	87
Geothermal	1	0	0	0	0	0
Hydrogen	0	4	5	5	6	6
<b>Direct heating</b>	<b>7,249</b>	<b>7,387</b>	<b>7,454</b>	<b>7,541</b>	<b>7,657</b>	<b>7,829</b>
Fossil fuels	6,234	6,237	6,254	6,290	6,282	6,263
Biomass	249	377	409	441	513	615
Solar collectors	27	46	64	81	131	199
Geothermal	0	0	0	0	0	0
Heat pumps <sup>2</sup>	30	31	33	34	36	38
Electric direct heating	708	695	695	695	695	714
Hydrogen	0	0	0	0	0	0
<b>Total heat supply<sup>3</sup></b>	<b>7,573</b>	<b>7,842</b>	<b>7,961</b>	<b>8,114</b>	<b>8,363</b>	<b>8,782</b>
Fossil fuels	6,540	6,643	6,706	6,799	6,906	7,091
Biomass	268	423	460	501	589	733
Solar collectors	27	46	64	81	131	199
Geothermal	1	0	0	0	0	0
Heat pumps <sup>2</sup>	30	31	33	34	36	38
Electric direct heating	708	695	695	695	695	714
Hydrogen	0	4	5	5	6	6
<b>RES share (including RES electricity)</b>	<b>5%</b>	<b>8%</b>	<b>9%</b>	<b>9%</b>	<b>11%</b>	<b>13%</b>

<sup>1</sup> public CHP and CHP autoproduction / <sup>2</sup> heat from ambient energy and electricity use / <sup>3</sup> incl. process heat, cooking

Table 13.11.4: OECD Asia Oceania: Installed capacity GW

	2012	2020	2025	2030	2040	2050
<b>Total generation</b>	<b>458</b>	<b>549</b>	<b>574</b>	<b>599</b>	<b>631</b>	<b>651</b>
<b>Fossil</b>	<b>297</b>	<b>323</b>	<b>331</b>	<b>339</b>	<b>338</b>	<b>333</b>
Hard coal (& non-renewable waste)	77	95	98	101	103	99
Lignite	21	24	24	25	24	22
Gas (w/o H <sup>1</sup> )	140	172	182	191	191	195
Oil	57	29	23	18	16	13
Diesel	2	3	4	4	4	4
Nuclear	68	67	66	65	68	68
Hydrogen (fuel cells, gas power plants, gas CHP)	0	0	0	0	0	0
<b>Renewables</b>	<b>93</b>	<b>159</b>	<b>177</b>	<b>194</b>	<b>225</b>	<b>250</b>
Hydro	69	71	72	74	76	76
Wind	6	16	24	31	44	51
<i>of which wind offshore</i>	0	0	1	1	3	5
PV	10	59	65	71	79	89
Biomass (& renewable waste)	6	10	11	12	15	18
Geothermal	1	2	4	5	7	10
Solar thermal power plants	0	0	1	1	2	2
Ocean energy	0	1	1	1	2	3
Fluctuating RES (PV, Wind, Ocean)	16	76	89	102	125	144
Share of fluctuating RES	4%	14%	16%	17%	20%	22%
<b>RES share (domestic generation)</b>	<b>20%</b>	<b>29%</b>	<b>31%</b>	<b>32%</b>	<b>36%</b>	<b>38%</b>

Table 13.11.5: OECD Asia Oceania: Final energy demand PJ/a

	2012	2020	2025	2030	2040	2050
<b>Total (incl. non-energy use)</b>	<b>23,756</b>	<b>24,178</b>	<b>24,225</b>	<b>24,272</b>	<b>24,143</b>	<b>23,393</b>
<b>Total energy use</b>	<b>20,108</b>	<b>20,583</b>	<b>20,680</b>	<b>20,798</b>	<b>21,007</b>	<b>20,596</b>
<b>Transport</b>	<b>5,881</b>	<b>5,621</b>	<b>5,405</b>	<b>5,190</b>	<b>4,992</b>	<b>4,403</b>
Oil products	5,698	5,397	5,151	4,906	4,628	3,949
Natural gas	67	88	103	118	163	219
Biofuels	27	28	29	29	32	28
Synfuels	0	0	0	0	0	0
Electricity	90	108	122	137	169	207
RES electricity	9	17	21	26	37	51
Hydrogen	0	0	0	0	0	0
<b>RES share Transport</b>	<b>1%</b>	<b>1%</b>	<b>1%</b>	<b>1%</b>	<b>1%</b>	<b>2%</b>
<b>Industry</b>	<b>6,564</b>	<b>6,960</b>	<b>6,991</b>	<b>7,022</b>	<b>6,888</b>	<b>6,755</b>
Electricity	2,235	2,520	2,606	2,691	2,779	2,869
RES electricity	225	398	454	509	605	704
Public district heat	89	85	86	86	78	70
RES district heat	3	11	11	11	10	9
Hard coal & lignite	1,161	1,521	1,437	1,352	1,172	960
Oil products	1,231	1,243	1,170	1,098	953	820
Gas	1,590	1,181	1,251	1,322	1,387	1,463
Solar	0	2	3	5	7	9
Biomass	252	401	432	462	505	557
Geothermal	7	7	7	7	7	7
Hydrogen	0	0	0	0	0	0
<b>RES share Industry</b>	<b>7%</b>	<b>12%</b>	<b>13%</b>	<b>14%</b>	<b>16%</b>	<b>19%</b>
<b>Other Sectors</b>	<b>7,663</b>	<b>8,002</b>	<b>8,284</b>	<b>8,586</b>	<b>9,127</b>	<b>9,439</b>
Electricity	3,624	3,987	4,224	4,462	4,877	4,940
RES electricity	364	629	736	844		

**Table 13.11.8 OECD Asia Oceania: Electricity generation TWh/a**

	2012	2020	2025	2030	2040	2050
<b>Power plants</b>	<b>1,780</b>	<b>1,883</b>	<b>1,897</b>	<b>1,959</b>	<b>2,077</b>	<b>1,943</b>
Hard coal (& non-renewable waste)	515	492	469	313	20	0
Lignite	144	110	92	50	5	0
Gas	570	462	403	390	337	69
of which from H <sub>2</sub>	0	0	0	0	17	28
Oil	194	120	72	29	13	5
Diesel	7	3	3	3	1	0
Nuclear	166	163	50	0	0	0
Biomass (& renewable waste)	35	74	71	73	60	37
Hydro	116	150	155	159	163	180
Wind	14	130	230	390	680	732
of which wind offshore	0	25	50	110	230	262
PV	10	98	210	310	440	469
Geothermal	9	56	72	99	125	146
Solar thermal power plants	0	16	40	100	140	175
Ocean energy	0	9	30	45	85	130
<b>Combined heat and power plants</b>	<b>69</b>	<b>100</b>	<b>140</b>	<b>166</b>	<b>208</b>	<b>245</b>
Hard coal (& non-renewable waste)	7	8	10	9	3	0
Lignite	2	5	3	0	0	0
Gas	53	68	87	90	73	36
of which from H <sub>2</sub>	0	0	0	0	0	5
Oil	5	4	3	4	2	0
Biomass (& renewable waste)	2	11	27	50	100	148
Geothermal	0	4	8	11	25	54
Hydrogen	0	1	1	2	4	8
<b>CHP by producer</b>						
Main activity producers	33	42	60	68	88	110
Autoproducers	36	58	80	98	120	135
<b>Total generation</b>	<b>1,849</b>	<b>1,983</b>	<b>2,036</b>	<b>2,125</b>	<b>2,285</b>	<b>2,188</b>
Fossil	1,497	1,272	1,143	887	436	78
Hard coal (& non-renewable waste)	521	500	480	322	23	0
Lignite	146	115	95	50	5	0
Gas	623	530	490	480	393	73
Oil	200	124	75	33	15	5
Diesel	7	3	3	3	1	0
Nuclear	166	163	50	0	0	0
Hydrogen	0	1	1	2	21	40
of which renewable H <sub>2</sub>	0	0	0	1	17	38
<b>Renewables (w/o renewable hydrogen)</b>	<b>186</b>	<b>548</b>	<b>843</b>	<b>1,237</b>	<b>1,828</b>	<b>2,070</b>
Hydro	116	150	155	159	163	180
Wind	14	130	230	390	680	732
PV	10	98	210	310	440	469
Biomass (& renewable waste)	37	85	98	123	160	184
Geothermal	9	60	80	110	160	200
Solar thermal power plants	0	16	40	100	140	175
Ocean energy	0	9	30	45	85	130
Distribution losses	78	83	85	87	90	90
Own consumption electricity	119	112	100	90	73	59
Electricity for hydrogen production	0	3	8	52	198	317
Electricity for synfuel production	0	0	0	0	0	0
<b>Final energy consumption (electricity)</b>	<b>1,652</b>	<b>1,786</b>	<b>1,843</b>	<b>1,896</b>	<b>1,924</b>	<b>1,722</b>
Fluctuating RES (PV, Wind, Ocean)	23	237	470	745	1,205	1,331
Share of fluctuating RES	1%	12%	23%	35%	53%	61%
<b>RES share (domestic generation)</b>	<b>10%</b>	<b>28%</b>	<b>41%</b>	<b>58%</b>	<b>81%</b>	<b>96%</b>

**Table 13.11.9 OECD Asia Oceania: Final energy consumption in transport PJ/a**

	2012	2020	2025	2030	2040	2050
<b>Road</b>	<b>5,244</b>	<b>5,037</b>	<b>4,450</b>	<b>3,784</b>	<b>2,771</b>	<b>2,150</b>
Fossil fuels	5,167	4,778	3,830	2,782	984	96
Biofuels	27	148	333	379	422	386
Synfuels	0	0	0	0	0	0
Natural gas	51	90	103	107	128	137
Hydrogen	0	1	12	114	360	486
Electricity	0	20	173	402	878	1,044
<b>Rail</b>	<b>149</b>	<b>144</b>	<b>135</b>	<b>132</b>	<b>131</b>	<b>138</b>
Fossil fuels	59	45	30	20	7	1
Biofuels	0	3	4	4	3	1
Synfuels	0	0	0	0	0	0
Electricity	90	96	102	108	121	136
<b>Navigation</b>	<b>180</b>	<b>173</b>	<b>162</b>	<b>151</b>	<b>130</b>	<b>110</b>
Fossil fuels	180	168	154	133	87	33
Biofuels	0	5	8	18	43	77
Synfuels	0	0	0	0	0	0
<b>Aviation</b>	<b>292</b>	<b>298</b>	<b>269</b>	<b>258</b>	<b>239</b>	<b>221</b>
Fossil fuels	292	298	250	213	179	88
Biofuels	0	0	19	45	60	132
Synfuels	0	0	0	0	0	0
<b>Total (incl. pipelines)</b>	<b>5,881</b>	<b>5,665</b>	<b>5,029</b>	<b>4,335</b>	<b>3,277</b>	<b>2,622</b>
Fossil fuels	5,698	5,289	4,264	3,148	1,257	219
Biofuels (incl. biogas)	27	156	364	447	527	596
Synfuels	0	0	0	0	0	0
Natural gas	67	103	114	117	133	138
Hydrogen	0	1	12	114	360	486
Electricity	90	117	275	510	1,000	1,182
<b>Total RES</b>	<b>36</b>	<b>188</b>	<b>483</b>	<b>810</b>	<b>1,625</b>	<b>2,204</b>
<b>RES share</b>	<b>1%</b>	<b>3%</b>	<b>10%</b>	<b>19%</b>	<b>50%</b>	<b>84%</b>

**Table 13.11.10 OECD Asia Oceania: Heat supply PJ/a**

	2012	2020	2025	2030	2040	2050
<b>District heating plants</b>	<b>153</b>	<b>151</b>	<b>154</b>	<b>192</b>	<b>193</b>	<b>178</b>
Fossil fuels	140	120	112	108	44	4
Biomass	12	31	39	57	91	117
Solar collectors	0	0	1	20	43	39
Geothermal	0	0	2	8	15	19
<b>Heat from CHP<sup>1</sup></b>	<b>172</b>	<b>292</b>	<b>473</b>	<b>611</b>	<b>986</b>	<b>1,564</b>
Fossil fuels	165	216	284	274	226	98
Biomass	7	42	125	238	539	985
Geothermal	1	31	60	88	195	418
Hydrogen	0	3	4	11	27	63
<b>Direct heating</b>	<b>7,249</b>	<b>6,968</b>	<b>6,536</b>	<b>6,197</b>	<b>5,316</b>	<b>4,076</b>
Fossil fuels	6,234	5,570	4,673	3,797	1,885	272
Biomass	249	570	678	763	913	911
Solar collectors	27	46	241	475	809	872
Geothermal	0	26	35	65	109	205
Heat pumps <sup>2</sup>	30	51	97	200	461	591
Electric direct heating	708	704	812	897	1,139	1,159
Hydrogen	0	0	0	0	0	67
<b>Total heat supply<sup>3</sup></b>	<b>7,573</b>	<b>7,410</b>	<b>7,163</b>	<b>7,000</b>	<b>6,496</b>	<b>5,818</b>
Fossil fuels	6,540	5,906	5,069	4,179	2,155	373
Biomass	268	643	842	1,059	1,543	2,012
Solar collectors	27	47	243	495	852	911
Geothermal	1	57	96	161	320	642
Heat pumps <sup>2</sup>	30	51	97	200	461	591
Electric direct heating	708	704	812	897	1,139	1,159
Hydrogen	0	3	4	11	27	131
<b>RES share (including RES electricity)</b>	<b>5%</b>	<b>14%</b>	<b>23%</b>	<b>35%</b>	<b>64%</b>	<b>93%</b>

<sup>1</sup> public CHP and CHP autoproduction / <sup>2</sup> heat from ambient energy and electricity use / <sup>3</sup> incl. process heat, cooking

**Table 13.11.10: OECD Asia Oceania: Installed capacity GW**

	2012	2020	2025	2030	2040	2050
<b>Total generation</b>	<b>458</b>	<b>585</b>	<b>708</b>	<b>823</b>	<b>948</b>	<b>975</b>
<b>Fossil</b>	<b>297</b>	<b>322</b>	<b>315</b>	<b>274</b>	<b>172</b>	<b>65</b>
Hard coal (& non-renewable waste)	77	62	80	64	5	0
Lignite	21	19	16	9	1	0
Gas (w/o H <sub>2</sub> )	140	164	179	180	156	62
Oil	57	56	38	20	10	3
Diesel	2	1	2	2	0	0
Nuclear	68	24	7	0	0	0
Hydrogen (fuel cells, gas power plants, gas CHP)	0	0	0	0	8	38
<b>Renewables</b>	<b>93</b>	<b>239</b>	<b>385</b>	<b>548</b>	<b>767</b>	<b>872</b>
Hydro	69	80	82	83	83	82
Wind	6	45	76	125	208	223
of which wind offshore	0	7	13	28	59	67
PV	10	84	180	264	370	384
Biomass (& renewable waste)	6	14	16	20	29	58
Geothermal	1	8	12	16	24	30
Solar thermal power plants	0	4	10	25	28	35
Ocean energy	0	3	10	14	26	40
Fluctuating RES (PV, Wind, Ocean)	16	132	265	403	604	657
Share of fluctuating RES	4%	23%	37%	49%	64%	67%
<b>RES share (domestic generation)</b>	<b>20%</b>	<b>41%</b>	<b>54%</b>	<b>67%</b>	<b>81%</b>	<b>89%</b>

**Table 13.11.12: OECD Asia Oceania: Final energy demand PJ/a**

	2012	2020	2025	2030	2040	2050
<b>Total (incl. non-energy use)</b>	<b>23,756</b>	<b>23,053</b>	<b>21,498</b>	<b>20,090</b>	<b>16,953</b>	<b>13,781</b>
<b>Total energy use</b>	<b>20,108</b>	<b>19,950</b>	<b>18,690</b>	<b>17,377</b>	<b>14,476</b>	<b>11,537</b>
<b>Transport</b>	<b>5,881</b>	<b>5,665</b>	<b>5,029</b>	<b>4,335</b>	<b>3,277</b>	<b>2,622</b>
Oil products	5,698	5,289	4,264	3,148	1,257	219
Natural gas	67	103	114	117	133	138
Biofuels	27	156	364	447	527	596
Synfuels	0	0	0	0	0	0
Electricity	90	117	275	510	1,000	1,182
RES electricity	9	32	114	297	807	1,139
Hydrogen	0	1	12	114	360	486
<b>RES share Transport</b>	<b>1%</b>	<b>3%</b>	<b>10%</b>	<b>19%</b>	<b>50%</b>	<b>84%</b>
<b>Industry</b>	<b>6,564</b>	<b>6,615</b>	<b>6,254</b>	<b>5,959</b>	<b>4,967</b>	<b>3,817</b>
Electricity	2,235	2,439	2,556	2,668	2,521	2,103
RES electricity	225	674	1,059	1,554	2,026	2,026
Public district heat	89	74	150	187	220	308
RES district heat	5	19	61	108	180	298
Hard coal & lignite	1,161	1,219	898	600	233	0
Oil products	1,231	1,193	953	748	340	44
Gas	1,590	1,015	874	758	524	189
Solar	0	11	69	170	232	247
Biomass	252	619	675	693	661	526
Geothermal	7	44	79	136	236	329
Hydrogen	0	0	0	0	0	71
<b>RES share Industry</b>	<b>7%</b>	<b>21%</b>	<b>31%</b>	<b>45%</b>	<b>67%</b>	<b>92%</b>
<b>Other Sectors</b>	<b>7,663</b>	<b>7,670</b>	<b>7</b>			

# OECD ASIA OCEANIA: ADVANCED ENERGY [R]EVOLUTION SCENARIO

Table 13.11.15 OECD Asia Oceania: Electricity generation TWh/a

	2012	2020	2025	2030	2040	2050
<b>Power plants</b>	<b>1,780</b>	<b>1,935</b>	<b>1,961</b>	<b>2,112</b>	<b>2,454</b>	<b>2,838</b>
Hard coal (& non-renewable waste)	515	494	408	241	8	0
Lignite	144	110	92	50	5	0
Gas	570	452	383	370	267	128
of which from H <sup>1</sup>	0	0	0	0	27	128
Oil	194	120	72	29	13	0
Diesel	7	3	3	3	1	0
Nuclear	166	163	50	0	0	0
Biomass (& renewable waste)	35	74	91	88	59	48
Hydro	116	150	155	159	163	180
Wind	14	160	280	450	820	1,020
of which wind offshore	0	35	70	150	320	380
PV	10	118	250	370	590	758
Geothermal	9	56	82	144	205	206
Solar thermal power plants	0	26	55	120	170	250
Ocean energy	0	9	40	90	155	248
<b>Combined heat and power plants</b>	<b>69</b>	<b>100</b>	<b>140</b>	<b>166</b>	<b>208</b>	<b>245</b>
Hard coal (& non-renewable waste)	7	8	10	9	2	0
Lignite	2	5	3	0	0	0
Gas	53	68	87	90	73	47
of which from H <sup>1</sup>	0	0	0	0	7	47
Oil	5	4	3	4	2	0
Biomass (& renewable waste)	2	11	27	50	101	136
Geothermal	0	4	8	11	25	54
Hydrogen	0	1	1	2	4	8
<b>CHP by producer</b>						
Main activity producers	33	42	60	68	88	110
Autoproducers	36	58	80	98	120	135
<b>Total generation</b>	<b>1,849</b>	<b>2,035</b>	<b>2,100</b>	<b>2,278</b>	<b>2,662</b>	<b>3,083</b>
Fossil	1,497	1,264	1,062	795	336	0
Hard coal (& non-renewable waste)	521	502	419	250	10	0
Lignite	146	115	95	50	5	0
Gas	623	520	470	460	306	0
Oil	200	124	75	33	15	0
Diesel	7	3	3	3	1	0
Nuclear	166	163	50	0	0	0
Hydrogen	0	1	1	2	38	183
of which renewable H <sup>1</sup>	0	0	0	1	33	183
<b>Renewables (w/o renewable hydrogen)</b>	<b>186</b>	<b>608</b>	<b>988</b>	<b>1,482</b>	<b>2,288</b>	<b>2,900</b>
Hydro	116	150	155	159	163	180
Wind	14	160	280	450	820	1,020
PV	10	118	250	370	590	758
Biomass (& renewable waste)	37	85	118	138	160	184
Geothermal	9	60	90	155	230	260
Solar thermal power plants	0	26	55	120	170	250
Ocean energy	0	9	40	90	155	248
Distribution losses	78	83	85	87	90	90
Own consumption electricity	119	112	100	90	73	59
Electricity for hydrogen production	0	7	25	92	335	823
Electricity for synfuel production	0	37	27	24	119	220
<b>Final energy consumption (electricity)</b>	<b>1,652</b>	<b>1,797</b>	<b>1,863</b>	<b>1,986</b>	<b>2,045</b>	<b>1,891</b>
Fluctuating RES (PV, Wind, Ocean)	23	287	570	910	1,565	2,026
Share of fluctuating RES	1%	14%	27%	40%	59%	66%
<b>RES share (domestic generation)</b>	<b>10%</b>	<b>30%</b>	<b>47%</b>	<b>65%</b>	<b>87%</b>	<b>100%</b>

Table 13.11.16 OECD Asia Oceania: Final Energy Consumption Transport PJ/a

	2012	2020	2025	2030	2040	2050
<b>Road</b>	<b>5,244</b>	<b>4,912</b>	<b>4,276</b>	<b>3,421</b>	<b>2,156</b>	<b>1,521</b>
Fossil fuels	5,167	4,623	3,600	2,325	590	0
Biofuels	27	146	322	319	178	51
Synfuels	0	47	34	28	126	129
Natural gas	51	84	88	75	24	0
Hydrogen	0	10	52	214	460	579
Electricity	0	44	214	487	903	890
<b>Rail</b>	<b>149</b>	<b>157</b>	<b>160</b>	<b>191</b>	<b>231</b>	<b>285</b>
Fossil fuels	59	41	25	15	4	0
Biofuels	0	2	3	3	1	0
Synfuels	0	1	0	0	1	1
Electricity	90	113	131	173	225	284
<b>Navigation</b>	<b>180</b>	<b>173</b>	<b>162</b>	<b>151</b>	<b>130</b>	<b>110</b>
Fossil fuels	180	166	153	131	84	0
Biofuels	0	5	9	18	27	31
Synfuels	0	2	1	2	19	79
<b>Aviation</b>	<b>292</b>	<b>295</b>	<b>265</b>	<b>245</b>	<b>203</b>	<b>172</b>
Fossil fuels	292	292	244	199	132	0
Biofuels	0	2	19	42	42	49
Synfuels	0	1	2	4	29	123
<b>Total (incl. pipelines)</b>	<b>5,881</b>	<b>5,597</b>	<b>4,910</b>	<b>4,046</b>	<b>2,852</b>	<b>2,221</b>
Fossil fuels	5,698	5,127	4,022	2,671	811	0
Biofuels (incl. biogas)	27	156	353	382	247	132
Synfuels	0	50	37	34	175	331
Natural gas	67	97	98	82	20	0
Hydrogen	0	10	52	214	460	579
Electricity	90	157	347	663	1,140	1,178
<b>Total RES</b>	<b>36</b>	<b>221</b>	<b>558</b>	<b>975</b>	<b>1,794</b>	<b>2,221</b>
<b>RES share</b>	<b>1%</b>	<b>4%</b>	<b>11%</b>	<b>24%</b>	<b>63%</b>	<b>100%</b>

Table 13.11.17 OECD Asia Oceania: Heat Supply PJ/a

	2012	2020	2025	2030	2040	2050
<b>District heating plants</b>	<b>153</b>	<b>141</b>	<b>154</b>	<b>192</b>	<b>193</b>	<b>202</b>
Fossil fuels	140	111	112	108	44	0
Biomass	12	29	39	57	91	137
Solar collectors	0	0	1	20	43	45
Geothermal	0	0	2	8	15	21
<b>Heat from CHP<sup>1</sup></b>	<b>172</b>	<b>302</b>	<b>473</b>	<b>611</b>	<b>986</b>	<b>1,523</b>
Fossil fuels	165	223	284	274	201	0
Biomass	7	43	125	238	543	911
Geothermal	1	32	60	88	195	418
Hydrogen	0	3	4	11	47	194
<b>Direct heating</b>	<b>7,249</b>	<b>6,968</b>	<b>6,536</b>	<b>6,197</b>	<b>5,316</b>	<b>4,093</b>
Fossil fuels	6,234	5,570	4,673	3,797	1,763	0
Biomass	249	570	678	763	913	711
Solar collectors	27	46	241	475	809	876
Geothermal	0	26	35	65	109	205
Heat pumps <sup>2</sup>	30	51	97	200	461	594
Electric direct heating	708	704	812	897	1,139	1,369
Hydrogen	0	0	0	0	122	338
<b>Total heat supply<sup>3</sup></b>	<b>7,573</b>	<b>7,410</b>	<b>7,163</b>	<b>7,000</b>	<b>6,496</b>	<b>5,818</b>
Fossil fuels	6,540	5,905	5,069	4,179	2,008	0
Biomass	268	642	842	1,059	1,548	1,758
Solar collectors	27	47	243	495	852	921
Geothermal	1	59	96	161	320	645
Heat pumps <sup>2</sup>	30	51	97	200	461	594
Electric direct heating	708	704	812	897	1,139	1,369
Hydrogen	0	3	4	11	169	533
<b>RES share (including RES electricity)</b>	<b>5%</b>	<b>14%</b>	<b>23%</b>	<b>36%</b>	<b>67%</b>	<b>100%</b>

<sup>1</sup> public CHP and CHP autoproduction / <sup>2</sup> heat from ambient energy and electricity use / <sup>3</sup> incl. process heat, cooking

Table 13.11.18: OECD Asia Oceania: Installed capacity GW

	2012	2020	2025	2030	2040	2050
<b>Total generation</b>	<b>458</b>	<b>612</b>	<b>752</b>	<b>897</b>	<b>1,120</b>	<b>1,376</b>
<b>Fossil</b>	<b>297</b>	<b>319</b>	<b>297</b>	<b>252</b>	<b>130</b>	<b>0</b>
Hard coal (& non-renewable waste)	77	82	70	50	2	0
Lignite	21	19	16	9	1	0
Gas (w/o H <sup>1</sup> )	140	161	171	172	116	0
Oil	57	56	38	20	10	0
Diesel	2	1	2	2	0	0
Nuclear	68	24	7	0	0	0
Hydrogen (fuel cells, gas power plants, gas CHP)	0	0	0	0	14	123
<b>Renewables</b>	<b>93</b>	<b>268</b>	<b>447</b>	<b>644</b>	<b>976</b>	<b>1,252</b>
Hydro	69	80	82	83	83	92
Wind	6	55	92	143	248	310
of which wind offshore	0	10	19	40	82	97
PV	10	101	214	315	496	637
Biomass (& renewable waste)	6	14	20	23	29	39
Geothermal	1	8	13	23	39	49
Solar thermal power plants	0	7	14	30	34	50
Ocean energy	0	3	13	28	48	76
Fluctuating RES (PV, Wind, Ocean)	16	159	318	486	791	1,023
Share of fluctuating RES	4%	26%	42%	54%	71%	74%
<b>RES share (domestic generation)</b>	<b>20%</b>	<b>44%</b>	<b>59%</b>	<b>72%</b>	<b>87%</b>	<b>91%</b>

Table 13.11.19: OECD Asia Oceania: Final energy demand PJ/a

	2012	2020	2025	2030	2040	2050
<b>Total (incl. non-energy use)</b>	<b>23,756</b>	<b>22,985</b>	<b>21,379</b>	<b>19,924</b>	<b>16,742</b>	<b>13,651</b>
<b>Total energy use</b>	<b>20,108</b>	<b>19,882</b>	<b>18,570</b>	<b>17,211</b>	<b>14,265</b>	<b>11,407</b>
<b>Transport</b>	<b>5,881</b>	<b>5,597</b>	<b>4,910</b>	<b>4,046</b>	<b>2,852</b>	<b>2,221</b>
Oil products	5,698	5,127	4,022	2,671	811	0
Natural gas	67	97	98	82	20	0
Biofuels	27	156	353	382	247	132
Synfuels	0	50	37	34	175	331
Electricity	90	157	347	663	1,140	1,178
RES electricity	9	47	163	432	994	1,178
Hydrogen	0	10	52	214	460	579
<b>RES share Transport</b>	<b>1%</b>	<b>4%</b>	<b>11%</b>	<b>24%</b>	<b>63%</b>	<b>100%</b>
<b>Industry</b>	<b>6,564</b>	<b>6,615</b>	<b>6,254</b>	<b>5,992</b>	<b>5,022</b>	<b>3,889</b>
Electricity	2,235	2,439	2,556	2,713	2,598	2,274
RES electricity	225	728	1,203	1,766	2,264	2,274
Public district heat	89	74	150	187	220	308
RES district heat	5	19	61	108	182	308
Hard coal & lignite	1,161	1,219	898	600	233	0
Oil products	1,231	1,193	953	740	332	0
Gas	1,590	1,015	874	753	461	0
Solar	0	11	69	170	232	247
Biomass	252	619	675	693	661	526
Geothermal	7	44	79	136	236	329
Hydrogen	0	0	0	0	50	206
<b>RES share Industry</b>	<b>7%</b>	<b>21%</b>	<b>33%</b>	<b>48%</b>	<b>72%</b>	<b>100%</b>
<b>Other Sectors</b>	<b>7,663</b>	<b>7,670</b>	<b>7,407</b>	<b>7,173</b>	<	

Table 13.11.22: OECD Asia Oceania: Investments in electricity generation

REF	UNIT	2012-2020	2021-2030	2031-2040	2041-2050	2012-2050	UNIT	ANNUAL AVERAGE 2012-2050
Fossil (w/o CHP)	billion \$	167.4	121.6	161.1	140.0	590.1	billion \$/a	15.1
Nuclear	billion \$	179.7	244.4	267.2	270.0	961.3	billion \$/a	24.6
CHP (fossil + renewable)	billion \$	101.4	45.1	66.0	32.7	245.1	billion \$/a	6.3
Renewables (w/o CHP)	billion \$	191.0	140.8	202.0	153.0	686.9	billion \$/a	17.6
<b>Total</b>	<b>billion \$</b>	<b>639.7</b>	<b>551.8</b>	<b>696.3</b>	<b>595.8</b>	<b>2,483.4</b>	<b>billion \$/a</b>	<b>63.7</b>
Conventional (fossil & nuclear)	billion \$	445.9	409.2	491.0	439.7	1,785.7	billion \$/a	45.8
Renewables	billion \$	193.8	142.6	205.2	156.1	697.7	billion \$/a	17.9
Biomass	billion \$	13.2	16.3	18.3	22.0	69.8	billion \$/a	1.8
Hydro	billion \$	35.0	45.2	45.2	37.1	162.6	billion \$/a	4.2
Wind	billion \$	20.5	33.4	43.5	44.6	142.1	billion \$/a	3.6
PV	billion \$	98.0	21.0	64.0	20.5	203.5	billion \$/a	5.2
Geothermal	billion \$	22.4	22.0	26.7	21.6	92.7	billion \$/a	2.4
Solar thermal power plants	billion \$	1.5	2.9	4.2	6.2	14.9	billion \$/a	0.4
Ocean energy	billion \$	3.1	1.7	3.3	4.1	12.1	billion \$/a	0.3
<b>E[R]</b>								
Fossil (w/o CHP)	billion \$	141.6	56.1	90.2	98.4	386.4	billion \$/a	9.9
Nuclear	billion \$	21.8	0.0	0.0	0.0	21.8	billion \$/a	0.6
CHP (fossil + renewable)	billion \$	82.4	70.2	69.9	160.2	382.7	billion \$/a	9.8
Renewables (w/o CHP)	billion \$	430.5	705.0	606.6	614.2	2,356.4	billion \$/a	60.4
<b>Total</b>	<b>billion \$</b>	<b>676.4</b>	<b>831.3</b>	<b>766.7</b>	<b>872.9</b>	<b>3,147.3</b>	<b>billion \$/a</b>	<b>80.7</b>
Conventional (fossil & nuclear)	billion \$	234.2	94.1	109.1	105.3	542.6	billion \$/a	13.9
Renewables	billion \$	442.2	737.2	657.6	767.6	2,604.6	billion \$/a	66.8
Biomass	billion \$	25.4	32.5	54.2	135.8	248.0	billion \$/a	6.4
Hydro	billion \$	62.8	47.2	37.2	64.1	211.4	billion \$/a	5.4
Wind	billion \$	86.3	186.5	258.1	193.2	724.2	billion \$/a	18.6
PV	billion \$	145.1	246.1	190.9	165.8	747.8	billion \$/a	19.2
Geothermal	billion \$	82.6	59.8	60.9	73.9	277.2	billion \$/a	7.1
Solar thermal power plants	billion \$	22.7	108.4	15.5	84.1	230.7	billion \$/a	5.9
Ocean energy	billion \$	17.3	56.7	40.8	50.7	165.4	billion \$/a	4.2
<b>ADV E[R]</b>								
Fossil (w/o CHP)	billion \$	139.8	33.8	77.4	141.0	391.8	billion \$/a	10.0
Nuclear	billion \$	21.8	0.0	0.0	0.0	21.8	billion \$/a	0.6
CHP (fossil + renewable)	billion \$	82.4	70.2	70.1	76.3	299.1	billion \$/a	7.7
Renewables (w/o CHP)	billion \$	495.1	912.0	856.9	996.5	3,260.5	billion \$/a	83.6
<b>Total</b>	<b>billion \$</b>	<b>739.1</b>	<b>1,016.0</b>	<b>1,004.4</b>	<b>1,213.8</b>	<b>3,973.3</b>	<b>billion \$/a</b>	<b>101.9</b>
Conventional (fossil & nuclear)	billion \$	232.3	71.7	95.9	146.9	546.8	billion \$/a	14.0
Renewables	billion \$	506.8	944.3	908.5	1,066.9	3,426.5	billion \$/a	87.9
Biomass	billion \$	25.4	38.8	49.8	67.4	181.3	billion \$/a	4.6
Hydro	billion \$	62.8	47.2	37.2	64.1	211.4	billion \$/a	5.4
Wind	billion \$	110.3	214.4	333.8	297.7	956.3	billion \$/a	24.5
PV	billion \$	171.2	291.3	285.7	288.1	1,036.3	billion \$/a	26.6
Geothermal	billion \$	82.6	107.6	109.8	102.5	402.5	billion \$/a	10.3
Solar thermal power plants	billion \$	37.1	120.8	27.6	147.8	333.3	billion \$/a	8.5
Ocean energy	billion \$	17.3	124.1	64.6	99.3	305.3	billion \$/a	7.8

Table 13.11.23: OECD Asia Oceania: Investments in renewable heat generation

REF	UNIT	2012-2020	2021-2030	2031-2040	2041-2050	2012-2050	UNIT	ANNUAL AVERAGE 2012-2050
Heat pumps	billion \$	4.5	4.2	1.9	1.3	11.8	billion \$/a	0.3
Deep geothermal	billion \$	0.0	0.0	0.0	0.0	0.0	billion \$/a	0.0
Solar thermal	billion \$	10.1	14.1	18.1	24.0	66.4	billion \$/a	1.7
Biomass	billion \$	24.9	18.2	18.5	12.5	74.1	billion \$/a	1.9
<b>Total</b>	<b>billion \$</b>	<b>39.5</b>	<b>36.5</b>	<b>38.5</b>	<b>37.7</b>	<b>152.2</b>	<b>billion \$/a</b>	<b>3.9</b>
<b>E[R]</b>								
Heat pumps	billion \$	8.2	39.1	72.9	69.3	189.5	billion \$/a	4.9
Deep geothermal	billion \$	6.1	8.1	15.5	27.2	56.9	billion \$/a	1.5
Solar thermal	billion \$	9.5	124.6	95.2	80.4	309.7	billion \$/a	7.9
Biomass	billion \$	44.2	44.6	47.7	24.3	160.7	billion \$/a	4.1
<b>Total</b>	<b>billion \$</b>	<b>68.0</b>	<b>216.3</b>	<b>231.3</b>	<b>201.2</b>	<b>716.7</b>	<b>billion \$/a</b>	<b>18.4</b>
<b>ADV E[R]</b>								
Heat pumps	billion \$	8.2	39.1	72.9	70.2	190.3	billion \$/a	4.9
Deep geothermal	billion \$	6.1	8.1	15.5	28.4	58.1	billion \$/a	1.5
Solar thermal	billion \$	9.5	124.6	95.2	83.3	312.7	billion \$/a	8.0
Biomass	billion \$	44.0	44.7	47.6	4.0	140.3	billion \$/a	3.6
<b>Total</b>	<b>billion \$</b>	<b>67.9</b>	<b>216.4</b>	<b>231.1</b>	<b>186.0</b>	<b>701.4</b>	<b>billion \$/a</b>	<b>18.0</b>

Table 13.11.24: OECD Asia Oceania: Total employment in the energy sector THOUSAND JOBS

By sector	REFERENCE SCENARIO				ADV E[R] SCENARIO		
	2015	2020	2025	2030	2020	2025	2030
Construction and installation	185	123	120	108	363	387	373
Manufacturing	35	15	15	10	95	113	108
Operations and maintenance	135	158	160	162	176	233	276
Fuel supply (domestic)	112	114	118	123	132	149	154
Coal and gas export	5.0	11.3	19.1	26.9	3.8	2.3	0.8
Solar and geothermal heat	6	7	9	9	13	108	145
<b>Total jobs (thousands)</b>	<b>478</b>	<b>428</b>	<b>442</b>	<b>438</b>	<b>782</b>	<b>992</b>	<b>1,056</b>
<b>By technology</b>							
Coal	90	81	88	88	52	41	24
Gas, oil & diesel	78	72	73	70	77	72	72
Nuclear	134	135	133	133	145	144	140
<b>Renewable</b>	<b>177</b>	<b>140</b>	<b>147</b>	<b>147</b>	<b>509</b>	<b>735</b>	<b>820</b>
Biomass	48	54	59	63	95	120	135
Hydro	17	17	18	18	21	19	17
Wind	9.7	13.0	15.2	16.7	68	109	130
PV	93.0	45.8	42.8	35.9	269	298	333
Geothermal power	1.0	2.1	2.1	2.0	8.1	12.9	10.3
Solar thermal power	0.4	0.7	0.9	1.1	15.1	32.2	26.7
Ocean	0.9	0.8	0.8	1.2	19	37	23.1
Solar - heat	6	6	9	8.6	6	99	119
Geothermal & heat pump	0.3	0.29	0.277	0.3	7	8	26
<b>Total jobs (thousands)</b>	<b>478</b>	<b>428</b>	<b>442</b>	<b>438</b>	<b>782</b>	<b>992</b>	<b>1,056</b>

### 13.5 2005 – 2015 – ONE DECADE OF ENERGY [R]EVOLUTION SCENARIOS

Greenpeace published the first Energy [R]evolution scenario in May 2005 for the EU-25 in conjunction with a 7-month long ship tour from Poland all the way down to Egypt. During the past 10 years, this work has developed significantly. The very first scenario was launched on board the ship with the support of former EREC Policy Director Oliver Schäfer, the start of a long-lasting fruitful Energy [R]evolution collaboration between Greenpeace International and EREC. The German Aerospace Center's Institute for Engineering Thermodynamics under Dr. Wolfram Krewitt's leadership has been the scientific institution behind all published energy revolutions since then as well. Between 2005 and 2009, these three very different stakeholders managed to put together over 30 scenarios for countries from all continents and published two editions of the Global Energy [R]evolution scenario, which became a well-respected, progressive, alternative energy blueprint. The work has been translated into over 15 different languages including Arabic, Chinese, French, German, Hebrew, Japanese, Russian, Spanish, Thai and Turkish.

The concept of an Energy [R]evolution scenario has been under constant development ever since. Today, we are able to calculate employment effects in parallel to the scenario development. The calculation program Mesap/PlaNet is from software firm seven2one, and lots of features were developed for this project. For the 2010 edition, we developed a standardised report tool, which provides us with a "ready to print" executive summary for each region and/or country we investigate. All regions also interact with each other, so the global scenario is set up like a cascade. These innovative developments serve for an ever improving quality, faster development times and more user-friendly outputs.

In the past years, a team of about 20 scientists from all regions across the world came together to review regional and/or country-specific scenarios and make sure that they properly reflect their region.

In some cases, these Energy [R]evolutions scenarios were the first ever published as long-term energy scenario for a country, such as the Turkish scenario published in 2009. Since the first Global Energy [R]evolution scenario published in January 2007, we have held side events at every single UNFCCC climate conference, countless energy conferences and panel debates. Over 200 presentations in more than 30 languages always had one message in common. "The Energy [R]evolution is possible; it is needed and pays off for future generations!"

Many high level meetings took place, for example on 15 July 2009, when Chilean President Michelle Bachelet attended our launch event for the Energy [R]evolution Chile.

The Energy [R]evolution work is a corner-stone of the Greenpeace climate and energy work worldwide. We would like to thank all involved stakeholders. Unfortunately, in October 2009, Dr Wolfram Krewitt of DLR passed away far

too early and left a huge gap for everybody. His energy and dedication helped to make the Energy [R]evolution project a true success story. Arthouros Zervos and Christine Lins of EREC were involved in this work from 2005 until 2013 when EREC stopped operation. Dr. Sven Teske of Greenpeace International developed the Energy [R]evolution scenario series and has headed this global project since the first development stage in November 2004.

Dr. Thomas Pregger, Dr. Tobias Naegler and Dr. Sonja Simon form the DLR core team responsible for modelling all Energy [R]evolution scenarios since 2009.

The well received layout of all Energy [R]evolution documents has been done – also from the very beginning – by Tania Dunster and Jens Christiansen from "onehemisphere" in Sweden with enormous passion, especially in the final phase when the report goes to print.

Over the past decade, all report texts have been written and/or edited by technical editors: Crispin Aubrey, Alexandra Dawe, Caroline Chisholm and – for the latest edition – Craig Morris made sure that the international science team published results in easy to read English.

With the third version of Energy [R]evolution 2010 report, published in June 2010 in Berlin, we reached out the scientific community to a much larger extent. The IPCC's Special Report Renewables (SRREN) chose the Energy [R]evolution as one of the four benchmark scenarios for climate mitigation energy scenarios (discussed in this edition in Chapter 5). The Energy [R]evolution was the most ambitious scenario: combining an uptake of renewable energy and energy efficiency, it put forwards the highest renewable energy share by 2050. However, this high share resulted in a very strict efficiency strategy, and other scenarios actually had more renewables in terms of exajoules by 2050. Following the publication of the SRREN in May 2011 in Abu Dhabi, the E[R] became a widely quoted energy scenario and is now part of many scientific debates and referenced in numerous scientific peer-reviewed literatures.

The fourth edition, Energy [R]evolution 2012, takes into account the significantly changed situation of the global energy sector that has occurred in just two years. In Japan, the 2011 Fukushima Nuclear disaster following the devastating tsunami in Japan, triggered a faster phase-out on nuclear power in several countries. A serious oil spill occurred at the Deepwater Horizon drilling platform in the Gulf of Mexico in 2010, highlighting the damage that can be done to eco-systems, and some countries are indicating new oil exploration in ever-more sensitive environments like the Arctic Circle. In the gas sector, there is an increase in shale gas projects, a particularly carbon-intensive way to obtain gas; it has required a more detailed analysis of the gas use projection in the Energy [R]evolution.

In March 2015, the Energy [R]evolution received worldwide recognition when a widely circulated report from the US



American Meister Consultants Group concluded that the rapid market growth of renewable power generation has been largely underestimated and report that “just about no one saw it coming. The world’s biggest energy agencies, financial institutions, and fossil fuel companies, for the most part, seriously underestimated just how fast the clean power sector could and would grow”. Meister identifies one group that got the market scenario closest to right, however, and it wasn’t the International Energy Agency or Goldman Sachs or the US Department of Energy (DOE).

“Over the past 15 years, a number of predictions—by the International Energy Agency, the US Energy Information Administration, and others—have been made about the future of renewable energy growth,” the Meister report noted. “Almost every one of these predictions has underestimated the scale of actual growth experienced by the wind and solar markets. Only the most aggressive growth projections, such as Greenpeace’s Energy [R]evolution scenarios, have been close to accurate.”

In the renewable energy sector, there has been a faster cost reduction in the photovoltaic and wind industries, creating earlier break-even points for these renewable energy investments. New and more detailed analysis of renewable energy potential is available, and new storage technologies are available, which could change the proportions of energy input types, for instance, reducing the need for bioenergy to make up the greenhouse gas reduction targets of the model. Several studies independently find that solar photovoltaic power generation will be the cheapest of all power generation technologies, with cost estimations of down to 3 to 5 cents per kilowatt-hour even in central Europe. In combination with new battery technology, PV has the potential to become truly disruptive for utilities.

During 2013 and 2014, when the costs for renewables dropped and for the first time outpaced investments in new fossil power generation, the 100% renewable energy movement grew. More and more communities, companies and civil society now demand a transition towards a fossil and nuclear free future by 2050 – only one generation from now.

This fifth edition of the Energy [R]evolution presents the first global energy pathway for a complete switch to renewables and what this means for future employment.

Taking the above into account, this edition of the Energy [R]evolution includes:

- Detailed investment pathways for power, heating and transport
- Detailed employment calculations for all sectors and the development of a social plan for oil, coal and gas workers
- Detailed market analysis of the current power plant market
- Detailed transport development pathway.

### 13.6 OVERVIEW OF THE ENERGY [R]EVOLUTION CAMPAIGN SINCE 2005

Greenpeace published the first Energy [R]evolution scenario in May 2005 for Europe.

A Global Energy [R]evolution scenario have been published in several scientific and peer-review journals like “Energy Policy”. See below a selection of milestones from the Energy [R]evolution work between 2005 and June 2010.

June 2005: First Energy [R]evolution scenario for EU 25 presented in Luxembourg for members of the EU’s Environmental Council

July – August 2005: National Energy [R]evolution scenarios for France, Poland and Hungary launched during an “Energy revolution” ship tour with a sailing vessel across Europe

January 2007: First Global Energy [R]evolution scenario published parallel in Brussels and Berlin

April 2007: Turkish translation from the Global scenario

July 2007: Futu[r]e Investment – an analysis of the needed global investment pathway for the energy revolution scenarios

November 2007: Energy [R]evolution for Indonesia in Jakarta / Indonesia

January 2008: Energy [R]evolution for New Zealand in Wellington / NZ

March 2008: Energy [R]evolution for Brazil in Rio de Janeiro / Brazil

April 2008: Energy [R]evolution for China in Beijing / China

June 2008: Energy [R]evolution for Japan in Aoi Mori & Tokyo/Japan

June 2008: Energy [R]evolution for Australia in Canberra / Australia

August 2008: Energy [R]evolution for the Philippines in Manila/Philippines

August 2008: Energy [R]evolution for the Mexico in Mexico City / Mexico

October 2008. Second edition of the Global Energy [R]evolution Report

December 2008: Energy [R]evolution for the EU-27 in Brussels / Belgium

December 2008. Launch of a concept for specific feed-in-tariff mechanism to implement the Global Energy [R]evolution Report in developing countries at a COP13 side event in Poznan / Poland

March 2009: Energy [R]evolution for the USA in Washington/USA

March 2009: Energy [R]evolution for India in Delhi / India

April 2009: Energy [R]evolution for Russia in Moscow / Russia

May 2009: Energy [R]evolution for Canada in Ottawa/Canada

June 2009: Energy [R]evolution for Greece in Athens/Greece

June 2009: Energy [R]evolution for Italy in Rome / Italy

July 2009: Energy [R]evolution for Chile in Santiago / Chile

July 2009: Energy [R]evolution for Argentina in Buenos Aires /Argentina

September 2009. Launch of the first detailed Job Analysis “Working for the Climate” – based on the global Energy [R]evolution report in Sydney/Australia

October 2009: Energy [R]evolution for South Africa in Johannesburg / SA

November 2009: Energy [R]evolution for Turkey in Istanbul / Turkey

November 2009: “Renewable 24/7” a detailed analysis for the needed grid infrastructure in order to implement the Energy [R]evolution for Europe with 90% renewable power in Berlin / Germany

April 2010: Energy [R]evolution for Sweden

May 2011: Energy [R]evolution South Africa

September 2011: Energy [R]evolution Japan

September 2011: Energy [R]evolution Argentina

November 2011: Energy [R]evolution Hungary

13 April 2012: Energy [R]evolution for South Korea

June 2012: 4th Edition of the Global Energy [R]evolution

June 2012: Energy [R]evolution for Czech Republic

October 2012: Energy [R]evolution for Israel

October 2012: Energy [R]evolution for EU 27

November 2012: Energy [R]evolution for Finland

November 2012: Energy [R]evolution for India

February 2013: Energy [R]evolution for New Zealand

April 2013: Energy [R]evolution for South Korea

August 2013: Energy [R]evolution for Brazil

September 2013: Energy [R]evolution for ASEAN region

November 2013: Energy [R]evolution for Switzerland

Nov 2013: Energy [R]evolution for Italy


February 2014: Energy [R]evolution for Mexico

April 2014: “powE[R] 2030” a detailed analysis for the needed grid infrastructure in order to implement the Energy [R]evolution for Europe with 75% renewable power by 2030

May 2014: Energy [R]evolution for USA

June 2015: Energy [R]evolution for Turkey





“There are no major economic or technical barriers to moving towards 100% renewable energy by 2050.”



**GREENPEACE**



UMWELTSTIFTUNG | **GREENPEACE**

**GWEC**  
GLOBAL WIND ENERGY COUNCIL

**SolarPower Europe**

Greenpeace is a global organisation that uses non-violent direct action to tackle the most crucial threats to our planet's biodiversity and environment. Greenpeace is a non-profit organisation, present in 40 countries across Europe, the Americas, Africa, Asia and the Pacific. It speaks for 2.8 million supporters worldwide, and inspires many millions more to take action every day. To maintain its independence, Greenpeace does not accept donations from governments or corporations but relies on contributions from individual supporters and foundation grants. Greenpeace has been campaigning against environmental degradation since 1971 when a small boat of volunteers and journalists sailed into Amchitka, an area west of Alaska, where the US Government was conducting underground nuclear tests. This tradition of 'bearing witness' in a non-violent manner continues today, and ships are an important part of all its campaign work.

Otto Heldringstraat 5, 1066 AZ Amsterdam, The Netherlands.  
t +31 20 718 2000 f +31 20 718 2002

Greenpeace e.V., Hongkongstrasse 10, 20457 Hamburg, Germany.  
info@greenpeace.de www.greenpeace.org

Vi.S.d.P.: Dr. Sven Teske

The Global Wind Energy Council (GWEC) is the voice of the global wind energy sector. GWEC works at highest international political level to create better policy environment for wind power. GWEC's mission is to ensure that wind power established itself as the answer to today's energy challenges, producing substantial environmental and economic benefits. GWEC is a member based organisation that represents the entire wind energy sector. The members of GWEC represent over 1,500 companies, organisations and institutions in more than 70 countries, including manufacturers, developers, component suppliers, research institutes, national wind and renewables associations, electricity providers, finance and insurance companies.

Rue d'Arlon 80, 1040 Brussels, Belgium  
t +32 2 213 1897 f +32 2 213 1890  
info@gwec.net www.gwec.net

**SolarPower Europe**, the new EPIA (European Photovoltaic Industry Association), is a member-led association representing organisations active along the whole value chain. Our aim is to shape the regulatory environment and enhance business opportunities for solar power in Europe.

Rue d'Arlon 69-71B, 1040 Brussels, Belgium  
t +32 2 709 55 20 f +32 2 725 32 50  
info@solarpowereurope.org www.solarpowereurope.org