

Global recycling markets: plastic waste

A story for one player – China



A report from the ISWA Task Force on Globalisation and
Waste Management

Author : Costas Velis



Prepared by: FUELogY on behalf of ISWA

Final formatting and typesetting:  D-WASTE™

Date: September 2014

Author: Dr Costas Velis – contact: c.velis@leeds.ac.uk

Cite as: Velis C.A. (2014). Global recycling markets - plastic waste: A story for one player – China. Report prepared by FUELogY and formatted by D-waste on behalf of International Solid Waste Association - Globalisation and Waste Management Task Force. ISWA, Vienna, September 2014.

Acknowledgements

We would like to thank Ms Sihui Zhou for relevant research conducted at Imperial College London as part of their MSc Thesis and Prof David Wilson and Prof Chris Cheeseman for co-supervising. We are grateful to CIWM and Defra UK for partly funding Ms Sihui Zhou under their Masters Support Programme, and for access to information. The ISWA Globalisation and Waste Management Task Force, ISWA STC and Board members and ISWA individual members and organisations who provided valuable feedback and proofread various earlier versions of this document. Ms Sophie Richard of WRAP, and staff at Valpak and Closed Loop Recycling who gave much valued support. Our appreciation also goes to Mr Ed Kosior, Honorary Prof at Brunel University and Mr Mike Jefferson of Verde Recycling Solutions of who took time out of their busy schedules to share their valuable experience and opinions. We are grateful to British Plastics Federation (BPF) for providing the opportunity to present an early version during REPLAST 2013. Our thanks to Ms Jiao Tang and Ms Rachael Williams of ISWA for their secretarial support. This report would not have been published if the D-Waste graphic designer, Mr Theodore Andreadakis, did not go the extra mile. The opinions expressed here are the author's alone.



ISWA

International Solid Waste Association

The International Solid Waste Association (ISWA) is a global, independent and non-profit making association, working in the public interest to promote and develop sustainable waste management. ISWA has members in more than 60 countries and is the only worldwide association promoting sustainable, comprehensive and professional waste management.

ISWA's objective is the worldwide exchange of information and experience on all aspects of waste management. The association promotes the adoption of acceptable systems of professional waste management through technological development and improvement of practices for the protection of human life, health and the environment as well as the conservation of materials and energy resources.

ISWA's vision is an Earth where no waste exists. Waste should be reused and reduced to a minimum, then collected, recycled and treated properly. Residual matter should be disposed of in a safely engineered way, ensuring a clean and healthy environment. All people on Earth should have the right to enjoy an environment with clean air, earth, seas and soils. To be able to achieve this, we need to work together.

For information about ISWA, visit our homepage at www.iswa.org

Executive Summary

The issue

Plastics are emblematic materials, transforming our everyday life for over 60 years, delivering unprecedented functionality. Plastics global production, mainly from fossil raw materials, has skyrocketed: from 1.5 million tonnes (Mt) in 1950 to 288 Mt in 2012. Sustainable consumption and production, and the circular economy, require minimising use of virgin materials and greenhouse gasses emissions, while delivering clean material cycles. To this end, globalised trade in waste plastics is a major option.

Production shift towards Asia

Recycling operations depend profoundly on production and consumption. A shift in plastics production from the West to Asia has occurred: 40% by weight of world production is now in Asia, with 20% each in Europe and North America - China is the largest individual country at 24%. The drivers were increasing local demand and lower costs - mainly labour, but also lower environmental and health and safety costs, due to the initial absence of regulations and/or their implementation in both manufacturing and reprocessing. This regional shift also drives the demand for used plastics.

Global recycling trade

The annual volume of globally traded waste plastics is around 15 Mt, less than 5% wt. of the new plastics production in 2012. Such a small percentage suggests that to-date international trade is a minor means to extract their resource value. Europe collectively is the major exporter, with the world's top 5 country exporters being Hong Kong SAR (re-exporting

imported material to China), USA, Japan, Germany and the UK. The top world importers are: China at \$6.1B and its SAR Hong Kong at \$1.65B, followed by the USA, the Netherlands

sumer plastic waste arisings. Europe depends entirely on China to absorb its exports (at least 87% of European exports end up in China). ASEAN countries (e.g. Vietnam, Malaysia and

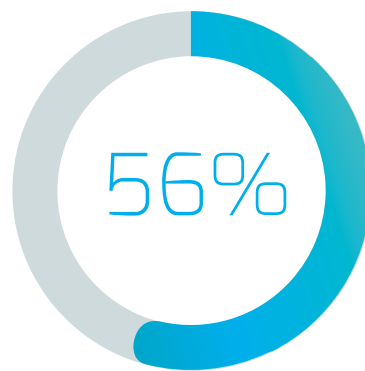

China is the leading importing country for waste plastics

China receives 56% (by weight) of the global imports of waste plastics

and Belgium. Plastic scrap flows from Western countries with established collection systems mainly to China, which dominates the international market, receiving around 56%

Indonesia) re-export reprocessed imports and domestically collected plastic scrap to China.

Plastics recycling in China

Between 2006 and 2012, plastic

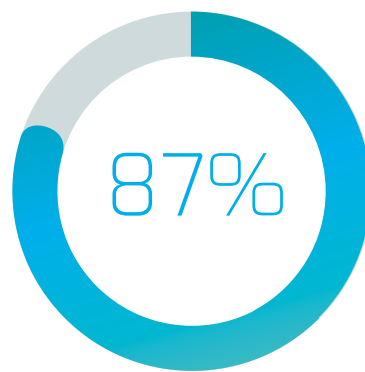

of EU-27 plastic waste exports (by weight) go to China

Most of plastic waste exports (by weight) from the EU-27 go to China and Hong Kong SAR

wt. of global imports. Europe (EU-27) collectively exports almost half of the plastics collected for recycling (3.4 Mt, worth of €1.7B), corresponding to 12% of the entire post-con-

scrap imports in China increased from 5.9 Mt to 8.9 Mt., whereas locally sourced plastics currently recovered (recycling and energy recovering) is almost double that amount.

There is no conclusive evidence on the fate of imported material when it reaches China. Indirect wider evi-

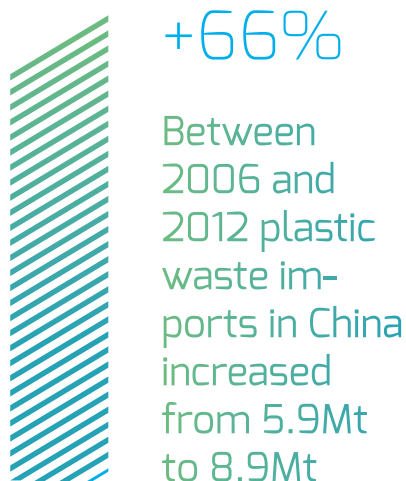

dence suggests that recent investments in modern centralized manufacturing and reprocessing facilities are still outweighed by thousands of small manufacturers/reprocessors

using low-tech equipment and pollution practices, often family-run, without any environmental protection controls. The domestic recyclates are perceived as of poor quality; hence good quality imported material is necessary for capital-intensive, better quality plastics manufacturing, while the inferior imports and domestic recycled plastics end up at the low-tech, uncontrolled plants and maybe also Energy from Waste (EfW) plants. The Chinese Government has been working to increase the quality of imported plastics and reduce the numbers of unregulated facilities: evidence can be seen in the recent Green Fence Operation (GFO) forcing a 'step change' in the quality of imported plastics by adopting a 'zero tolerance' approach to contamination level of imports and closing down unlicensed operators.

Market complexity and vulnerability
As with any globalised market, global

plastic scrap has an inevitably complex market, vulnerable to disruption, as seen when prices crashed for secondary raw materials during the 2008-9 financial crisis and the 2013 GFO. Key factors are: Oligopsony, especially for Europe, with China the main global importer; prohibitions relating to export / import of waste; susceptibility to virgin raw materials and fuel cost fluctuations; 'reverse haulage' logistics; high search and transaction costs; inconsistency of container loads sought by shipping lines; difficulty to quality control the exports; material quality information asymmetry between buyers and sellers – lack of transparency at the end of supply chain.

Does it matter that Western plastics recycling is so dependent on a single export market?

FREQUENT QUESTIONS

INSIGHTS

How much of the plastics collected for recycling in Europe are exported?

46% wt. of the overall quantity collected for recycling, which is 12% wt. of the entire plastic waste arisings in Europe. In contrast, Europe-27 exports only 1.2% of its primary plastics products to China.

How dependent is Europe on the Chinese market?

87% wt. of exports go to China directly or via the Hong Kong SAR. Overall dependency is even higher, if the exports to intermediate reprocessors (e.g. ASEAN countries) are added. Such a dependency may not be sustainable in the long-term.

Is the export market stable?

The global market experienced two recent 'shocks': the 2008-09 global financial crisis; and when the Chinese Green Fence Operation started in 2012. However, in both cases the market recovered / adapted relatively quickly.

Why does China import secondary plastics when it already generates its own domestic recyclates?

China needs affordable secondary plastics to meet the increased demand for plastic products. Part is supplied from the international market, and part from local recycling. But, the poor quality of much of the plastic products being manufactured in China means that the local recycled plastics is also of poor quality, and not suitable for use in the larger, modern factories manufacturing goods for export.

Will China continue to import plastics?

Recent projections (Pöyry) forecast an increased global demand for plastic (85 Mt by 2020) with subsequent increase of globally traded secondary plastics, fuelled by China's expected demand growth (predicted at 49 Mt in 2015). So quality secondary raw material imports will be needed, at least until the Chinese manufacturing base for the domestic market is upgraded, thus increasing the quality of domestic recyclates.

What about the quality of plastics for export to China?

The Chinese Government is working to clamp down on poor quality imports (lower contamination, increasing preference of single (or sorted) polymers) and eliminate unregulated facilities – so export of mixed plastics is likely to become more difficult.

Do the anticipated environmental benefits from recycling materialise in a globalised trade, dominated by imports in China?

The shift of the manufacturing base to Asia was driven by lower costs, which initially included lower costs due to an absence of environmental and health and safety controls. Plastics product manufacture and reprocessing in China was originally dominated by a large number of small, unregistered facilities with no rules for operation, no quality standards and no inspection. Investment is occurring in larger manufacturing plants which are subject to increasing quality and environmental controls; and the Government is working to eliminate unlicensed factories. But this change will take time, and currently, unless the exporter undertakes their own audit trail, the level of environmental control over imported plastics will remain uncertain.

Is dependence on a single importing country a risk?

Yes, for two reasons. First, China may in the medium- or long-term become self-sufficient in high-quality secondary plastics. Second, advanced recycling collection schemes in Europe/ N America etc. were created aspiring to achieve sustainable resource recovery. However, this is questionable when almost half of the collected plastics are exported to countries with lower environmental standards. Global plastic recycling markets in themselves may not lead to the required balance between environmental protection, clean material cycles and resource utilisation.

Should exporting countries be investing in local re-processing capacity for recycled plastics?

Yes, over-dependence on a single exporting country is risky. However, a balance is required. Quality, segregated polymers, e.g. clean PET from bottles, are increasingly sought-after commodities on the global market, with manufacturers in the US, Europe and China competing for a limited supply. So some export is normal - provided a 'level playing field' in terms of environmental standards can be assured.

What then should be done with mixed / unrecyclable plastics?

Segregate further and near the source to prepare a higher quality feedstock for recycling. Or develop innovative processes and invest in local capacity for mixed plastics recycling. Or consider waste to energy - high efficiency combined heat and power (CHP) plants can be a sustainable solution for the non-recyclable plastics (e.g. thermosets), particularly in countries that have high dependence on landfill disposal.

Sources of waste plastics imported in China in 2010

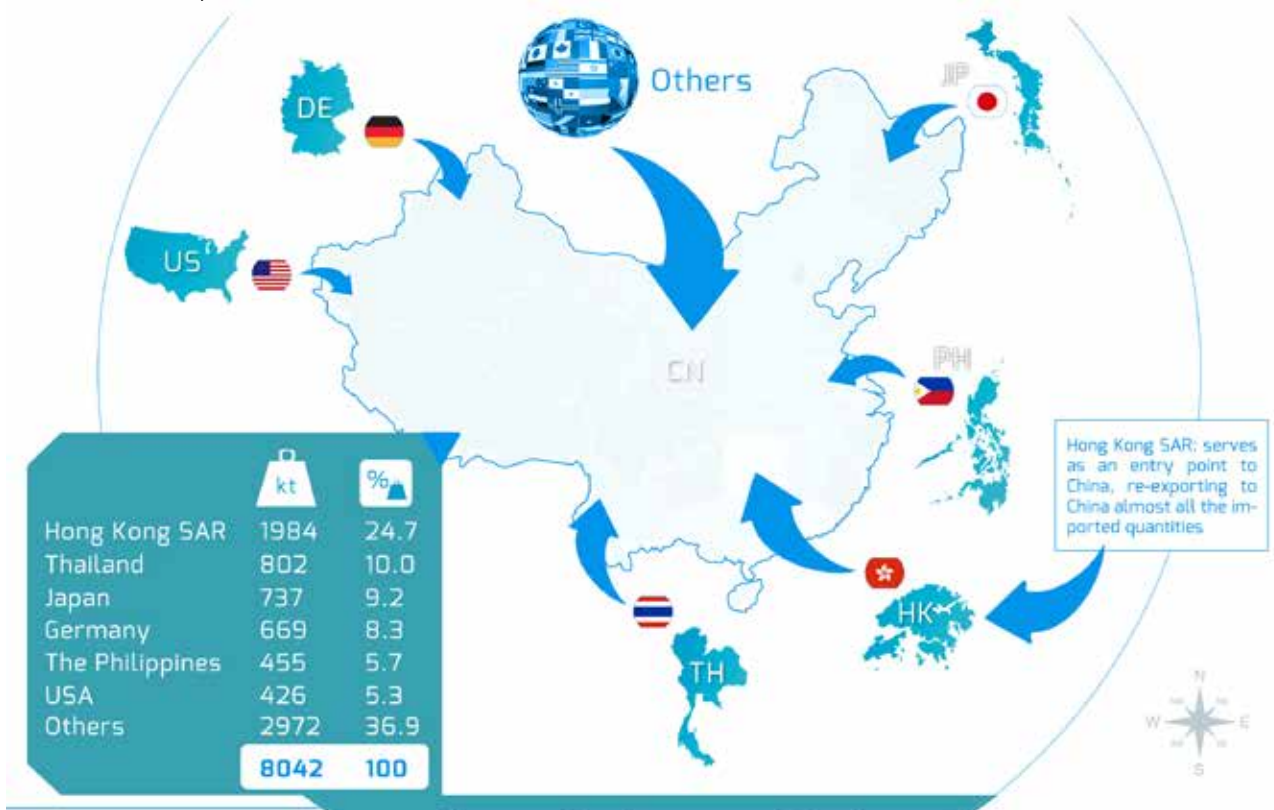

China is the dominant global player (importer)

Along with Hong Kong SAR this activity accounts for the 49% of the global financial activity in plastic scrap imports



EU-27 produces 25.2 M tonnes of post-consumer waste plastics

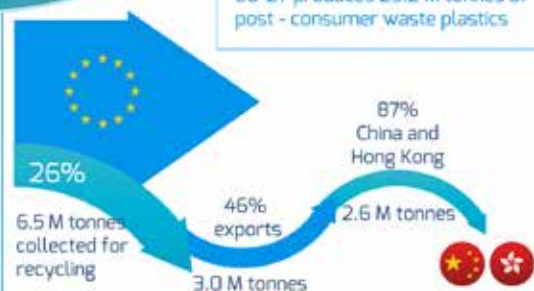

Europe (EU-27) exports 46% of all the post-consumer plastics collected for recycling; 87% wt. exported to China + Hong Kong SAR

Global demand for plastic scrap was recently predicted by Pöyry to reach 85Mt by 2020, fueled also by continued growth in China

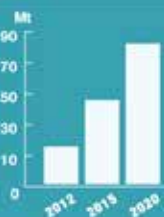

2006 2012

Between 2006 and 2012 plastic waste imports in China increased from 5.9Mt to 8.9Mt

Copyright: ISWA Background research: Fuelogy Infographic: D-Waste



Table of contents

Executive Summary.....	4
1. Background: Globalisation and waste management.....	14
2. Introduction, aim and scope.....	15
3. Plastic waste trade and flows: key facts and factors of a global market.....	17
3.1 Recycling and recovery of waste plastics: comparative EU data.....	17
3.2 A specific example: the UK case.....	18
3.3 The globalised plastic waste trade.....	20
3.4 Key market factors.....	21
3.5 Waste plastics markets vulnerability and volatility.....	22
4. Main trans-boundary flows of plastic waste (imports–exports).....	24
4.1 The big picture.....	24
4.2 China.....	25
4.3 Europe (EU-27).....	27
4.4 Hong Kong: China Special Administrative Area (SAR).....	28
4.5 Japan.....	29
4.6 USA.....	30
4.7 South-East Asia (ASEAN).....	31
5. Exports of different polymer types to China and Hong Kong.....	32
5.1 UK.....	32
5.2 Japan.....	33

5.3 USA.....	34
6. What happens within China?.....	35
6.1 China: Production and demand for plastics.....	35
6.2 Domestic generation of waste plastics.....	38
6.3 Imports of plastic waste.....	39
6.4. Estimated Use of Waste Plastics within China.....	40
7. Crisis time: the Chinese Green Fence Operation.....	45
7.1 Chinese administration imposes stricter enforcement of waste imports rules.....	45
7.2 Green Fence Operation impacts on the global waste plastics recycling market.....	47
7.3 Possible long-term responses to the Green Fence Operation crisis?.....	49
8.Environmental and health considerations.....	50
8.1 General concerns for plastics recycling under poor environmental control capacity and law enforcement.....	50
8.2 A path of least resistance?.....	51
9. Challenges for trans-boundary trade.....	55
10. Future outlook - trends - questions.....	56
11. Key facts summary.....	59
References.....	61



List of Tables

Table 1. World value of waste plastics trading (exports – imports) according to the UN Comtrade data for 2012.....	24
Table 2. Financial value and weight of EU-27 waste plastics trading (exports – imports) according to the UN Comtrade data for 2012	27
Table 3. Chinese plastics production and types of plastic products.....	36
Table 4. Sources of waste plastics imported to China in 2010	39
Table 5. Major applications of recycled plastics in China.....	43

List of Figures

Figure 1. Recovery rate of post-consumer plastic waste by country 2012.....	17
Figure 2. Material flow diagram for processing of plastics in the UK, 2009; quantities in million tonnes (Mt).....	18
Figure 3. Global map of export transactions in waste plastic in 2011.....	20
Figure 4. Production index of primary plastics.....	22
Figure 5. US waste plastics exports: The abrupt drop in 2008 coincides with the financial crisis and the drop in the production and prices of the primary plastics.....	23
Figure 6. Prices of reprocessed waste plastics in the UK market, for various grades: the collapse in prices corresponds to the financial crisis which has resulted in fall in the production index of primary plastics.....	23
Figure 7. Top importers and exporters of plastic waste worldwide, based on financial transactions.....	24
Figure 8. Global map of import transactions in waste plastic in 2011.....	25
Figure 9. Top importers of plastic waste to China, based on financial transactions.....	26
Figure 10. World exports of recovered plastics to China including HK in 2011.....	26

Figure 11.	UK Exports of waste plastics to China and Hong Kong SAR.....	28
Figure 12.	Japanese exports of waste plastics by destination country.....	29
Figure 13.	USA exports of waste plastics by destination country.....	30
Figure 14.	ASEAN net flows (exports-imports) of plastics scrap.....	31
Figure 15.	Relative amounts of exports of waste plastics from ASEAN countries.....	31
Figure 16.	Composition of UK Exports of Waste Plastics to China including Hong Kong SAR.....	32
Figure 17.	Improvement in quality of plastic waste bales in Japan, as a result of legislative initiatives Japan Containers and Packaging recycling Association (JCPRA).....	33
Figure 18.	Improvement in quality of plastic waste bales in Japan, as a result of legislative initiatives Japan Containers and Packaging recycling Association (JCPRA).....	33
Figure 19.	Composition of USA exports of waste plastics to China including Hong Kong SAR.....	34
Figure 20.	Demand for primary plastics in China.....	37
Figure 21.	Chinese waste plastics imports.....	39
Figure 22.	Estimated use of recycled plastics in China.....	40
Figure 23.	Total plastics recovery in China.....	40
Figure 24.	Photos from the Moore Recycling site visits in China in 2008-9.....	42
Figure 25.	Waste plastics stockpiled.....	45
Figure 26.	New PE reprocessing capacity built the last decade around the world. After Resource Recycling, as cited by Gwynn ⁴⁸	47
Figure 27.	Recovering plastics from a dump, Kathmandu, Nepal, 2013. Photo - De Visu / Shutterstock.com.....	52
Figure 28.	A Chinese woman holds her baby as she strips labels from plastic soda bottles so they can be recycled. If she works hard, she can earn about \$15 a day. Copyright: Peter Ford/The Christian Science Monitor.....	53

List of abbreviations

ABS	Acrylonitrile butadiene styrene
ASEAN	Association of South-East Asia Nations
BIR	Bureau of International Recycling
BPA	Bisphenol-A
CCS	China Customs Statistics
CEIN	China Economic Information Network
CLII	China Light Industry Information
EfW	Energy from waste
HDPE	High density polyethylene
HIPS	High impact polystyrene
ISR	Informal sector recycling
ISRI	Institute of Scrap Recycling Industries
ISWA	International Solid Waste Association
PE	Polyethylene
PET	Polyethylene terephthalate
PDBEs	Polybrominated diphenyl ethers
PEMRG	PlasticsEurope Market Research Group
PERNs	Packaging export recovery notes (UK)
POPs	Persistent organic pollutants
PS	Polystyrene
PVC	Polyvinylchloride
GFO	Green Fence Operation
GHG	Greenhouse gas
GWM	Globalisation and Waste management
LCA	life-cycle assessment
MFA	Material flow analysis
MRFs	Materials recycling facilities
NAFTA	North American Free Trade Agreement
RDF	Refuse-derived fuel

rPE	where 'r' stands for recycled, i.e. used polymer: used polyethylene, similarly for rHDPE, etc.
SAR	Special Administrative Area
SRF	Solid recovered fuel
STC	Scientific and Technical Chair
TF	Task Force
TFGWM	Task Force on Globalisation and Waste management
UN	United Nations
WDF	EC Waste Framework Directive
WEEE	Waste electrical and electronic equipment

1. Background: Globalisation and waste management

The report is part of ISWA's Globalization and Waste Management project, which is the first worldwide project dedicated to studying the linkages between Globalization and Solid Waste Management.

Globalization is one of the major challenges for the long-term sustainability of waste management and vice-versa. Appropriate waste management is one of the key conditions for sustainable globalization. There is an increasing need to focus on the linkages between globalization and waste management and to understand their nature.

Recognizing that globalization creates substantial changes and puts new and unprecedented challenges for waste management, ISWA established a Task Force (TFGWM) to study the linkages between Globalization and Solid Waste Management in September 2010. This report is part of the third work strand within the GWM scope, addressing challenges around **Global Recycling Markets, Material Flows and Trafficking**.

Previous research results, documents and summary reports are available on line through [ISWA's Knowledge Base](#). The final overarching results of the GWMTF work are presented in a report, where the current document is placed in context: **Final report of the ISWA Task Force on Globalisation and Waste Management**, September 2014, ISWA . The overarching report, this report and other main outputs can be downloaded from the Globalisation and Waste Management ISWA web-page.

TFGWM Members:

Project Coordinator: **Antonis Mavropoulos**, ISWA STC Chair, CEO D-Waste

Scientific Coordinator: **Prof David Wilson**, Visiting Professor at Imperial College London, and Independent Consultant

Editor: **Björn Appelqvist**, ISWA WGRWM Chair, Copenhagen Municipality

Jeff Cooper, Independent Consultant, Former ISWA President and Editor-in-Chief Waste and Resource Management

Dr Costas Velis, University of Leeds, Associate Editor Waste Management & Research

TFGWM Secretarial support:

Ms **Jiao Tang**

2. Introduction, aim and scope

Plastics are emblematic materials, transforming our everyday life for over 60 years, delivering unprecedented functionality. Plastics global production, mainly from fossil raw materials, has skyrocketed. At the same time a world-wide trade of used plastics has been established, in line with other major materials such as used metals and paper. Research1 has explained how major economic trends such as relocation of manufacturing to poorer countries and global long-distance supply chains have recently led to very important financial transactions and physical flows of waste-derived secondary raw materials: *"... in 2008, waste and scrap in general (North American Industrial Category 9100) exceeded semiconductors and components to be the most valuable export category from the USA to China, [using data from] US international Trade Commission DataWeb."*

This study aims to map the current status of global trade in plastic waste (plastic scrap, used plastic) and to identify the major existing and emerging challenges for the plastic waste trade stemming from globalisation. China, having being identified as the major international player (importer), is of key focus.

Often, specific examples using the case study of UK as a source (export) country and China as a destination (import) country are used, further detailed elsewhere².

3. Plastic waste trade and flows: key facts and factors of a global market

Global plastic production has risen rapidly in recent decades. The amount of plastics produced in the past 10 years equals to all of the plastics produced during the previous 30 years (from 1.5 million metric tonnes (Mt) in 1950 to 288Mt in 2012). The average annual growth was 4-5% during the past 5 years³. According to PlasticsEurope³ using PEMRG / Consultic data, most plastics in 2012 was produced in Asia (around 39.7% wt.), of which 23.9% wt. in China, followed by Europe (EU-27) (20.4% wt.) and the Americas (NAFTA: USA, Canada and Mexico with 19.9% wt.). This constitutes a shift of production from the West to Asia. PlasticsEurope opines that this production shift coincided with a stricter European regulatory regime.

Regarding waste plastics, the annual global trade of used plastics (domestic and exported) was 15Mt in 2007 and it was recently predicted by Pöyry to reach 45Mt by 2015⁴. A worldwide demand for 85Mt recovered plastics is estimated for 2020.

BIR on their web-site estimate the worldwide trade of waste plastics per year (also referred to as 'plastic scrap') at a total of 12Mt, valued at \$5 Billion (Bil)⁵. Cumulative UN Comtrade data⁶ officially reported larger values: the overall world exports were \$6.6 Bil, and overall imports 9.5 Bil, (corresponding to ca. 14.4Mt of material exported and 15.8Mt of material imported). The difference

in values is explained by the exports being accounted for on the basis of

KEY FACT 1

Waste plastics traded internationally are a small fraction of annual new plastic production (<5% wt.).

FOB (free on board) and the imports on the basis of CIF (carriage insurance and freight) (See **Section 4.1 - Table 1** for details). To put these numbers in perspective, this 15.8Mt of imports is around 5.5% wt. of the annual new plastic production (288Mt - 2012 PlasticsEurope values). Some of the non-packaging plastics produced remain in use for a period of years; or when they become waste, they are either stocked as scrap by merchants/intermediaries, used within countries, disposed of in landfills, recovered for energy production, or dumped without controls, with some ending up in undesirable places, such as beach litter and marine debris. Despite that, this comparison does not take into account any stocks or the relatively small percentage of plastic scrap traded compared to new plastics which suggests that as a whole we are

still far from extracting sufficient value (recycling and energy production) via international trade. A country-specific example² (UK) is examined in **Section 3.2 - Figure 2**, where the exported quantity for 2009 (0.7Mt) was 14.8% of the manufacturing of new plastics (4.8Mt), almost three times the global average, possibly due to high export rates for waste plastic in the UK in comparison to other European countries.

3.1 Recycling and recovery of waste plastics: comparative EU data

Figure 1 shows the overall recovery rate of post-consumer plastic waste across Europe for 2012. The overall recovery is split between collection for recycling (noted as 'recycling') and energy recovery. With regard to energy recovery, no differentiation is made between material recovered in EfW plants, which meet the R1 criterion for conversion efficiency and are legally a 'recovery' operation, and those plants not meeting the R1 criterion which are legally a 'disposal' operation

(Figure 1) implement strict restrictions on landfill disposal. Between 2006 and 2011, there was an overall improvement in the overall recovery rate (4-5%), but this global figure conceals very different rates and direction of change: the biggest improvement were for Estonia (45%) and Finland (about 30%). However, countries that already had high levels of overall recovery, such as Denmark, Sweden and Switzerland, achieved improvement <5%, but shifted towards

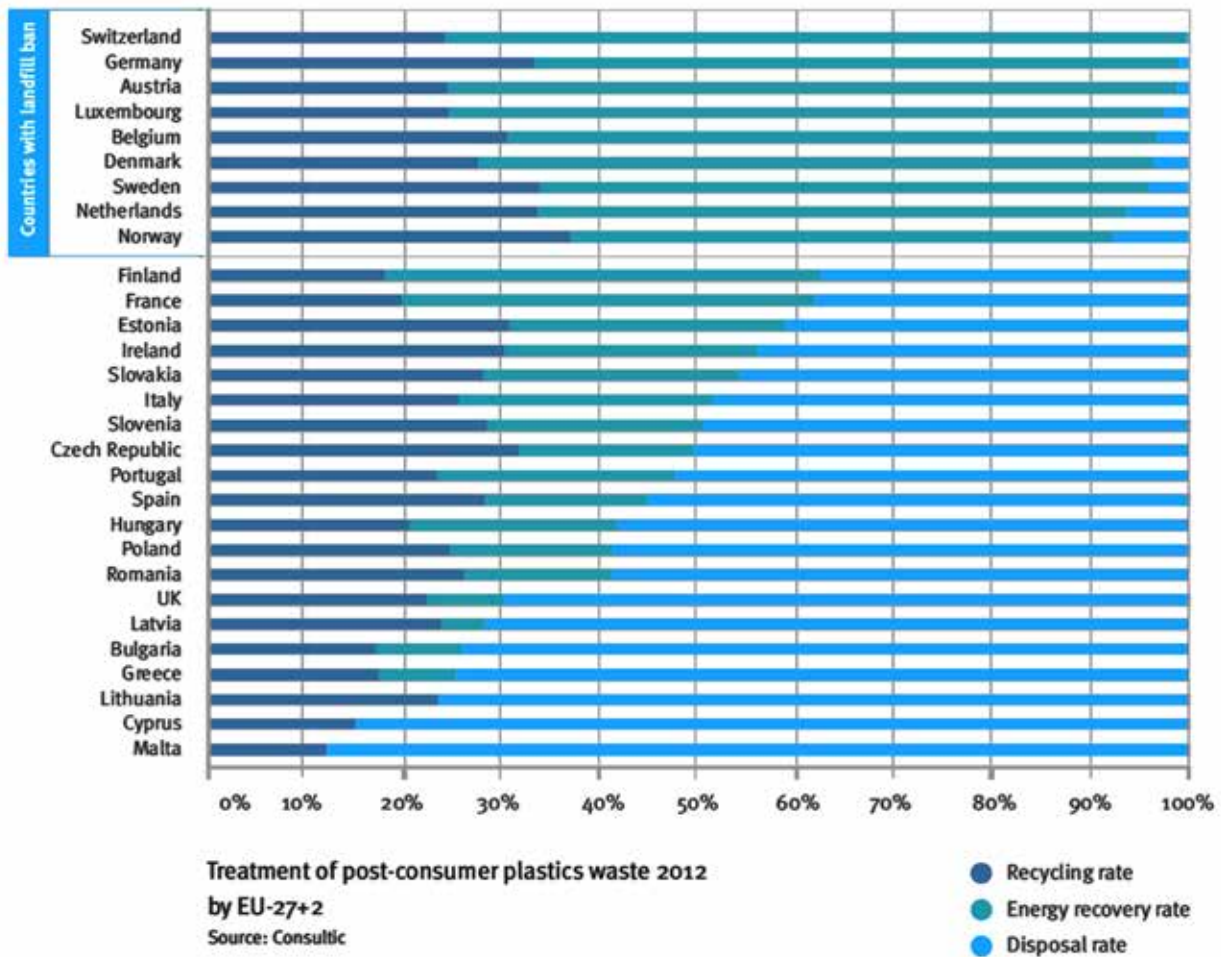

Figure 1. Recovery rate of post-consumer plastic waste by country 2012. Adopted from: Consultic, as cited by PlasticsEurope³

according to the revised EC Waste Framework Directive (WFD), nor between those plants for solid recovered fuel (SRF) thermal recovery. Recycling rates varied from 12% wt. to ca 38% wt. for Norway, and energy recovery rates from 0% wt. to over 75% wt. for Switzerland. The nine leading countries which achieved recovery rates over 90% wt.

lower energy recovery and greater collection for recycling. The highest shift from energy recovery to recycling, from 2006 to 2012, was for Denmark, with an increase of around 11-12 percent.

3.2 A specific example: the UK case

A detailed case study for recent plastics production, waste arisings, collection and recovery and export is available for the UK (Figure 2)². However, conclusions should not be generalised to the whole of Western Europe, as shown in Figure 1. In 2009, the UK converted 2.5Mt of raw materials into plastic polymers and processed 4.8Mt of polymers into plastic products. Assuming negligible exports and adding 0.8Kt of imported plastic products, it follows that 5.6Mt of plastic

was disposed of in landfills, 7.4% wt. was recovered via energy from waste (EfW), and 18.9% wt. was collected for recycling. Pre-consumer plastics waste ranged from 250-300Kt annually (Ktpa), and is largely recycled (> 90% wt.). The material flow diagram shown in Figure 2 summarises these findings, ignoring any stocks that arise from non-short life products.

Given the very high percentage disposed

northern European countries (e.g. Germany, Denmark), where the recovery via EfW is much higher. Hence, routes to optimal value recovery will be different based on the needs and baseline realities of each country. Of used plastics in the UK that were made available for recycling (pre- and post-consumer), around 70% wt. was exported, including both post- and pre-consumer quantities. Some of the material collected for mechanical reprocessing into materials

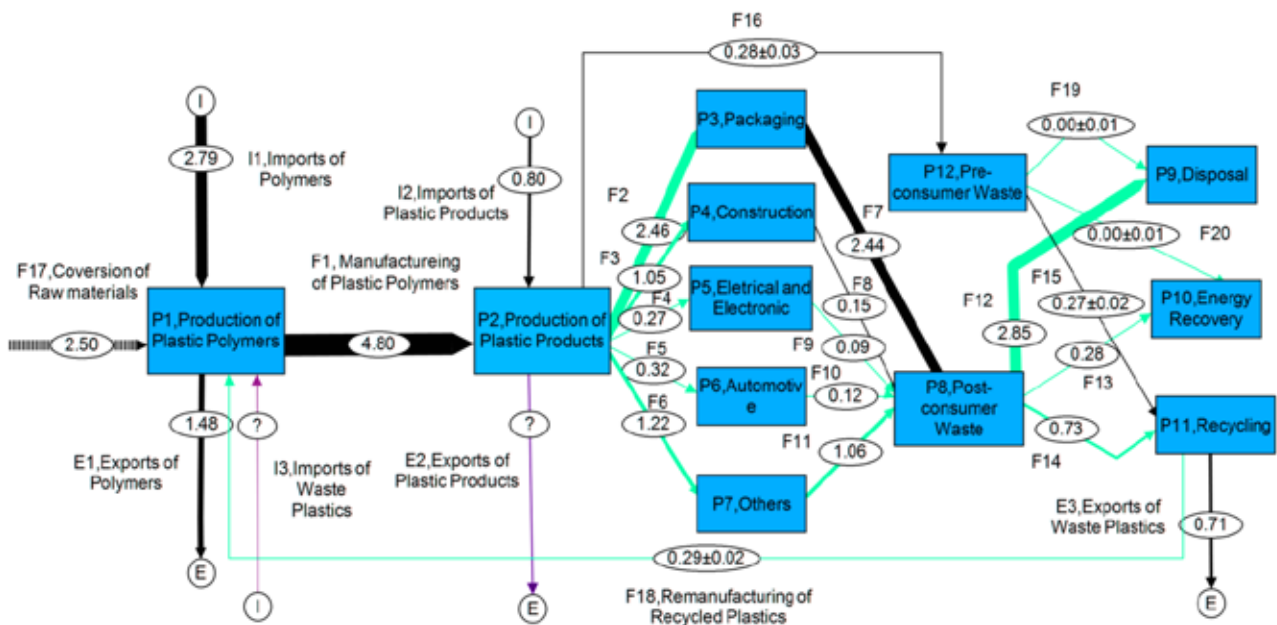

Figure 2. Material flow diagram for processing of plastics in the UK, 2009; quantities in million tonnes (Mt). According to the diagram, almost all post-consumer plastics collected for recycling were exported. Flows cover all consecutive stages of the life-cycle of plastics, involving production of plastic polymers (P1), production of plastic products (P2), consumption of plastics (P3-P7), waste generation (P12 and P8), waste management involving disposal (P9), energy recovery (P10) and recycling (P11), and trade (export, E). Stocks are not taken into account. Details of calculation and assumptions are available elsewhere².

products were put on the market.

Plastics consumption can be broken down into packaging, construction, electrical and electronic equipment, automotive and other types of plastic items. In the same year post-consumer plastic waste was 3.9Mt, of which 73.7% wt.

of to landfill, there is great potential to recover value from waste plastics in the UK, both in the form of recycling and via energy from waste (EfW) for the non-recyclable part. As it is evident from Figure 1, the ratio of waste plastic collected for recycling over the EfW is much higher than the central and

recycling facilities (MRFs) will be contamination or unrecyclable and it will end up in landfill / EfW or as refuse-derived fuel (RDF). Indicative reject rates of older technology plants (i.e. without advanced sensor-based sorting) in the UK have been provided by WRAP in 2006. Residue rates were reported at

12-15% of total input waste, with most effective at 2-5% wt.; but, this may not include all fractions disposed of ⁷.

There are considerable contrasts in the fate of pre- and post-consumer material. According to the Zhou 2 data and calculations, almost all of pre-consumer waste was recycled within the UK, while almost all of the post-consumer waste plastics collected for recycling was exported, the vast majority to China. Regarding plastic bottles only, of the respondents to a RECOUP survey, specifically to the question on where their plastics material was sold ⁸, 53% identified a UK market, 9% an export market (7% non-EU and 2% EU) and 38% were not aware of or willing to disclose the end market. To put things in perspective, ignoring stocks, the amount exported as a percentage of the plastics products sold (produced or imported) in the UK is therefore estimated at 12.7% wt. A detailed description of the supply chain or plastic recycling in the UK is available by Wong⁹.

The UK exported 711Kt of recycled plastics to other countries (**Figure 2**), which slightly increased to 736Kt in 2010, representing a considerable growth in comparison to 2007 (548Kt). This can be attributed to increased demand from the Chinese market. The economic downturn initially had a dramatic impact, with prices collapsing for a short period, but overall the quantities have continued to increase, albeit at a slower rate, although the value has decreased significantly due to the fall in prices. The UK used Hong Kong SAR as a key destination, because mainland China did not accept shipments of mixed PE, PVC, PS and PET with other polymers in the same container. However, UK exports to Hong Kong SAR declined significantly to 53% wt. in 2011, after China imposed stricter quality standards and law enforcement on materials for recycled materials shipped via Hong Kong SAR. The major competition facing the UK is

recycling from Chinese domestic waste and other major exporting countries. The UK exports to China are of relatively low quality compared with waste

in **Figure 26**, showing lack of investment in reprocessing facilities in the decade up to 2010. For the same reasons the ample availability of used plastics in

KEY FACT 2

Pre-consumer (industrial) plastic scrap, a by-product of industrial activities, is recycled as feedstock to a very high extent already (e.g. see the UK case study). The big challenges are with the post-consumer plastics, and especially those arising from mixed ('co-mingled' (UK)/ 'single stream' (USA)) collection, sent for mechanical recycling. Plastic waste present in residual waste (ideally limited to the non-sustainably recyclable part of waste) in most of the cases can potentially be directed to energy recovery via production of quality assured solid recovered fuel (SRF) or via energy from waste combustion plants (EfW) producing combined heat and power (CHP).

plastics sold to UK reprocessors, but they are of good quality compared with Chinese domestic recycled waste due to the high quantities of polluting additives/surfactants in the latter. Regarding international competition, the USA is the largest source country to China, and it is generally regarded as providing the best quality of waste plastics. Recent data suggest that the USA is increasingly reprocessing more waste plastics domestically, markets being readily available because it is the second largest plastics consumer in the world. However, regarding the USA, there is some contradictory evidence presented

Europe and Japan in principle enables further development in their local reprocessing capacity. However it may necessitate greater economies of scale – a striking difference from the current small-scale reprocessing operations in China. The latter may change as the Chinese government invests in larger scale facilities and attempts to eliminate the illegal, but very small scale, part of the sector (**see Chapters 6 and 7**). Japan is becoming an increasingly favoured import source for China, reflecting the lower currency and logistic costs, and higher actual or perceived quality.

3.3 The globalised plastic waste trade

The UN Comtrade map of exports for 2011 (code 3915: "waste, parings and scraps of plastics") readily visualizes this global dimension (**Figure 3**). The flows are mainly from affluent Western/Northern countries to Asian countries and specifically to China, which dominates the global market.

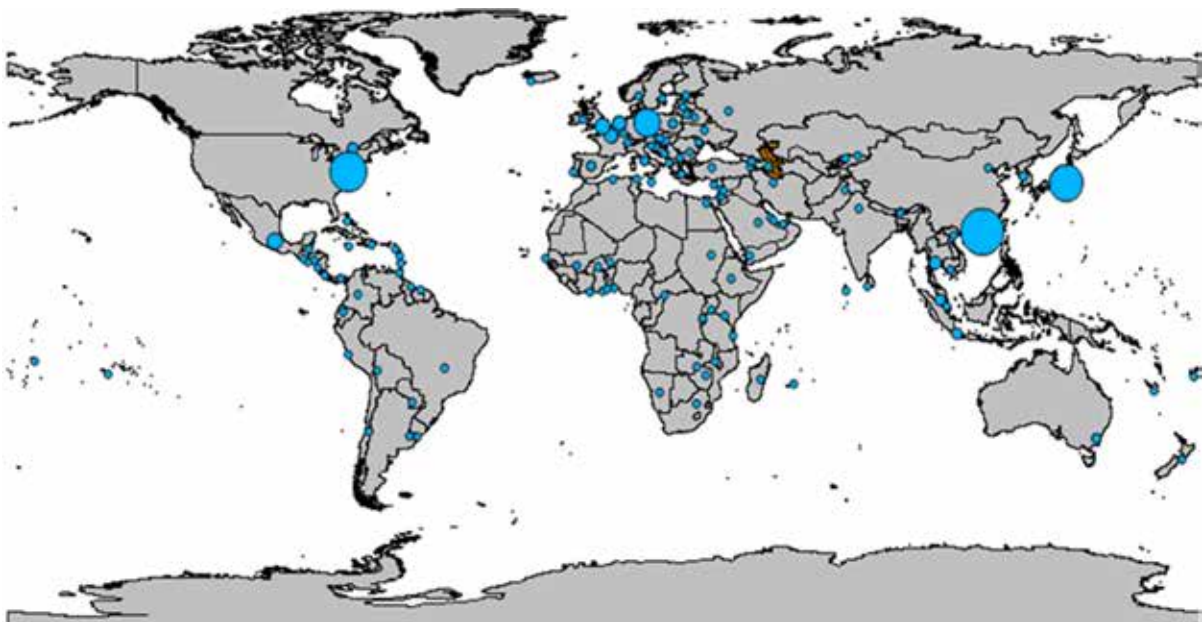

Figure 3. Global map of export transactions in waste plastic in 2011. Data source: UN Comtrade.

KEY FACT 3

Waste plastics are traded in a globalised supply chain and market.

3.4 Key market factors

International recycling markets for plastics scrap depend on a complex interplay of:

1. National (domestic) solid waste collection capabilities (formal and informal), reprocessing capabilities and needs, and export / transport laws and controls.
2. Market demand and import controls at the major destination countries (e.g. China) and investment in raw material production elsewhere (e.g. Chinese investments in Africa).
3. Global supply chain networks: transport logistics and costs (westbound freight rates, number of empty containers returning to Asia ("reverse haulage"), customs).
4. Cost of primary resins, dependent on oil and natural gas prices (prime determinant of the price of recycled plastics)
5. Technological innovation: (new resins, composites, oxo-degradable and compostable plastics, sensor-based sorting, chemical recycling).

KEY FACT 4

Many industrial sectors are involved: traditional waste management, informal sector collectors, reprocessors, transporters/forwarders, local and multi-national manufacturers.

KEY FACT 5

The current mode of operation balances the trade deficit of the Northern/Western countries, utilises the otherwise empty containers (reverse haulage) and supplies Chinese manufacturing industry with necessary affordable secondary raw materials.

3.5 Waste plastics markets vulnerability and volatility

The market (amounts traded) for waste plastics has been continuously increasing over the last decade but with a disruption during the 2008-9 financial crisis, which coincided with the collapse of primary plastic production. According to Zhou², in 2008, China, as a key destination of waste material in global market, reduced purchasing of recovered paper and plastics as a result of the fall in demand from Chinese packaging firms. It has been estimated by Moore¹⁰ that, as a result of the global financial crisis, around 38% of plastic recycling firms in China stopped operating by the end of 2008. Exporters to China had to stockpile large quantities of recyclable waste and suffered losses. According to Letsrecycle.com¹¹, the price of waste plastics in the UK fell abruptly: used plastic film

(ex-works, usually baled) was traded at £20-£50 per tonne in December 2008, down from £130-£170 per tonne earlier that year; and the price of waste 'natural' grade rHDPE bottles (the type and quality of waste plastic traded at the highest prices) fell from £260-330 in November to

130-150 in December. In response, European recycling market tried to limit the supply to China in order to prevent or reduce a loss. Thus many projects were brought to a halt and production was substantially reduced. Steady economic growth during the summer of 2009, made the Chinese market

KEY FACT 6

A steady market increase is in direct relationship with primary plastics production. Decreases in the prices of primary plastics directly affect the prices and trade volume of secondary plastics.



Figure 4. Production index of primary plastics. After PlasticsEurope³, using EUROSTAT data.

for imported waste plastics available again. By May 2009 the high price of used plastics had been restored.

Figures 4, 5 and 6 demonstrate the interrelationships between the international financial climate, primary plastics production, plastic waste prices and the financial value of exports.

The 2008 financial crisis impacted on all these variables. The crisis also had implications on the main plastic scrap importer: in China a considerable proportion of the small-scale Chinese reprocessors were forced out of business (38% of plastic recycling firms closed¹⁰ at the end of 2008).

Another big effect of global market disruption was due to the implementation of stricter custom controls by the Chinese government known as the 'Green Fence Operation' which is detailed in Chapter 7. However, prices were not been affected to the same extent.

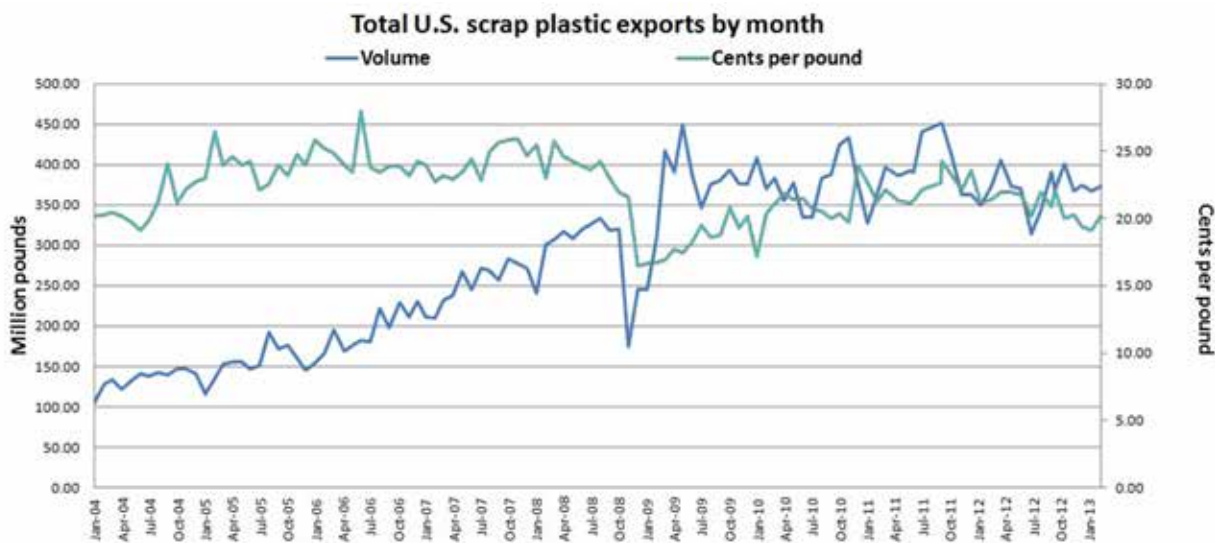

Figure 5. US waste plastics exports: The abrupt drop in 2008 coincides with the financial crisis and the drop in the production and prices of the primary plastics (Figure 4). After Resource Recycling¹².

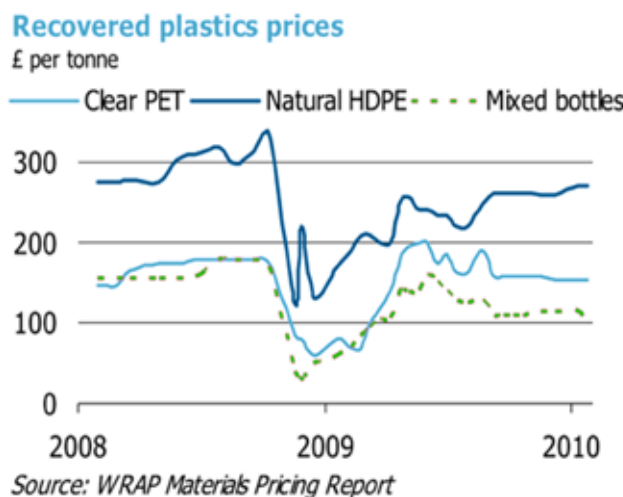

Figure 6. Prices of reprocessed waste plastics in the UK market, for various grades: the collapse in prices corresponds to the financial crisis which has resulted in fall in the production index of primary plastics³. Adopted from WRAP¹³.

4. Main trans-boundary flows of plastic waste (imports–exports)

4.1 The big picture

The aggregate world value of waste plastics according to the UN Comtrade data for 20126, (3915 data code, financial values in \$) are shown in **Table 1**. The overall exports was at \$6.6 Bil, corresponding to ca. 14.4Mt of material traded; the imports at ca 9.5 Bil, corresponding to 15.8Mt. The top

world importers were: No1: China at 73.1% at \$6.1 Bil, No2: Hong Kong SAR 19.7% at \$1.65 Bil. The top 5 importers were (**Figure 7**): China > Hong Kong SAR > USA > Netherlands > Belgium.

Table 1. World value of waste plastics trading (exports – imports) according to the UN Comtrade data for 20126, (3915 data code, financial values in \$).

Trade Flow	Trade Value	NetWeight (kg)	Trade Quantity
Export	\$6,606,944,815	14,428,897,482	14,428,897,482
Import	\$9,459,409,205	15,853,971,409	15,853,971,409
Re-Export	\$972,369,133	2,972,712,246	2,972,712,246
Re-Import	\$1,038,381	1,352,208	1,352,208

Top 5 importers

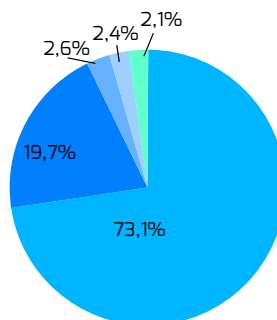

Top 5 exporters

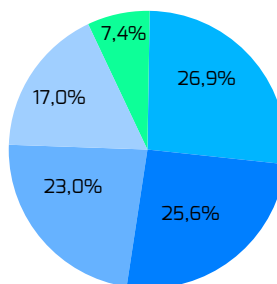

Figure 7. Top importers and exporters of plastic waste worldwide, based on financial transactions. Source: UN Comtrade - data for 2012.

4.2 China

China is the largest importing country for waste plastics, representing around 56% wt. of the global market. Between 2006 and 2012, plastic waste imports increased from 5.9Mt to 8.9Mt, an annual growth rate of around 7.4%. USA remains the largest source country to China, accounting for 21%, followed by Japan (18%), Germany (12%)

and the United Kingdom (9%). In financial terms, if the percentage of Hong Kong Special Administrative Region (SAR) is added to that of China (almost all that enters HK SAR is re-exported to China – see **Section 4.4**), then China (2012) accounts for the 49% of the global financial activity of plastic scrap imports, according to UN Comtrade data.

KEY FACT 7

China, including the Hong Kong SAR, is the key player in the global market for plastic waste, being by far the biggest importer (49% of financial transactions for imports – 56% wt.).

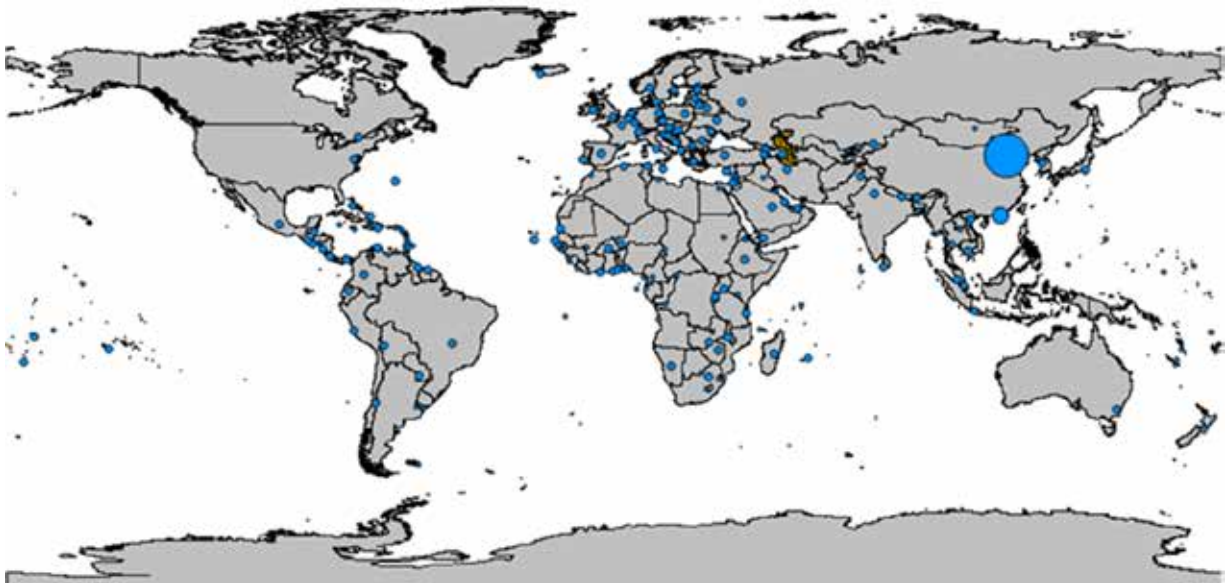

Figure 8. Global map of import transactions in waste plastic in 2011. Data source: (UN Comtrade).

Top 5 import partners for China

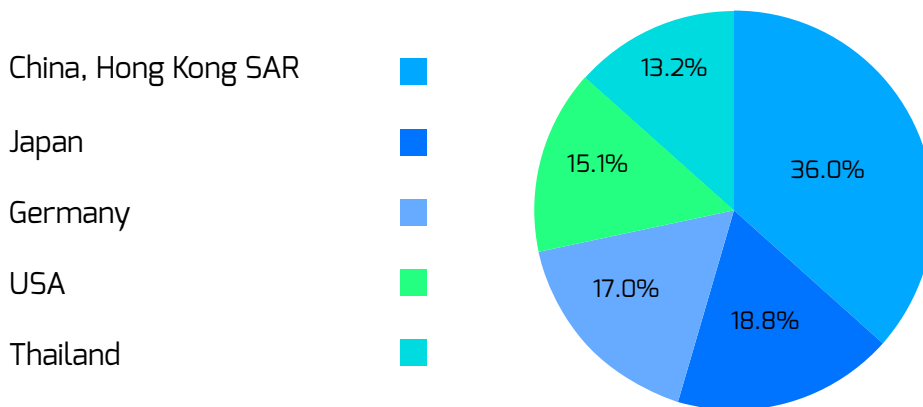

Figure 9. Top importers of plastic waste to China, based on financial transactions. Source: UN Comtrade - data for 2011.

The top five exporters in the world were: Hong Kong SAR > USA > Japan > Germany > UK. Europe collectively is the major exporter. An overview of the most important exporters to China is provided in **Figures 9** and **10**. Some of these exporting countries/areas are considered in more detail below.

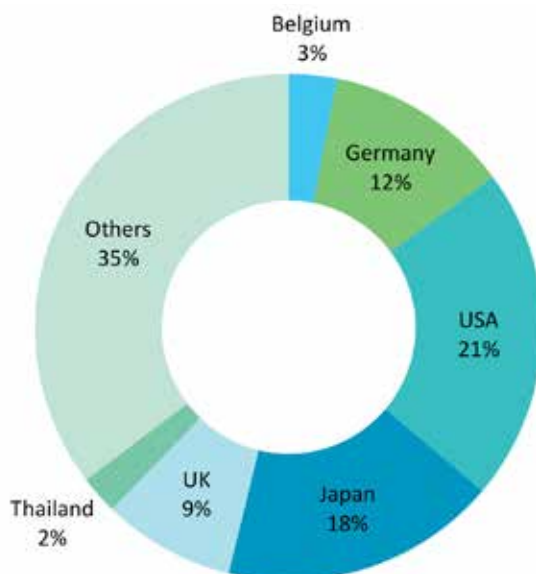

Figure 10. World exports of recovered plastics to China including HK in 2011. After Zhou² (Data Source from UN Comtrade).

4.3 Europe (EU-27)

KEY FACT 8

Europe, the biggest exporter worldwide of waste plastic intended for recycling, depends largely on China: 87% wt. is exported to China either directly or via the Hong Kong SAR. The exported quantity is 46% of the overall quantity collected for recycling, and 12% of the entire plastic waste arisings in Europe. In contrast, Europe exports only 1.2% of its primary plastics products to China. High dependencies on exports to China also hold for Japan and the USA.

According to PlasticsEurope data for 2012³, the EU-27 generated 25.2Mt of post-consumer waste plastics, quantities remaining almost stable since 2011. Of these, ca 6.5Mt (26% wt.) was collected for mechanical recycling, 0.3% for direct feedstock recycling, and 35.6% (ca 8.9Mt), was sent for energy recovery, with the remaining being landfilled. According to BIR 2011 data, from the 6.4Mt collected for recycling, 3Mt was handled within Europe, and 3.4Mt exported outside Europe. Therefore more than half of the plastic waste collected for recycling in Europe is directed to international markets. According to EUROSTAT 2012 the EU-27 data (EUWID web; 15-04-13,

EUROSTAT 2012 data, 27 countries), Europe exported 3.36Mt (Waste, parings and plastics scrap), worth €1.7 Bil (Extra-EU trade). The trend is relatively stable: 2010: 3.373Mt; 2011: 3.365Mt; 2012: 3.358Mt. According to UN Comtrade data⁶ EU-27 exported mainly to Asian countries, with China 1.9Mt and to Hong Kong SAR 1.04Mt – altogether 2.9Mt (**Table 2**), comprising 87% wt. of the exports. This amount constitutes 46% of the overall quantity collected for recycling; 12% of the entire post-consumer plastic waste arisings in the EU-27; and only a mere 3.4% of the 85Mt predicted by a Pöyry report as the worldwide demand for used plastics by 2020 – inevitably

with high uncertainty⁴; and only 6.4% of the demand for the Chinese market by 2015 as predicted by CBI China 4. There is a rising trend of direct exports to China, and also to India. Given that the exports from Europe to South-East Asian countries to a great extent finally find their way to China, the overall dependence on Chinese market demand is even greater. In contrast to the 87% wt. of waste plastics, Europe exports only 1.2% wt. of its primary plastics products to China³. The EU-27 imports were just 0.4Mt, with outside Europe countries making a negligible contribution, and Norway and Switzerland being most important EU-27 suppliers.

Table2. Financial value and weight of EU-27 waste plastics trading (exports – imports) according to the UN Comtrade data for 2012⁵, (3915 data code, financial values in \$).

Trade Flow	Reporter	Partner	Trade Value	NetWeight (kg)	Trade Quantity
Export	EU-27	World	\$1,372,115,961	3,357,671,864	3,357,671,864
Export	EU-27	China	\$767,228,422	1,886,100,100	1,886,100,100
Export	EU-27	China, Hong Kong SAR	\$398,812,843	1,037,642,200	1,037,642,200
Import	EU-27	World	\$96,825,536	398,968,092	398,968,092
Import	EU-27	China	\$2,183,884	2,017,904	2,017,904
Import	EU-27	China, Hong Kong SAR	\$340,347	455,350	455,350

4.4 Hong Kong: China Special Administrative Area (SAR)

KEY FACT 9

The Hong Kong SAR serves almost exclusively as an alternative entry point for the Chinese market – it used to be considered a more lax entry point.

The Hong Kong SAR has no internal market for plastic waste. It is exporting most of the domestically collected plastic waste arisings. According to the Waste Reduction and Recovery Factsheet No4., in 2011 0.84Mt were collected by co-mingled separation

(3.20Mt), was re-exported to the World (2.93Mt), essentially China (2.86Mt). This is done after preliminary cleaning and sorting. Total exports from Hong Kong SAR to China were at 3.16Mt (a bit less than the addition of the re-exported 2.86 plus the domestically collect-

Hong Kong SAR is a key destination of UK waste plastics exports, accounting for around 88% in 2010, which reflected UK dependency on Chinese market 15. The UK used to choose Hong Kong SAR as a key destination, because it allowed imports of mixtures, while

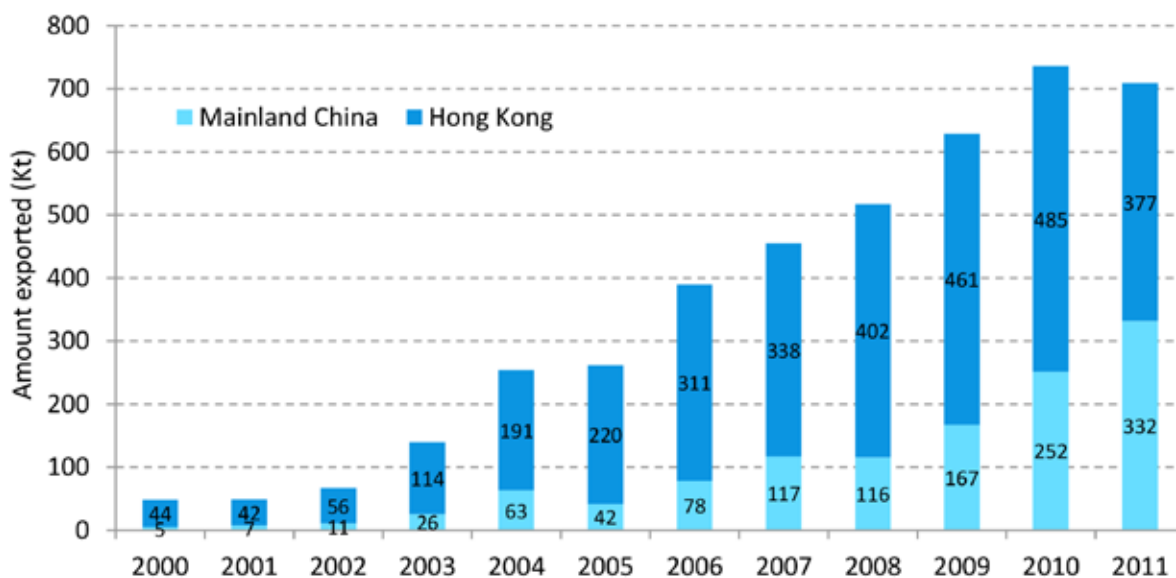

Figure 11. World exports of recovered plastics to China including HK in 2011. After Zhou² (Data Source from UN Comtrade).

programmes, which were exported mainly to China (99.5% wt.), with minor quantities directed to Vietnam (1.9% wt.) and Taiwan (0.1% wt.). The exports have two processing routes. Most of it is baled by local commercial recyclers for direct export. At Plastic Resources Recycling Centre EcoPark Tuen Mun, the remainder is reprocessed: cleaned, crushed, dried and the shredded flakes are pelletised.

According to UN Comtrade⁶, most of the 2012 imports to Hong Kong SAR

ed and exported 0.83 which equals to 3.69Mt) – and to the world 3.24Mt. It is speculated that Hong Kong SAR was preferred over direct export to China because of more lax import rules and enforcement. However, this may not be the case currently, as the case of the UK indicates (See Section 3.2).

A special case is the UK, which is the only major plastic exporter country that tranships more recycled plastic to HK than directly to mainland China. According to Zhou², China including

mainland China only allowed mixtures of waste plastics that included PE, PVC, PS and PET. Figure 11 shows that 78% of UK plastic exports to China were shipped to Hong Kong SAR in 2008, but the relative proportion declined significantly to 53% in 2011. There is anecdotal evidence that plastics from imported WEEE were separated from metal scrap in HK and then transhipped to China². Stricter administration effectively prevented unqualified waste plastics from entering mainland China.

4.5 Japan

Based on UN Comtrade⁶ data, Japanese exports of waste plastics have shown small fluctuations of between 1450-1650Kt in the past five years, with the majority transported to Hong Kong SAR and China (**Figure 12**). Before 2009, Japan used to ship more waste plastics to Hong Kong SAR than directly to mainland China, which was reversed from 2009

onwards. From 2011 to 2012 total exports were constant, and the shift towards more direct exports to China i.e., less via Hong Kong SAR was ever stronger: 2011: China 0.90Mt, HK: 0.59Mt, Total: 1.49Mt; 2012: China 1.05Mt, HK: 0.46Mt, Total: 1.51Mt).

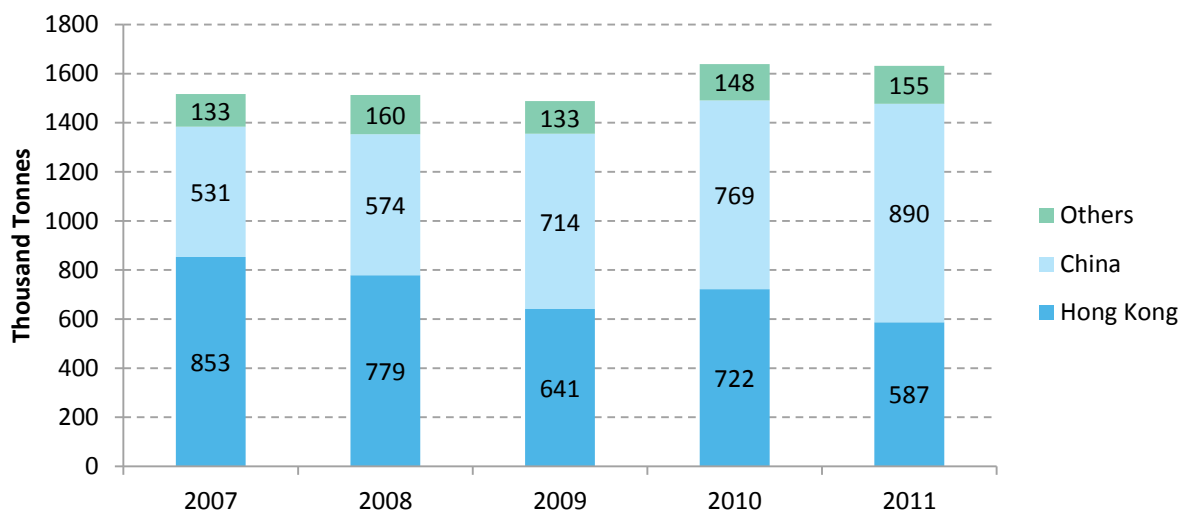

Figure 12. Japanese exports of waste plastics by destination country. After Zhou² (Data Source from UN Comtrade, 2012)

4.6 USA

2.1Mt worth of \$1.05 Billion



USA is the largest waste plastics supplier to China

The USA is the second largest consumer of plastics in the world and depends mainly to China and HK for absorbing its waste plastics. Neighbouring countries such as Canada and Mexico are also a small market outlet. According to the Institute of Scrap Recycling Industries (ISRI)¹⁶ reporting data from the U.S. Census Bureau, the

USA exported 2.1Mt of plastic waste, worth \$1.05 billion. Most of the value of the transactions was with China and the Hong Kong SAR (\$547 million and \$240 million respectively).

From a Chinese perspective the USA is its largest supplier of waste plastics. Out of 2.15Mt exports in 2012, China absorbed 1.20Mt and HK 0.49Mt – in total 1.69Mt, accounting for 0.79% wt. A slight decrease was noted in comparison to 2011 (out of 2.14Mt: China 1.18Mt, HK: 0.60Mt, Total: 1.78Mt = 0.83% wt.). Overall exports increased by 54% between 2007 and 2011 (**Figure 13**), largely reflecting the doubling of the quantities exported to China.

China’s market share increased from 39.2% in 2007 to 54.8% in 2011, gradually dominating the USA exports.

In comparison, exports of waste plastics to the Hong Kong SAR were comparable with exports to China during 2007-2009, declining substantially afterwards.

This fact could indicate quality improvements of exported waste plastics, as the Hong Kong SAR has a relatively low import threshold for waste plastics. Despite these exports, domestic USA reprocessors import large quantities of waste plastics every year to meet their demand.

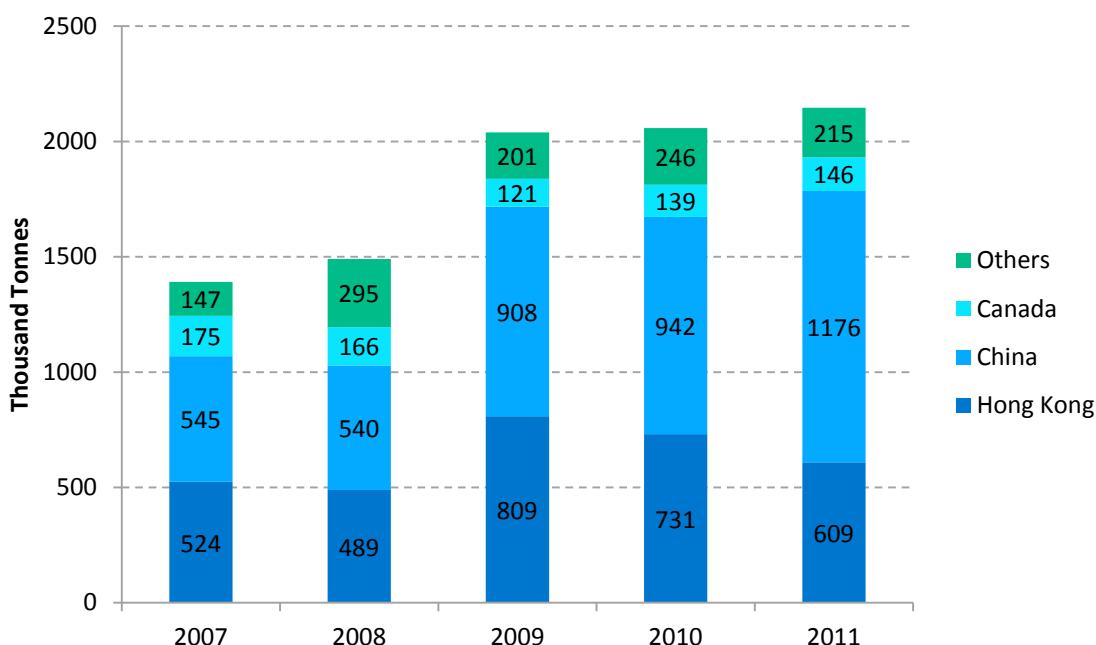

Figure 13. USA exports of waste plastics by destination country. After Zhou² (Data Source from UN Comtrade, 2012)

4.7 South-East Asia (ASEAN)

The 10 countries of the South-East of Asia region (Malaysia, Singapore, Brunei Darussalam, Thailand, Philippines, Vietnam, Myanmar, Indonesia, Cambodia and Lao PDR) are part of the Association of South-East Asia Nations (ASEAN). They import around 3% wt. of the global trade (2011 data) and export around 5% of the global trade. This denotes a discrepancy; it is not clear whether the domestic collection of plastic can account for such exports (Figure 14). A detailed study at the University of Leeds¹⁷ on the plastic scrap imports and exports for the region suggests that ASEAN countries play a role of intermediate processing or re-export destination for material that eventually reaches China. The small quantities that are exported to Western/Northern countries are likely to be of higher quality and have undergone extensive reprocessing. However, there is considerable data uncertainty due to poor data availability and reliability.

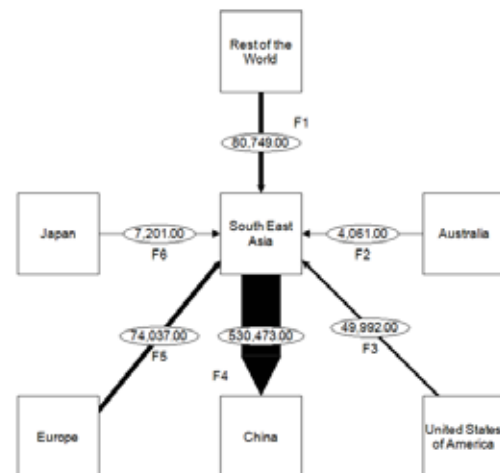

Figure 14. ASEAN net flows (exports-imports) of plastics scrap. After Oon17.

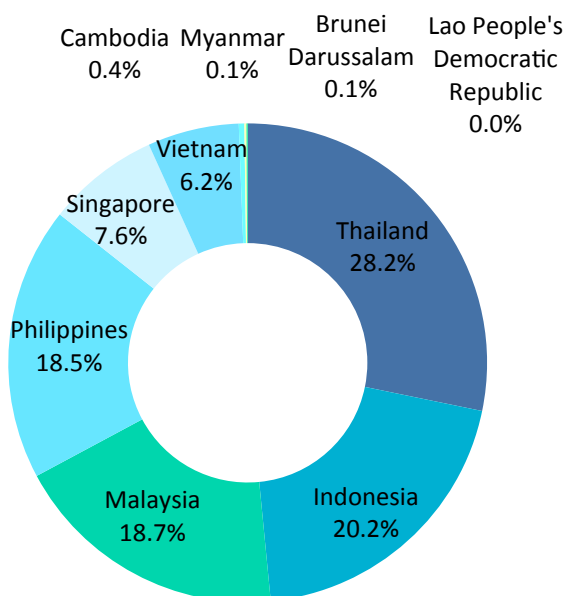

Figure 15. Relative amounts of exports of waste plastics from ASEAN countries. After Oon17.

KEY FACT 10

ASEAN countries (mainly Vietnam, Malaysia and Indonesia) export to China, possibly re-exporting reprocessed waste imports and exporting domestically collected plastic scrap.

5. Exports of different polymer types to China and Hong Kong.

5.1 UK

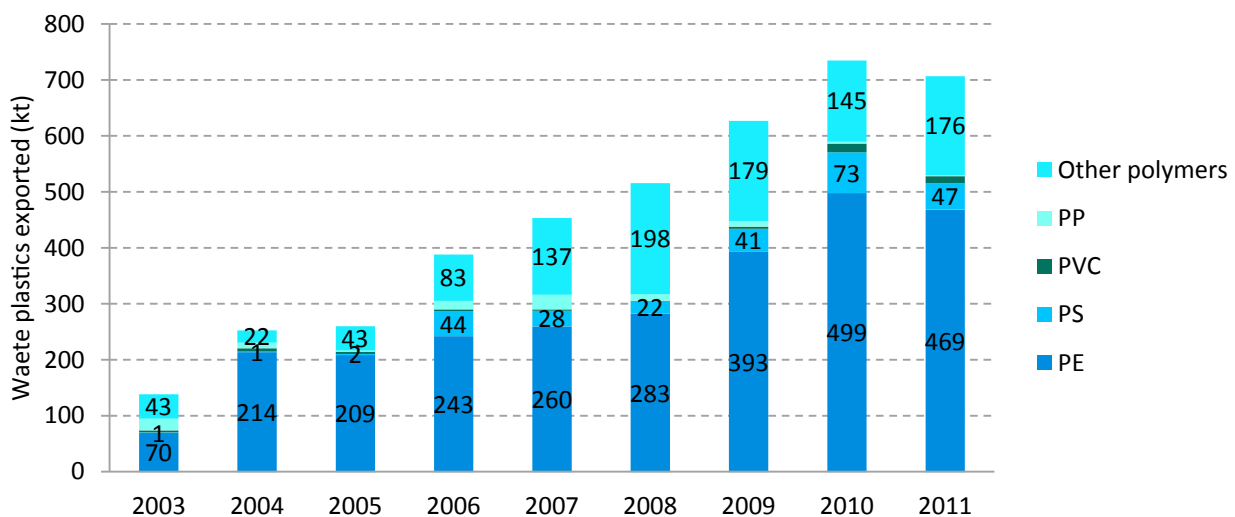

Figure 16. Composition of UK Exports of Waste Plastics to China including Hong Kong SAR. Data source: HM Revenue & Customs¹⁴. After Zhou².

According to Zhou², based on data from HM Revenue & Customs¹⁴, the UK exports of rPE (where 'r' stands for recycled, i.e. used polymer) increased significantly between 2003 and 2011, peaking at 498.6Kt in 2010 (**Figure 16**). As the UK also imports rPE from other European countries, it indicates competition between Chinese and UK remanufacturers, with UK remanufacturers being possibly disadvantaged. Exports of rPS jumped from 1.5Kt in 2005 to 43.8Kt in 2006, followed by a market share fluctuating

widely between 4% and 11%. Exports of rPVC ranged 1-6Kt from 2003 to 2009, and for the first time exceeded 15Kt in 2010, followed by a slight decline in 2011. Exports of rPE, rPS and rPVC show a long term upward trend; but exports of rPP to China showed a marked decrease from 22.6kt to 3.4kt between 2003 and 2011. Other recycled polymers accounted for 20-30% (82.6-198.0Kt) of exports to China after 2005.

5.2 Japan

According to Zhou², Japan is the second significant source of waste plastics to China (Hong Kong SAR included) after the US. Most of waste plastics shipped from Japan to China are described as 'other waste plastics' of which PET is a significant fraction. The share of PE (21%-22%), PVC (1%-2%) and PS (14%-16%) have remained stable in recent years. Japan imposes strict limitations to landfill disposal which enables

to increase the recycling rate of PET bottles to more than 85% and to reduce their weight by more than 10%, according to The Council for PET Bottle Recycling¹⁹. As a result Japan is the largest supplier of recycled PET to China, accounting for 23% wt. of China's imports of rPET in 2009. In 2010 Japan collected 628kt of PET for recycling and 52.5% were exported, mainly to China. However, high-quality

recycled PET is also in demand in Japan as it is used for closed-loop recycling in bottles (11%), sheets (49%), fibres (34%) and other products (6%)¹⁹. In 2010 Japan exported 40% of its waste plastic bottles overseas, 90% of which were sold to China due to higher prices paid by the Chinese manufacturers (World Recovered Plastics, 2012). It has been suggested that Japan should restrict exports of waste plastic bottles to China to prevent the loss of precious and finite domestic recyclable resources.

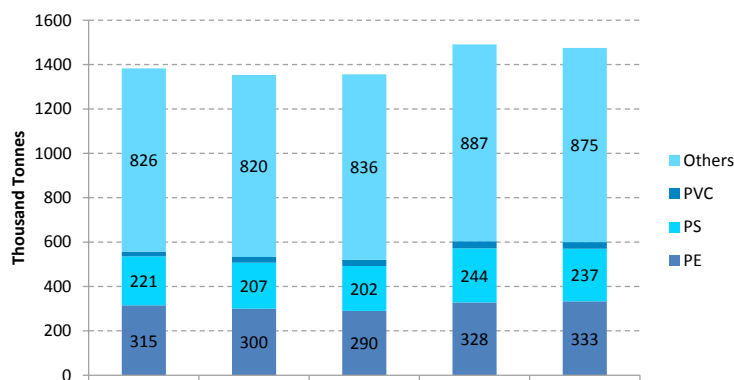

Figure 17. Composition of Japan's Exports of Waste Plastics to China including Hong Kong SAR. After Zhou² (Data Source from UN Comtrade, 2012).

considerable secondary plastics to be available for reprocessing and export. Japan has a very high collection rate for PET bottles, achieving 72.1% in 2010, facilitated by legal measures such as 'The Containers and Packaging Recycling Law' (1995), 'Chemical Bottle to Bottle (BtoB) Recycling' (2004) and 'The 2nd Voluntary Action Plan for 3R Promotion' (2011). These measures promote the quality of recycled PET bottles, with liquor, soy sauce and soft drinks bottles designated specifically for recycling. The Containers and Packaging Recycling Law requires reprocessing PET bottles into pellets, flakes or polyester raw material for recycling. The voluntary plan proposes

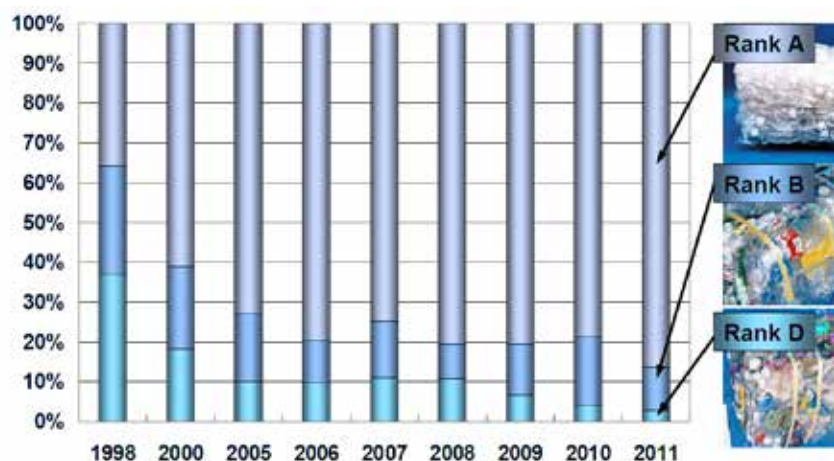

Figure 18. Improvement in quality of plastic waste bales in Japan, as a result of legislative initiatives Japan Containers and Packaging recycling Association (JCPRA), as reported by The Council for PET Bottle Recycling (CBPR)¹⁹

5.3 USA

According to Zhou² the composition of USA exports of plastic waste to China, including Hong Kong SAR, the category 'other plastics' accounts for around 60% of plastic waste (Figure 19). These 'Others' include rPET, rPP, etc. The USA collected 653kt of rPET bottles in 2009 of which 54% wt. were exported. 48% of 12kt of PP collected for recycling were purchased by ex-

level has remained relatively stable. In contrast, USA domestic reclamation capacity of mixed plastics has outstripped China's since 2008 and showed an upward trend, as the Moore Recycling Associates explained²⁰. However, according to Powell²¹, over the last decade US domestic PET reclaimers have lost market share to Chinese buyers for MRF outputs: 22%

amorphous and solid-state products. Kuczenski and Geyer²² argue that the fact that the low investment in reclamation capacity within the US was primarily due to the fact that rPET is an internationally traded commodity. Factors such as aggressive pricing and tolerance of contamination from exporters created most favourable condition for exporting, rather than

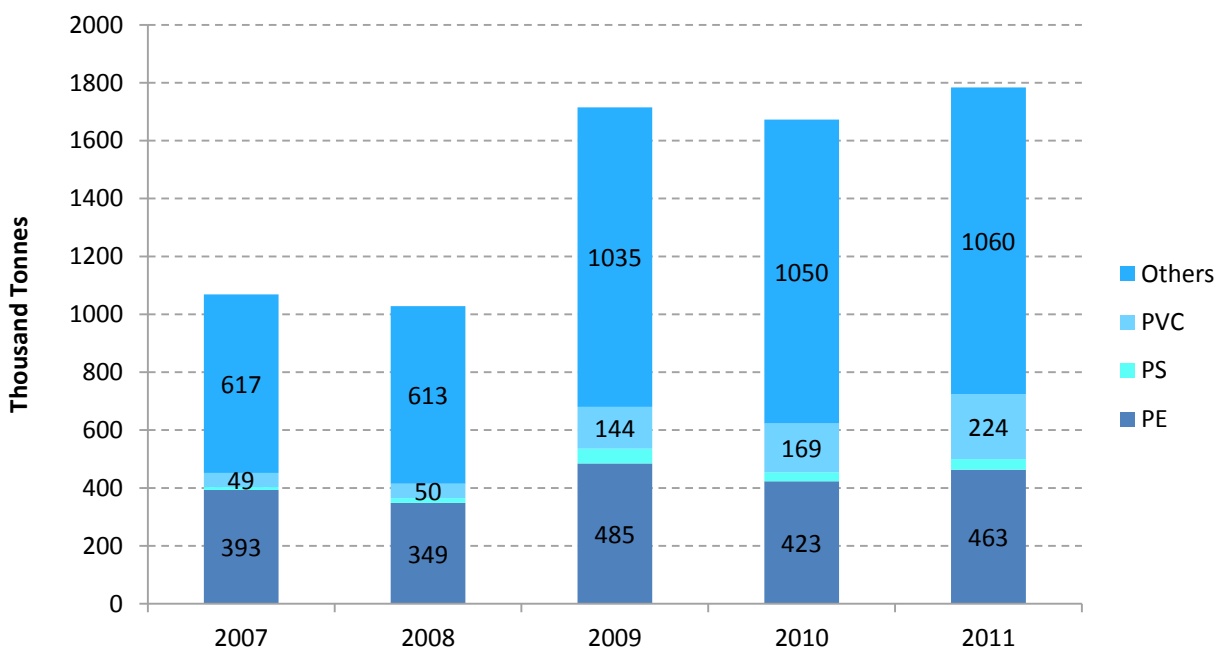

Figure 19. Improvement in quality of plastic waste bales in Japan, as a result of legislative initiatives Japan Containers and Packaging recycling Association (JCPRA), as reported by The Council for PET Bottle Recycling (CBPR)¹⁹

port markets. Exports of rPE and rPS increased moderately during 2007 to 2011. The most important recent development was the share of rPVC which soared from 4.6% to 14.3% during this period.

After a significant increase of total exports to China and HK in 2009, the

wt. in 2000, 50% wt.4 in 2010. A major material flow analysis (MFA) research study of the PET in the US for over a decade (1996-2007) has vividly demonstrated the complexities of a system that relies on both imports and exports²². rPET was shown as capable of competing with primary PET in manufacturing processes of both

reclaiming domestically. At the time the collection rate of post-consumer PET was low, with 80% wt. ending up in the landfill. The low collection rate of post-consumer PET was identified as the greatest obstacle for improving the "material efficiency of the PET system".

6. What happens within China?

KEY FACT 12

There is insufficient understanding of the fate of plastic scrap after entering China and consequently its implications for local and global health and the environment. The 'Green Fence Operation' has rapidly changed the import and utilisation situation.

Given the major dependence of the rest of the world on China's importing of plastic scrap (56% wt. of worldwide imports), the fate of this secondary resource within China is of great importance. Plastics manufacturing has emerged as a key priority for today's China²³.

Despite this there is insufficient understanding of the exact recovery conditions that prevail within China; with the language barrier also contributing to this limitation. There are concerns (see **Section 8.1**) that the material could be used for the production of lower quality plastics in violation of specifications; that the reprocessing and manufacturing techniques and conditions could potentially endanger the health of workers (occupational health) and increase risk to the public health via improper disposal in China and potentially worldwide via reprocessed exports.

There are also concerns that material of lower quality is not used, but is disposed of, or used for energy recovery in plants that do not have air pollution control (APC) systems in place of standards equivalent to the EU plants and for which use is contrary to the export laws of many countries, including the EU and even Chinese import laws. However, there is no definitive evidence to confirm or reject these concerns thus far.

The main findings from a research study by Zhou² attempt to cast light on the trade of waste plastics between the UK and China. Information and data were obtained on the Chinese market for waste plastics, and included reviews of data available only in Chinese. The literature

sources mainly comprised expert opinions obtained via questionnaires and reports. The most useful data sources were obtained from official organisations, such as the China Customs Statistics (CCS),

China Economic Information Network (CEIN), China Statistical Database and the organisation representing China Light Industry Information (CLII). Relevant stakeholders including selected EU recyclers, re-processors, exporters, Chinese importers and recyclers were interviewed. Having critically evaluated data on material flows and recovery activities, an analysis of the current and future demand of China for waste plastics was completed to assess the impacts on UK competitiveness in the global market.



Plastic figures of Chinese people on a market stand for sale

6.1 China: Production and demand for plastics

Due to its size and rapid financial development China has become a dominant player in the global recycling market, particularly for plastics, paper and metals. Given the prominent role of China in the global market for recycled plastic it is crucial to understand the dynamics that affect this market, including the demand within China and the fate of imported waste plastics.

China is now one of the top consumers of plastics. The consumption of plastic products grew rapidly from 22kg per capita (kg p⁻¹) in 2005 to 46kg p⁻¹ in 2010²⁴. Hence sufficient supply of plastic resources is becoming increasingly important. Scarcity of plastic raw material has been a continuing problem in China, and recycled plastics are

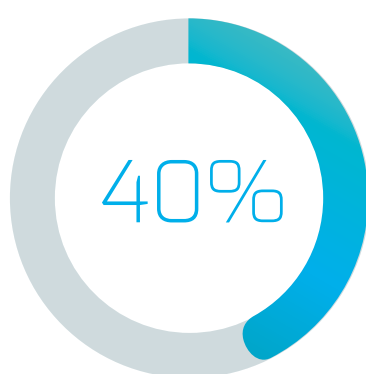

By weight of world production is now in Asia,

with 20% each in Europe and North America - China is the largest individual country at 24%.

valuable sources, to cover this need²⁵. The long term demand for waste plastics in China is closely related to the gap between the supply and demand of primary plastics. The capacity of the

domestic petro-chemical industry has developed dramatically. The production of synthetic resins doubled over six years, reaching around 48Mt in 2011. This Chinese domestic supply is

Table 3. Chinese plastics production and types of plastic products (thousand tonnes). Data sources: China Statistical Database^{28,a}; China Customs Statistics (CCS)^{27,b}; IRR^{29,c}; China Economic Information Network (CEIn)^{30,d}; Liao^{31,e}

Products		2005	2006	2007	2008	2009	2010	2011
Construction Material*	Profiles	2558 ^c	3084 ^c	3191 ^d	3569 ^d	3302 ^d	3856 ^d	
	Pipes and Ducts	2201 ^c	2881 ^c	3318 ^d	4593 ^d	5804 ^d	8402 ^d	
	Total	4759	5966	6508	8163	9105	12258	
Packaging	Plastic Film	4883 ^c	5287 ^e	6051 ^e	5901 ^e	6904 ^e	7990 ^e	8346 ^c
	(Agriculture Film)	873 ^c	862 ^c	961 ^c	939 ^c	1193 ^c	1572 ^c	1468 ^c
	Woven Products	2539 ^c	3013 ^e	4042 ^e	4772 ^e	5816 ^e	7120 ^e	
	Containers	1261 ^c	1487 ^e	1663 ^e	1731 ^e	2775 ^e	3431 ^e	
	Foam		1131 ^e	1381 ^e	1708 ^e	1871 ^e	2200 ^e	
	Total		10918 ^e	13136 ^e	14112 ^e	17335 ^e	20740 ^e	
Everyday Items		2718 ^c	3019 ^c	3710 ^c	4085 ^c	5442 ^c	6459 ^c	4584 ^c
Other			8117	9666	10780	12908	18853	
Total Production		23610 ^a	28020 ^a	33020 ^a	37140 ^a	44790 ^a	58310 ^a	54740 ^a
Export			8970 ^b	10350 ^b	11920 ^b	10110 ^b	14620 ^b	13040 ^b
Import			1430 ^b	1720 ^b	1590 ^b	1490 ^b	1840 ^b	1850 ^b

*Quantities without superscript were calculated. After Zhou²

inadequate to meet the demand. As a result, almost half of the primary material is imported. The total yearly imports of primary plastics in 2011 were 23Mt, amounting to just less than 50% of total demand. Given the Chinese Government's objective to keep the dependency on imports of any one commodity below 50%, the utilisation of recycled plastics can help reduce Chinese dependency on imports of primary plastics. The consultancy Pöyry, using data based on CBI China projections, predicts that the Chinese (including Hong Kong SAR) demand for recovered plastics could reach 29Mt by 2015⁴. There is detailed information available for PVC material flows in China²⁶.

Table 3 provides an overview of major applications of plastics in China. In 2009 strong domestic demand led to the rise in production of plastic products despite declining exports caused by the world financial crisis. The peak of production in 2010 can be explained by the rebound and recovery of market recession and macroeconomic control by the Chinese Government. In 2011 plastic production slightly declined from the 2010 level, resulting



Industrial plastic granules

from excessive growth in 2010. Production in the first quarter of 2012 showed a rising trend and indicated that the 2012 production would exceed the 2010 level, thereby maintaining this steady growth²⁷.

The data were obtained from a variety of data sources for cross-validation purposes. China's Statistical Database and China's Customs Statistics (CCS) are perceived as the most reliable amongst them. Trade in plastic profiles provided by IRR is the same as

that from CCS and total production of plastic products provided by IRR is also the same as that from China's Statistical Database. Plastic construction materials are underestimated because they only include profiles, pipes and ducts. This means that other types of plastic construction materials are subsumed under 'other' due to the absence of official sub-categories for plastic construction materials.

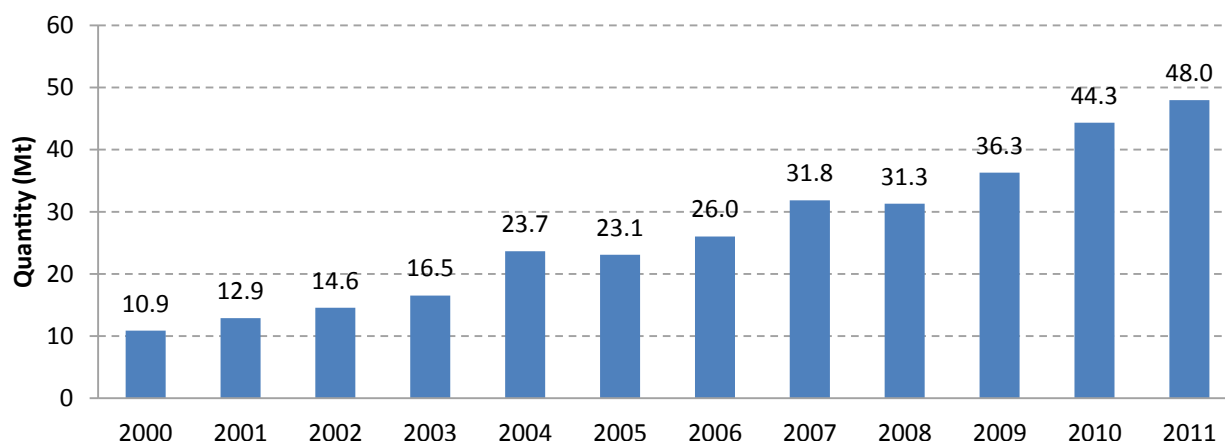

Figure 20. Demand for primary plastics in China. Data source: China Statistical Database²⁸. After Zhou²

6.2 Domestic generation of waste plastics

Plastic recycling in China is broken into three categories: industrial recycling, agricultural recycling and municipal (household) recycling. Industrial waste is characterised by relatively clean sources and consistent quality, recycled by producers themselves or by recovering companies. Agricultural waste achieves the lowest recycling rate, relying on manual recycling. Municipal plastics are mainly sorted by householders and sold to private col-

called 'three non-enterprises' (standing for: no rules for operation, no quality standards and no inspection, as translated from Chinese). Domestic waste plastics generation, including both industrial and post-consumer waste, increased rapidly, and in 2011 is almost twice that of imports. Waste plastics collected for recycling in China (domestically recovered plastics) can be either recycled or recovered as energy. Estimated quantities are

large-scale recovery bases.

Pronounced efforts were made in some pilot cities obtaining a 30% increase in recycling rates (from 40% to 70%). The Chinese Government published the notification of the establishment of a complete and advanced recycling system of waste commodities on 31 October 2011³². In addition the Chinese reprocessing industry is shifting towards greater

KEY FACT 12

There is insufficient understanding of the fate of plastic scrap after entering China and consequently its implications for local and global health and the environment. The 'Green Fence Operation' has rapidly changed the import and utilization situation.

lectors. In most cases, plastic waste entering the municipal waste stream is disposed of in landfill due to the lack of higher level technologies, sorting facilities and cheap disposal costs. However, waste PET and ABS have specific reclamation chains and relatively well developed infrastructure. Informal sector recycling (ISR) is also a wide-spread reality in China: typically, financially or otherwise socially disadvantaged people make a living by picking up recyclable wastes from local litter bins. There are recycling stores run by private operators, which sell recyclable waste to reprocessing companies including the so-

shown in **Figure 23** below. The quantities for 2006-2009 were calculated at an annual growth rate of 12.5%. In addition, the value of 15Mt in 2011 is an estimated figure (Ministry of Commerce in 'ChinaReplas 2012' conference).

Chinese local authorities have just started to transform the traditional collection system by introducing a chain of neighbourhood collection points. A number of recycling networks were built during the 'eleventh five-year plan', including 41,309 collection points, 226 sorting plants, 37 distribution markets and 91 regional

clustering and intensification. These developments signify the potential availability of considerably higher amounts of domestic plastic waste. However, such availability could only threaten the demand for imports when their technical recyclability is improved, for which there is not yet sufficient evidence.

6.3 Imports of plastic waste

The import of recyclable plastics is essential for supporting the Chinese manufacturing industry. Although the economic crisis disrupted the market in 2008 and 2009, it recovered rapidly in 2010. Between 2006 and 2011 plastic waste imports went up sharply from 5.86Mt to 8.38Mt respectively, an annual growth rate of 7.4%. However, the rate of increase in China's imports of waste plastics is slowing, from 21% annual growth rate in 2005

to 3.5% in 2009²⁷. **Figure 21** shows the value and amount of Chinese waste plastics imports. Although imports of waste plastics increased in amount during the economic downturn, albeit at a slower rate, the value of imports decreased significantly resulting from the collapse in raw material prices. Lower prices enabled a rise of 46.5% in imports of primary plastics and demand for waste plastics dropped. Consequently import values of waste

plastics rebounded rapidly in 2010. Prices of waste plastics also picked up after the downturn and fluctuated moderately, except for clear PET bottles. Average prices of waste plastics imports have continued to increase from \$549 a tonne in January 2012 to \$731 a tonne in March 2012³³.

World exports of waste plastics to China, including the Hong Kong SAR, were around 8400kt in 2011. The USA, Japan, Germany and UK represent more than half world exports of waste plastics to China and the Hong Kong SAR. The USA is the largest source country, accounting for 21% wt., followed by Japan (18% wt.), Germany (12% wt.) and the UK (9% wt.).

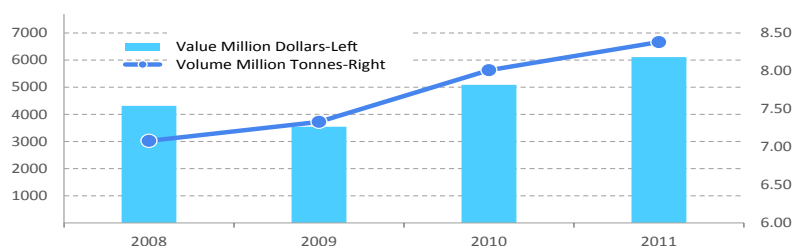

Figure 21. Chinese waste plastics imports, including the Hong Kong SAR. After Zhou². Data source: China Customs Statistics²⁷

Table 4. Sources of waste plastics imported to China in 2010. After Zhou². Data source: China Customs Statistics (CCS)²⁷

Country	Data Source: Chinese Customs		Data Source: UN Comtrade	
	Weight (kt)	% wt.	Weight (kt)	% wt.
Hong Kong SAR	1984	24.7	4069	50.8
Japan	737	9.2	769	9.6
Thailand	802	10.0	126	1.6
Germany	669	8.3	658	8.2
The Philippines	455	5.7	90	1.1
USA	426	5.3	942	11.8
Others	2972	36.9	1356	16.9
Total	8042	100	8010	100

Table 4 compares data published by the UN Comtrade with those of Chinese Customs. Although data for Japan and Germany are similar, the USA's direct exports of waste plastics to mainland China were much lower according to the Chinese Customs register; a similar discrepancy applies to the Hong Kong SAR. However, the total volume of waste plastics was similar. It is likely that waste was transhipped, both via the Hong Kong SAR and other countries, such as Thailand and the Philippines, which appear as significant suppliers of plastic waste to mainland China, according to the Chinese Customs. As the UK appears under 'Others' in **Table 4** the extent of transhipment via the Hong Kong SAR makes direct comparison of the two data sources difficult.

6.4 China: Production and demand for plastics

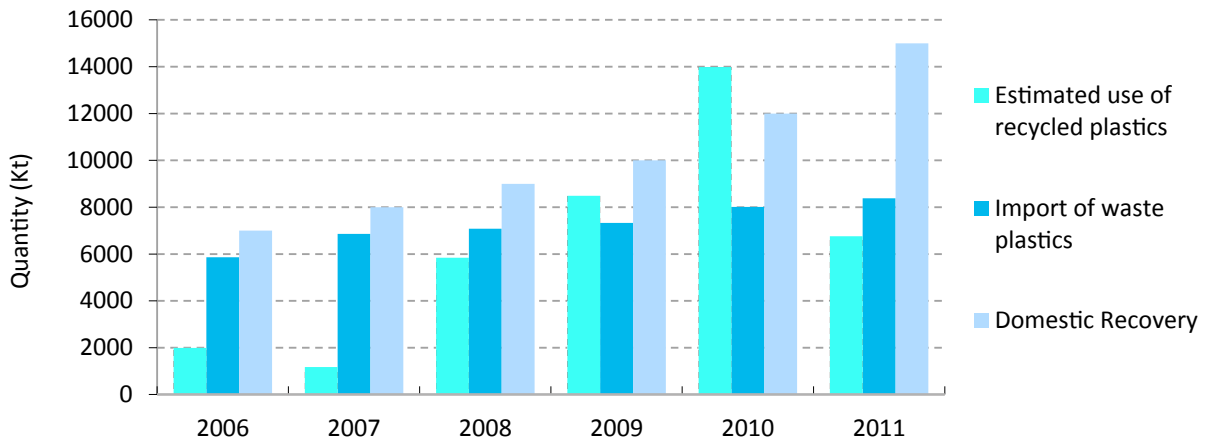

Figure 22. Estimated use of recycled plastics in China. 'Estimated use of recycled plastics' was calculated from the difference between the production of plastic products and the demand for primary plastics. Adapted from Zhou². Data source: China Customs Statistics (CCS)²⁷; except 'Estimated use of recycled plastics'.

Comparing **Figures 22 / 23** with **Table 4** the yearly production of plastic products is generally higher than the consumption of primary plastics, a difference that can be explained by the use of waste plastics. Domestic recovered plastics can be either recycled or recovered as energy, but there is no official disaggregated data on the balance between recycling and energy recovery. Officially, imported waste plastics are only allowed to be used for recycling purposes.

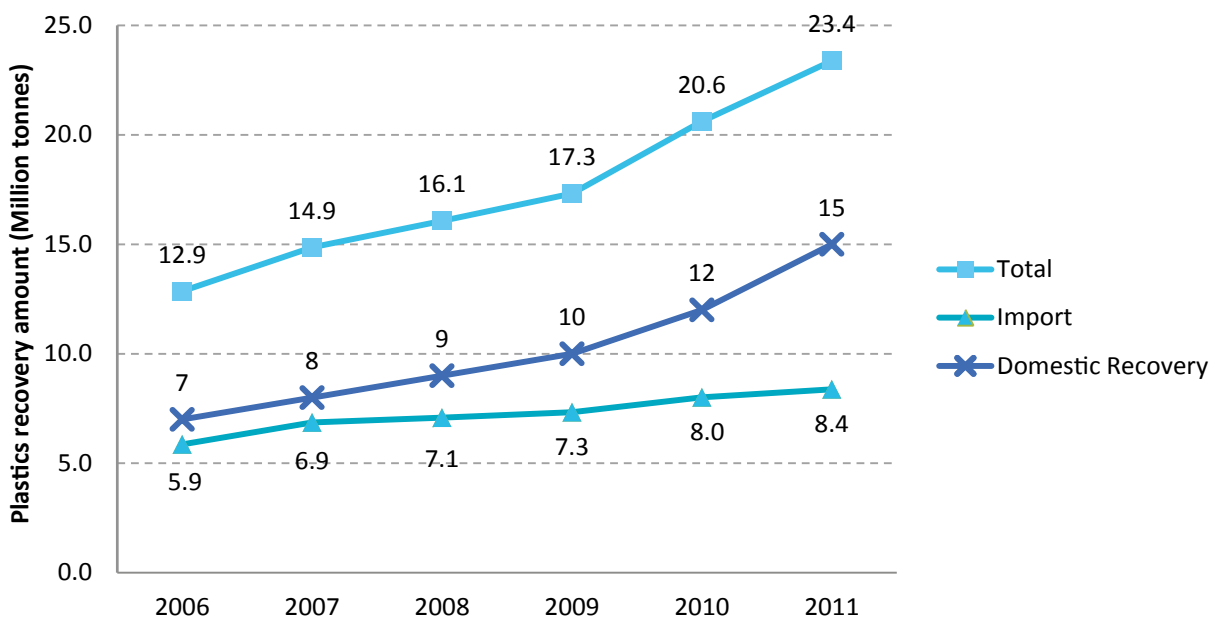

Figure 23. Total plastics recovery in China. After Zhou² (Import data source: China Customs Statistics (CCS) ²⁷)

The amount of recycled plastics used in China is as shown in **Figures 22 / 23**. This amount was calculated from the difference between the production of plastic products and the demand for primary plastics. It implies that data-sets for the use of recycled plastics and total recovered plastics are not mutually consistent. In 2006 and 2007 the use of recycled plastics was considerably lower (around 3-5 times) than imports of waste plastics which can be partly attributed to poor management within the waste plastics industry. In addition, Chinese importers tend to maintain some stock which enables them to negotiate to purchase waste plastics at lower market prices. This is reflected in the 2010 data. Imported waste plastics are not all incorporated into products due to impurities, water content and a range of other factors. The data in **Figure 22** also indicate that recycling of domestic waste plastics is very low, although domestic recovered plastics were almost twice the level of imports in 2011. Recycling of waste accounts for less than 50% wt. of total recovered plastics in China. It can be inferred that large quantities of domestic waste plastics are used for energy production EfW rather than recycled, although data to confirm this are not available.

including the 'three non-enterprises'. There is no guarantee of the quality of the products made from recycled materials by these companies. They produce large quantities of plastic products that do not have to meet quality specifications, such as plastic bags, disposable dishware and stationery items that are subsequently sold to retailers at low prices. During this period over 50% disposable and plastic bags in the Chinese market were unqualified products. It is commonly believed that after the manufacturing of waste plastics into finished products they are shipped back to Europe and the North American Free Trade Agreement (NAFTA) region. However, this is not the case. According to the seminar hosted by the Association of Postconsumer Plastic Recyclers most of the finished products containing imported plastic waste are consumed in China, as they are of lower cost and are mainly produced to meet domestic demand³⁵.

Zhou² conducted interviews with Chinese reprocessors to enquire whether they would source domestic waste plastics instead of imports. They responded that there was a "huge gap between domestic sources and foreign sources regarding quality" and therefore most of them would not

KEY FACT 13

Recycling of domestic waste plastics is still very low, although domestic recovered plastics were almost twice the imports in 2011. Indirect evidence suggests that the quality of some of the imported plastics scrap is higher than that obtained from domestic recycling collection schemes.

The 2009 report from WRAP was the most recent systematic effort to understand the Chinese recycling market. Some empirical and anecdotal information is also available from site visits to reprocessing facilities in China, such as from Moore Recycling (2008-9)^{10, 20}, and from Verde Recycling Solutions expertise³⁴. Valuable insights are available from web seminars organised by the Association of Postconsumer Plastic Recyclers (<http://plasticsrecycling.org/market-development/plastics-recycling-in-china->). Overall the evidence suggests that there are thousands of reprocessors in China. The job remains low-tech and entry requirements are very low: "Most recyclers [are] small labor intensive entrepreneurial operations using domestically fabricated equipment"²⁰. (Furthermore as a result of the crisis, "39% of plastic recycling businesses went out of business in China at the end of 2008")¹⁰.

Most local 'recycling stores' handling materials from collection for recycling within China are run by private operators who buy recyclable waste and sell it on to reprocessing companies,

consider sourcing waste plastics domestically. The prevailing perception of domestic waste plastics (those manufactured within China) is that the local manufacturers tend to add considerably higher amounts of additives, such as cheap fluorine surfactants, thus reducing their recyclability. Even though indisputable evidence on this important issue is not available, this view is consistent with older (1999) accounts of the situation in China. Therefore there is a clear differentiation between reprocessing operations based on their use or otherwise of imported waste plastics: "Two types of recyclers are distinguished: the ones using domestic waste plastics and the ones using imported waste plastics. The two types have different characteristics. Labour productivity of the importing recycler is higher due to better quality inputs, scale of operation as well as the higher capital intensity of production"³⁶. In addition many importers also re-sell waste plastics illegally to the '3-non-enterprises'. With improved market regulation in 2009, resale of imported waste plastics has been effectively reduced.

However, according to Verde Recycling Solutions, over the last decade, the size of many facilities has increased. Whereas most facilities use relatively more basic processing equipment than their equivalents in the West / North, technology levels are improving with increased use of e.g. optical sorters, bottle and flake, at several facilities in recent years. At such facilities, it would be unusual to operate untreated wastewater discharges or residues disposal by uncontrolled burning.

The Chinese central Government has introduced several new pieces of legislation in recent years related to plastics recycling, including regulations related to the operation of plastics recycling facilities and the import of plastic. The latter sets requirements for those wishing to import plastic waste (factory size, activities, etc.). For example, Import and environmental regulations that pertain to plastics recycling in China are:

- [1996]: Prohibit the importation of unprocessed scrap
- [2007]: Technical Specifications for Pollution Control during Collection and Recycle of Waste Plastics
- [2009]: AQSIQ regulation No. 119
- [2014]: the Green Fence Operation (GFO - see **Chapter 7**) includes governmental efforts to eliminate the illegal reprocessing sector within China by, for example, controlling the trade of import licences between licensed and unlicensed facilities³⁷.

As Verde Recycling Solutions has experienced on the ground by often site visits, over the last few years, in part linked to such legislation, the Chinese Government has been

closing smaller factories and not renewing SEPA waste import licenses where there was evidence that they do not operate to the required standard. The GFO (see **Section 7**) in particular focused also on clamping down on the trading of material between sites licensed to import plastic and third party recyclers. Such an ongoing effort and in particular effective local enforcement will be central to further improvements.

Plastic products made for the domestic market from virgin materials tend to be of low quality because manufacturers add many cheap fluorine surfactants and additives. Waste plastics from domestic collection are consequently of lower quality in comparison to imports, which reduces their value for recycling. It can be observed from **Figure 22** that use of recycled plastics exceeded imports in 2009 and 2010. The decline in 2011 is apparently due to the marked higher production in 2010. Despite the current seeming lag in technological capabilities in plastics manufacturing in comparison to the best world standards, the Chinese plastics manufacturing sector is anticipated to capitalise to assimilate the technological expertise created by the last two decades by foreign direct investment in the plastics manufacturing sector³⁸.

There are three key points to note here:

1. Recycling of domestic waste plastics is very low although domestic recovered plastics were almost twice the level of imports in 2011. Recycling of waste plastics only accounts for less than 50% of total recovered plastics in China. It can be inferred that large quantities of waste plastics recovered in China are recovered as energy rather than recycled although actual data are unavailable. These waste plastics are of lower value to



Figure 24. Photos from the Moore Recycling site visits in China in 2008-9. After Moore¹⁰

be recycled since producers tend to add many cheap fluorine surfactants or additives to plastic products, thus reducing their value for recycling.

2. Chinese importers are cautious of market fluctuations and tend to maintain some stock, which enables them to negotiate lower market prices while purchasing. This is also reflected in 2010 when domestic demand exceeded their expectations.
3. Imported waste plastics are not all incorporated into products due to impurities, water content etc.

According to a WRAP³⁹ survey of about 100 Chinese plastics reprocessors sourcing material from the UK, 80% of them manufacture the waste plastics into re-compounded pellets; '15% produced plastic fibre, 9% produced plastic film, 5% produced clean flake and 3% produced a product other than plastic film or fibre.' The intermediate products are then applied in non-food packaging (31%), agriculture (13%), textile (13%), construction (10%), automotive (1%) and others (21%), 11% of their end applications are unknown. However, end applications can only be analysed in a qualitative way as there are no reliable official data on applications of recycled plastics.

used in the packaging sector although other polymers are used to a small extent. There is a wide variety of recycled polymers used in construction market but rPVC accounts for the largest proportion. Others include vehicles, electrical appliances, everyday items etc. but it is difficult to identify the polymers used in these applications due to the diversity of products.

Imported waste PE comes mainly from packaging waste, and rHDPE and rLDPE account for the majority. rHDPE is applied in buckets, recycling bins, bottles, pipes etc., and rLDPE is mainly applied in films. In the north of China, rLDPE is often used in agricultural film, and in the south it may be used in various applications such as packaging and shoes. Recycling facilities of waste PE have an extensive distribution across the south, north and east China⁴⁰.

Imported waste PS comes mainly from toys, plastic cutlery, packaging, tapes etc., and most of rPS is applied in housewares such as hangers and coasters and construction materials such as flooring, insulation board and frames, or modified HIPS. Recycling facilities for waste PS are concentrated in southern China⁴⁰. Imported waste PVC mainly comes from containers, electrical and electronic appliances, pipes and

Table 5. Chinese plastics production and types of plastic products (thousand tonnes). Data sources: China Statistical Database^{28,a}; China Customs Statistics (CCS)^{27,b}; IRR^{29,c}; China Economic Information Network (CEIn)^{30,d}; Liao^{31,e}

Applications	Recycled Polymer	Typical Products
Packaging	PE	Bottles, buckets, bins, salvers, films
	PP	Bags, trays, recycling bins
Construction	PVC	Floors, pipes, panels, tubes, cables, window and door profiles, warning labels, binders
	PE	Fences, pipes
	PS	Flooring, insulation boards and frames
	PP	Pipes
Others	PET	Clothes, bedding, blankets
	PS	Hangers, pencil boxes
	PP	Automotive battery cases
	SAN, ABS, PC & etc.	Car parts, wood-plastic composites

Recycled plastics have a wide range of applications in China, and packaging and construction are the largest markets. **Table 5** shows main applications of recycled plastics in China based on data obtained from Zhou's interviews² and other reports⁴⁰. rPE and rPP are the major polymers

construction materials. Rigid PVC is in high demand for the construction market. Recycled plastics are used for 60%-70% of drainage pipes and 100% of sewage pipes¹⁵. Flexible PVC may be used in shoes etc. Most of the recycling facilities are located in southern China.

Imported waste PET comes mainly from the USA, Germany, Japan, Thailand, Mexico, Korea and Taiwan, and recycling facilities are concentrated in eastern China, especially Zhejiang and Jiangsu (Zhang, 2012). Remanufacturing of rPET has a vibrant and well-developed end market in China since PET bottles have been collected for recycling in China for decades. *“Most of recycled PET bottles are converted into fibre, primarily spun yarn. Some are used for non-woven fibres, filament fibres and fibrefill. A number of the amber and green bottles are converted back into non-food bottles, and some non-bottle PET is used in paints and wood varnishes”*⁴¹. rPET converted to fibre are mainly

manufactured into bedding, clothes, blankets etc.⁴⁰. Imported waste PP mainly comes from the mixed plastics stream and is remanufactured into hangers, pipes, trays, battery cases for cars etc.⁴⁰. Recycling of mixed plastics is much more complicated than for single variety products. PP, as the predominant polymer in mixed plastic waste is hand separated from other materials, mechanically recycled (ground, shredded, washed and melted) into pellets or flake. The remaining mixed plastics are often baled and sent to a secondary buyer and are subjected to a similar secondary separation by polymer and colour, ending up in products such as *“floor tiles, shoe soles, vinyl fabric, flower pots”* etc.⁴¹.



7. Crisis time: the Chinese Green Fence Operation

7.1 Chinese administration imposes stricter enforcement of waste imports rules

KEY FACT 14

Quality controls implemented by China's customs upset the entire global market having direct and rapidly felt upstream implications for the domestic reprocessing and waste management industries of the Western/Northern exporting countries. This demonstrates the fragility of the current global recycling system which operates in the absence of sufficient domestic demand, lack of advanced reprocessing capacity and absence of low contamination single polymer collection schemes. And the determination of the Chinese authorities to improve the overall sustainability of their use of secondary resources.



Figure 25. Waste plastic bales stockpiled

The so called 'Green Fence Operation' was an enhanced enforcement campaign implemented by Chinese customs from February to November 2013. They enforced legislation on the quality of imported waste-derived secondary raw materials and the functioning of the internal market. For example, in 2009 Chinese regulations allowed up to only 1.5% wt. of physical contamination. The Green Fence Operation instituted direct inspection of the content of containers, even inspecting the content of individual bales. This was an effort by the Chinese administration to reduce any illegal shipments, improve the quality of the imported waste-derived secondary raw materials, and minimise illegal trading within the country.

According to the President of the China Scrap Plastic Association, trading of import licences was forbidden and

imported plastics scrap "*must be delivered to the factory which is eligible to import, as stated on the import licence*"⁴. It has been reported^{37, 43} that shipments with banned items were targeted (WEEE, medical waste textiles, green waste, HDPE fishing nets, drums used for chemicals storage etc.) and also normal recyclable bales with considerable contamination with other materials (metals, paper, organics, other non-plastics), but not contamination with other types of resins. Targeted cases reported include: No 3-7 bales of bottles; mixed rigid plastics; material with high moisture content (above 12% on air-dry standard on a bale-by-bale basis); material with any type of organics contamination (e.g., unwashed used beverage bottles). High value items such as luxury goods hidden in secondary material shipments were also targeted³⁷.



KEY FACT 15

The current model of operation (predominantly export dependence on China) has become vital for the successful operation of Western/Northern municipal recycling systems. There are doubts about the system's resilience and overall sustainability.

7.2 Green Fence Operation impacts on the global waste plastics recycling market

There is evidence from all around that the world that the Green Fence Operation has affected export markets and impacted immediately upon the entire value chain of waste plastics. The effect on the exporting countries and businesses has been direct as reported in Resource Recycling⁴³: *"Inspections slow down port operations, shippers are now seeing rising demurrage costs as they pay ports to hold containers until they are inspected"*. Apparently many thousands of tonnes of all types of waste have been blocked. For example, more than 0.8Mt of illegal waste shipments have been intercepted, according to the customs agency, as reported in June 2013⁴⁵. Containers have been returned at a high cost (e.g. \$2,000 to the US). Large exporters in the USA started implementing more rigorous inspections in the countries of origin *"before the containers are delivered to the port for shipping"*. Reprocessors started rejecting bales with material that was acceptable before the onset of the crisis. Local recyclers in the USA and Canada had material piling up, with mixed plastic bales *"just not moving"*. This resulted in extra costs and efforts for the recycling companies who had to hire more personnel and everything slowed down.

According to representatives of various related companies and associations, German and Dutch have experienced reductions in export volumes; French companies, had difficulties in timely payments; and oversupply of plastics scrap was evident in the US⁴. Disruption of exports

impacted on the collection for recycling systems. There are indications that tipping fees for these materials have been increased in Canada, and in the US prices for some recovered materials declined by mid-April, which may have been a side-effect of the crisis: a price reduction of up 15% was reported⁴. In the UK, the Green Fence Operation was deemed as responsible for the shortfall in the availability of packaging export recovery notes (PERNs) which are part of the UK's waste packaging regulations. As a result, regulatory compliance for waste plastic producers has become much more expensive. It is currently debated *"whether there has been too much of a reliance in the overseas recycling of plastics"*⁴⁶. The plastic scrap exported to China from the UK experienced a drop from around 27Kt per month before the Green Fence Operation to an average of 17Kt per month during its 10 month operation³⁷, and experienced an abrupt fall in May to June 2013, but recovered from June to November 2013.

The potential negative effects on the domestic reprocessing capacity in the UK resulting from the overdependence on exports to China to meet recycling targets had also been criticised at the time of a previous financial crisis⁴⁷. At that time (2007) the absolute amounts exported were considerably lower (See **Figure 11**).

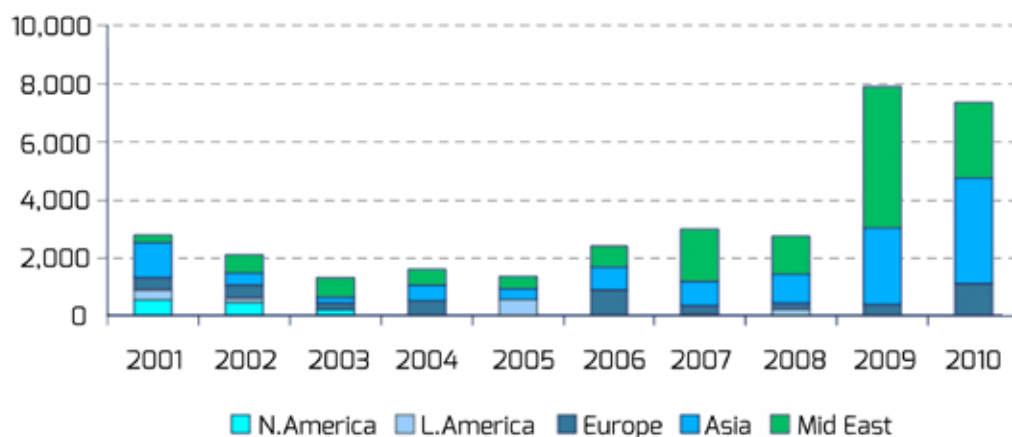

Figure 26. New PE reprocessing capacity built the last decade around the world. After Resource Recycling, as cited by Gwynn⁴⁸

Currently, it appears that domestic markets are not prepared to absorb the increased supply as they have become increasingly dependent on the Chinese market as their key outlet. There is not enough reprocessing capacity (indicatively, very limited new reprocessing PE capacity has been built in North America since 2001⁴⁸ – see **Figure 27**) and despite the fact that some MRFs operate well below their capacity they may not be equipped to produce materials suitable for the specifications required. Some argue that the problematic levels of contamination are a direct outcome of the co-mingled (UK) or singed stream (USA) collection of dry recyclables and of underinvestment in advanced sensor-based sorting (such as NIR; X-ray fluorescence; infrared spectroscopy; electrostatics) in MRFs. It could be argued that the dependence on exporting to China has hindered the development of domestic reprocessing and manufacturing in the Western/Northern countries and that it determined the mode of MSW collection (co-mingled) which results in streams of recyclables more difficult to process to high quality secondary raw materials.

There have been cases of traders which responded to the Green Fence Operation by increasingly selling their plastic scrap to countries that could accommodate for additional sorting and cleaning, serving as an intermediate processing step to meet the standards before selling to China⁴⁵. Countries mentioned are part of the ASEAN: Vietnam, Indonesia, and Malaysia. There is evidence that ASEAN countries had even before the current crisis been serving as a processing stop for plastics on route to the final destination of China (See **Section 4.6**). However, possibly the current processing capacity of ASEAN countries is too small to absorb all the re-directed flows, and strict import prohibitions often already exist for mixed recyclates (e.g. Malaysia). There is no

evidence that ASEAN countries are prepared in the long term to accept material of inferior quality that would have been rejected by China.

In a move that coincided with China's Green Fence Operation, the UK Government proposed increasing controls on export of waste from the UK (Transfrontier Shipment of Waste (Amendment) regulations 2013)⁴⁹. These overall EU and specific UK tighter controls are due to be implemented later in 2014. This development enjoys the support of the reprocessing sector as there are fears that shipments of poor quality of plastics and paper have been exported as 'green list' waste in an effort to avoid paying the considerable landfill tax that applies in the UK (currently at £80 per tonne of MSW). The increased enforcement cost is anticipated to result in increased export and import fees, but is thought necessary due to the considerable growth in waste exports volume in the recent years (see **Section 3.2** – and **Figure 11**). At the same time, according to Bradney³⁷ the UK exporters pay increased attention to the fate of the material after entering China, in an effort to ensure that *"recycling process is viable, safe and there is a low risk of pollution to the environment"*.

There may be additional reasons other than lack of reprocessing capacity that limit the development of domestic markets. For example, in the UK, a complex system of administrative certification is operated (Packaging Recovery Note - PRN obligation) which has been criticised as encouraging exports. A recent study revealed that of the 38% of the reprocessors that are not using waste plastics⁵⁰ for 37% it is due to reliability of supply; for 32% it is due to client specification; for 15% it is due to cost and for 15% it is due to difficulty in processing.



Hongkong - China border in Shenzhen city : Custom's office .
Photo BartłomiejMagierowski / Shutterstock.com

7.3 Possible long-term responses to the Green Fence Operation crisis?

The 2013 crisis generated considerable debate in the main exporting countries. Although the official enforcement of the Green Fence Operation had been completed in November 2013 there was the expectation that the new enforcement standards achieved might be maintained in the longer term. Many mid-term scenarios / solutions have been proposed by Plumer⁴² as possible responses to this new situation. These are summarised and further commented on below:

- **Quality vs. Quantity: Chinese manufacturers rely on the imported plastic scrap**, hence the restrictions will have to be relaxed after some months. There have been indications of a conflict of interest within the Chinese economy over the impact of the Green Fence initiative on business. The President of the China Scrap Plastic Association recently explained that the internal impact was that manufacturing companies relying on scrap or reclaimed plastics were often forced to replace them with more expensive raw materials, resulting in less price competitive products⁴.
- **Other import destinations could compensate for China.** Another proposed solution is to ship to intermediate countries e.g. ASEAN and have the material (manually) sorted and upgraded there. But these solutions seem highly speculative as there are no market needs or there are prohibitions in place (see **Section 6**).
- **Export countries will be able to produce less contaminated secondary materials (for export or not).** Assuming all was indeed exported for recycling and not illegal disposal, there may be ways to improve this. But current collection systems and reprocessing capacities within the export countries may not necessarily be capable of achieving this quality target in the short term. Notwithstanding this, the UK for example has recently developed significant capacity for plastics closed-loop recycling (4 plants). A specific plant in Dagenham, London, capable of processing up to 35Ktpa of waste plastic bottles – discarded PET soft drinks and water bottles and HDPE milk bottles are re-processed back into food-grade plastic⁵¹. The investment on local / regional collection and re-processing of high added value clean material capable of multiple material life-cycles may be the most effective way forward.
- **Export countries will recycle less resorting to more energy recovery** (direct or via SRF) or simply dispose of in landfills. However certain countries, for example many European Union Member States, impose a total ban or severe restrictions on landfill disposal along with strong relevant financial disincentives, some having already almost phased out landfill disposal of used plastics (See **Figure 1**).

8. Environmental and health considerations

8.1 General concerns for plastics recycling under poor environmental control capacity and law enforcement

The academic and technical solid waste management community has expressed concerns about the implication of global shipments of waste materials because sometimes the boundary line between export of recyclables and waste trafficking becomes unclear. As Kamuk and Hansen⁵² put it “*Global recycling – waste trafficking in disguise?*” Indeed, according to Bilitewski, the circular economy is not free from environmental and public health risks⁵³; and the globalised trade part of it means that that by transporting materials we are also transferring risks for their correct management. Velis and Brunner remind us⁵⁴. However, these risks do not only apply to wastes or secondary raw materials but also to all materials traded worldwide and to the inter-related off-shoring of production lines.

The local reprocessing / manufacturing enterprises have been criticised by the China Scrap Plastics Association for not adhering to environmental protection standards “*The waste water, waste gas, and rubbish at processing centres have created a serious environmental problem due to the insufficient implementation of environmental policy.*”⁵⁵. Examples of such situations on the ground were recently described in a documentary of the German televising ZDF, focusing in the over 5000 recycling facilities in the province of Shandong ⁵⁶.

There is a long list of potential environmental and health⁵⁷

concerns in relation to plastics manufacturing, use and improper disposal; these may be also poorly handled during the globalised flows of plastic scrap. The principal concerns are:

- **Potential excessive and uncontrolled use of additives during manufacturing:** often employed to compensate for the low quality grades used as raw materials: Indicatively, use of toxic plasticisers e.g. DEHP in PVC flooring⁵⁸; and⁵⁹ phthalates and adipates; polycarbonates components: bisphenol A (BPA)⁶⁰; poly-brominated flame retardants^{61, 62}, such as PDBA; heavy metals, fluorine surfactants; transition metals for oxo-degradable plastics) leading to human exposure and environmental dispersion. For example, in India, the non-mandatory guidelines (‘BIS’) regarding the use of phthalates has been criticised for not introducing limits for phthalates in products that may come in contact with children (toys and childcare goods)⁶³. The miscibility of plastics during recycling is a limiting factor – for example, on casings of LCD screens⁶⁴, often resulting in need for compatibilisers.
- **Health and safety risk for workers reprocessing plastic scrap,** which can be exacerbated if the

KEY FACT 16

The important concerns expressed in relation to environment and health aspects of the international plastic scrap trade have not been systematically explored sufficiently to be verified or dismissed.

appropriate preventive procedures are not in place. Indicatively during re-melting for plastics manufacturing volatile organic compounds (VOCs) are emitted⁶⁵, from "... compounds originating from polymer degradation, the compounds originating from the plastic additives ... and likely originating from contaminant inseparable polyvinyl chloride (PVC), food residues, cleaning agents, degreasers, and so on were detected from the waste plastic. Thus, melting waste plastics, as is conducted in recycling facilities, might generate larger amounts of potentially toxic compounds than producing virgin plastics." In the case of burnt plastics the fumes contain hydrogen cyanide, hydrogen chloride and isocyanate; and where BFRs are used the environmental risk is greater due to the burning of the retardant⁶⁶. Because "During the plastic manufacturing, toxic products can enter the working environment due to the plastic heating" screening procedures that perform environmental analysis and risk assessment are necessary to "define if workers' risk level is acceptable or not"⁶⁷. Exposure of workers to styrene during plastics manufacturing⁶⁸ revealed

correlation between the duration of styrene exposure and ventilatory function parameters, also between the duration of styrene exposure and some detectable chromosomal aberrations."

- **Local / regional environmental degradation by reprocessing** under poor emission control, and unsound disposal of rejects / residues.
- **Health and safety of informal sector recyclers**, salvaging secondary plastic.
- **Uncontrolled or unsuitable disposal of the plastic scrap in the destination countries** (landfill disposal, dumping, burning, energy recovery under lower environmental standards, littering), which is prohibited by many export / import national laws.
- **Global environmental implications** (e.g. CO₂ and other emissions) of using highly non-biogenic non-renewable energy sources; and trans-boundary container shipment: which may be beneficial by utilising the free container vessel capacity when returning to countries of manufacturing, such as China.

KEY FACT 17

The global trade of recyclables is fuelling real local industrial demand. But, at best it also transports potentially polluting compounds and the risk and liability to manage these reliably. Waste trafficking is the other end of the spectrum of waste trans-boundary movement.

International collaboration and checks at both export and import points are necessary to guarantee free trade of valuable waste-derived commodities, without endangering public and occupational health. Weak links in this chain should be identified and eliminated.

"statistically significant difference between the exposed and the control groups as regard the blood styrene level, urinary mandelic acid level, β2 microglobulin in urine, and chromosomal study. The study also showed a statistically significant

- **Impeding the development of domestic resource efficient solutions**, by dependence on export, which could maximise resource recovery under environmentally sound conditions.

- **Pathway of least environmental standards** followed in selecting exporting destinations (similarly to, e.g., WEEE).
- **Environmental dispersion of problematic chemical compounds**, such as persistent organic pollutants (POPs) by recycling instead of destruction and containment via suitable high temperature thermal recovery (e.g., via SRF in cement kilns).

The Green Fence Operation crisis (**Chapter 7**) highlighted the issue of illegal shipments of waste (trafficking). It seems that some of the material has been traded in violation of the international conventions or national laws, both for exports and imports. ISWA has taken clear action in highlighting relevant challenges in its White Paper on

waste trafficking⁶⁹. BIR has been encouraging the European Commission to facilitate clarity by introducing a clearer distinction between 'illegal shipments' and 'shipments in violation of the EU regulation', the latter "may be due to missing papers or incomplete or inaccurate paperwork or administrative mistakes"⁴. Key aspects of the risks and its improved management are: (i) the efforts of the Chinese administration via the Green Fence Operation to improve the quality of the imported material which could then be increasingly suitable for high quality reprocessing operations; (ii) the abundance within China of the "three non-enterprises" and the Chinese attempts to restrict them; and (iii) the increased awareness and recently initiated efforts of the exporters to ensure the environmentally sound fate of the material after entering China.



Figure 27. Recovering plastics from a dump, Kathmandu, Nepal, 2013. Photo - De Visu / Shutterstock.com

8.2 A path of least resistance?

KEY FACT 18

It has been argued that a least beneficial environmental impact path is followed in global waste and secondary raw materials trans-shipment.

Some authors¹ argue that insights about global recycling networks can be gained if examined through the frameworks of global value chains and global production networks. In doing this, they do not sufficiently differentiate between legal trade and trafficking. Having applied these explanatory frameworks to the cases of waste clothing and ships, they put forward a series of hypotheses, suggesting that poor environmental governance and cheap labour costs are the conditions that enable the recycling, even when pollution is a side-effect of recovery operations: *"Since ships contain hazardous materials, it is the laxer environmental regulation in Bangladesh (and India and Pakistan) that enables their transformation from uneconomic vessels into secondary resources"*. The trading of hazardous materials, as exemplified in *"patterns of trade in electronic waste"*, suggests the destinations for reprocessing are selected because they are 'pollution heavens'. They also conclude that globally recycled wastes often pass through intermediary places chosen for their infrastructural capacities and lax institutional settings and/or enforcement: *"regulatory regimes of different locations and their articulations are vital to making new commodities from old."* And: *"the paths of discarded clothes are shaped by the different taxes, values, and demands, depending on whether they are processed as clothes for re-use or fibres for reweaving in India."*

So a direct link is proposed between Western consumption patterns and the small-scale low-tech reprocessing enterprises in South Asia. However, it could be argued that such hypotheses do not just pertain to trade /exports of waste but to all tradable goods. There are very few theoretical model investigations on the international trade of waste plastics. D'Amato et al.⁷⁰ have explored theoretical export models based on economic policy and institutional aspects and validated those against real data of waste PE trade. They concluded that exporting prices and legal rights enforcement seem not to affect export flows but relying on landfilling does so. They argue that there is a negative correlation between amount of exported waste and the wages in the importing countries (i.e. the lower the wages in a country importing wastes for reprocessing the more waste it is importing). Hence it seems that the trade flows

always along a trail of '*least resistance*': The case of the Hong Kong SAR and China (See **Section 4.3**) and the role of ASEAN countries in the case of waste plastics (See **Section 4.6**) and Green Fence Operation (See **Chapter 7**) could also be case studies supporting such hypotheses. Ultimately all these flows depend on the quality of the used materials the affluent Western / North countries are exporting in the first place.

Within China, reprocessing of the imported plastics waste is performed by a wide variety of companies. There are concerns that considerable quantities are processed in *"primitive, family-owned workshops with no facilities to treat waste water before it flows into local rivers"*, according to Ford⁴⁵. Before the Green Fence Operation, a typical level of contamination for USA exported material could have been at 20% wt., according to estimates by a technical consultant to the Washington-based Association of Postconsumer Plastic Recyclers, as reported by Ford⁴⁵. This contamination after being sorted out would then be *"buried or burned, further degrading China's environment"*. However, there are continued efforts by the Chinese government, intensified during the GFO, to change this and eliminate these polluting unlicensed unregulated facilities.



Figure 28. "A Chinese woman holds her baby as she strips labels from plastic soda bottles so they can be recycled. If she works hard, she can earn about \$15 a day". Copyright: Peter Ford/The Christian Science Monitor. After Ford⁴⁵.

8.3 Implications of the high level of virgin material substitution required for environmental benefits from plastics recycling

Recent comprehensive data on life-cycle assessment (LCA) for plastic recycling, indicate that it can be preferred over energy recovery, only if the substitution rate of virgin plastics is very high. According to Rajendran et al.⁷¹, who focused on “*the comparison of LCA results between individual and aggregated impacts and integration of performance of recycled plastics in LCA*” regarding “*LCA studies on mechanical recycling and energy recovery scenarios*”, concluding that “*recycling was the preferred option if it could replace a minimum of 70–80% of virgin plastics*”.

Lazarevic et al.⁷² comparatively examined end-of-life options for post-consumer plastics, in a European context, state that some of the studies have

waste hierarchy should be applied to the management of waste plastics on every occasion. Specifically: “*However, it has been shown that the virgin material substitution ratio and amount of organic contamination could lead to recycling showing lower environmental benefits than other treatment options such as incineration with energy recovery*”.

Astrup et al.⁷³ examined major greenhouse gas (GHG) emissions associated with plastic waste recycling, ignoring any extra global warming contributions associated with waste plastics reprocessing to quality equivalent to virgin material. From the three alternative scenarios examined (recycling of clean, single-type plastic, substituting virgin material; recycling of mixed/contaminated plastic; and use of plas-

tion for medium quality plastic scrap was considered (“*medium-quality granulates dominated by compatible plastic types but not sufficiently clean to allow for production of high-quality plastic products*”) concluding that “*Recycling of plastic waste for substitution of other materials such as wood provided no savings with respect to global warming*.”

Hence, the exact plastic scrap grade and the manufacturing conditions should be taken into account if environmental benefits from international plastics recycling are to materialise. Further investigation is necessary to accurately quantify the environmental implications of the global used plastics trade. Concerns for the non-optimal environmental benefits resulting from recycling under poor manufacturing and environmental protection conditions may encourage the development of local / regional supply chains for used plastics in the affluent Western/Northern countries.

Such supply chains could focus on waste plastics of very low contamination recovered in localized / regional reprocessing facilities and finally used as secondary raw material in manufacturing plants within the plastic consuming countries, ideally using closed-loop recycling as is the case with bottle-to-bottle recycling. Effective collection for recycling combined with advanced separation methods (e.g. sensor based sorting) are also needed for the bulk of post-consumer plastics that will not be able to be collected as separate, single polymer flows. However, such propositions would benefit from further investigation.



Industrial plastic granules

overly relied on ambitious assumptions relating to the virgin material substitution ratio and level of contamination, factors which “*[...] can have a significant influence upon the results of these studies*”. According to them, because the uncertainties involved are high it cannot be supported that the

tic waste as fuel in industrial processes replacing coal or oil), they concluded that “*[...] substitution of virgin plastic should be preferred. If this is not viable due to a mixture of different plastic types and/or contamination, the plastic should be used for energy utilization*.” For the case of wood substit-

9. Challenges for trans-boundary trade

KEY FACT 19

The market can be easily disrupted because it depends on many industrial sectors, the heavily regulated waste sector and the oligopsony of China.

The international trade in used plastic is a complex operation (see Key market factors - **Section 3.4**) which can be threatened by many factors. These include:

- Prohibitions relating to export, transfer, and import of waste / secondary raw materials. For example, EU legislation prohibits the export for disposal. Certain countries (Malaysia, India, Middle East, China for mixed plastics) have recently introduced laws banning the imports of certain loads of plastic scrap, based on its mixed or contaminated nature.
- Oligopsony conditions (China main global importer) create conditions for easy market disruption, as occurred during the price fall for secondary raw materials during the 2008-9 financial crisis (Quarter 4 of 2008) and the 2013 Green Fence Operation (see **Chapter 8**).
- Complex logistics, often based on 'reverse haulage', requiring specialised services of forwarders (stuffing, distribution, customs clearance).
- Inconsistency of plastic container loads sought by shipping lines resulting in budgeting difficulties and uncertainty.
- Susceptibility to virgin raw materials and fuel cost fluctuations.
- Competition for quality secondary raw materials (e.g. clean single resins, such as food-contact suitable PET which is also locally increasingly recovered in Northern/Western countries bottle to bottle schemes).
- Difficulty to guarantee quality of waste-derived materials shipped from the export countries.
- Material quality information asymmetry between buyers and sellers – lack of transparency at various points of supply chain (e.g. info on reprocessing facilities licencing, auditing etc.).



10. Future outlook - trends - questions

10.1 China is changing

As the biggest importer worldwide, China is of obvious importance. Experts such as Verde Recycling Solutions, Moore Recycling, and Resource Recycling have speculated based on existing trends:

- Manufacturing is likely to remain strong in China, but may change as result of the growing domestic demand and improved GDP.
- China will focus more on importing quality secondary materials and manufacturing products of higher added value, eliminating unlicensed reprocessing facilities, meeting environmental specifications, and occupational health and safety conditions.
- Self-sufficiency from domestic recycling schemes will increase.
- But investment by China in raw material production elsewhere, such as in Asia and Africa, and an increase of westbound freight rates may change the scene. Similarly, some of the manufacturing may be returned to the Western/ Northern countries – as was the case of a plastic toy assembly line moving from China to the USA⁷⁴.
- The US National Association of manufacturers believes that the challenge posed to the US has peaked and the China's competitive advantage is in decline.
- But local demand may be high enough so that strong need for import persists.
- Governmental support to imports is likely to continue due to direct and indirect benefits (employment, preserving raw material reserves, tax revenues).
- Nearby recycling markets may emerge: India, Malaysia, Indonesia and Vietnam.



Modern drinks production plant in China

10.2 Innovation – source of solutions and new challenges

Innovation will keep shifting the possibilities to recover value from waste plastics. Such changes can have both positive and negative implications. Past innovation examples are: light-weighting, composites, food-contact applications (from PET to HDPE to thermoformed PET in 10 years). Recent experience shows that **improved collection logistics** are becoming a reality. For example, in the USA 63% of Americans have their plastics collected weekly at the kerbside, and 70% will soon be on single-stream (or co-mingled) programmes (access to single stream improvement: 2005 29% of population; 2010 64%). Predictions support that more multi-family homes will be served, more small businesses, services to public areas and events. However, there is on-going debate over optimal collection methods⁷.

Additional and more technically advanced **MRFs** could be deployed (for example, now ca. 600 in the US). Adaptation to changes in feedstock and exploring processing for non-bottle mixed-rigid plastics (tubs, lids, buckets) and PET thermoformed packaging (e.g. projects such as the decision by the Canadian retailers resulting in the addition of thermoformed PET in kerbside collections) is needed. More advanced sensor-based sorting system with ability to handle entire bottles or flakes. Plastics-to-oil innovations could be an additional solution for the **unrecyclable fraction** (motor oil bottles, plastic film in recovered paper bales, MRF sweepings, some forms of agricultural plastics, some composites), with companies already working in this sector: Agilyx, Vadyxx, JBI with RockTenn.

Oxo-degradable and **compostable** plastics will have consequences for **recyclability**: (innovation side-effects): Oxo contain a pro-oxidant additive containing transition metal ions of cobalt, iron, manganese and/or nickel, additive used at 1-4% of the loading making it easy to manufacture the bag, bottle etc. Oxo-degradable plastics break apart when thermally stressed. There is disagreement on their performance: suppliers claim they are degradable while many others argue they are not. Concerns have been expressed about harming existing recycling schemes. For example, the State of California sued three water bottle manufacturers over their claims.

Bio-based polymers is another rapidly increasingly used family of materials where innovation occurs delivering new solutions, whereas generating complex engineering and policy dilemmas, described elsewhere^{75,76}. Their co-existence

with fossil-based plastics will inevitably result in increased systems complexity. Concerns have been expressed that they could disrupt the recycling of established fossil-based plastics⁷⁷: for example that of PET, often targeted for bottle-to-bottle (closed-loop) recycling⁷⁸, but there is no unanimity on such negative effects: they are dismissed by the biopolymer proponents.

Eco-design and green chemistry innovation is hoped to deliver improvements on the material properties and improve the inherent potential recyclability of plastic materials in the future. Discussing the case of polypropylene (PP) recycling⁷⁹, maintains that most plastic polymers are potentially recyclable. But, in most of the cases of used plastics still many *“recycled plastic items are considered to be useful only for low-value applications. It is common for quality and appearance to degrade with each reprocessing cycle.”* However, the technical reprocessing challenges are able to be addressed. In the case of PP restabilisation is needed, i.e. replenishing of the stabilisers (additives) needed to prevent its photo-oxidative degradation during use and the thermal-oxidative degradation during re-melting.

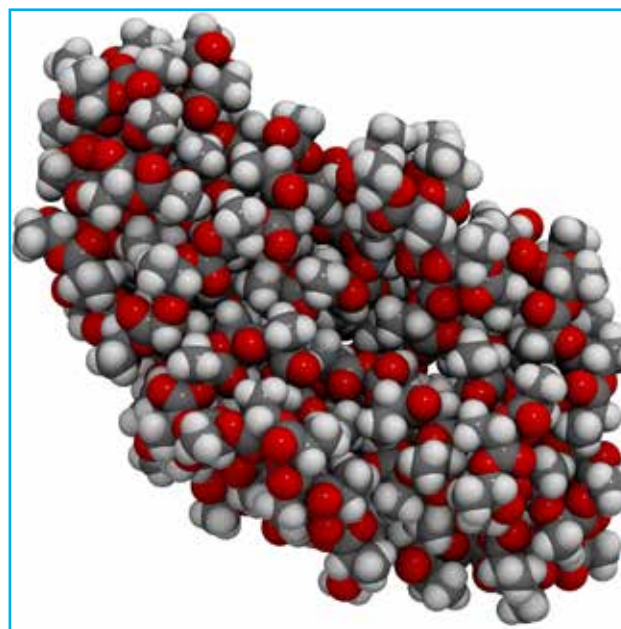

Polylactic acid (PLA) bioplastic molecule, chemical structure. PLA bioplastic is an alternative for a number of petroleum-based plastics.

10.3 Evolving policies

Policies regarding plastic use will also evolve, with direct impacts on the globalised market. Existing examples of recent changes and trends are: ban on retailer plastic bags (many USA localities, state-wide or local communities, enacted policies on this - however the plastics industry disputes the necessity, effectiveness and warns for unintended consequences for targeting plastics bags); ban on Bisphenol A (BPA)-containing packaging. In September 2010 Canada declared BPA as a toxic substance. BPA use in baby bottles has been banned in the EU, Canada, and USA. The same applies to certain PDBAs. The scientific community has been arguing persistently for an increased focus on environmental, public health and occupational health and safety aspects of plastics recycling, similar to the focus on WEEE handling.

There is an inevitable trade-off between quality and quantity, with current trends putting higher emphasis on initial collection rather than actual value recovery. Higher targets for collection for recycling may mean that higher amounts will be available to extract value from, both locally and globally, creating additional pressure (innovation and regional capacity) for recovery solutions. Strong emphasis should be given on the responsibility of the exporting countries to effective management of exports and subsequent supply chain, including understanding the controls (or lack thereof) at the destination country, checking facility licenses to ensure the factory holds the correct permissions and ideally having them been audited. Efforts focused on the quality and maximising the sustainability impact of the recycling process should eventually emerge⁵⁴.



11. Key facts summary

No.	Key fact
1	Waste plastics traded internationally are a small fraction of annual new plastic production (<5% wt.).
2	Pre-consumer (industrial) plastic scrap, a by-product of industrial activities, is recycled as feedstock to a very high extent already (e.g. see the UK case study). The big challenges are with the post-consumer plastics, and especially those arising from mixed ('co-mingled' (UK)/ 'single stream' (USA)) collection, sent for mechanical recycling. Plastic waste present in residual waste (ideally limited to the non-sustainably recyclable part of waste) in most of the cases can potentially be directed to energy recovery via production of quality assured solid recovered fuel (SRF) or via energy from waste combustion plants (EfW) producing combined heat and power (CHP).
3	Waste plastics are traded in a globalised supply chain and market.
4	Many industrial sectors are involved: traditional waste management, informal sector collectors, repro-processors, transporters/forwarders, local and multi-national manufacturers.
5	The current mode of operation balances the trade deficit of the Northern/Western countries, utilises the otherwise empty containers (reverse haulage) and supplies Chinese manufacturing industry with necessary affordable secondary raw materials.
6	A steady market increase is in direct relationship with primary plastics production. Decreases in the prices of primary plastics directly affect the prices and trade volume of secondary plastics.
7	China including the Hong Kong SAR is the key player in the global market for plastic waste, being by far the biggest importer (49% of financial transactions for imports – 56% wt.).
8	Europe, the biggest exporter worldwide of waste plastic intended for recycling, depends largely on China: 87% wt. is exported to China either directly or via the Hong Kong SAR. The exported quantity is 46% of the overall quantity collected for recycling, and 12% of the entire plastic waste arisings in Europe. In contrast, Europe exports only 1.2% of its primary plastics products to China. High dependencies on exports to China also hold for Japan and the USA.
9	The Hong Kong SAR serves almost exclusively as an alternative entry point for the Chinese market – it used to be considered a more lax entry point.
10	ASEAN countries (mainly Vietnam, Malaysia and Indonesia) export to China, possibly re-exporting repro-cessed imports and exporting domestically collected plastic scrap.
11	There is insufficient understanding of the fate of the plastic scrap after entering China and consequent-ly implications for local and global health and environment. The 'Green Fence Operation' has rapidly changed the import and utilization situation.
12	Despite regulatory and enforcement efforts in China there is still considerable reprocessing and trade that is not sufficiently managed ('three non-enterprises', implying: (i) no rules for operation (ii) no quality standards and (iii) no inspection).

- 13** Recycling of domestic waste plastics is still very low, although domestic recovered plastics were almost twice the imports in 2011. Indirect evidence suggests that the quality of some of the imported plastics scrap is higher than that obtained from domestic recycling collection schemes.
- 14** Quality controls implemented by China's customs upset the entire global market having direct and rapidly felt upstream implications for the domestic reprocessing and waste management industries of the Western/Northern exporting countries. This demonstrates the fragility of the current global recycling system which operates in the absence of sufficient domestic demand, lack of advanced reprocessing capacity and absence of low contamination single polymer collection schemes. And the determination of the Chinese authorities to improve the overall sustainability of their use of secondary resources.
- 15** The current model of operation (predominantly export dependence on China) has become vital for the successful operation of Western/Northern municipal recycling systems. There are doubts about the system's resilience and overall sustainability.
- 16** The important concerns expressed in relation to environment and health aspects of international plastic scrap trade have not been systematically explored sufficiently to be verified or dismissed.
- 17** The global trade of recyclables is fuelling real local industrial demand. But, at best it also transports potentially polluting compounds and the risk and liability to manage these reliably. Waste trafficking is the other end of the spectrum of waste trans-boundary movement. International collaboration and checks at both export and import points are necessary to guarantee free trade of valuable waste-derived commodities, without endangering public and occupational health. Weak links in this chain should be identified and eliminated.
- 18** It has been argued that a least beneficial environmental impact path is followed in global waste and secondary raw materials trans-shipment.
- 19** The market can be easily disrupted because it depends on many industrial sectors, the heavily regulated waste sector and the oligopsony of China.

References

1. Crang, M.; Hughes, A.; Gregson, N.; Norris, L.; Ahamed, F. (2013). Rethinking governance and value in commodity chains through global recycling networks. *Transactions of the Institute of British Geographers* 38, (1), 12-24.
2. Zhou, S. (2012). UK to China Flows of Waste Plastics: a Critical Evaluation. MSc, Imperial College London, London.
3. Plastics Europe, (2013). *Plastics - the facts 2013. Analysis of European plastics production, demand and waste data for 2012*; p37.
4. Bureau of International Recycling (BIR), (2013). "Incredible" consumption outlook for recovered plastics; 05 June 2013 p2. See: <http://www.bir.org/news-press/latest-news/bir-shanghai-plastics-incredible-consumption-outlook-for-recovered-plastics/>
5. Bureau of International Recycling (BIR), 2013; *The Industry - Plastics - Recycling facts*; 05 June 2013 p2 See: <http://www.bir.org/industry/plastics/>
6. UN Comtrade, (2013). United Nations Commodity Trade Statistics Database. United Nations.
7. WRAP (2009) *Choosing the right recycling collection system*; June 2009, p 8 See: <http://www.wrap.org.uk/sites/files/wrap/Choosing%20the%20right%20recycling%20collection%20system.pdf>
8. Morgan, S. (2012). *UK household plastics collection survey 2012*; RECOUP: Peterborough, UK, 2012, p 40.
9. Wong, C. (2010). *A study of plastic recycling supply chain* University of Hull, Business School and Logistics Institute: Hull, UK, October 2010, p68.
10. Moore, P. (2011). *Plastics recycling in China: the truth behind the myths*; Washington, See: <http://www.plasticsrecycling.org/market-development/plastics-recycling-in-china-> Accessed on: 10 July 2012.
11. Letsrecycle.com, (2012). Plastics Prices Archive. See: <http://www.letsrecycle.com/prices/plastics/plastics-prices-archive> Accessed on: 6 August 2012
12. Resource Recycling, (2013). Exports edge up in February. See: <http://resource-recycling.com/node/3744> Accessed on: 15 May 2013
13. WRAP, (2012). *Material Pricing Report*; See: http://www2.wrap.org.uk/recycling_industry/market_information/materials_pricing_reports/index.html Accessed on: 8 June 2012
14. HM Revenue & Customs, (2012). Statistics.
15. WRAP, (2011). *The Chinese markets for recovered paper and plastics – an update*; See: <http://www2.wrap.org.uk/document.rm?id=10601> Accessed on: 7 June 2012
16. Institute of Scrap Recycling Industries (ISRI), (2012). *The ISRI scrap yearbook 2012*; ISRI: Washington, DC, USA, p49. See: <http://www.isri.org/CMDownload.aspx?ContentKey=41c2f107-0576-4a61-a0aa-078cab920e84&ContentItemKey=f08c8afb-2927-4820-84bd-19eeada22839> Accessed on: 15 June 2014
17. Oon, A. C. L. (Unpublished). *Global waste plastics recycling markets: A South East Asia outlook*; University of Leeds - School of Civil Engineering: May 2013, p27.
18. The Council for PET Bottle Recycling (CBPR), (2012). *PET bottle recycling in Japan*; See: <http://www.petbottle-rec.jp/english/reports.html> Accessed on: 18 June 2012
19. The Council for PET Bottle Recycling (CBPR), (2013). *Case study for multi-stakeholder partnerships. From wastes to valuable resources: PET bottle recycling in Japan.*; Japan, 19 March 2013, p12. See: http://www.petbottle-rec.jp/topics/pdf/20130318_Presentation.pdf Accessed on: 30 May 2013

20. Moore Recycling Associates, (2012). *2010 National post-consumer non-bottle rigid plastic recycling report*; American Chemistry Council: January 2012, p14. See: <http://plastics.americanchemistry.com/Education-Resources/Publications/2010-National-Report-on-Post-Consumer-Non-Bottle-Rigid-Plastic-Recycling.pdf> Accessed on: 10 August 2012
21. Powell, J. (Undated). *Plastics: the big picture*; Resource Recycling: Portland, Oregon, Canada, See: www.resource-recycling.com
22. Kuczenski, B.; Geyer, R. (2010). Material flow analysis of polyethylene terephthalate in the US, 1996-2007. *Resources, Conservation and Recycling* 54, (12), 1161-1169.
23. Jiang, Y. X.; Jiang, M. (2013). Plastics: The discovery in the world and development in china. In Vol. 750-752, pp 811-815.
24. Liao, Z. P. (2011). China's plastics industry (In Chinese). *China Plastics* 25, (5), 1-10.
25. Liao, Z. P. (2010). Analysis of supply and demand, and development potential of waste plastics (In Chinese). *Resource Recycling*, (01), 10-13.
26. Zhou, Y.; Yang, N.; Hu, S. (2013). Industrial metabolism of PVC in China: A dynamic material flow analysis. *Resources, Conservation and Recycling* 73, 33-40.
27. China Customs Statistics (CCS), (2012). Customs Statistics.
28. China Statistical Database, (2012). Statistics Data. [Online]
29. IRR, (2012). *Petrochemicals* (In Chinese) See: <http://jinchukou.chyxx.com/shiyouhuagong> Accessed on: 13 June 2012.
30. China Economic Information Network (CEIn), (2012). China Economic Information Network (In Chinese).
31. Liao, Z. P. (2010). China's plastics industry (2009) (In Chinese). *World Plastics* 28 (4), 16-35.
32. Wang, X. B. (2012). The collection system: construction of renewable resources in China in recent years (In Chinese). *China Scrap Plastics*, (05), 12-14.
33. Lv, X. S. (2012). Comprehensive account of Chinese scrap plastics importation from January to March (In Chinese). *China Scrap Plastics*, (06), 9-11.
34. Jefferson, M. (2010). *Recycling in China*; Verde Recycling Solutions Sprl: See: <http://www.grontpunkt.no/files/dmfile/China-GreenDotNorway1.pdf> Accessed on: 10 May 2013.
35. Nina, Y. (2011). Myth or fact: waste export to China. *Plastic News*, (1st February 2011).
36. van Beukering, P. (1999). *Plastics Recycling in China an international life cycle approach (Summary Translated from Chinese)*; IVM Report number W99/05; Institute for Environmental Studies (IVM); Chinese Academy of International Trade and Economic Co-operation (CAITEC); Policy Research Centre for Environment and Economy (PRCEE): May 1999, See: <https://www.elaw.org/system/files/Plastics.Recycling.in.China.pdf>
37. Bradney, L. (2014). The Green Fence. *CIWM - The journal for waste & resource management professionals*, (April 2014), 52-53.
38. Toensmeier, P. (2012). China's plastics industry: A world of potential. *Plast. Eng.* 68, (9), 20-25.
39. WRAP, (2010). *China market sentiment survey*; See: <http://www.wrap.org.uk/content/report-china-market-sentiment-survey> Accessed on: 29 June 2012.
40. Zhang, B., (2012). A Research on Recycled Plastics' Environmental Economy Value. In *ChinaReplas 2012 (Spring)*: Shanghai.

41. Moore, P. (2012). *Film, PET and mixed plastic recycling in China*; See: http://www.moorerecycling.com/ChinaReport_Final.pdf Accessed on: 11 July 2012
42. Plumer, B. (2013). China doesn't even want to buy our garbage anymore. See: <http://www.washingtonpost.com/blogs/wonkblog/wp/2013/05/09/chinas-crackdown-on-trash-could-make-it-harder-for-u-s-cities-to-recycle/> Accessed on: 10 May 2013
43. Resource Recycling, (2013). Operation Green Fence is deeply affecting export markets. See: <http://resource-recycling.com/node/3679> Accessed on: 15 June 2014
44. Messenger, B. (2013). Recycled plastics market set to triple, but China's 'green fence' hampering exports. See: <http://www.waste-management-world.com/articles/2013/06/new-sita-recycling-plant-in-birmingham-producing-srf--rdf.html> Accessed on: 20 July 2013
45. Ford, P. (2013). China puts up a green wall to US trash. See: <http://www.csmonitor.com/World/Asia-Pacific/2013/0619/China-puts-up-a-green-wall-to-US-trash> Accessed on: 20 June 2013
46. Complydirect (2013). Demand for recycled plastics to triple by 2020. See: <http://www.complydirect.com/latest/news/?id=255> Accessed on: 15 June 2013
47. Goldstein, S. (2008). Waste trade imperils UK reprocessing goals. *Packaging News*, (APR.), 41.
48. Guilford, G. (2013). China doesn't want your trash anymore - and that could spell big trouble for American cities. See: <http://qz.com/82640/china-doesnt-want-your-trash-anymore-and-that-could-spell-big-trouble-for-american-cities/> Accessed on: 10 June 2014
49. Smulian, M. (2013). Industry welcomes tougher rules on exports. See: <http://www.mrw.co.uk/news/industry-welcomes-tougher-rules-on-exports/8647827.article> Accessed on: 14 May 2013
50. British Plastics Federation (BPF), (2013). *Business conditions survey for the UK plastics industry*; British Plastics Federation: London, UK, January 2013, p8. See: <http://www.google.co.uk/url?sa=t&rct=j&q=&esrc=s&frm=1&source=web&cd=2&ved=0CDcQFjAB&url=http%3A%2F%2Fwww.bpf.co.uk%2FDocument%2FDefault.aspx%3FDocumentUId%3D4f2786d7-5b4f-4413-9188-70c971487e77&ei=LvkUZ2CPMblQOX6wYHQBg&usq=AFQjCNUF5gxLUXVG8iwTknQFNfNoA4CQJg&sig2=ujgYuSXD5bmfCltH38u-Mg> Accessed on: 10 June 2014
51. Closed Loop Recycling, (2012). Welcome to Closed Loop Recycling. See: <http://www.closedlooprecycling.co.uk/> Accessed on: 15 May 2013
52. Kamuk, B.; Hansen, A. J. (2007). Global recycling – waste trafficking in disguise? *Waste Management & Research* 25, (6), 487-488.
53. Bilitewski, B. (2012). The Circular Economy and its Risks. *Waste Manage.* 32, (1), 1-2.
54. Velis, C. A.; Brunner, P. H. (2013). Recycling and resource efficiency: It is time for a change from quantity to quality. *Waste Management & Research* 31, (6), 539-540.
55. Wang, J. (2013). The top ten issues facing China's plastics recycling industry. *Plast. Eng.* 69, (8), 42-49.
56. Albrecht, N.; Wang, J. (2014). Die-Doku: Tödlicher Müll in China [in German: "Deadly waste in China"]. See: <http://www.zdf.de/ZDFmediathek#/beitrag/video/1993090/Die-Doku:-Tödlicher-Müll-in-China> Accessed on: 20 May 2014
57. Halden, R. U. (2010). Plastics and health risks. In Vol. 31, pp 179-194.
58. Clausen, P. A.; Liu, Z.; Kofoed-Sørensen, V.; Little, J.; Wolkoff, P. (2012). Influence of temperature on the emission of Di-(2-ethylhexyl)phthalate (DEHP) from PVC flooring in the emission cell FLEC. *Environ. Sci. Technol.* 46, (2), 909-915.
59. Zeng, L. S.; Zhou, Z. F.; Shi, Y. X. (2013). Effects of phthalic acid esters on the ecological environment and human health. In Guangzhou, Vol. 295-298, pp 640-643.

60. Huang, Y. Q.; Wong, C. K. C.; Zheng, J. S.; Bouwman, H.; Barra, R.; Wahlström, B.; Neretin, L.; Wong, M. H. (2012). Bisphenol A (BPA) in China: A review of sources, environmental levels, and potential human health impacts. *Environment International* 42, (1), 91-99.
61. Zeng, N.; Yao, J.; Tang, Z. W.; Huang, Q. F.; Jin, L.; He, J. (2013). Pollution characteristics of polybrominated diphenyl ethers in soils from waste plastic recycling region in China. *Research of Environmental Sciences* 26, (4), 432-438.
62. Deng, C.; Li, Y.; Li, J. H.; Li, H. F. (2014). A mini-review on disposal of WEEE plastics containing PBDES with a special focus on china. In Vol. 878, pp 600-608.
63. Rustagi, N.; Pradhan, S. K.; Singh, R., 2011, Public health impact of plastics: An overview. *Indian Journal of Occupational and Environmental Medicine* 15, (3), 100-103.
64. Peeters, J. R.; Vanegas, P.; Tange, L.; Van Houwelingen, J.; Duflou, J. R. (2014). Closed loop recycling of plastics containing Flame Retardants. *Resources, Conservation and Recycling* 84, 35-43.
65. Yamashita, K.; Yamamoto, N.; Mizukoshi, A.; Noguchi, M.; Ni, Y.; Yanagisawa, Y. (2009). Compositions of volatile organic compounds emitted from melted virgin and waste plastic pellets. *J. Air Waste Manage. Assoc.* 59, (3), 273-278.
66. Townsend, D. (2007). Plastic problems. *Fire Prevention and Fire Engineers Journals*, (APR.).
67. Derudi, M.; Nano, G.; Gelosa, S.; Slipevich, A.; Santantonio, P.; Perfetto, A.; Rot, R. (2012). In *Emissions of hazardous compounds during PVC manufacturing processes*, Helsinki, 2012; Helsinki, pp 1313-1319.
68. Helal, S. F.; Elshafy, W. S. (2013). Health hazards among workers in plastic industry. *Toxicology and Industrial Health* 29, (9), 812-819.
69. Appelquist, B. (2011). *ISWA Position Paper on Waste Trafficking*, ISWA
70. D'Amato, A.; Iozzi, A.; Trovato, G. (2012). The trade of polyethylene waste: Prices or policies? *Environmental Economics and Policy Studies* 14, (4), 341-356.
71. Rajendran, S.; Hodzic, A.; Scelsi, L.; Hayes, S.; Soutis, C.; AlMa'adeed, M.; Kahraman, R. (2013). Plastics recycling: Insights into life cycle impact assessment methods. *Plastics, Rubber and Composites* 42, (1), 1-10.
72. Lazarevic, D.; Aoustin, E.; Buclet, N.; Brandt, N. (2010). Plastic waste management in the context of a European recycling society: Comparing results and uncertainties in a life cycle perspective. *Resources, Conservation and Recycling* 55, (2), 246-259.
73. Astrup, T.; Fruergaard, T.; Christensen, T. H. (2009). Recycling of plastic: Accounting of greenhouse gases and global warming contributions. *Waste Manage. Res.* 27, (8), 763-772.
74. Weber, A. (2013). Toy assembly isn't child's play. *Assembly* 56, (12).
75. Tolinski, M. (2011). *Plastics and Sustainability: Towards a peaceful coexistence between bio-based and fossil fuel-based plastics*. John Wiley & Sons.
76. Philp, J. C.; Bartsev, A.; Ritchie, R. J.; Baucher, M. A.; Guy, K. (2013). Bioplastics science from a policy vantage point. *New Biotechnology* 30, (6), 635-646.
77. Soroudi, A.; Jakubowicz, I. (2013). Recycling of bioplastics, their blends and biocomposites: A review. *Eur. Polym. J.* 49, (10), 2839-2858.
78. Cornell, D. D. (2007). Biopolymers in the existing postconsumer plastics recycling stream. *J. Polym. Environ.* 15, (4), 295-299.
79. Xanthos, M. (2012). Recycling of the #5 Polymer. *Science* 337, (6095), 700-702.



ISWA

International Solid Waste Association

The International Solid Waste Association (ISWA) is a global, independent and non-profit making association, working in the public interest to promote and develop sustainable waste management. ISWA has members in more than 60 countries and is the only worldwide association promoting sustainable, comprehensive and professional waste management.

ISWA's objective is the worldwide exchange of information and experience on all aspects of waste management. The association promotes the adoption of acceptable systems of professional waste management through technological development and improvement of practices for the protection of human life, health and the environment as well as the conservation of materials and energy resources.

ISWA's vision is an Earth where no waste exists. Waste should be reused and reduced to a minimum, then collected, recycled and treated properly. Residual matter should be disposed of in a safely engineered way, ensuring a clean and healthy environment. All people on Earth should have the right to enjoy an environment with clean air, earth, seas and soils. To be able to achieve this, we need to work together.

For information about ISWA, visit our homepage at www.iswa.org

Members of the ISWA TASK Force on Globalisation and Waste Management

Antonis Mavropoulos

Chair
D-Waste, Greece

David C Wilson

Scientific Co-ordinator
Imperial College London, UK

Björn Appelqvist

Editor
City of Copenhagen, Denmark

Costas Velis

University of Leeds, UK

Jeff Cooper

Independent Consultant, UK



International Solid Waste Association

Auerspergstrasse 15, Top 41
1080 Vienna
Austria

Telephone: +43 (1) 253 6001

Telefax: +43 (1) 253 6001 99

Email: iswa@iswa.org

